

Model

FCP-50 FALSE CEILING PLATE KIT

Thank you for purchasing this **PDR** product

To ensure the correct usage, please read and follow the instruction manual thoroughly. Please store the instructions in a safe place for future reference.

All **PDR** mounts and adapters carry a limited **lifetime warranty** against defects in material and workmanship.

We are not liable for improper installation that results in damage to mounts, adapters or presentation equipment.

Special techniques are necessary for installation of the panel display mount.

- Do not attempt to perform this work by yourself.
- Request an installation specialist to install this unit.
- Manufacturer assumes absolutely no responsibility for injuries and damages that may occur due to improper installation and handling.

To ensure customer safety, be sure to decide the installation location so that the strength is sufficient to withstand the weight of both the projector and the false ceiling plate kit .(FCP)

Always use at least two persons for all installations.

Fully tighten all of the mounting screws as specified in the installation instructions.

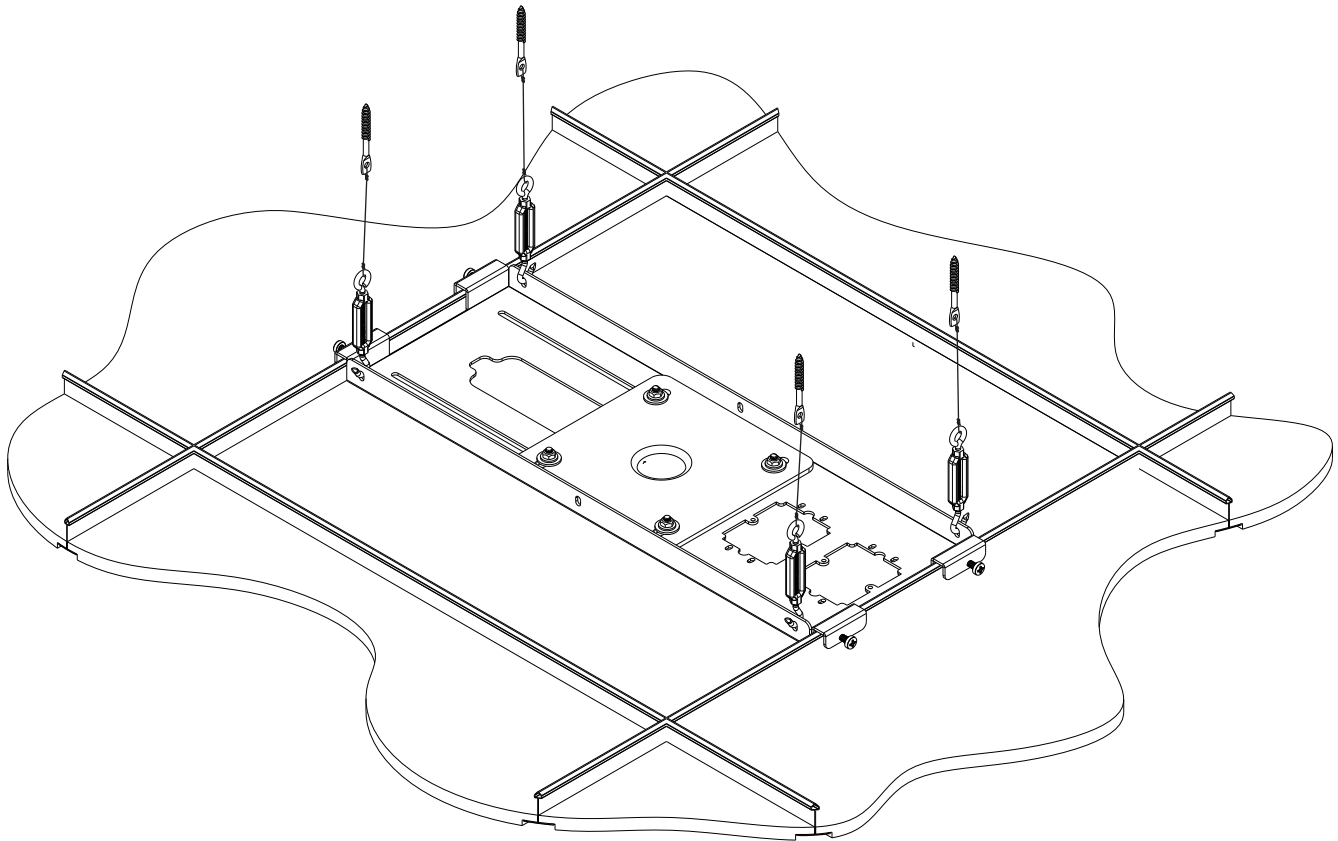

Suitable for mounting above 2' x 2' or 2' x 4' ceiling tiles

WARNINGS AND PRECAUTIONS

WARNING

-  The ceiling structure must be capable of supporting at least 5 times the weight of the projector and the FCP kit. Check with a qualified installer to verify the ceiling's integrity to support the projector and FCP kit per instructions. Failure to do so could cause serious injury.

Note: Incorrect installation can cause the projector to fall and cause injury.

**Total load of the projector + FCP-50 DROPCEILKIT
MAXIMUM WEIGHT - 60 Lbs. (27 Kg.)**

INSTALLATION ON A FALSE CEILING

Always install so that the load is carried by the ceiling support structure (not the false ceiling) thru the guide wires and turn buckles supplied. The ceiling structure must be able to support at least 5 times the weight of the projector and the FCP kit.

CAUTION

- Avoid installing in locations where the temperature and humidity are excessively high, and where contact with any water is possible. These can result in fire or electric shock.
- Do not install close to an air conditioner intake or outlet. Do not install in locations where there are excessive amounts of dust, oily smoke or tobacco smoke. Fire could result.
- Do not block the ventilation holes. Leave sufficient clearance in regard to the surroundings to avoid blocking the ventilation. The internal temperature could elevate and possibly result in fire. Install the projector (4") or more away from surroundings.
- Do not install in locations where there is excessive vibration or impact. Injury and damage could result from the panel display falling.
- Do not install where there is direct sunlight or other strong light. Strong light could result in eye fatigue during usage.

WARNING

- Use the specified bolts and screws in the specified places and tighten firmly. Failure to do this could cause injury if the projector falls.
- Do not alter any of the parts. Do not use broken parts. This could result with injury due to the projector falling.
- Always use at least two people to perform the installation work. Injury could result from dropping heavy objects.

***Caution:* installation of the unit is to be carried out by qualified technicians only. Install in an appropriate location by checking the ceiling structure and durability for safety and accident prevention**



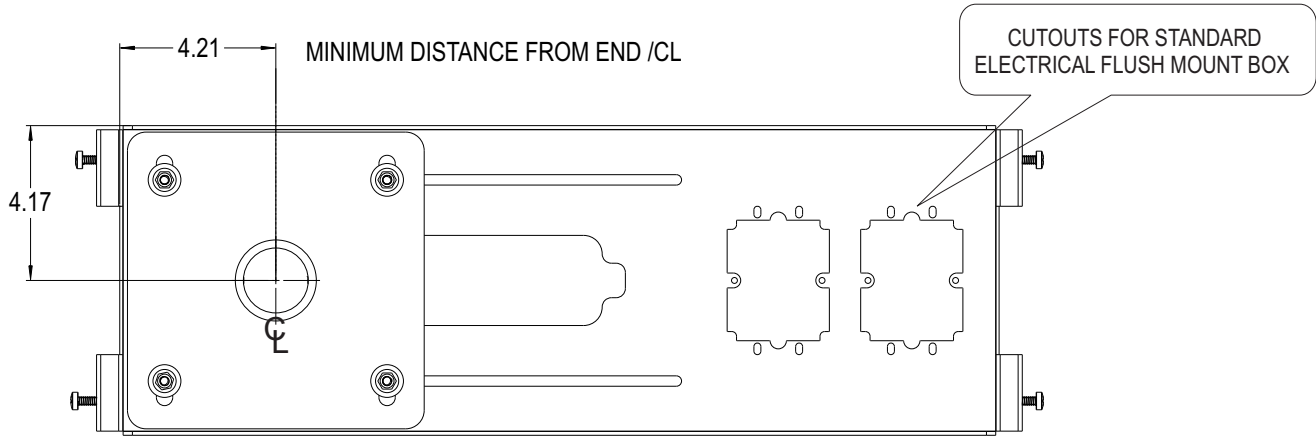
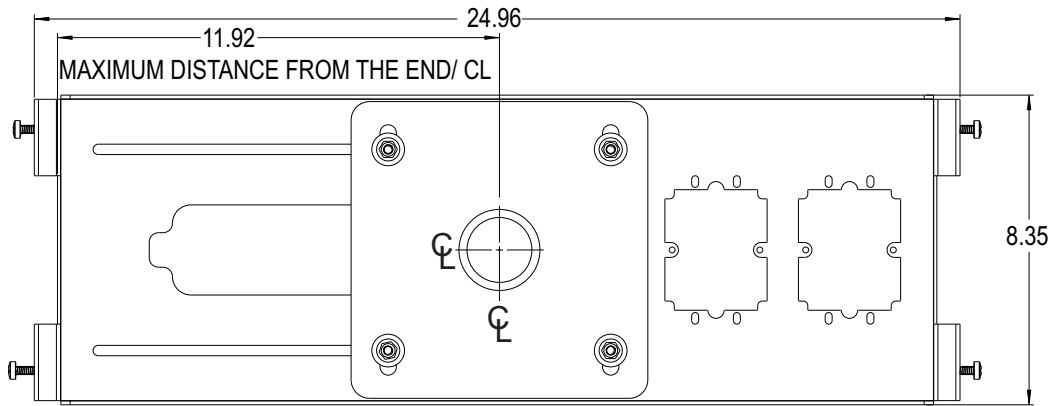

SPECIFICATIONS

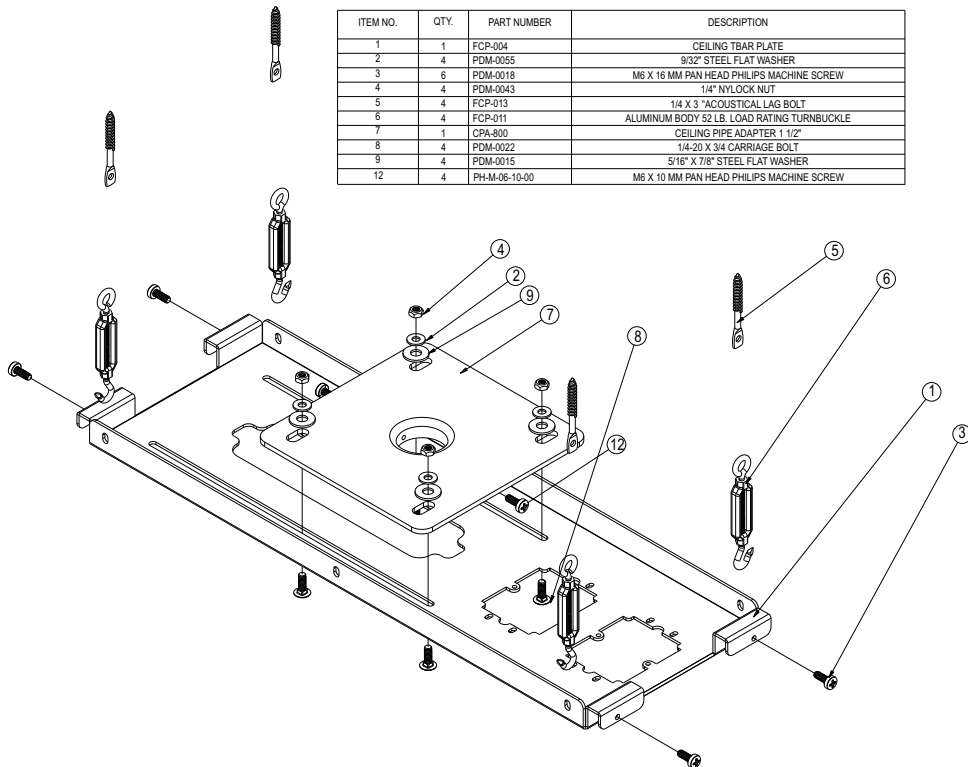

ITEM NO.	QTY.	PART NUMBER	DESCRIPTION
1	1	FCP-004	CEILING TBAR PLATE
2	4	PDM-0055	9/32" STEEL FLAT WASHER
3	6	PDM-0018	M6 X 16 MM PAN HEAD PHILIPS MACHINE SCREW
4	4	PDM-0043	1/4" NYLOCK NUT
5	4	FCP-013	1/4 X 3 "ACOUSTICAL LAG BOLT
6	4	FCP-011	ALUMINUM BODY 52 LB. LOAD RATING TURNBUCKLE
7	1	CPA-800	CEILING PIPE ADAPTER 1 1/2"
8	4	PDM-0022	1/4-20 X 3/4 CARRIAGE BOLT
9	4	PDM-0015	5/16" X 7/8" STEEL FLAT WASHER
12	4	PH-M-06-10-00	M6 X 10 MM PAN HEAD PHILIPS MACHINE SCREW

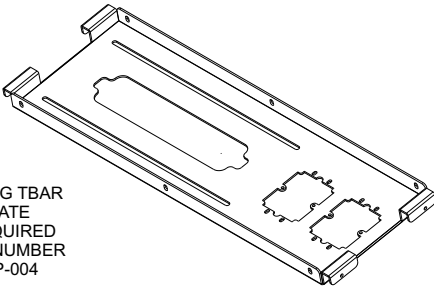
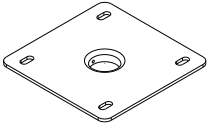
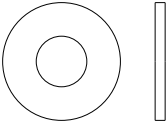
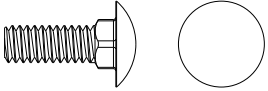
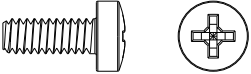
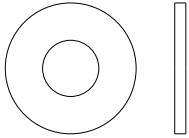

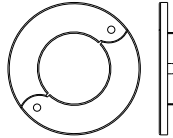
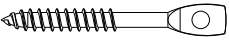
HARDWARE

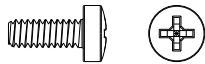
<p>1</p>  <p>CEILING TBAR PLATE 1 REQUIRED PART NUMBER FCP-004</p>	<p>7</p>  <p>CEILING PIPE ADAPTER 1 1/2" 1 REQUIRED PART NUMBER CPA-800</p>
<p>2</p>  <p>9/32 ID X 5/8 OD STEEL FLAT WASHER 4 REQUIRED PART NUMBER FW-E-28-62-00</p>	<p>8</p>  <p>1/4-20 X 3/4 CARRIAGE BOLT 4 REQUIRED PART NUMBER CB-E-25-75-00</p>
<p>3</p>  <p>M6 X 16 PAN HEAD PHILLIPS MACHINE SCREW 5 REQUIRED PART NUMBER PH-M-06-16-00</p>	<p>9</p>  <p>5/16 ID X 7/8 OD STEEL FLAT WASHER 4 REQUIRED PART NUMBER FW-E-31-87-00</p>
<p>4</p>  <p>1/4-20 NYLOCK NUT 4 REQUIRED PART NUMBER NU-E-25-18-00</p>	<p>10</p>  <p>1.50" CHROME TRIM RING 1 REQUIRED PART NUMBER FCP-016</p>
<p>5</p>  <p>1/4 X 3 FLATTENED END HANGER BOLTS 4 REQUIRED PART NUMBER SH-E-25-30-00</p>	<p>11</p>  <p>14 GAGE SOFT GALVANIZED WIRE 60 FOOT ROLL 1 REQUIRED PART NUMBER FCP-014</p>
<p>6</p>  <p>HOOK END AND EYE END TURNBUCKLE 4 REQUIRED PART NUMBER TB-E-21-45-00</p>	<p>12</p>  <p>M6 X 10 PAN HEAD PHILLIPS MACHINE SCREW 1 REQUIRED PART NUMBER PH-M-06-16-00</p>

ASSEMBLY AND INSTALLATION INSTRUCTIONS

1. Install the #3 M6 screws into the ends of the #1 FCP-001 ceiling t-bar plate . Leave enough room to slide over the ceiling grid bars. **See fig 1**
2. Install the #7 CPA-800 1 ½" ceiling pipe adapter onto the #1 FCP-004 plate using the hardware #2,3,4,8 and 9. Do not tighten at this time. **See fig 2.**
3. Determine where the 1 ½" pipe will be located in the ceiling. The FCP center point can be located anywhere within 4 1/4" from any outer edge of the tile **See fig 3** . Place a mark on the location and drill a small hole through the ceiling tile.
4. Remove the tile adjacent to the tile where the pipe mount will be installed (for easy access).
5. Place the FCP ceiling kit into the grid and adjust the mount to the center of the pilot hole drilled into the tile. **See fig 3.**
6. Using a pencil trace the inside of the CPA-800 onto the ceiling tile.
7. Remove the FCP and the ceiling tile
8. Using a knife, saw blade or hole saw cutout the area marked by a pencil. Include enough clearance for the pipe and lock screw #3.
9. Replace the ceiling tile and the FCP mount into the ceiling grid. Check the alignment of the clearance hole for the pipe and the hardware on the CPA-800. Leave the M6 screws on the ends to the t-bar loose at this time.

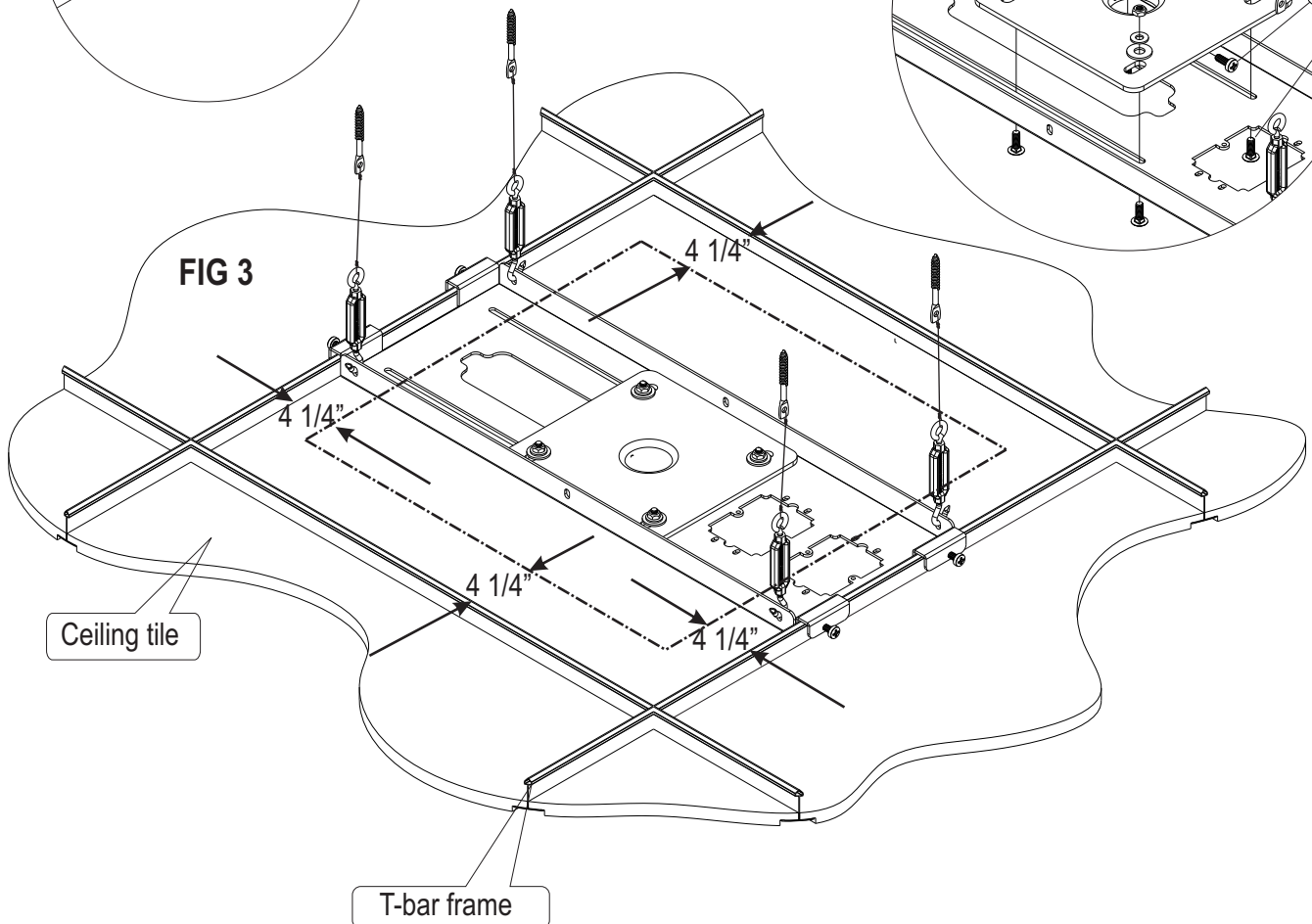
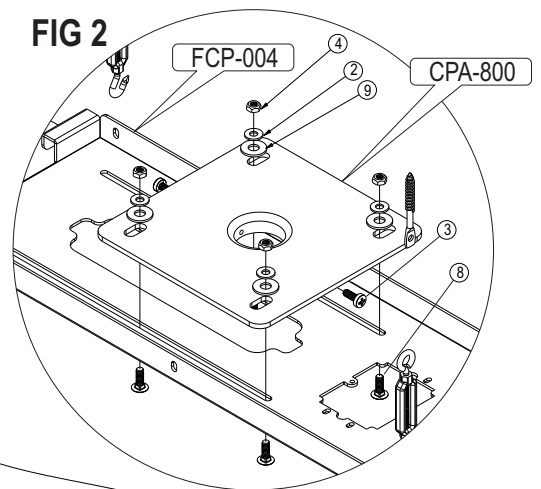
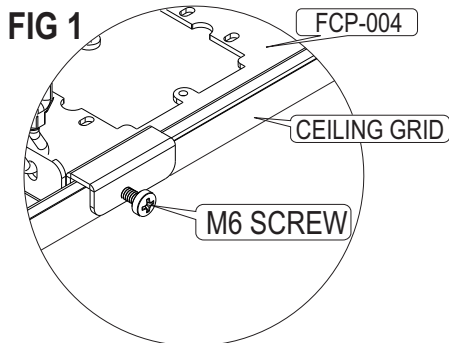

CEILING SUPPORT INSTRUCTIONS

1. These instructions are intended for use in a wooden sub structure. Alternate substructure such as concrete or steel capable of supporting 5 x the weight of the mount and display system can also be used (fasteners not supplied for other than wood sub structure)
 2. Locate the hardware to secure the FCP kit. Part #5,6,11. **See page 4**
 3. Locate and mark the anchor points for the end hanger bolts #5 . Space the bolts centered above the mount at least 6" wider on all sides than the FCP mount **See fig 4 & 6**
 4. Drill a 3/16" pilot hole into the wood substructure and screw the hanger bolts until no threads are exposed about 1 1/2" deep.
 5. Place the turnbuckle into the holes on the FCP plate and extend the turnbuckles 50% of full travel **See fig 4 & 5**
 6. Measure the distance from the hanger bolts #5 to the end of the turnbuckles # 6.
 7. Cut the 14ga wire supplied (#11) about 12" longer than the measurement taken in step 6.
 8. Pass the wire thru the #5 hanger bolts about 6", and coil the end around the wire about 5 x with the last strand looped thru the last coil . This will aid in the support system. **See fig 4**
 9. Straighten the wire and attach to the eye end of the turnbuckle. Coil in the same manner in step 8.
 10. Apply a small hand pressure on the FCP plate downward and fine adjust the turn buckle to take up the slack in the 14ga wire, a final adjustment will be needed with the 1 1/2" pipe and projector installed.
- NOTE: The FCP is supported by the 14ga guide wires not the false ceiling structure or t-bars .**

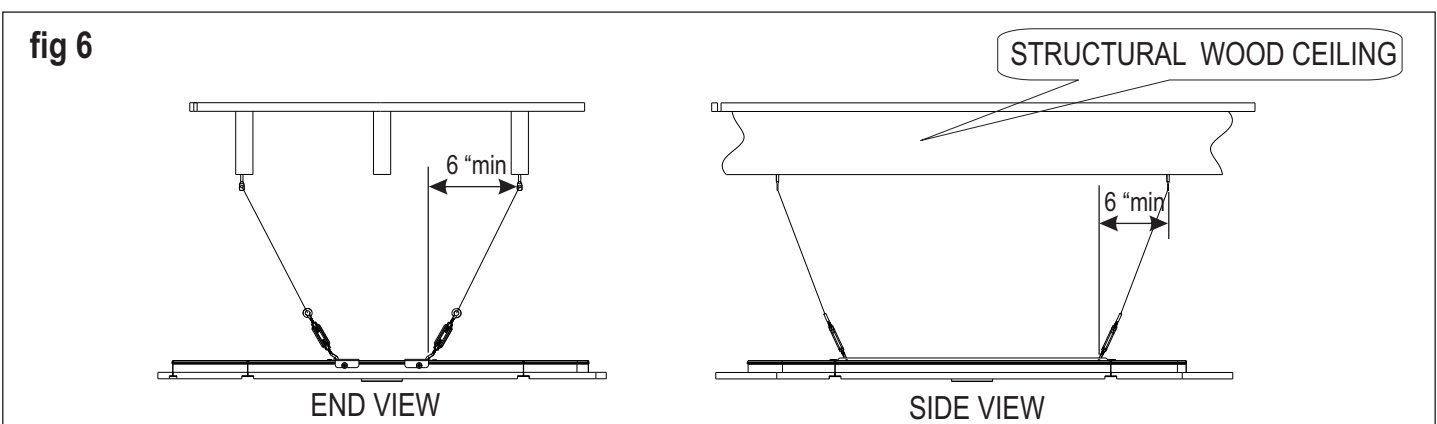
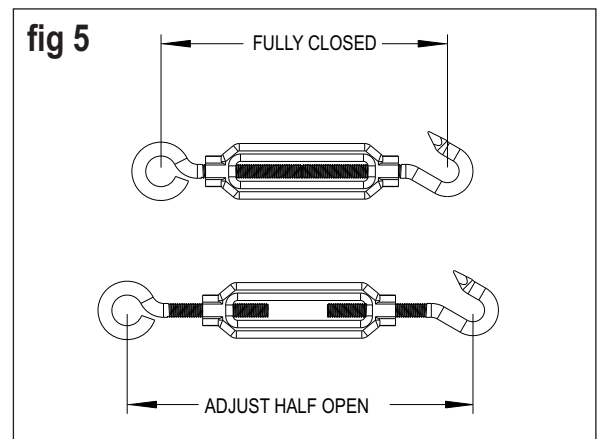
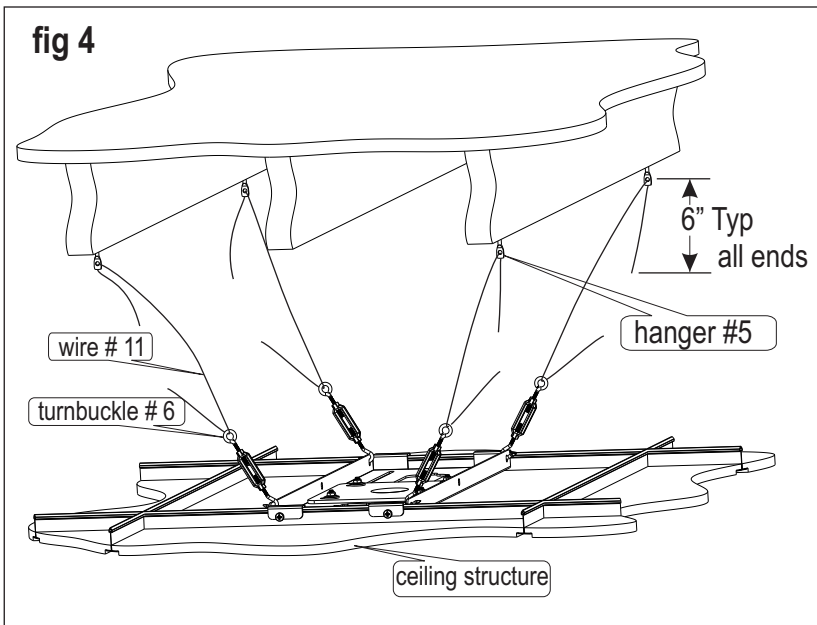

ELECTRICAL BOX AND LOCKING SCREW INSTRUCTIONS

1. This operation should only be carried out by a Qualified electrician, following local codes and regulations. Be sure to disconnect the power source before connections are made.
2. Cut the electrical outlets thru the ceiling tiles (optional). Allow for the screw holes for the box on the bottom side. **See fig 8**
3. Attach the electrical box (not supplied) . **See fig 8**
4. Run wiring and make connections per local codes and regulations .
5. Install the 1 ½" pipe (not supplied) into the FCP mount. **See fig 9**
6. Lift the FCP with the 1 ½" pipe attached to tighten the #3 M6 x 16mm screw . Lower the unit back over the ceiling grid bars and tighten the four # 3 screws **See fig 8**
7. Install the chrome trim ring #10 onto the 1 ½" pipe . Clip the ends together and slide up to the ceiling tile. **See fig 9**
9. **NOTE be sure to adjust the turnbuckles after the projector is mounted onto the 1 ½" pipe drop. Failure to do so may cause the ceiling to buckle.**

