

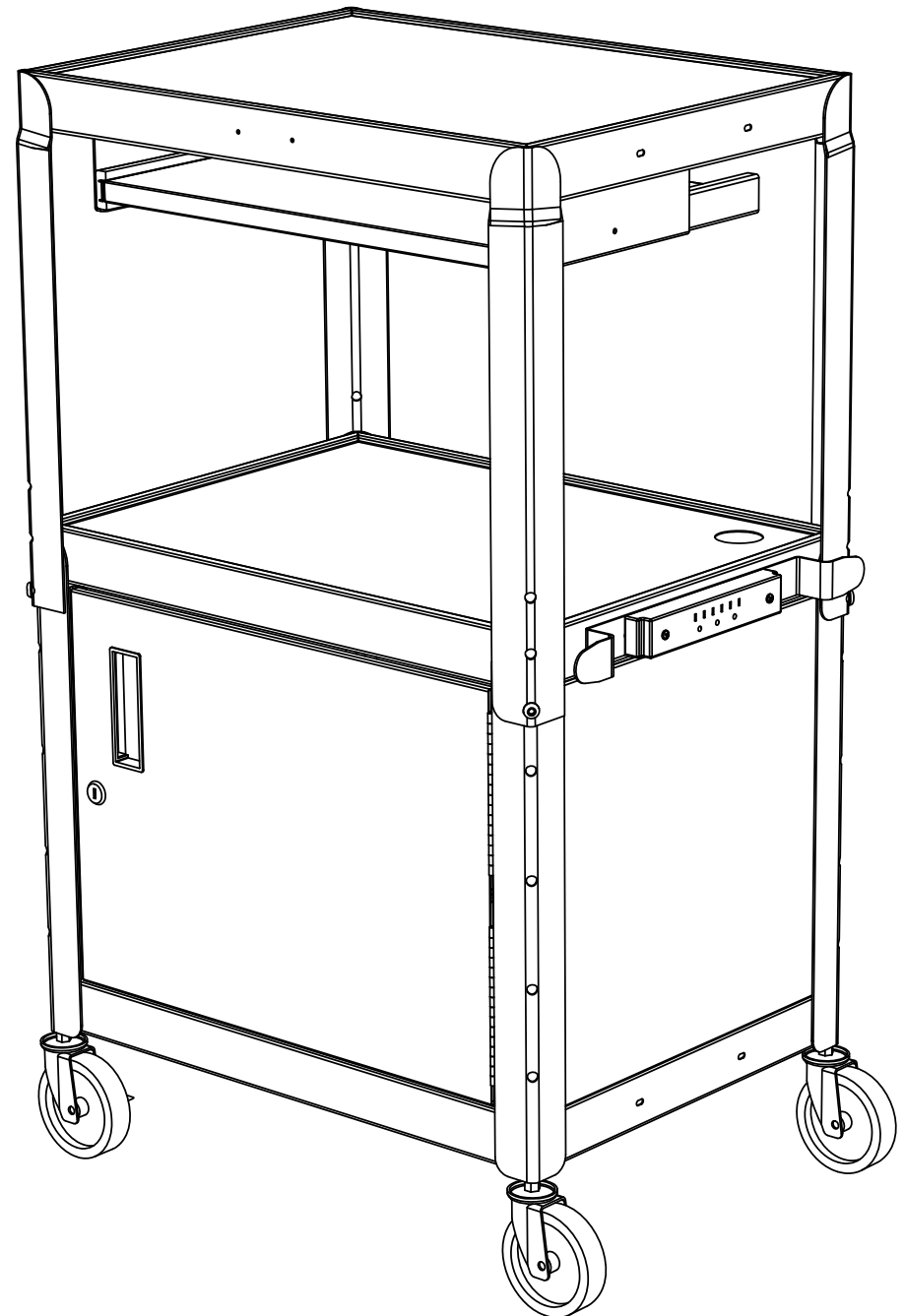

AV CART

SS-AVJ42KBC



LINE LEADER

Contact Us:

www.standsteady.com

customerservice@standsteady.com

1-703-688-DESK (3375)

Made in Taiwan

PRODUCT OVERVIEW

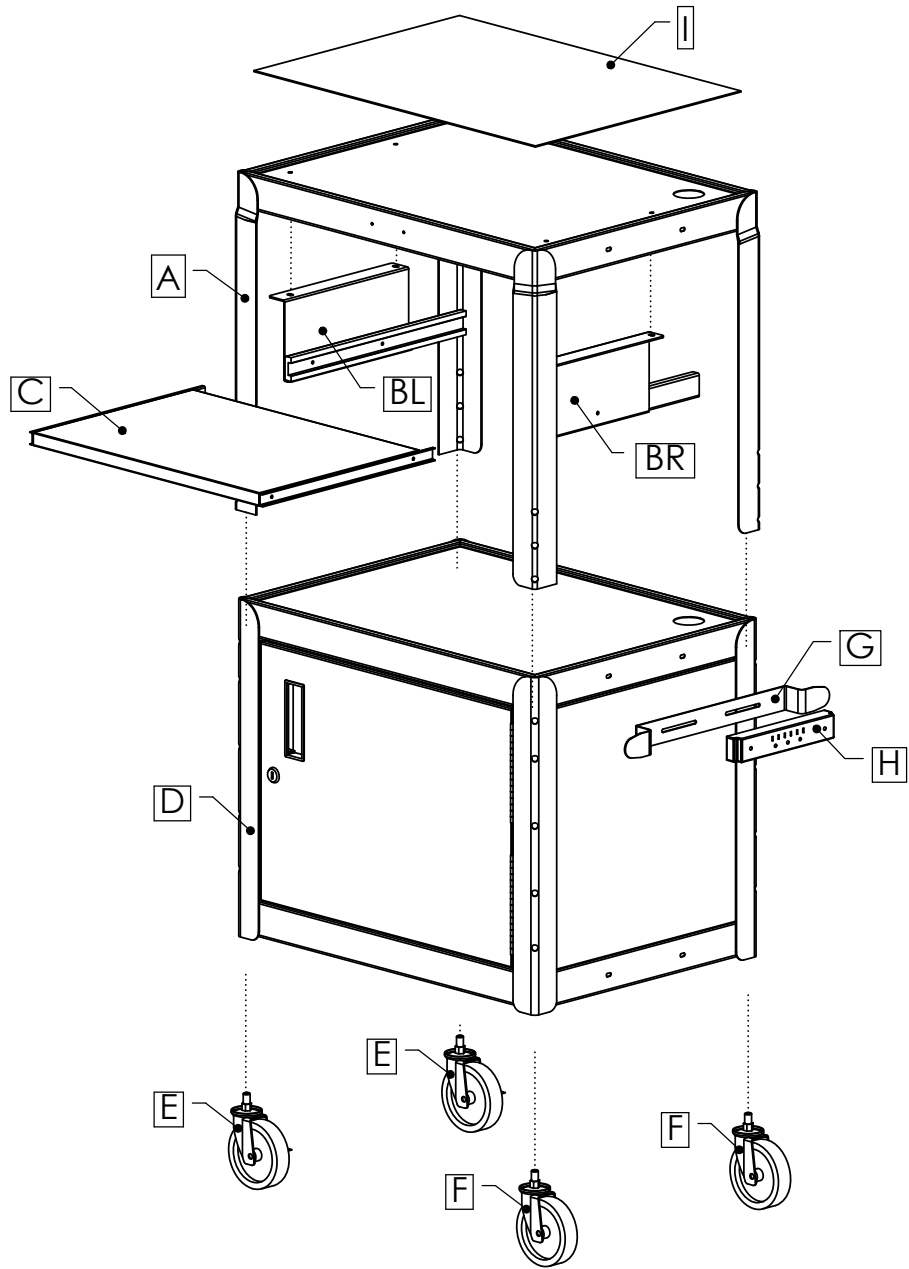

CART COMPONENTS

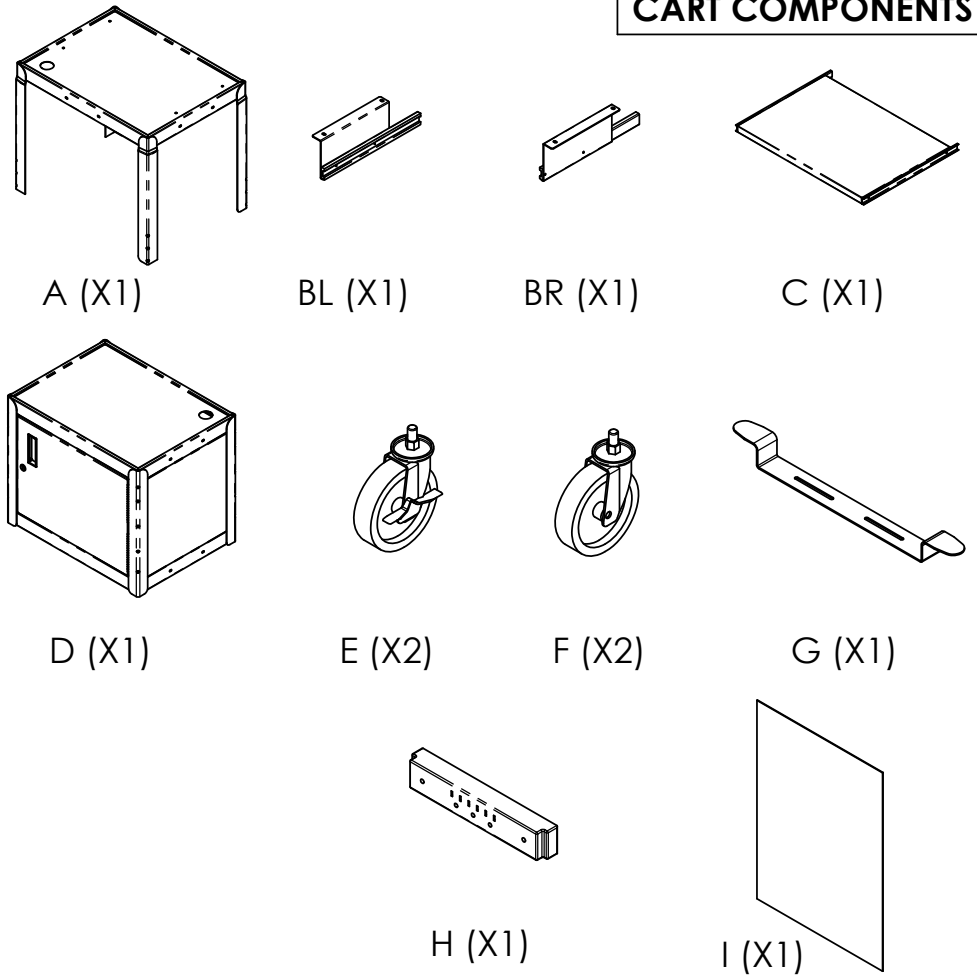

HARDWARE

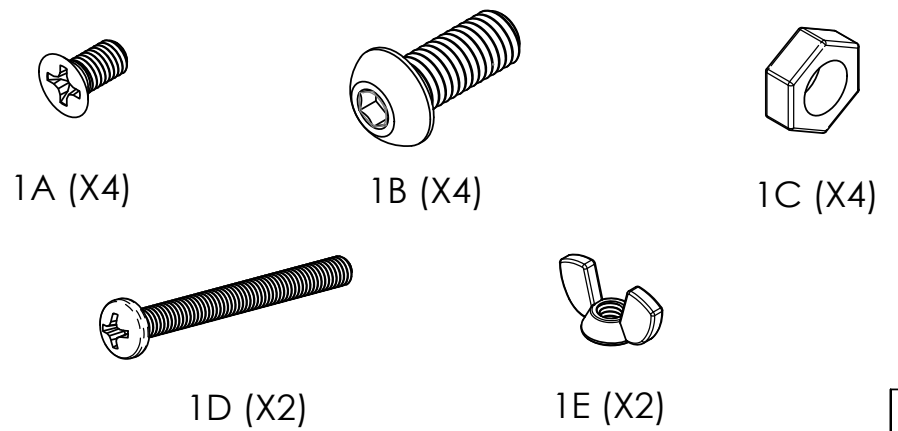

STEP 1: ATTACH KEYBOARD TRAY BRACKETS

Attach keyboard brackets (BL & BR) to upper cart assembly (A) using 1A (x4).

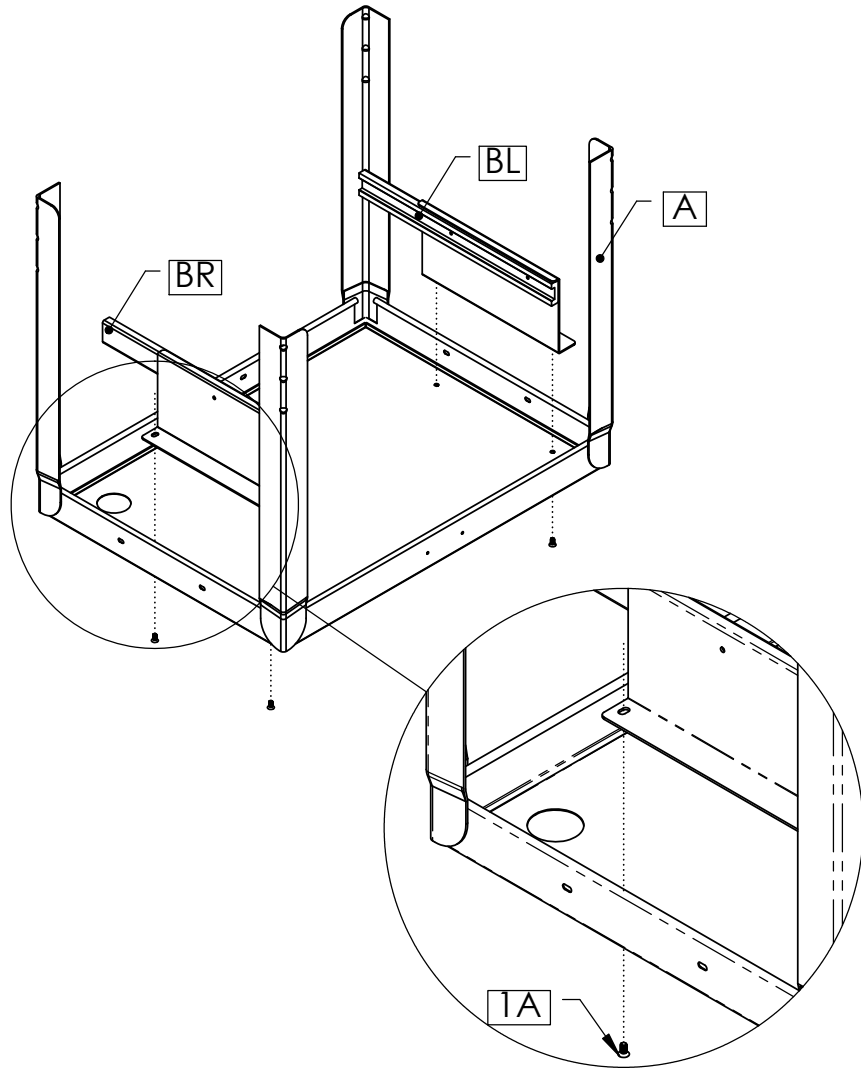

REQUIRED HARDWARE



1A
QTY. 4

STEP 2: SLIDE KEYBOARD TRAY INTO BRACKETS

Slide Keyboard Tray (C) into Brackets

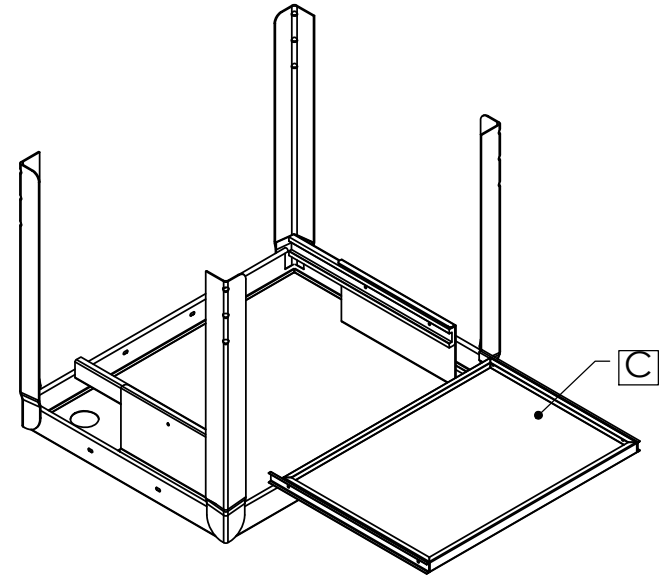

STEP 3: ATTACH CASTERS

Flip lower cart assembly (D) upside down.
Install Casters (E/F) using rubber mallet

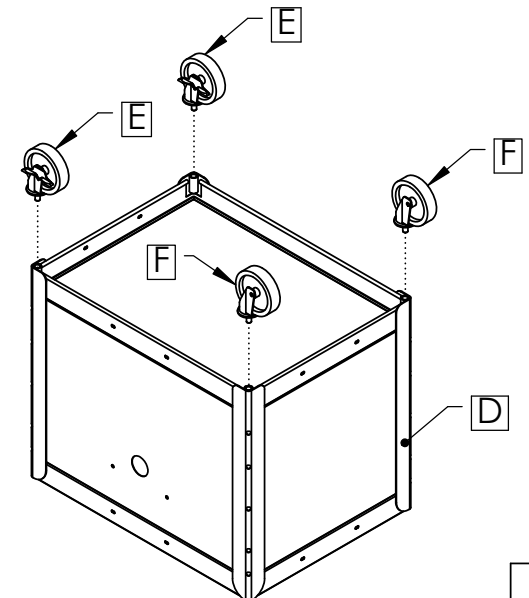

STEP 4: ALIGN CART COMPONENTS

Rest parts A&D on their side. Slide together until the holes on the legs are aligned at the desired height.

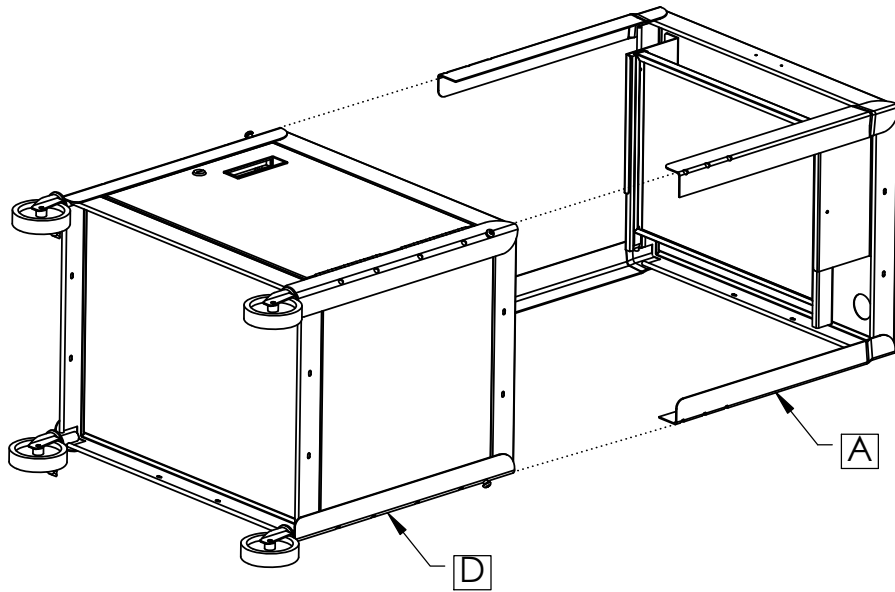

STEP 5: SECURE CART COMPONENTS

Secure parts A&D using 1B & 1C (x4)

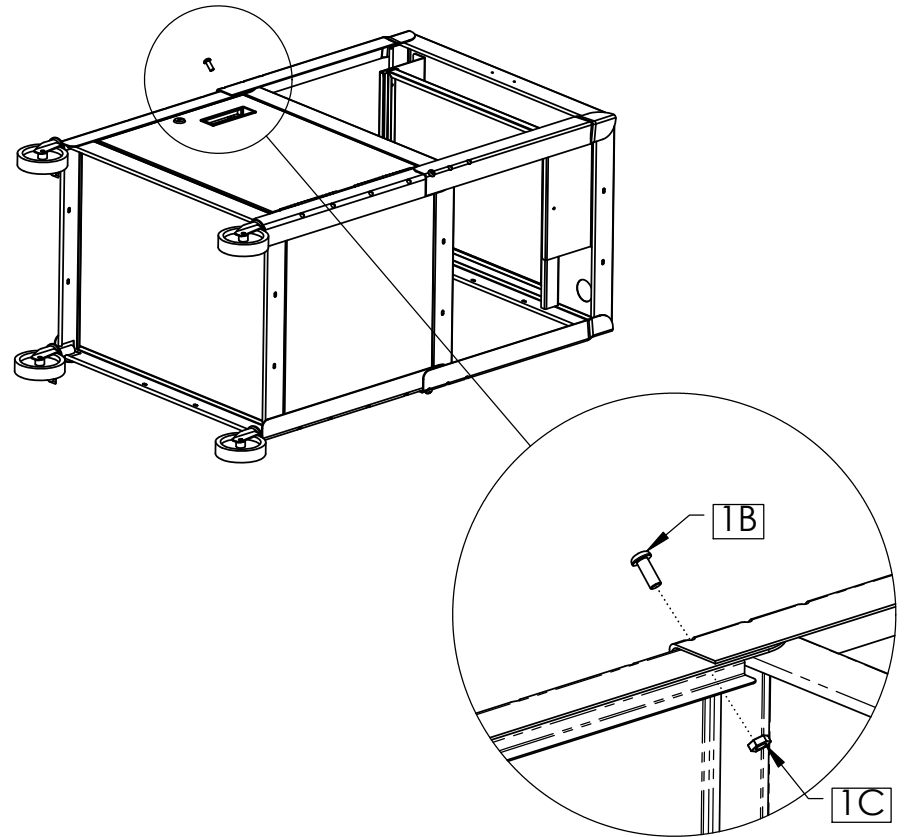

Note: Open door to secure 1C (x4)

REQUIRED HARDWARE

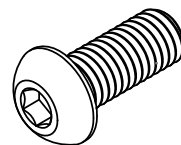

1B
QTY. 4

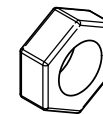

1C
QTY. 4

REQUIRED TOOLS



STEP 6: CHOOSE LOCATION

Power Strip can be installed in multiple places on the cart.

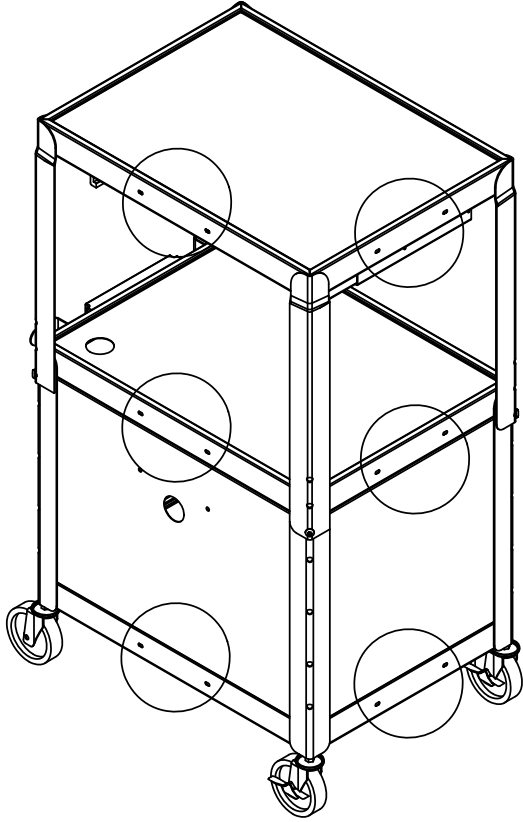

STEP 7: ATTACH POWER STRIP

Stand up Cart. Secure parts G&H in desired location using 1D & 1E (x2)

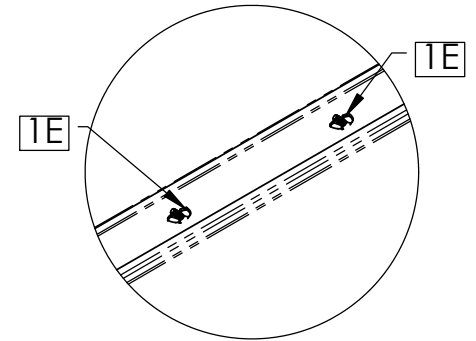
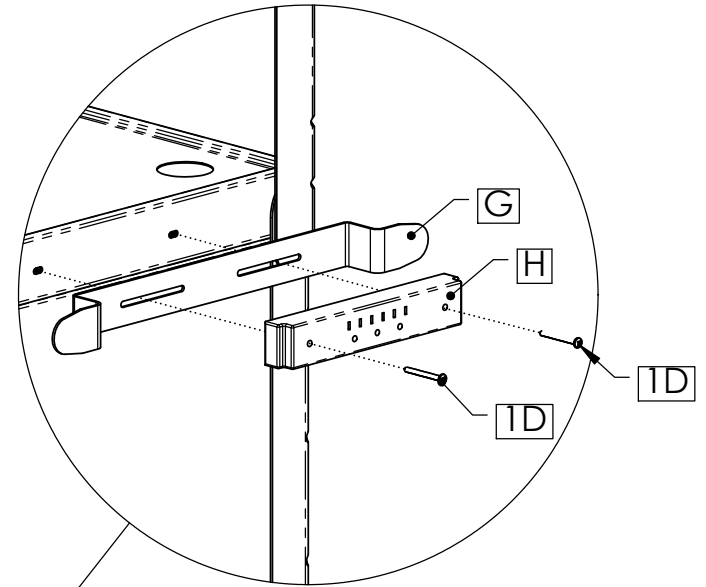
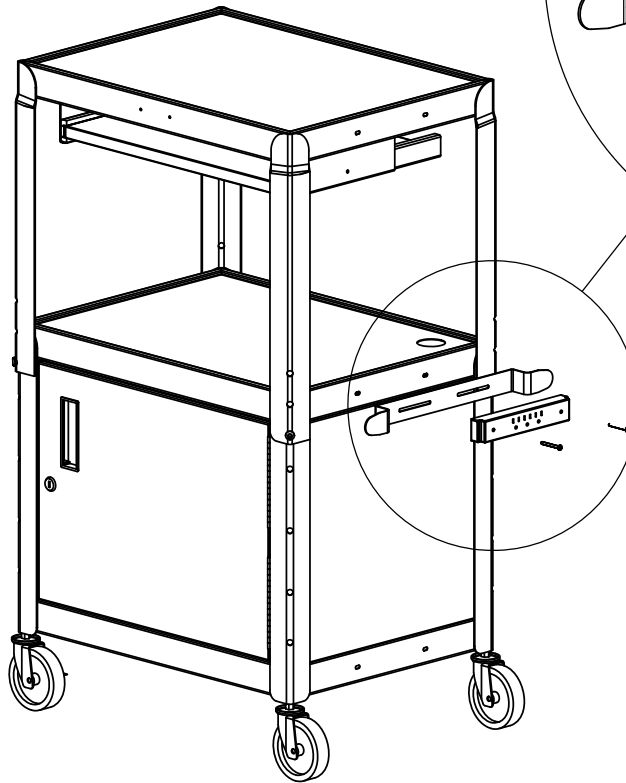

*NOTE: Secure bracket/power strip from inside cabinet using 1F (x2)

REQUIRED HARDWARE

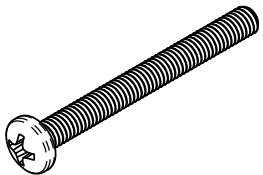

1D
QTY. 2



1E
QTY. 2