

Tools Required:

Rubber Mallet



Hardware Required:

None



- 1**
- Press casters (E) into bottom side of lower shelf (A) as shown.
 - Press locking casters (D) into bottom side of lower shelf (A) as shown.
 - Use rubber mallet as needed until fully inserted.

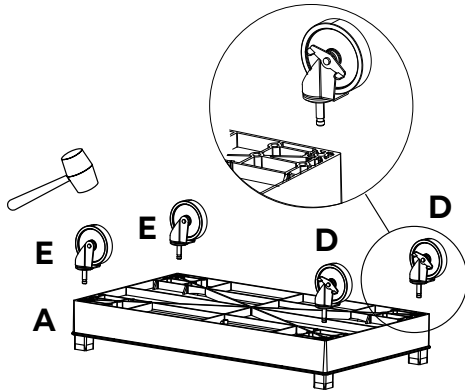

- 2**
- Press the vertical posts (F) into the top shelf (C)
 - Press middle shelf (B) into the top of the vertical posts (F)
 - Use rubber mallet as needed until full inserted.

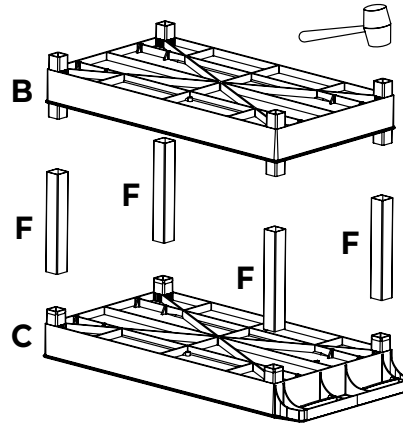

- 3**
- Press vertical posts (F) into middle shelf (B).
 - Apply 2nd middle shelf (B) to the top of the vertical posts.
 - Use the rubber mallet as needed until fully inserted.

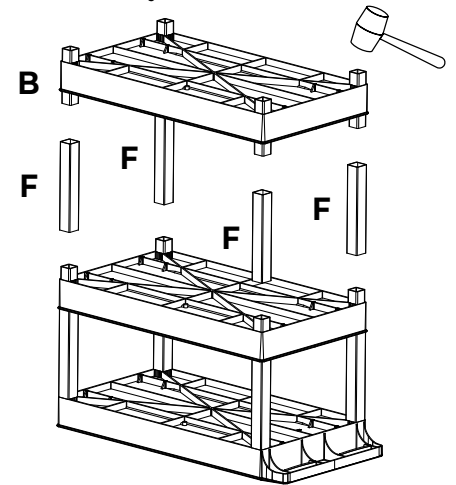

- 4**
- Press vertical posts (F) into second middle shelf (B).
 - Apply lower shelf (A) to the top of the vertical posts.
 - Locking casters should be aligned with the handle side of the top shelf.
 - Use the rubber mallet as needed until fully inserted.

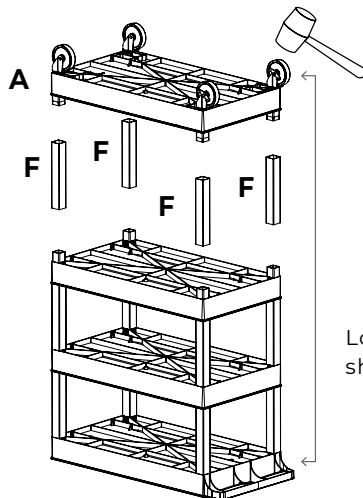

Locking casters should be aligned.

Finished Product

- Carefully turn product onto casters.
- Lock casters when product is stationary.

