

BALE BAND-IT

Operator's Manual

Model 100



PIKE 
Mfg. Corp.

P.O. Box 492
Alpena, MI 49707
(217) 285-6487
www.balebandit.com
sales@balebandit.com

Version 1.11

Safety Warning





-  Read the entire manual prior to operating or performing maintenance on your machinery.
-  Do not operate machinery in any manner other than which it was designed.
-  Do not operate machinery without taking proper safety precautions and only while all safety devices and measures are in place, set correctly, and in working condition.
-  Do not operate machinery if safety devices are not properly working. This can cause serious injury or death.
-  Maintenance should be performed by qualified personnel only and they need to ensure that power and hydraulics have been disconnected and all stored energy has been released prior to performing any maintenance.

Table of Contents

Specifications	1
Warranty and Service	2
Serial Number Location	3
Safety	4
Hooking Up.....	9
Bale Band-It Threading Instructions.....	11
Concepts of Operation.....	16
Sequence of Events.....	16
Manual Overrides	17
Manual Bundle Removal.....	17
Strapping Count.....	17
Reset Strapping Button	17
Reset Bundle Button.....	18
Lubrication and Maintenance.....	19
<i>Break in Period</i>	19
<i>Daily Maintenance – 8 hours</i>	20
<i>Weekly Maintenance – 40 hours</i>	22
<i>Monthly Maintenance – 250 hours</i>	23
<i>Yearly Maintenance</i>	24
Hydraulic Manifold Layout.....	26
Front Manifold.....	26
Inside Banding Box Manifold.....	27
Outside Banding Box Manifold	28
Electrical Layout.....	29
Front Relay Box (located behind banding drums).....	29
Band Relay Box (located in Banding Box)	30
Display Monitor Troubleshooting Solutions.....	33
Troubleshooting	97

Specifications

Model	100
Dimensions	
Height	9 ft (2.75 m)
Width	8.5 ft (2.59 m)
Length	20 ft (6.09 m)
Weight	7800 lbs (3541 kg)
	Equipped with optional Nitro Boot Unit = 8,400 lbs (3810 kg)
Bale Dimensions	
Length	37 in – 42 in (94 cm – 107 cm)
Height x Width	14 in x 18 in (Makes 21-bale bundle – Default setting)
	16 in x 18 in (Makes 18-bale bundle – See <i>Program Options</i>)
Bundle Dimensions	
Height	4 ft 6 in (54 in)
Width	3 ft 6 in (42 in)
Length	8 ft (21-bale bundle) or 7 ft 10 in (18-bale bundle)
Tires	
Front tires	20.5 x 8.0 x 10-E Hwy Trl TL
Back tires	12.5L x 15 - 8 Ply Tire
Hydraulic Requirements	
PSI	2500 psi (172.3 bar)
GPM	25 gpm (94.6 l/m)
System	closed center
Filter Element Replacement	high pressure element, 6 micron
Tractor Horse Power	Determined by the terrain that you experience
Steel Strapping	
Size	.02 in x .5 in (0.5 mm x 12.5 mm)
Strength	1170 lb (5205 N) break strength, regular duty (not high tensile)
Roll weight	90 lb – 100 lb (41kg – 45 kg) per roll, 29.4 ft/lb
Roll dimensions	16 in ID x 20 in OD x 3 in wide (40 cm ID x 51 cm OD x 7.62 cm)
Recommended supplier	DuBose Strapping & Packaging, 800-354-3021
Baler Twine Strength	Min: 170 lb (756.2 N) knot strength
	Some hay conditions require greater knot strength

Warranty and Service

- ❑ Parts are warranted for one year or 40,000 bales, which ever comes first.
- ❑ Buyer of unit provides/performs service
- ❑ Phone support during Pike Mfg. Corp. (or Bale Band-It Sales Rep.) office hours
- ❑ Towing the Bale Band-It beyond its designed use is the sole responsibility of the buyer.
- ❑ See warranty agreement

Serial Number Location

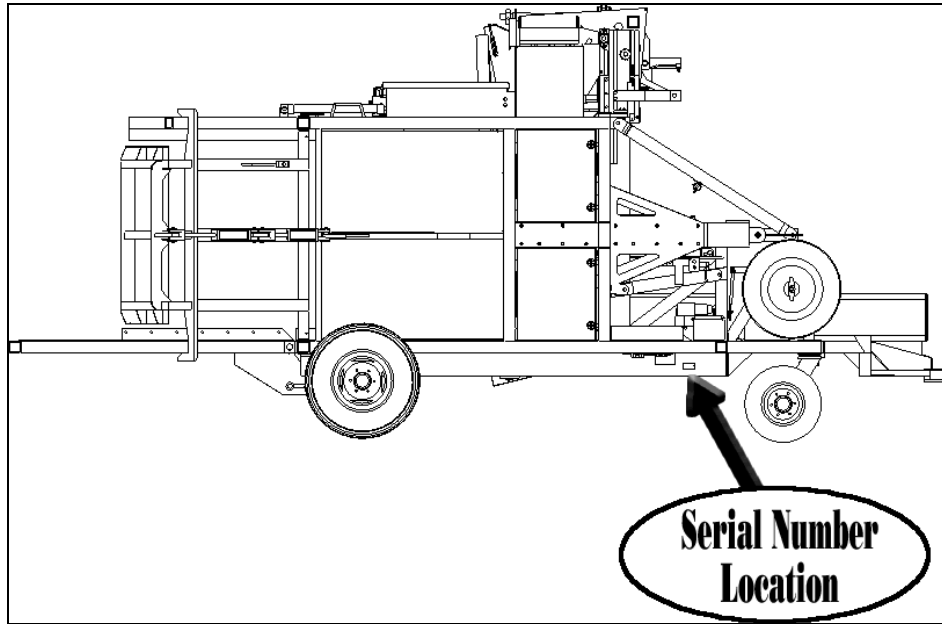

Safety

Bale Band-It Operator Safety

General Precautions

- ❑ Without proper safety precautions, the Bale Band-It has the capability of causing great injury or death to those operating or those near the machine.
- ❑ When parking the Bale Band-It on a slope, ensure machine is facing uphill and chock the rear wheels before unhitching from tractor / baler.

Live Power Precautions

- ❑ Proper disengaging of hydraulic power supply requires turning off tractor remote and turning off engine of tractor.
- ❑ The Bale Band-It is fully computer operated. If hydraulic pressure is supplied to the machine it can and will move at anytime. Disengage hydraulic supply to the machine before approaching.
- ❑ Operator must properly disengage hydraulic supply before troubleshooting, working on, or approaching the machine.
- ❑ The Emergency Shut Off located on the Bale Band-It is an electrical switch that disengages a hydraulic valve. Either the electrical switch or the hydraulic valve has the potential to fail. Therefore, do not rely on this to shut off the hydraulic oil supply. Disengage hydraulic supply to the machine before approaching.
- ❑ When using the reset buttons ensure no-one is near moving parts.

Safety Maintenance Precautions

- ❑ If at any time the Safety Light/Horn located on the machine does not work properly, it must be replaced immediately.
- ❑ Do not operate the machine without all shields in place and all doors properly closed.
- ❑ Mount / attach all hydraulic hoses and cables so that there is sufficient flexibility to turn corners without sharp points, edges or pinch points affecting the hoses and cables.
- ❑ When undertaking daily routine maintenance ensure electric and hydraulic power is off.
- ❑ Keep hydraulic systems clean.
- ❑ Repair all oil leaks immediately.
- ❑ Prevent oil contamination.
- ❑ It is recommended that hay fever sufferers do not clean or maintain the Bale Band-It.
- ❑ The loading of strapping reels should be a 2 man operation.
 - Each reel weighs 90lb – 100lb (41 – 45 kg)

Deviations from Design of Use

The Bale Band-It is designed to be pulled directly behind your small square baler.

- ❑ If machine is to be used in a manner other than that for which it is designed, then it is up to the owner / operator of the machine to ensure that further risk assessments are undertaken and suitable control measures implemented.
- ❑ In the case of using the Bale Band-It as a stationary unit: this may involve the provision of an exclusion zone to prevent personal physical access to parts of the machine that would normally operate safely when towed.

Safety Decals

⚠ CAUTION

Used for general safety practices and reminders

⚠ WARNING

Indicates a specific potential hazard

⚠ DANGER

Indicates specific potential hazard that is most serious

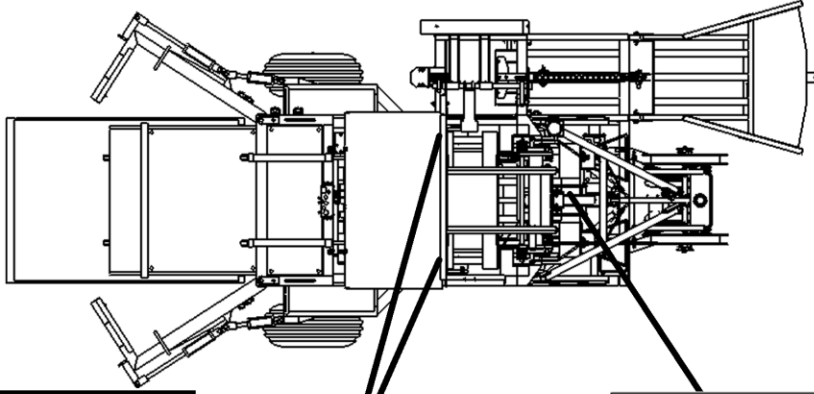

⚠ DANGER
STOP! Before Pressing Reset Buttons Read The Following!

Before pressing "Reset Bundle":

- Open side doors and empty out any holes or loose hay that may obstruct the Horizontal Plunger from fully extending. This will prevent objects from hitting the bottom front of Bundling Box and causing machine damage!
- Check that all persons are clear from unit.
- Check that machine has been electrically and hydraulically powered within the last 2 minutes. This will help ensure that cylinders are not in a "seeped" state.
- Check that Vertical Plunger cylinder has not "seeped" down. If it has, apply electric and hydraulic power to unit until all cylinders are in proper location.
- To prevent chance of bodily harm, ensure that the hydraulic power is discharge from machine.
- Electric power must be engaged in order for "Reset Bundle" button to work.

Before pressing "Reset Strapping":

- Check that all persons are clear from unit.
- To prevent chance of bodily harm, ensure that the hydraulic power is discharge from machine.
- Electric power must be engaged in order for "Reset Strapping" button to work.
- Check that new rolls of strapping are threaded prior to pressing reset.

When machine automatically stops due to bundle count reaching zero (End of Strapping), machine will remain in a paused state until one of the reset buttons are pressed. Therefore, machine will move immediately after a reset button is pressed.

Note: "Reset Strapping" only changes the bundle counter on Tractor Monitor and does not effect the bale count in the machine.

⚠ DANGER

To prevent serious injury or death from pinching:

- Keep all persons and objects clear while any part of this machine is in motion.

⚠ CAUTION
NO STEP

⚠ DANGER

To prevent serious injury or death from pinching:

- Disconnect and lockout power source before threading steel strapping
- Keep all persons and objects clear while any part of this machine is in motion.

⚠ CAUTION

To Avoid Injury Or Machine Damage:

- When servicing machine use proper tools and equipment.
- Refer to operations manual for instructions.

⚠ DANGER

To prevent serious injury or death from pinching:

- Stay away from back gates when machine is in operation.
- Keep others away.
- Do not operate machine when bystanders are present.

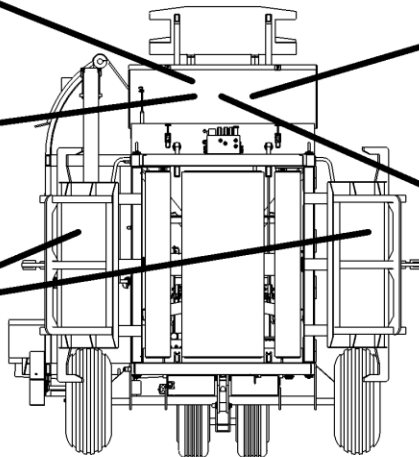

⚠ DANGER
MOVING PART HAZARD

To prevent serious injury or death from moving parts:

- Close lid before starting operation
- Keep hand, feet, hair and clothing away from moving parts.
- Disconnect and lockout power source before adjusting or servicing
- Do not stand or climb on machine when operating.

VERSION 2005-09-28

Safety Decals

⚠ DANGER



To prevent serious injury or death from pinching:

- Keep all persons and objects clear while any part of this machine is in motion.

⚠ CAUTION

DO NOT RIDE

⚠ WARNING

MOVING PART HAZARD

To prevent serious injury or death from moving parts:

- Close doors before starting operation.
- Keep hand, feet, hair and clothing away from moving parts.
- Disconnect and lockout power source before adjusting or servicing
- Do not stand or climb on machine when operating.

⚠ WARNING



To prevent serious injury or death falling:

- Do not stand on or around when machine is operational.
- Keep all persons and objects clear while any part of this machine is in motion.

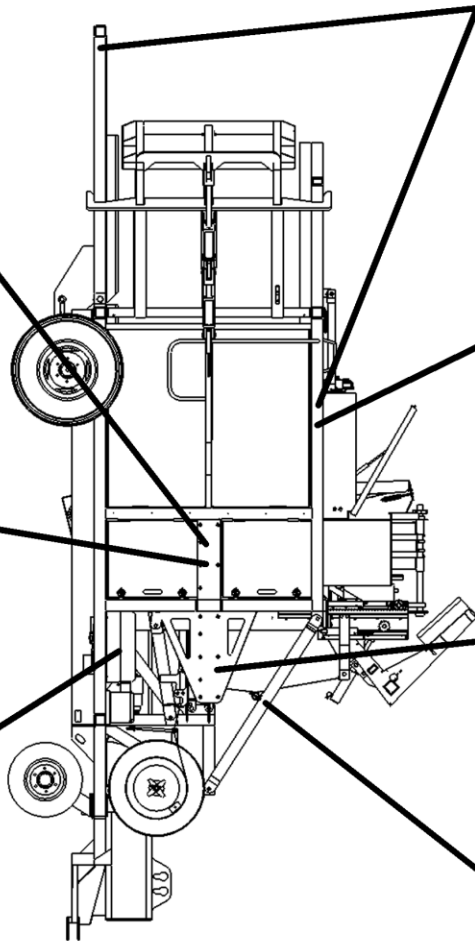

⚠ DANGER



To prevent serious injury or death from pinching:

- Disconnect and lockout power source before threading steel strapping
- Keep all persons and objects clear while any part of this machine is in motion.

⚠ DANGER



To Prevent Serious Injury Or Death From Moving Parts:

- **KEEP AWAY**, Moving parts can crush and dismember.
- Do not operate without guards and shields in place.
- Disconnect and lockout power source before adjusting and servicing.

⚠ CAUTION



To Avoid Injury Or Machine Damage:

- When servicing machine use proper tools and equipment.
- Refer to operations manual for instructions.

VERSION 2005-09-28

Safety Decals

⚠ DANGER

COMPLETELY AUTOMATED EQUIPMENT

The BALE BAND-IT is completely computer operated and can move at ANY time.
To Prevent Serious Injury Or Death From Moving Parts:

- KEEP AWAY, Moving parts can crush and dismember.
- Do not operate without guards and shields in place.
- Disconnect and lockout power source before adjusting and servicing.
- Read operator's manual before operating equipment.



⚠ CAUTION

To Avoid Injury Or Machine Damage:

- When servicing machine use proper tools and equipment.
- Refer to operations manual for instructions.

⚠ DANGER



To prevent serious injury or death from pinching:

- Disconnect and lockout power source before threading steel strapping
- Keep all persons and objects clear while any part of this machine is in motion.



⚠ WARNING

To prevent serious injury or death falling:

- Do not stand on or around when machine is operational.
- Keep all persons and objects clear while any part of this machine is in motion.

⚠ CAUTION

NO STEP

⚠ DANGER



To prevent serious injury or death from pinching:

- Keep all persons and objects clear while any part of this machine is in motion.

⚠ DANGER



To Prevent Serious Injury Or Death From Moving Parts:

- KEEP AWAY, Moving parts can crush and dismember.
- Do not operate without guards and shields in place.
- Disconnect and lockout power source before adjusting and servicing.



⚠ WARNING

To prevent serious injury or death falling:

- Do not stand on or around when machine is operational.
- Keep all persons and objects clear while any part of this machine is in motion.

⚠ CAUTION

DO NOT RIDE

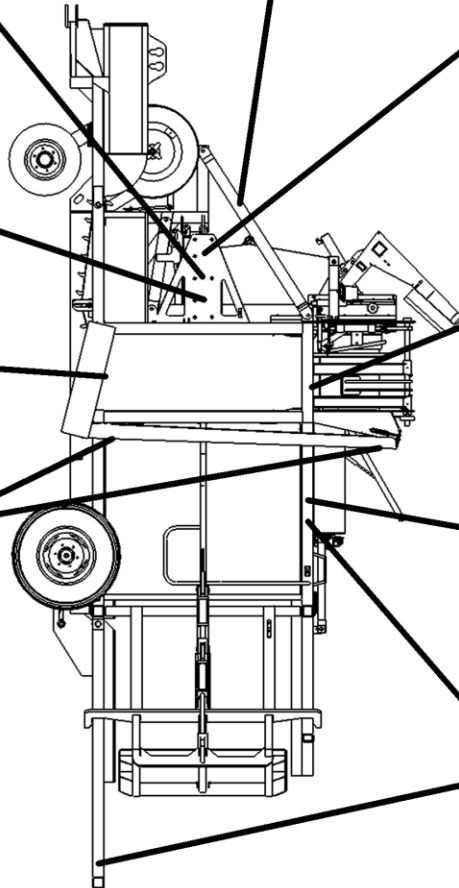

VERSION 2005-09-28

Chain Guards		Rev: 2005-10-01	
ITEM	QTY	PART NUMBER	DESCRIPTION
1	1	1-M-0018	Vertical Elevator Chain Guard
2	1	1-M-0007	Horizontal Elevator Drive Chain Guard
3	1	1-M-0014	Strap Guide Drive Chain Guard

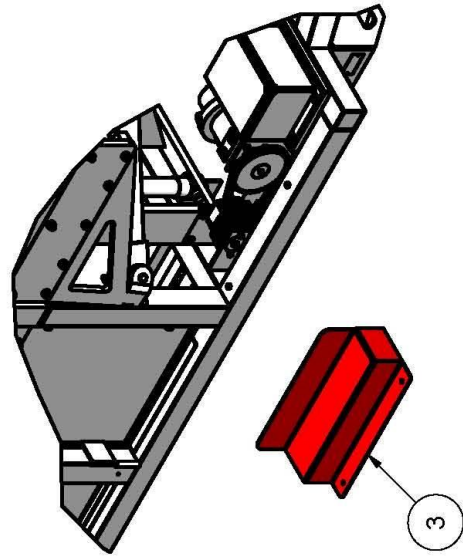
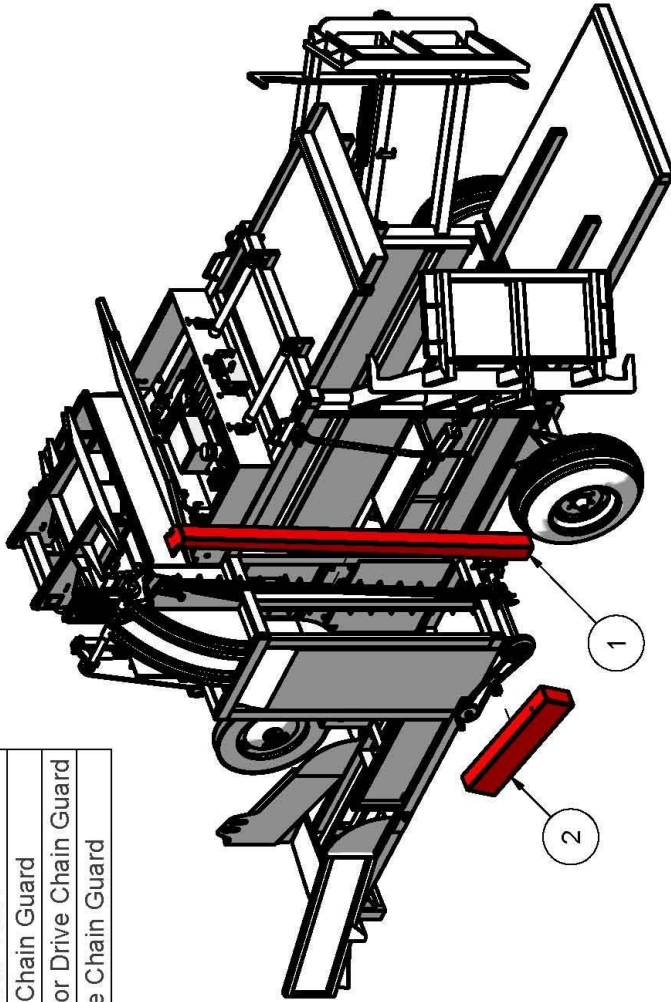

OPERATOR SAFETY:

TURN OFF TRACTOR BEFORE REMOVING ANY GUARDS.
 DO NOT OPERATE THE MACHINE WITHOUT ALL SHIELDS
 IN PLACE AND ALL DOORS PROPERLY CLOSED.
 REPLACE ANY MISSING OR DAMAGED GUARDS.

Hooking Up

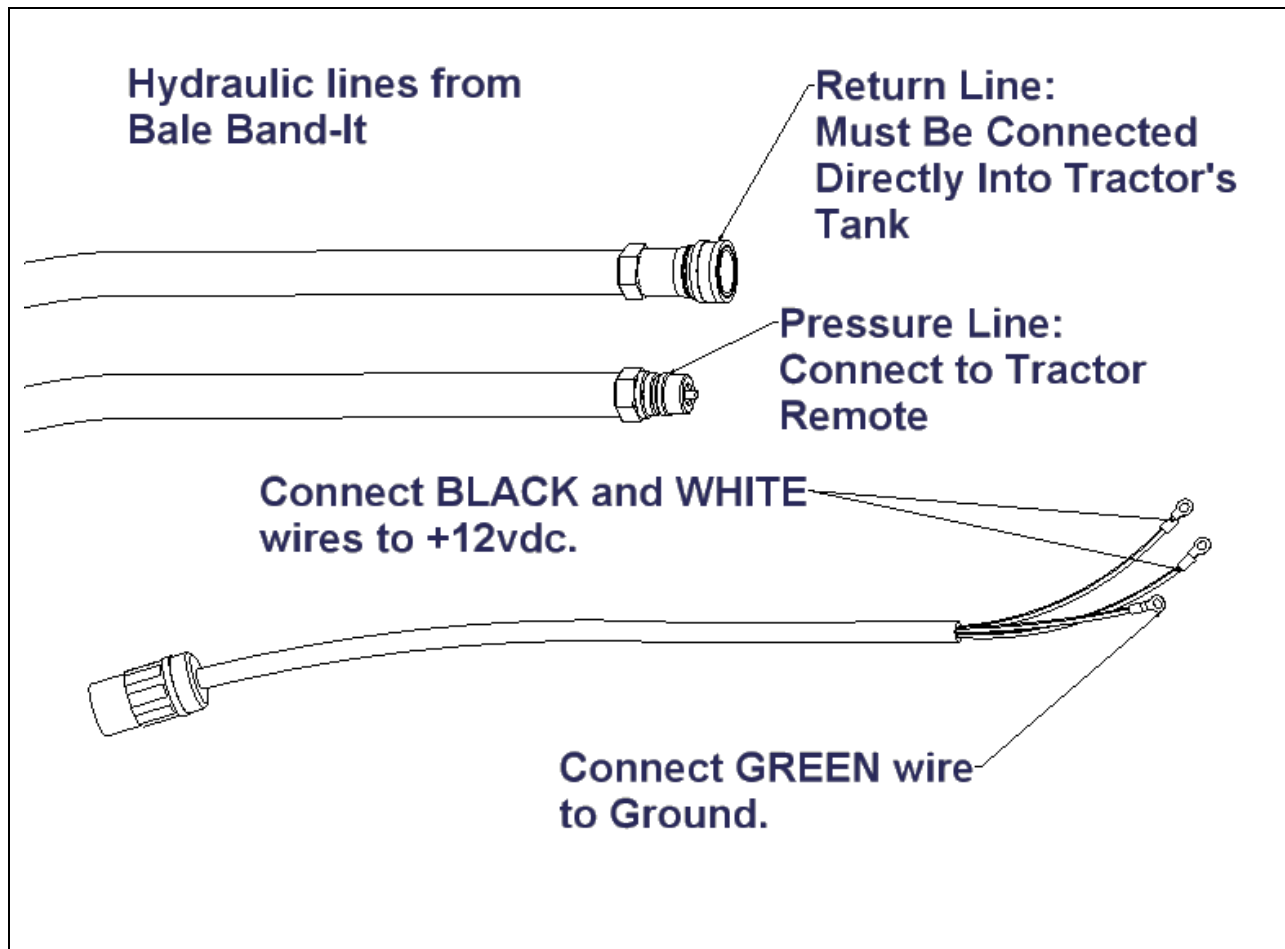

- ❑ The Bale Band-It is connected to the baler hitch. All baler chute extensions must be taken off the baler. The center of the pin hole in the baler hitch needs to be adjusted 8-10 inches (20 cm – 25 cm) from the main chamber of the baler.
- ❑ Pike Mfg. Corp. provides all electrical cables and connectors needed for operation.
- ❑ The 10' (3 m) electrical cable (10 gauge, 3 conductor) with terminal ends is to be attached to a 12-volt DC power supply (battery of tractor). This cable consists of 3 separate insulated wires. The black and white wires are to be attached to the +12-volt DC and the green wire is to be attached to the -12-volt DC.
- ❑ Pike does not provide the two hydraulic hoses that are to be attached onto the baler. These hydraulic hoses go from the tractor to the Bale Band-It and must be 1 inch (25.4 mm) ID hoses. Anything less than 1 inch (25.4 mm) ID will not allow proper hydraulic flow to the machine and will slow performance. It is recommended that 1 inch (25.4 mm) male pipe thread ends be crimped on one end of each of the two hoses mounted on the baler. This will allow for the provided couplers to be attached to the hoses.
- ❑ Pike provides one set of 1 inch (25.4 mm) pipe thread male/female couplers. These couplers are to be used to connect to the existing hydraulic couplers located on the front chute of the machine to the hoses mounted on the baler.
- ❑ An additional set of 1 inch (25.4 mm) pipe thread male/female couplers can be purchased from Pike to provide an easy connection from baler hose return to tractor reservoir.

- When attaching hydraulic hoses to tractor, it is very important that the pressure line is attached to the tractor remote and the tank line is attached directly to the reservoir of the tractor. The Bale Band-It filters the pressure line right before it enters the first hydraulic valve manifold. This filter is located between the white Banding Drums. Be certain that the line coming from this filter (the pressure line) is connected to the tractor remote. Reversing the pressure line and the return line can cause damage to the machine. The return line DOES NOT connect to the tractor remote. The return line must connect directly to the reservoir of the tractor with NO BACK PRESSURE! Back pressure will not allow the Bale Band-It to work properly. Back pressure is the most common mistake made in hooking up the Bale Band-It. The return line CANNOT be connected directly to the remote or ran through a return kit. It must be connected directly to the tank of the tractor or through the fill cap WITHOUT restriction.
- Mount hoses on baler so that while turning corners the hoses are not crimped, cut or stretched between the tractor and baler and between the baler and Bale Band-It. Also mount hoses away from any sharp points or edges to prevent cutting or damaging hoses.
- Mount the Bale Band-It Monitor in the tractor. When mounting the monitor in the tractor, the suction cups or stationary bracket can be used. If using suction cups to mount monitor, be sure to wet both suction cups for secure mounting to glass or similar surface. When connecting the 12 vdc power to the monitor, the cigarette lighter power adapter or the leaded cord assembly can be used. If the leaded cord assembly is used, be sure the ‘dashed’ lead is connected to the positive (+) pole of the 12 vdc supply. If polarity is reversed damage to the monitor may occur.
- Thread strapping into Bale Band-It
 - See “Threading Process”

Bale Band-It Threading Instructions

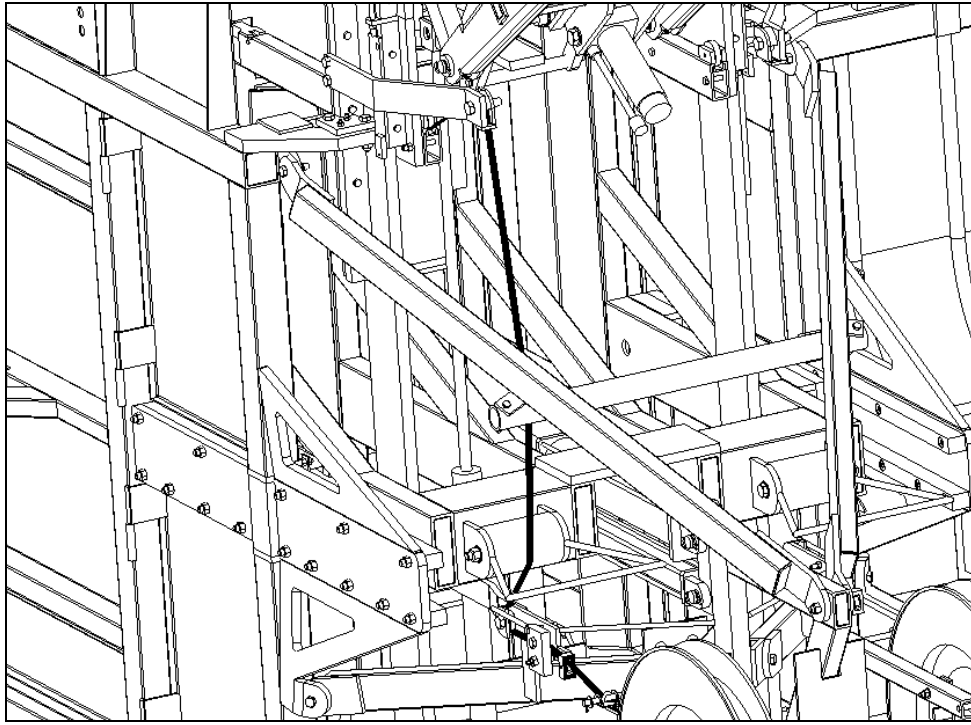

1. When placing the rolls of strapping on the white banding drums, the end of the strap must come off of the top of the roll.

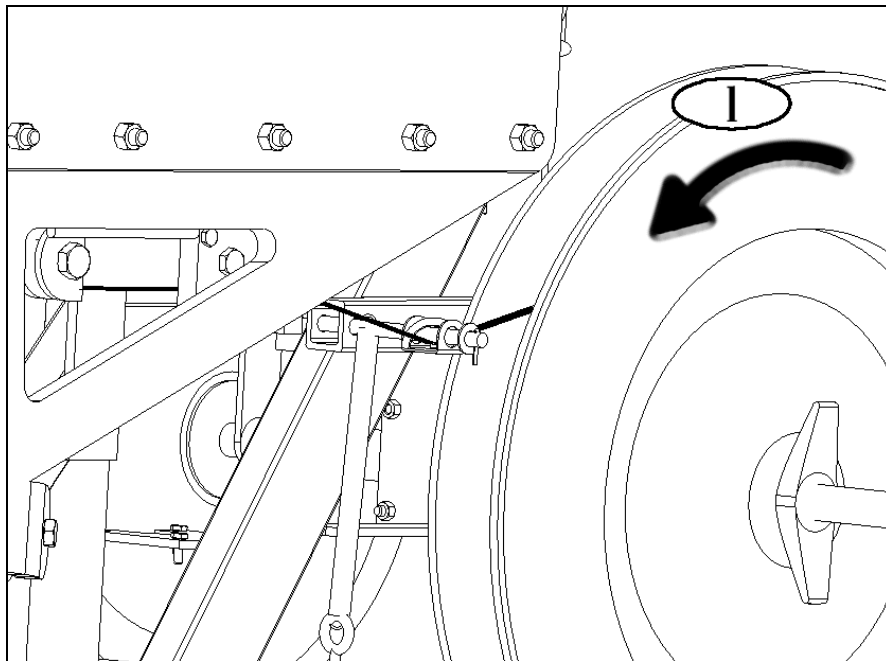

2. Thread the strap between the $\frac{1}{2}$ " (12.5 mm) rod and the spring loaded strap guide attached to the banding drum brake arm. The strap should be under the $\frac{1}{2}$ " (12.5 mm) rod and on top of the spring loaded strap guide.

3. Thread the strapping on top of the roller but under bolt.

4. Thread the strapping between the Upper Crimper Roller and the lower bearing mounted on the Strap Crimper.

5. Thread the strapping around the next bearing, starting from the bottom of the bearing. For easier threading, bend an upward radius in the strapping. This will allow the strapping to flow easily around the bearing.

6. Thread the strapping inside of the Rod Frame and against the large roller mounted on the Horizontal Plunger.

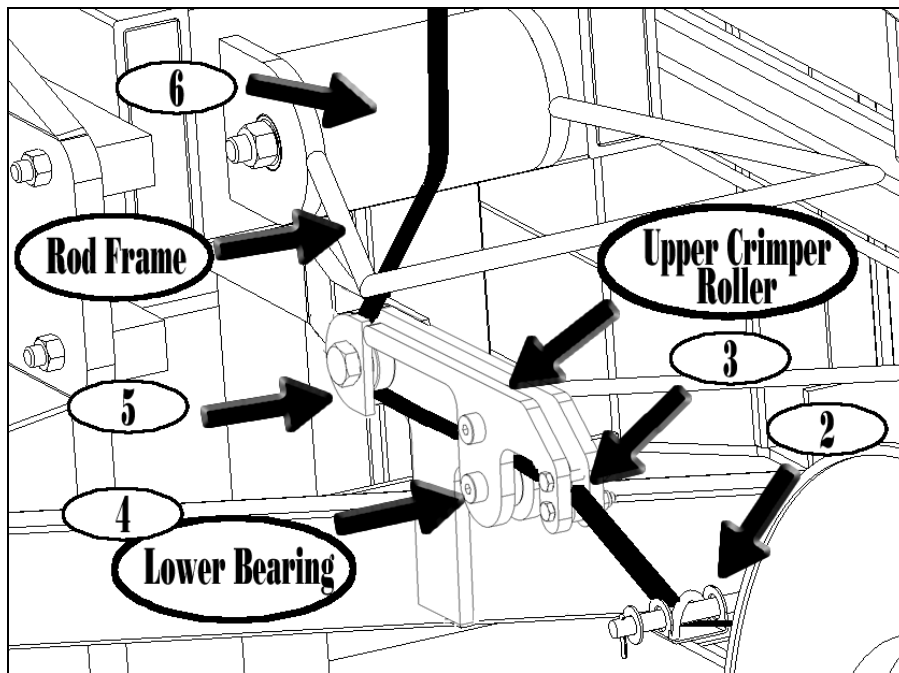

7. Thread the strapping through the slot mounted to the pipe located on the upper braces.

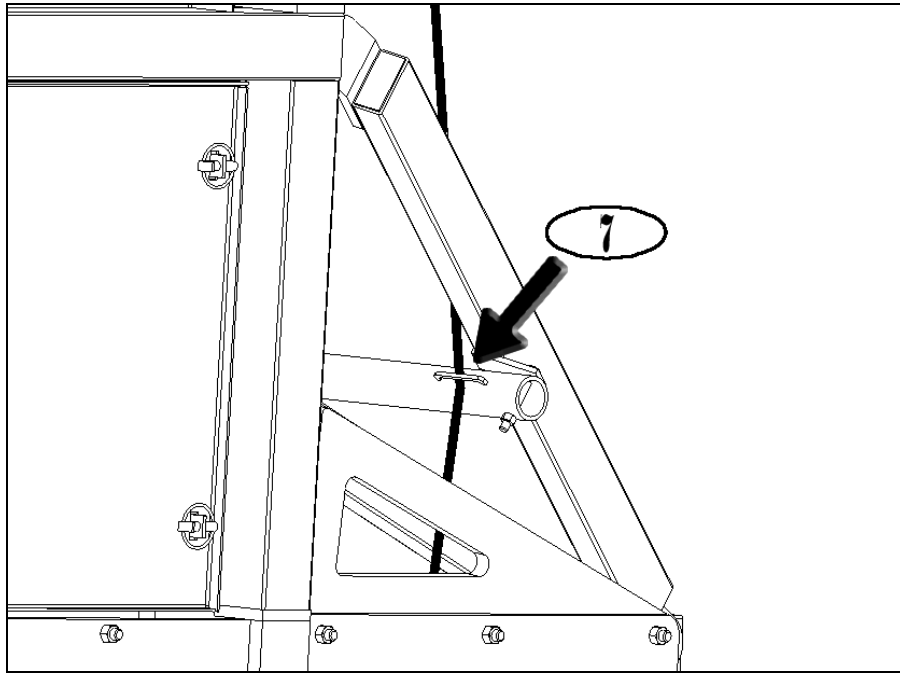

8. Thread the strapping through the slot under the bearing.

9. Thread the strapping around the bearing. For easier threading, bend a radius in the strapping. This will allow the strapping to flow easily around the bearing.

10. Thread the strapping under the roller and in the channel of the Strap Guide Arms. For easier threading, straighten the strapping before threading under the roller. This will allow the strapping to flow easily through the Strap Guide Arm and out the other side.

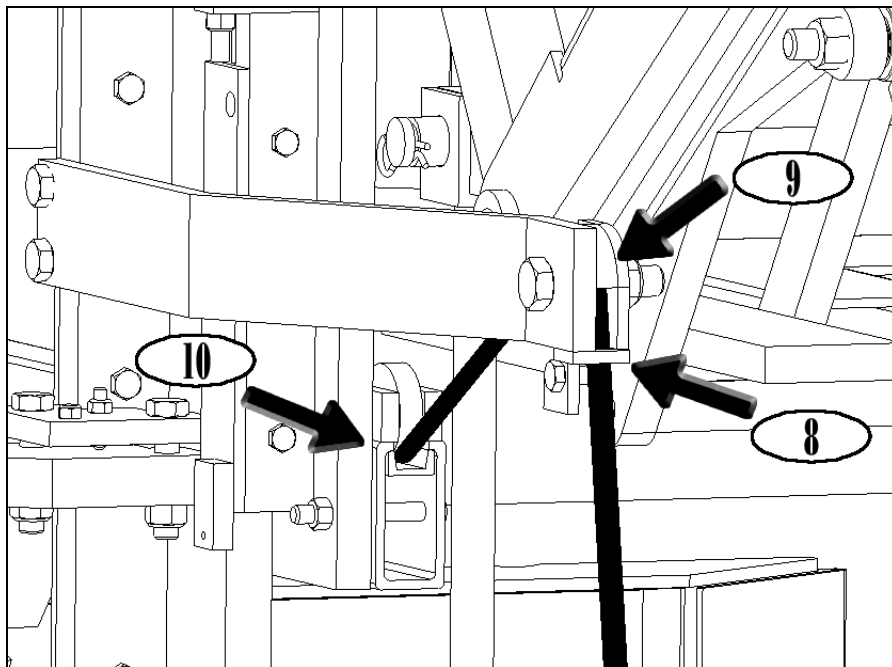

11. As the strapping is being threaded through the Strap Guide Arm, it must be threaded on top of the pivot point of the Strap Guide Arm Finger.

12. Thread the strapping on top of the roller mounted at the end of the Strap Guide Arm Finger.

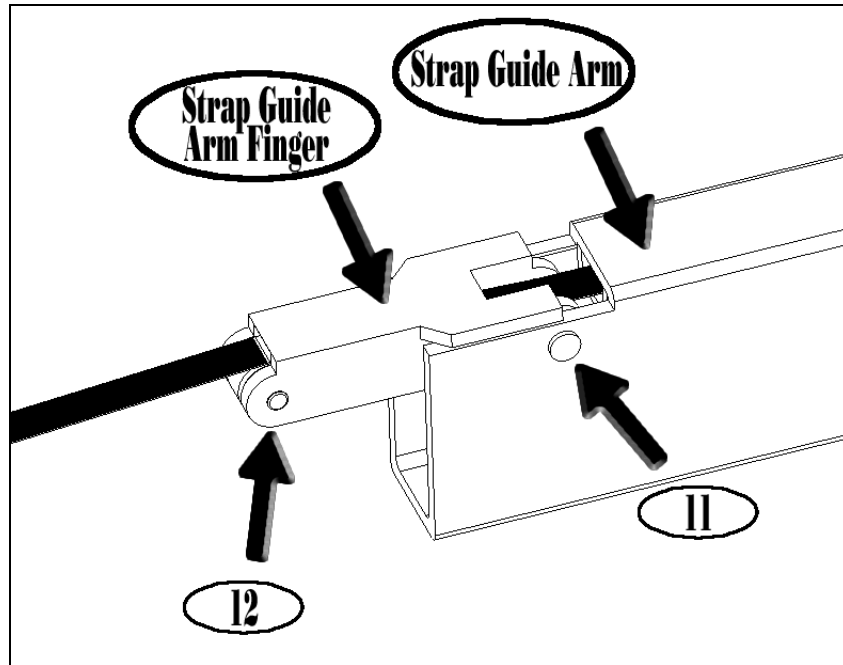

13. Pull approximately 30" (0.75 m) of strapping from the Strap Guide Arm Finger.

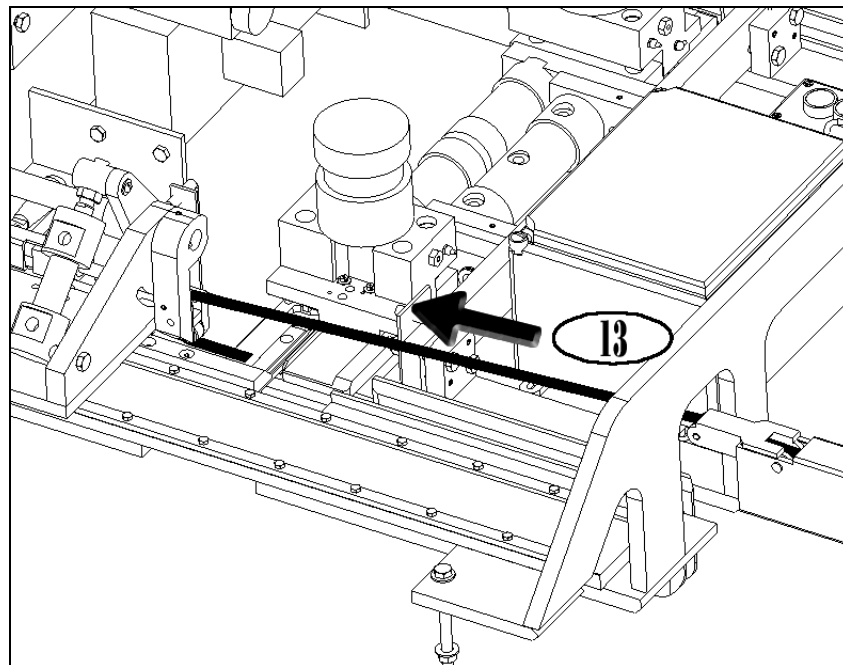

14. Release the tension on the red handled clamp by pulling the handle back.

15. Pull back on the spring-loaded gripper using the finger handle.

16. Pre-bend the strapping into a “C” shape. As the spring-loaded gripper is being pulled back, slide the strapping around the side in the direction of the arrow labeled “16”. At this point the strapping should be located around the 2 rollers mounted on the bottom of the Fetcher Casting.

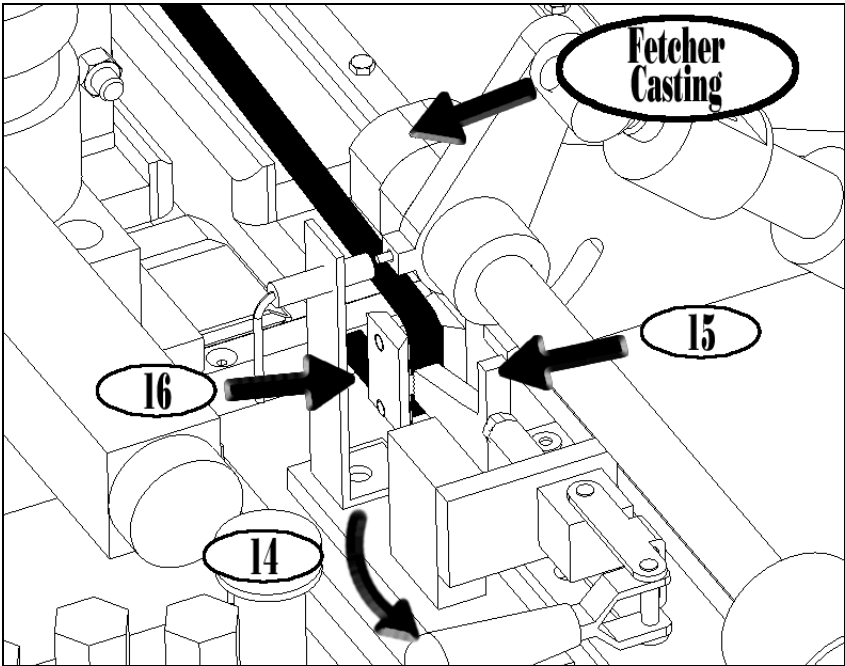

17. The end of the strapping needs to be located within +/- 1/4” (6 mm) of the area specified by the arrow labeled “17”. Release the spring-loaded gripper and re-apply tension to the red handled clamp. The amount of tension on the red handled clamp can be adjusted by adjusting the bolt mounted in the end of the clamp.

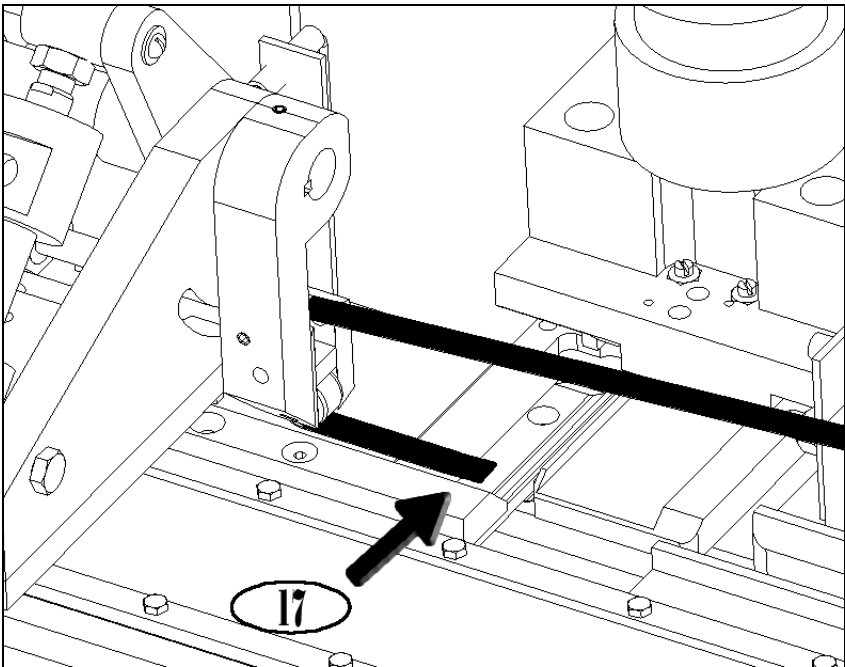

Concepts of Operation

Sequence of Events

The Bale Band-It does not move until activated by an incoming bale. It will then perform a series of operations that correspond to where the machine is at in the 21 bale process.

1. Bale 1 loaded into stacking chamber at Bale Position 1.
2. Bale 2 loaded into stacking chamber at Bale Position 2.
3. Bale 3 loaded into stacking chamber at Bale Position 3.
 - a. Horizontal plunger pushes the 3 bales in stacking chamber, rearward into the main chamber.
4. Bale 4 loaded into stacking chamber at Bale Position 1.
5. Bale 5 loaded into stacking chamber at Bale Position 2.
6. Bale 6 loaded into stacking chamber at Bale Position 3.
 - a. Horizontal plunger pushes the 3 bales in stacking chamber, rearward into the main chamber.
7. Bale 7 loaded into stacking chamber at Bale Position 1.
8. Bale 8 loaded into stacking chamber at Bale Position 2.
9. Bale 9 loaded into stacking chamber at Bale Position 3.
 - a. Horizontal plunger pushes the 3 bales in stacking chamber, rearward into the main chamber.
10. Bale 10 loaded into stacking chamber at Bale Position 1.
11. Bale 11 loaded into stacking chamber at Bale Position 2.
12. Bale 12 loaded into stacking chamber at Bale Position 3.
 - a. Horizontal plunger pushes the 3 bales in stacking chamber, rearward into the main chamber.
 - b. Back floor drops, lowering the previously made bundle of 21 small square bales to the ground. The bundle then unloads with ground travel.
13. Bale 13 loaded into stacking chamber at Bale Position 1.
14. Bale 14 loaded into stacking chamber at Bale Position 2.
 - a. Back floor raises to horizontal position.
15. Bale 15 loaded into stacking chamber at Bale Position 3.
 - a. Horizontal plunger pushes the 3 bales in stacking chamber, rearward into the main chamber.
 - b. Back gates close.
16. Bale 16 loaded into stacking chamber at Bale Position 1.
17. Bale 17 loaded into stacking chamber at Bale Position 2.
18. Bale 18 loaded into stacking chamber at Bale Position 3.
 - a. Horizontal plunger pushes the 3 bales in stacking chamber, rearward into the main chamber.
19. Bale 19 loaded into stacking chamber at Bale Position 1.
20. Bale 20 loaded into stacking chamber at Bale Position 2.
21. Bale 21 loaded into stacking chamber at Bale Position 3.
 - a. Horizontal plunger pushes the 3 bales in stacking chamber, rearward into the main chamber, and compresses the 21 bale bundle.
 - b. The bundle is tied with 2 steel bands
 - c. Back gates open, allowing exit of newly created bundle
22. Bale process starts over and repeats the sequence of events again.

Bundles are tied with steel bands on bale 21. Bundles are unloaded on bale 12 of the next bundle.

Manual Overrides

Manual Bundle Removal

There is a push button and toggle switch located on the right side of machine. The switches intended purpose is to manually remove a completed bundle from the main chamber. The push button labeled **PLUNGER** manually moves the horizontal plunger. This button is a momentary switch and must be held down in order for plunger to complete full stroke of cylinders. The toggle switch labeled **BACK FLOOR** manually lowers the back floor.

The **PLUNGER** button will have no effect if the Horizontal Plunger solenoid is currently activated (Horizontal Plunger cylinders will be stroked out when activated). The Horizontal Plunger will remain activated until the first bale of every bundle has entered the machine. If Horizontal Plunger is activated and removing of a bundle is desired, simply run one more bale through the Bale Band-It.

The **BACK FLOOR** toggle switch should **never** be activated if the Back Gates are closed! The Back Gates close on the 5th tier (bale 15) of the bundle and reopen after the banding process has been completed for that bundle. If Back Gates are closed and the removing of bales is desired one of two things can be done: (1) run more bales through the machine to complete the bundle or (2) simply press the Bundle Reset button.

To remove a completed bundle:

- Check that Back Gates are open and that Horizontal Plunger is not activated.
- Open the side doors of machine and insert one small square bale with the edge up into the Horizontal Plunger chamber (the same direction as all the other bales).
- Close all side doors and properly fasten them.
- Hold down **PLUNGER** button until Horizontal Plunger is at end of its stroke and release.
- Insert another bale into chamber and repeat the above process until the entire bundle is sitting on the Back Floor.
- Activate the **BACK FLOOR** toggle switch. The bundle should now be partially on the ground. Pull the machine out from under the bundle.
- Deactivate the **BACK FLOOR** toggle switch and properly fasten all side doors.

Strapping Count

‘Out of Strapping’ displayed and buzzer on tractor box: This display will appear after 122 bundles have gone through the Bale Band-It. Two new rolls of strapping will band together approximately 122 bundles. This is not an exact count due to the fact that each bundle will vary in the amount of strapping that it will use. If the display shows **‘Out of Strapping’** and the buzzer is on, the **Reset Strapping** button must be pressed in order for the Bale Band-It to continue. Once this has been done the computer resets its strapping counter to 122. If the buzzer is on and there is still enough strapping to do more bundles, press the **Reset Strapping** button and continue baling. Be sure to keep a close watch on the amount of strapping that you still have to prevent the possibility of running out. Be sure to press the **Reset Strapping** button anytime two new rolls of strapping have been put onto the machine.

Reset Strapping Button

Press when the two new rolls of strapping have been replaced on the machine. This resets the computer’s bundle count in order to turn on the tractor box buzzer at the appropriate time. If the tractor box buzzer is turned on, the Bale Band-It will not proceed with operations until the Reset Strapping button has been pressed.

Reset Bundle Button

THINK SAFETY! STAY AWAY from moving parts when using **RESET BUNDLE BUTTON!**

Do not reset if people are close to moving parts.

Do not reset if vertical plunger swing is open and vertical plunger has seeped down on top of horizontal plunger. Turn hydraulics on and vertical plunger will go to raised position, then reset.

Do not reset if bale is not completely below banding box. **TURN HYDRAULICS OFF** then remove bale before resetting.

Do not reset when fetcher cylinders are extended and hydraulics are turned off. Turn hydraulics on then reset.

Reset Bundle Button: Press when you want to start a new bundle. It is best to empty the elevator chamber and front chamber (from the side doors) before resetting the bundle. This will allow the Strap Guide Arms to go up without trying to raise bales up with it. Anytime the Reset Bundle has been pressed, the strapping will need to be re-threaded. Reset Bundle does not need to be used during regular use of the machine. Some exceptions may be:

- If strapping runs completely out and there are bales in any of the Bale Band-It chambers.
- If a foreign object has entered the Bale Band-It and has disturbed the bundle.

In either case, bales will need to be cleaned out, Bundle Reset pressed, and strapping re-threaded.

After resetting, remove banding from fetcher strap gripper and rethread strapping from the strap guide finger to fetcher strap grippers.

After resetting, make sure all loose bales are out of the Bale Band-It before bale 15 enters the machine. This is important because the Back Gates close after bale 15 has entered the main chamber. (**Turn off hydraulics before removing loose bales.**)

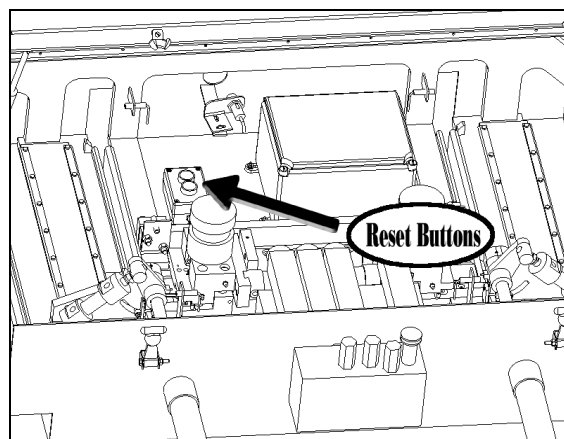

Lubrication and Maintenance

WHEN DOING MAINTENANCE MAKE SURE MACHINE'S ELECTRIC IS UNHOOKED AND HYDRAULIC POWER IS SHUT OFF.

REPAIR ALL OIL LEAKS IMMEDIATELY

PREVENT OIL CONTAMINATION

KEEP HYDRAULIC SYSTEM CLEAN!

Prevent contamination when changing filters, hoses, etc. Always clean the area around the components. The system has a high pressure 6 micron filter to keep contamination out of precision valves.

Caution

An oil or trash covered machine is a fire hazard.
Ensure all combustible materials are cleared daily.

Break in Period

Wheels & Lugs

Torque = 85 – 100 ft-lb (115.24 - 135.58 N-m)

After First 4 hours of operation
Tighten lugs on wheels

After First 8 hours of operation
Tighten lugs on wheels

Within the First 100 hours of operation
Check torque of lugs on wheels frequently

Lower chrome rail bolts

Located on Bale Band-It Parts Section 120 Page 8
After first 8 hours of operation
Check tightness of bolts

Within the First 100 hours of operation
Check tightness of bolts frequently

Horizontal plunger roller nuts

Located on Bale Band-It Parts Section 130 Page 1
After first 8 hours of operation
Check tightness of bolts

Within the First 100 hours of operation
Check tightness of bolts frequently

Strap guide arm chains

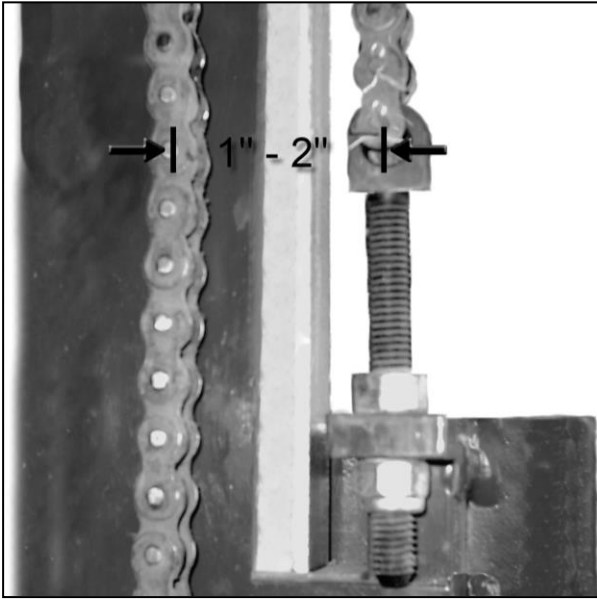

Check after first 8 hours of operation. Continue to check after each additional 8 hours of operation, until the chains stay tight.

Procedure: The best time to tighten the strap guide arm chain is when the strap guide arms are in bale position one. This will give you a bale count of 1, 4, 7, 10, 13, 16, or bale 19.

Check the spacing between the chains by taking the slack out with your hand. Correct spacing = 1 inch – 2 inches (25.4mm – 50.8mm). If the spacing is not correct then loosen the locking (upper) nut. Tighten the tightening (lower) nut and check the spacing between the chains, until you reach the correct dimension. After

adjusted properly retighten the locking (upper) nut. Repeat procedure for other strap guide arm.

Horizontal Elevator Chain

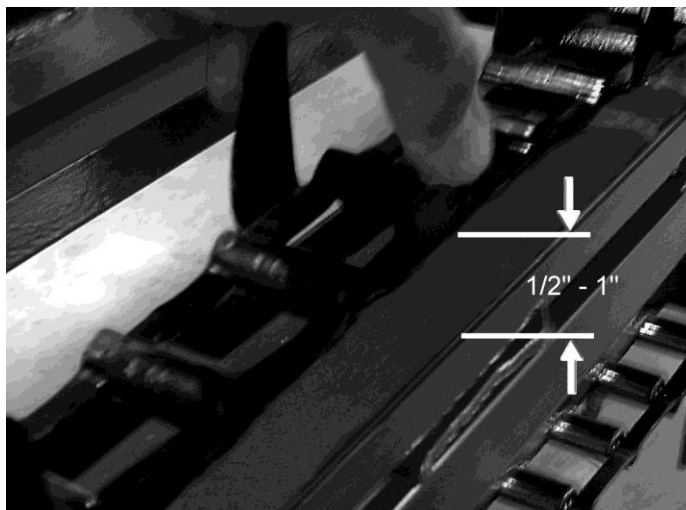

Check after first 8 hours of operation. Continue to check after each additional 8 hours of operation, until the chain stays tight.

It is recommended to have a raised chain dimension between ½ inch - 1 inch (12.5 mm – 25.0 mm).

Vertical Elevator Chain

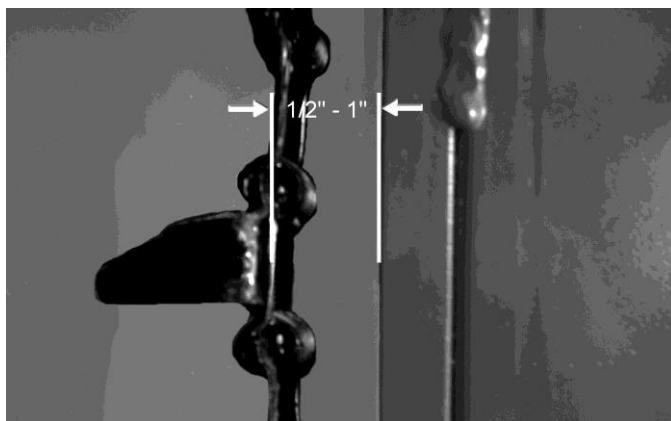

Check after first 8 hours of operation. Continue to check after each additional 8 hours of operation, until the chain stays tight.

It is recommended to have a raised chain dimension between ½ inch - 1 inch (12.5 mm – 25.0 mm).

Daily Maintenance – 8 hours

Cleanliness

The entire Bale Bandit should be cleaned of all hay and chaff daily.

Give special attention to the banding box. Clean around the four guide posts of the banders.

Compressed air is the fastest and most effective way to remove trash.

Clean the three photo eye sensors, making sure all oil and grease is removed.

Fasteners

Check for loose bolts and fasteners. If bolt/nut is loose or removed replace with Loctite or new lock nut.

Lubrication

Lubrication Location	Time Frame (hours)	# of Zerts
Front caster wheel	8	2
Vertical plunger swing cylinder	8	2
Vertical plunger main pivot	8	2
Kicker cylinder yoke	8	1
Kicker rotation shaft	8	2
Horizontal Elevator	8	1
Vertical elevator	8	1

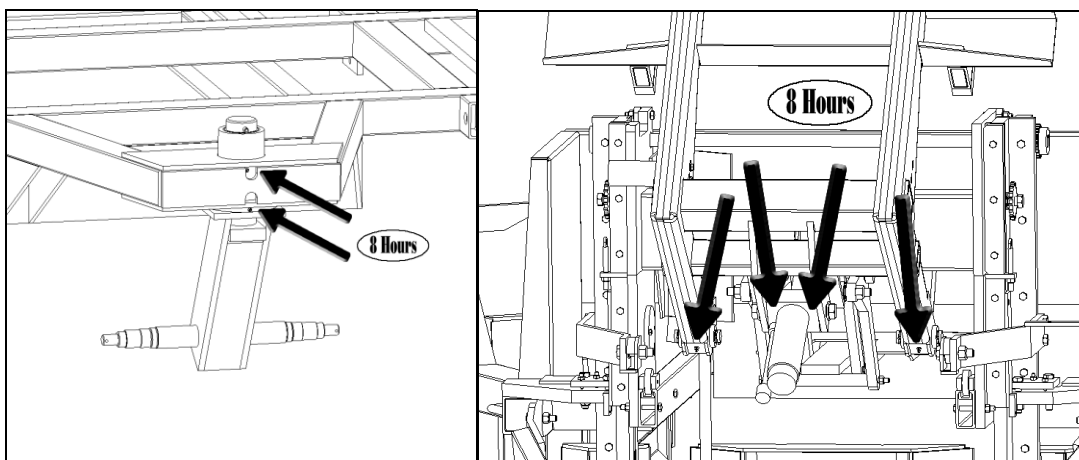

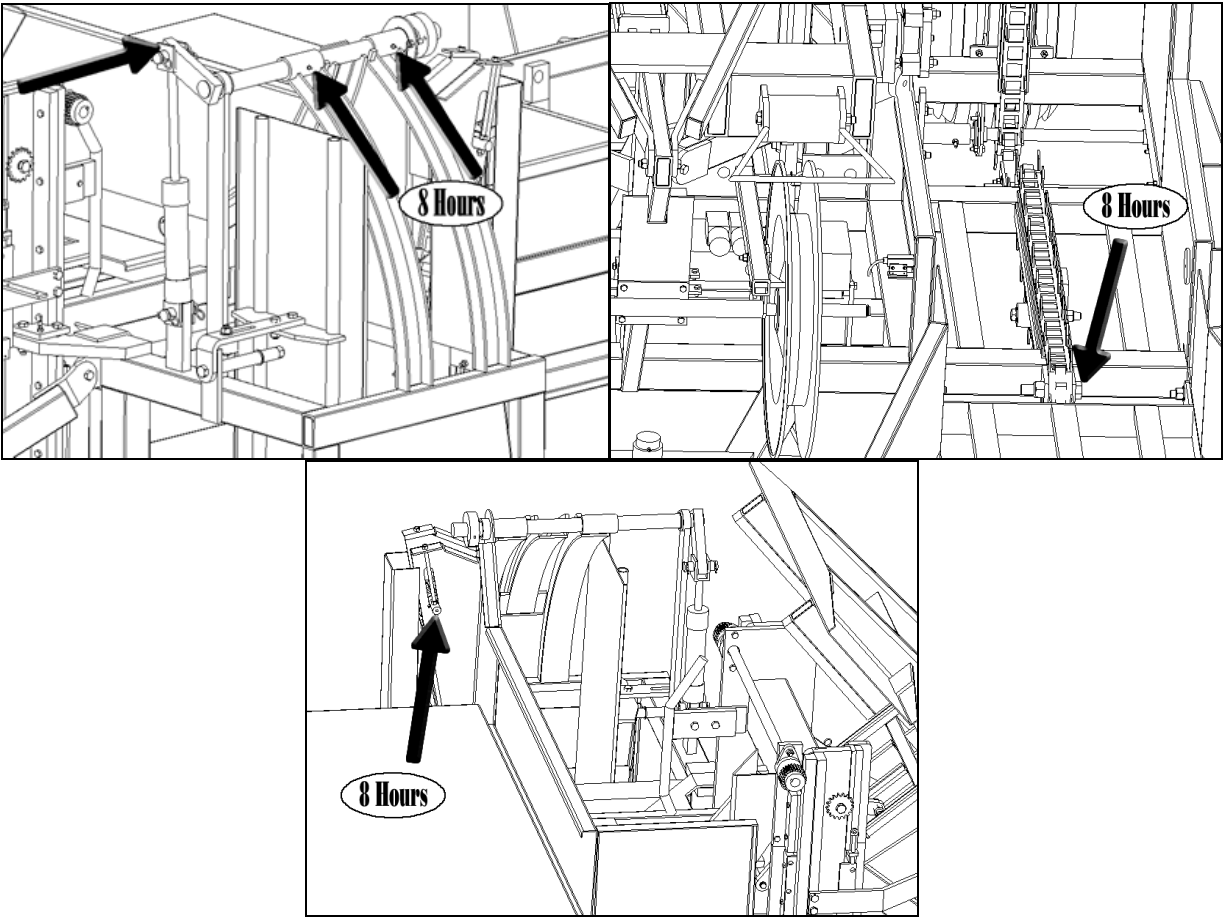

Weekly Maintenance – 40 hours

Strap guide arm chains

Procedure: The best time to tighten the strap guide arm chain is when the strap guide arms are in bale position one. This will give you a bale count of 1, 4, 7, 10, 13, 16, or 19.

Refer to Break in Period for complete procedure.

Horizontal Elevator Chain

It is recommended to have a raised chain dimension between ½ inch - 1 inch (12.5 mm–25.0 mm). Refer to Break in Period for complete procedure.

Vertical Elevator Chain

It is recommended to have a raised chain dimension between ½ inch - 1 inch (12.5 mm–25.0 mm). Refer to Break in Period for complete procedure.

Lubrication

Lubrication Location	Time Frame (hours)	# of Zerts
Back gates	40	4
Banders	40	8
Back floor	40	2

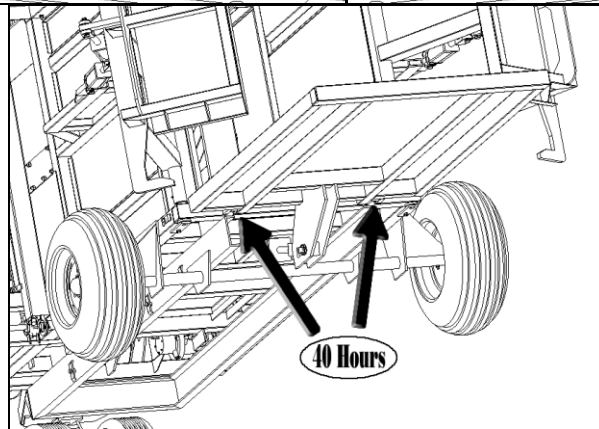
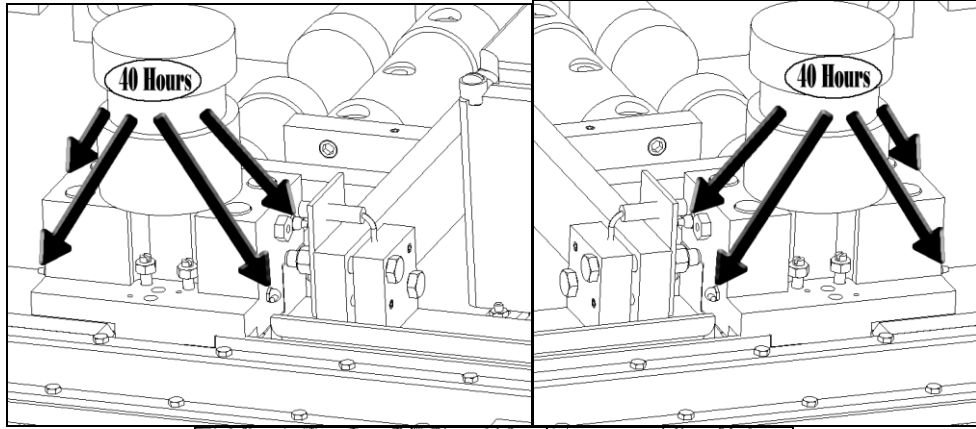
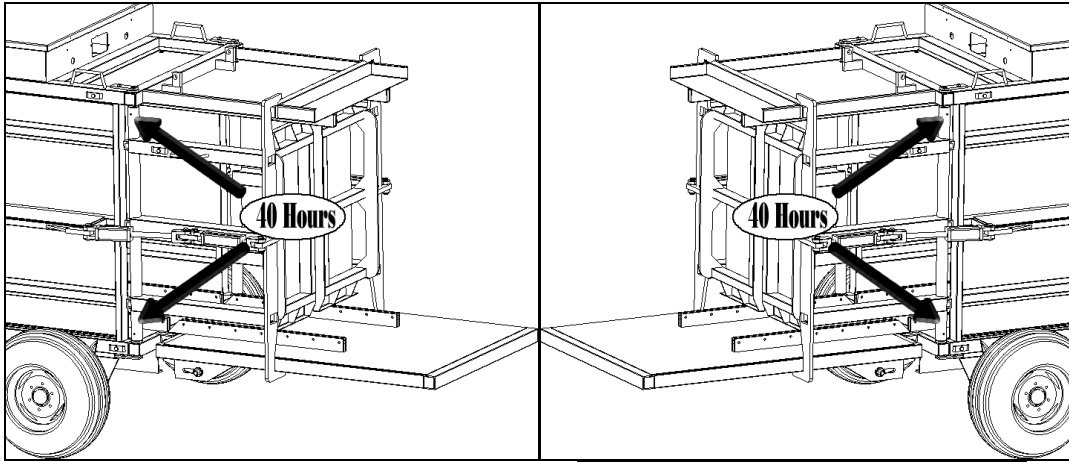

Monthly Maintenance – 250 hours

Wheels & Lugs

Tighten lugs on wheels

Torque = 85 – 100 ft-lb (115.24 - 135.58 N-m)

Lower chrome rail bolts

Located on Bale Band-It Parts Section 120 Page 8

Check tightness of bolts

Horizontal plunger roller nuts

Located on Bale Band-It Parts Section 130 Page 1

Check tightness of bolts

Yearly Maintenance

Hydraulic oil

Due to viscosity breakdown, change hydraulic oil once a year.

Vertical Plunger gear & rack clearance Check

Gear and rack clearance needs to be between 0.020 inch (0.51 mm) min – 1/16 inch (1.6 mm) max.

If gear and rack clearance is greater than 1/16 inch (1.6 mm) then the gear can jump a tooth and cause the vertical plunger to be out of time. Also significant wear on the upper portion of rack will result if gear and rack are not tight.

Significant wear on wear strips can cause gear rack clearance to be too great. If wear is the issue, replace and then check the measurement.

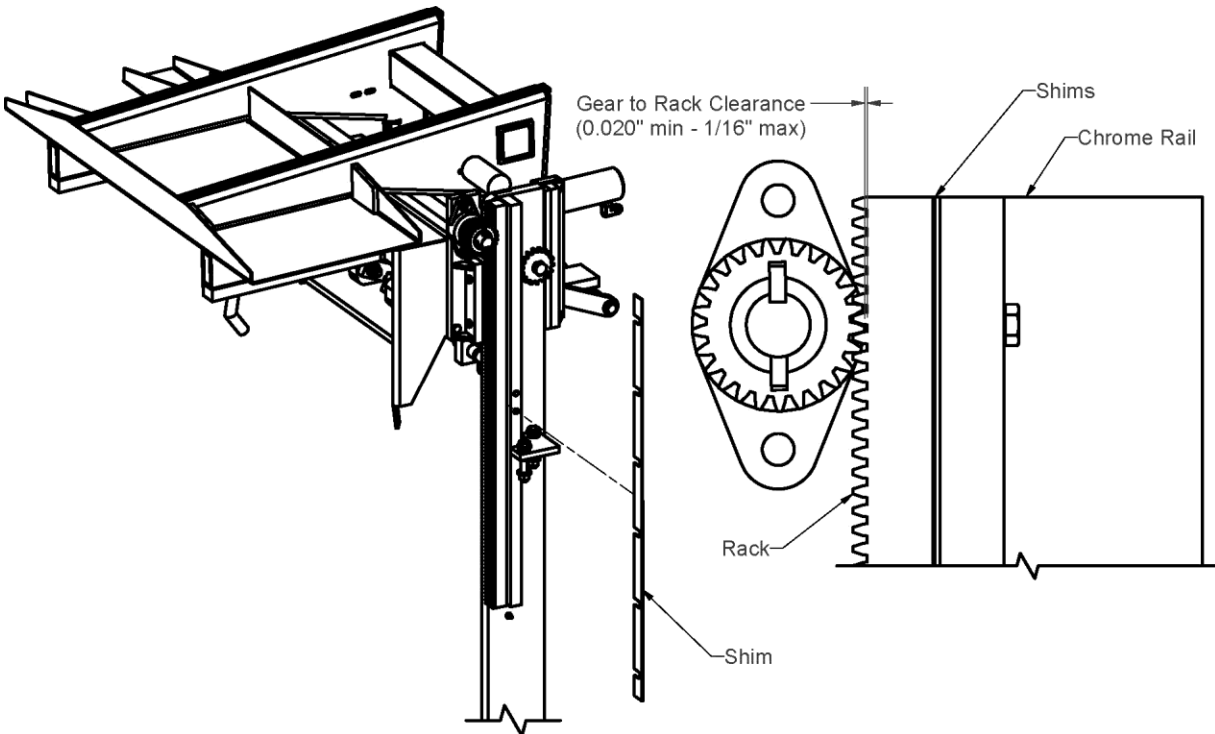

If the wear strips are not the cause of the large gear rack clearance then shimming the rack out to the gear will be a final fix. Space rack out from vertical plunger to achieve desired dimension.

- Shim 1-M-0146 is 14 ga (0.074 inch) (1.88 mm)
- Shim 1-M-0147 is 20 ga (0.0375 inch) (0.95 mm)
- These shims allow you to loosen the rack bolts and slide them in from the side.

How to put the vertical plunger “in time” if is “out of time.”

- Put the vertical plunger in top position. (Cylinder extended)
- Count the teeth on rack down to where the teeth on gear mesh with rack, and then count teeth on other rack to corresponding teeth on gear. Both sides should be the same for proper “timing.”

Hydraulic Manifold Layout

Front Manifold

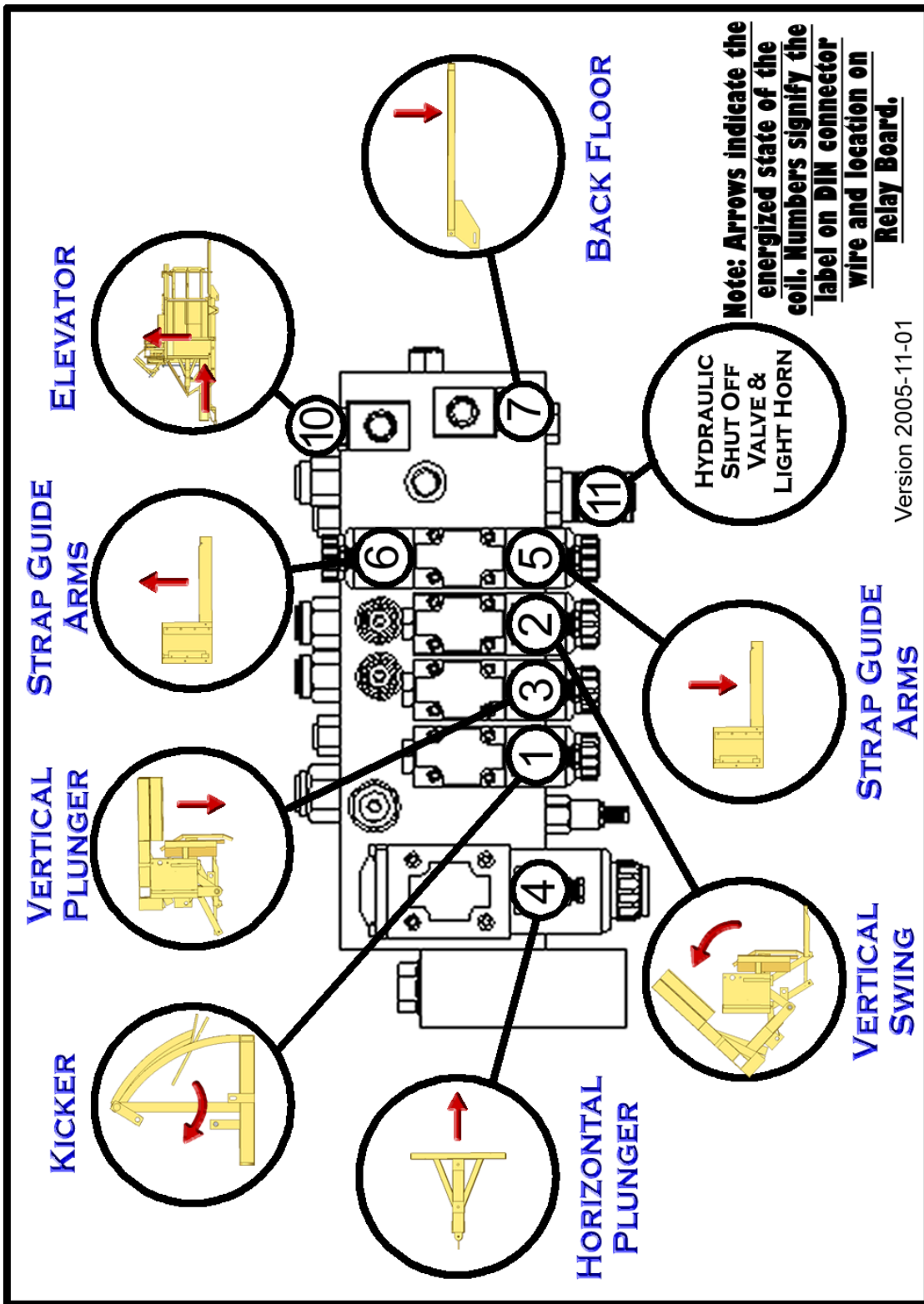

Version 2005-11-01

Inside Banding Box Manifold

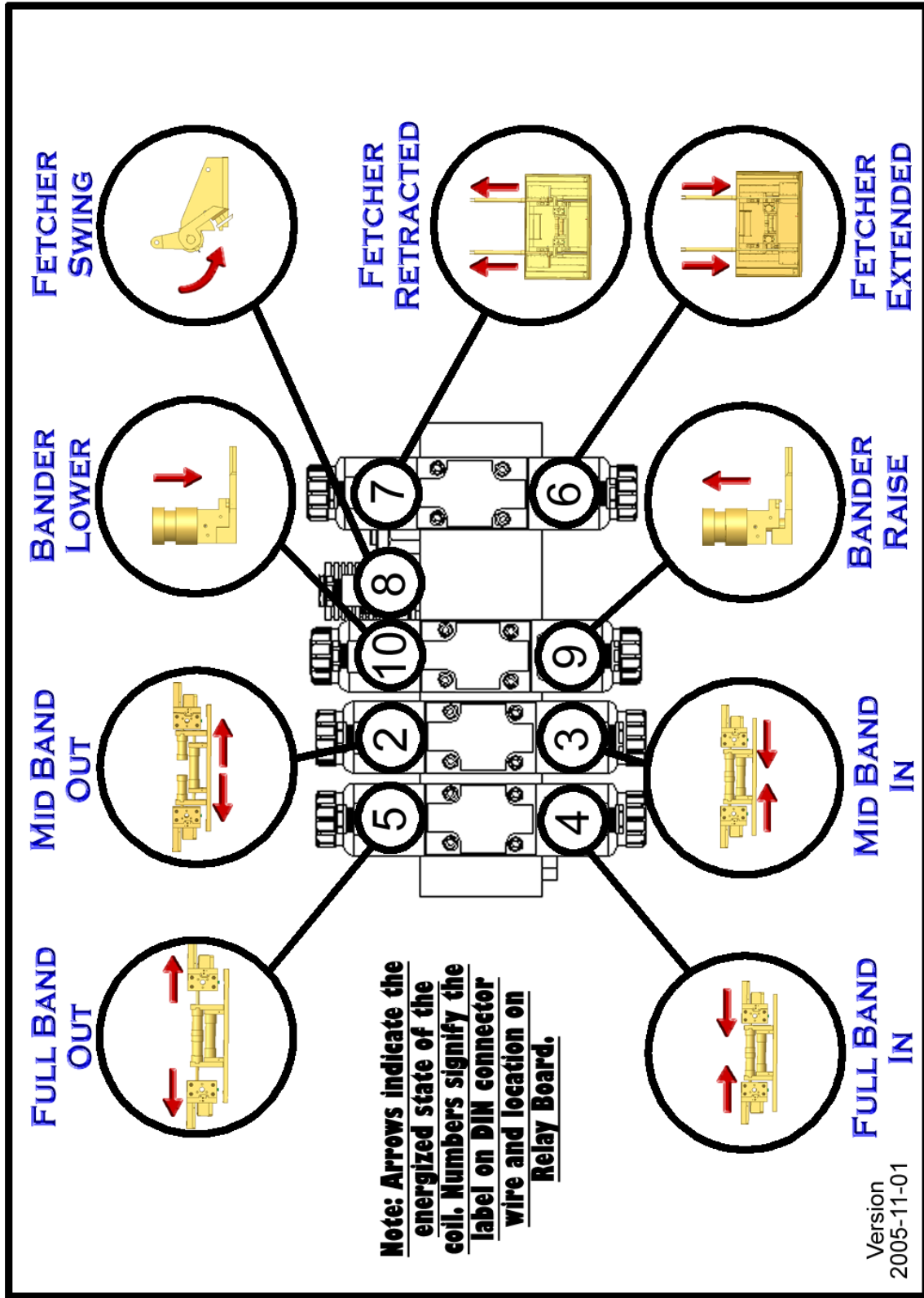

Outside Banding Box Manifold

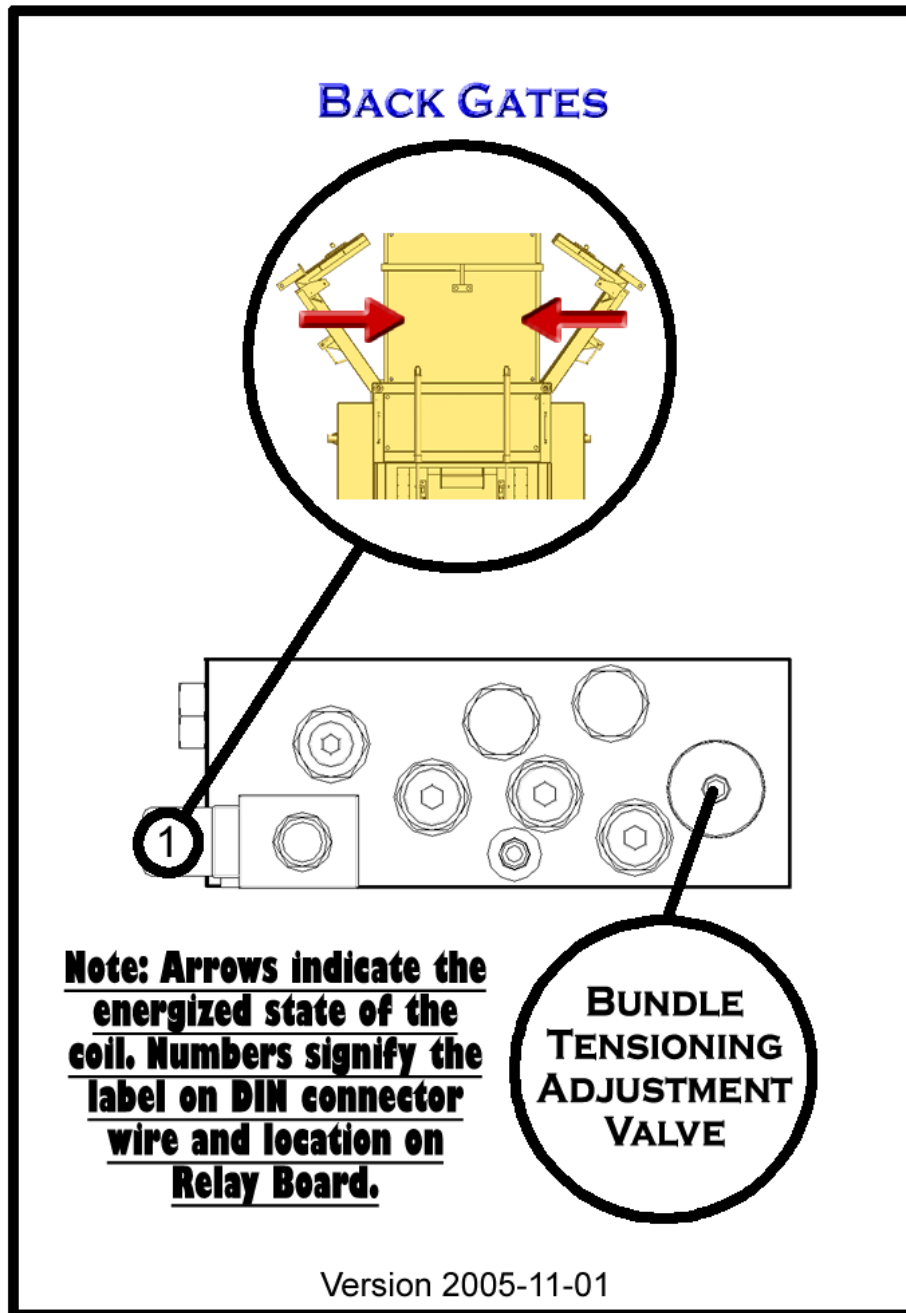

Electrical Layout

Front Relay Box (located behind banding drums)

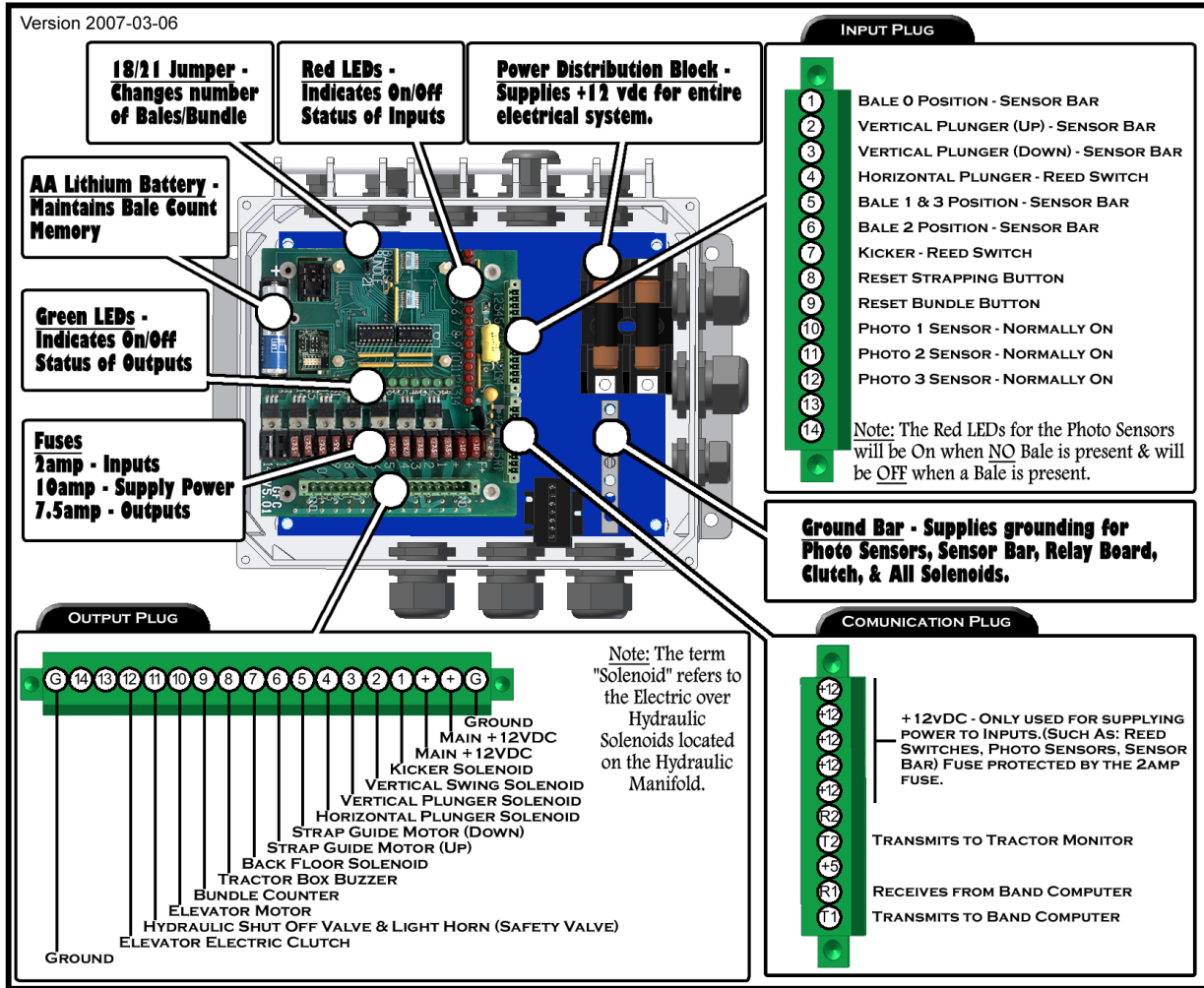

Band Relay Box (located in Banding Box)

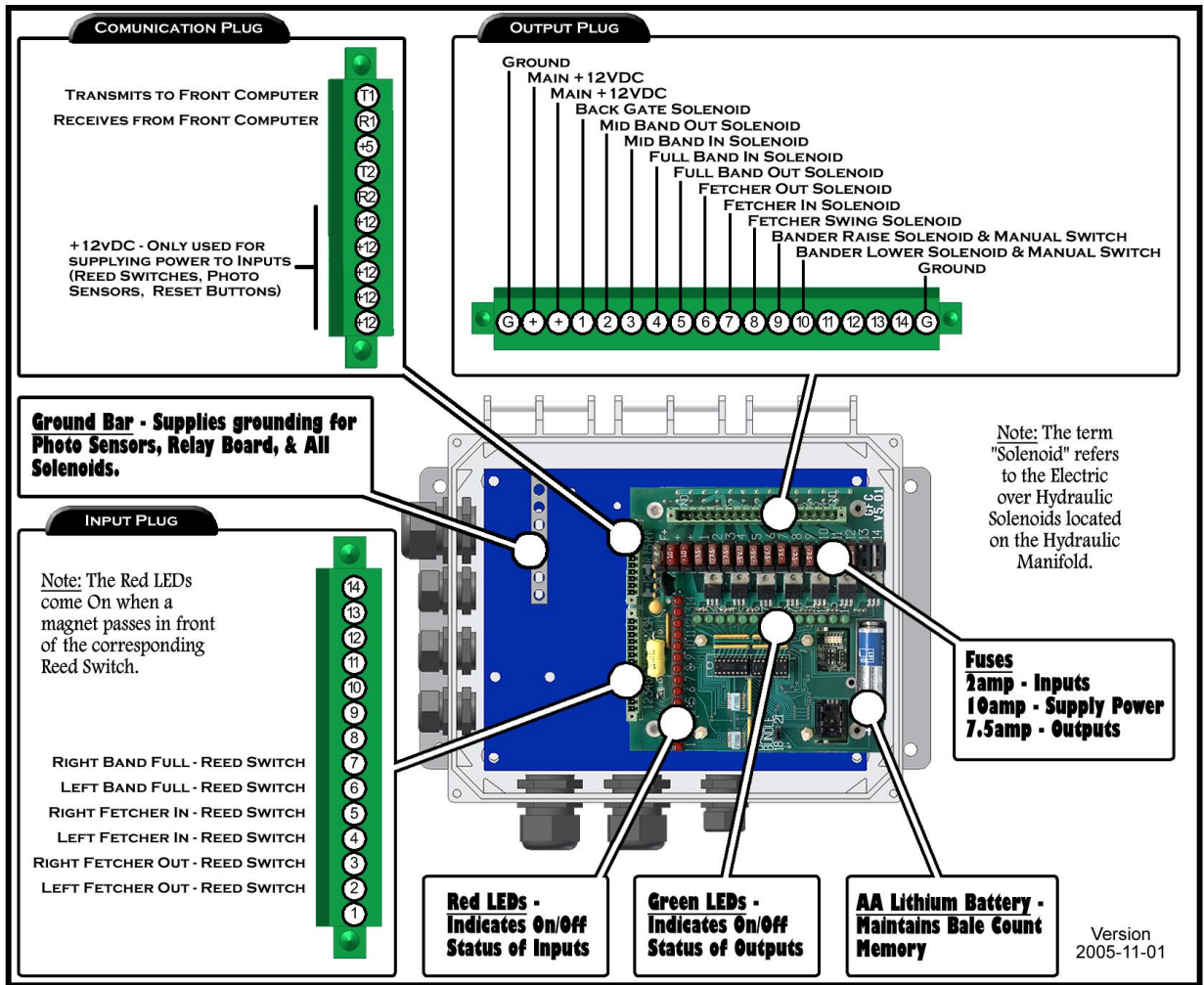

Relay Board

(Version Date 05/08/01)

Front Computer Relay Board

Input#	Red LEDs		Output#	Green LEDs
1	bale 0		1	kicker
2	vertical swing		2	vertical swing
3	vertical plunger		3	vertical plunger
4	horizontal plunger		4	horizontal plunger, (green wire for manuel)
5	bale1 & bale 3		5	strap guide motor down
6	bale2		6	strap guide motor up
7	kicker (black #5 wire)		7	back floor, (white wire for manuel)
8	reset banding (black #6 wire)		8	strap out
9	reset bundle (green wire)		9	counter
10	photo1		10	elevator
11	photo2 (black #3 wire)		11	safety valve
12	photo3 (black #4 wire)		12	clutch

Banding Box Computer Relay Board

Input#	Red LEDs		Output#	Green LEDs
1	OPEN		1	back gate
2	left fetcher out		2	mid band out
3	right fetcher out		3	mid band in
4	left fetcher in		4	full band in
5	right fetcher in		5	full band out
6	left band full		6	fetcher out
7	right band full		7	fetcher in
8			8	fetcher swing
9			9	bander raise, (blue wire for manuel)
10			10	bander lower, (yellow wire for manuel)
11			11	
12			12	

The above spreadsheet indicates the location of each input and output on the relay boards. There are two computers/relay boards on the machine. One computer/relay board is located in the Front Relay box on the front of the machine. The other computer/relay board is located in the Band Relay box inside of the Banding box. The computer/relay boards and software are identical and therefore are interchangeable.

Program Options:

There are two program options available on the machine. The 18 bales/bundle option is intended for the 16 inches x 18 inches small square bales. This program will bundle together 18 bales. The 21 bales/bundle option is intended for the 14 inches x 18 inches small square bales. This program will bundle together 21 bales. In order to switch programs, first unplug the main power cord, move the jumper to the desired program option. Plug the main power cord back together. The Tractor Display will then indicate which option has been activated as soon as power has been applied.

RED LEDs

When a red LED is on this indicates that that specific input is on. For example, if red LED #7 is on, then the Kicker read switch has a magnet in front of it. The Photo eye LEDs work a little different. The red LED inputs# 10, 11, 12 will be on when NO bale is present, but the yellow LED located on the Photo eye itself will be off. And when a bale IS present, the red LED (in the box) will go off and the yellow LED on the Photo eye will come on.

GREEN LEDs

When a green LED is on this indicates that that specific output is on. For example, if green LED #2 is on, then the Vertical Swing is in the “Energized State” (Vertical Swing Cylinder is Extended, see “Hydraulic Manifold Layout”)

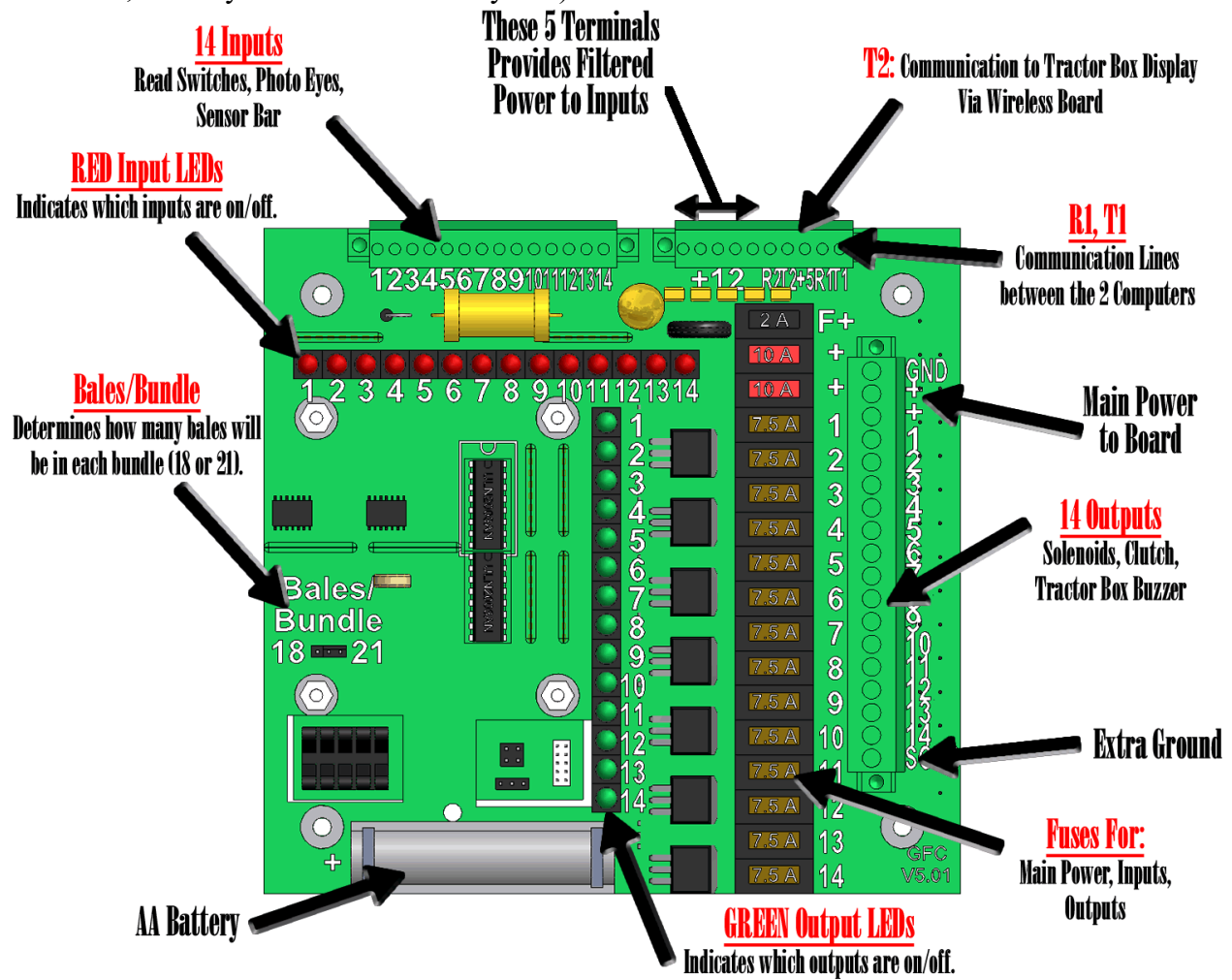

Fuse Rating			
Amp	Description	Amp	Description
2	Power to Inputs (+12 terminals)	7.5	Output 7
10	Main Power	7.5	Output 8
10	Main Power	7.5	Output 9
7.5	Output 1	7.5	Output 10
7.5	Output 2	7.5	Output 11
7.5	Output 3	7.5	Output 12
7.5	Output 4	7.5	Output 13
7.5	Output 5	7.5	Output 14
7.5	Output 6		

Display Monitor Troubleshooting Solutions

- Lines 1&2: Error code description
- Line 3: Three digit error code. And communication status (one digit located after the dash).
- Line 4: Number of bales in the current bundle & approx. amount of strapping remaining on Banding Drums

Other Display Monitor Functions:

- **‘Out of Strapping’ displayed with buzzer:** This occurs after 122 bundles have been banded. When the display shows ‘Out of Strapping’ and the buzzer is on, the Reset Strapping button must be pressed in order for the Bale Band-It to continue. Once this has been done the computer resets its strapping counter to 122.

If the operator determines there is still enough strapping remaining to do more bundles, press the Reset Strapping button and continue baling without reloading strapping. But then operator must visually keep a close watch on the amount of strapping to prevent the possibility of running out. Anytime two new rolls of strapping have been put onto the machine the Reset Strapping button must be pressed in order for Bale Band-It to keep an accurate Strapping count.

- **Busted Bale:** The Bale Band-It can help notify the operator of a possible busted bale from the baler. If a bale does not move through the elevator process in a timely fashion the Display Monitor will indicate to the operator by beeping twice. This does not remove the responsibility from the operator to watch for untied bales, but it does provide a help.
- **Foreign object blocking Photo Eye #3:** Before the elevator moves the bale from Photo Eye #2 position to Photo Eye #3 position, the software does a safety check on Photo Eye #3. If any hay chaff or debris is detected a Photo Eye #3 the elevator process will stop the bale at Photo Eye #2 and the monitor buzzer will be activated. To continue, the operator must disengage the tractor’s hydraulic power supply (turn off the hydraulic remote) to the machine. Then unplug the main electrical power cord to the machine, remove the hay chaff or debris from Photo Eye #3, plug the main electrical power cord back together, re-engage hydraulic power supply and the machine will continue operation.



LCD Display Information:

The LCD is very informative and provides the operator with troubleshooting information. Approximately every 5 seconds the LCD is updated to the current status of the unit. As stated above, *Lines 1& 2* go hand in hand with *Line 3*. The first two lines give a short description of what *Line 3* gives in error code form. The detailed description of the first three digits on *Line 3* can be found in the following pages. The following pages also give different scenarios to further help in any troubleshooting instances.

Before inspecting the machine, turn off hydraulic power supply by disengaging the tractor’s hydraulic remote and shutting off tractor. *Line 3* on the Display Monitor indicates what the computer is looking for before the next process can occur.

Line 3 also indicates the communication status between the two computers on the Bale Band-It. This information is found after the dash on *Line 3*. This one digit number will be either 1 or 0. 1 means communication is okay, 0 means communication is down or delayed.



Error Code Possible Solutions

001 Reset Bundle button is stuck on.

- Press Reset Bundle Button a few times to un-stick it.
- Tap on the side of button.
- Take Reset Bundle Button apart internally and clean out hay dust

002 Reset Strapping button is stuck on.

- Press Reset Strapping Button a few times to un-stick it.
- Tap on the side of button.
- Take Reset Strapping Button apart internally and clean out hay dust

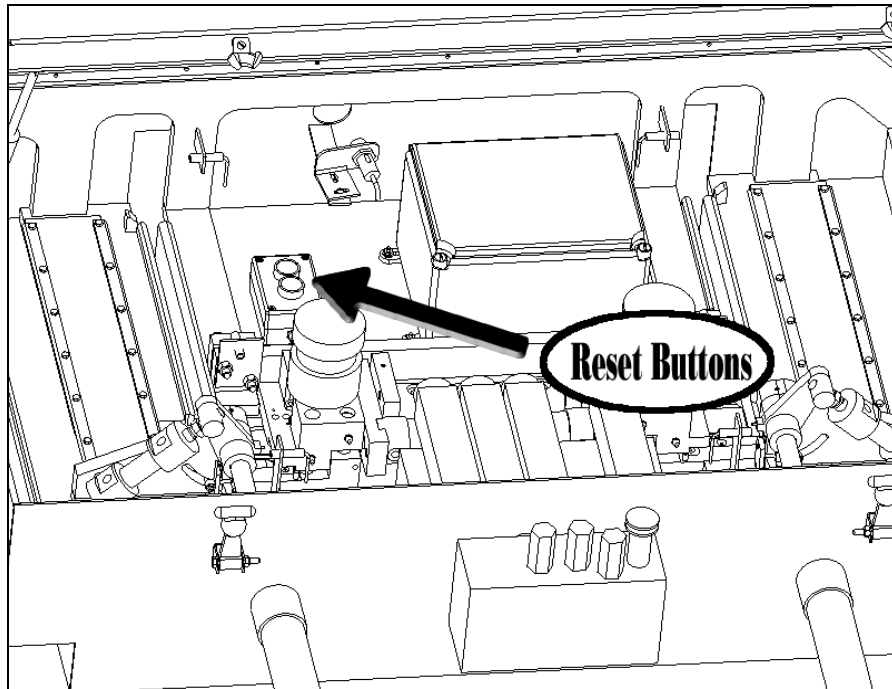

003 Waiting for Kicker reed switch to be off.

Note: Before the machine extends the Kicker cylinder, the Kicker reed switch is in front of the first magnet mounted in the round plastic. When the machine extends the Kicker cylinder it rotates the round plastic, moving the first magnet away from the switch, which turns the Kicker reed switch off. This is what the machine is waiting for.

If the Kicker cylinder is fully extended,

- Loosen nuts on Kicker reed switch and hold the switch away from any magnets or metal for approximately 10 seconds. Check tractor box display to see if it is still displays “003”. If it does, lightly tap the switch on something to free up the stuck switch. The switch may need to be replaced if this problem continues.

If the Kicker cylinder is partially extended,

- Check that a bale or foreign object is not preventing the Kicker from extending.
- Hydraulic power or hydraulic return has been disconnected or shut off from machine. This circuit has a 2-position valve and cannot be partially extended unless hydraulic power or return has been disconnected or shut off.

If the Kicker cylinder is still retracted,

- Check that hydraulic power is still on to the machine and that return line is still connected.
- Check that a bale or foreign object is not preventing the Kicker from extending.
- Check that the directional valve is not stuck.

004 Waiting for Kicker reed switch to be on.

Note: After the machine has extended the Kicker cylinder, the Kicker reed switch should be lined up with the magnet mounded in the round plastic, which turns the switch on. This is what the machine is waiting for.

If the Kicker cylinder is fully extended,

- Check the air gap distance between the Kicker reed switch and the magnet. The distance should be a maximum of 3/8 inch (9 mm). If it is within the suggested range then the reed switch needs to be replaced.

If the Kicker cylinder is partially extended,

- Check that a bale or foreign object is not preventing the Kicker from extending.
- Hydraulic power or hydraulic return has been disconnected or shut off from machine. This circuit has a 2-position valve and cannot be partially extended unless power or return has been disconnected or shut off.

If the Kicker cylinder is still retracted,

- Check that hydraulic power is still on to the machine and that return line is still connected.
- Check that a bale or foreign object is not preventing the Kicker from extending.
- Check that the directional valve is not stuck.

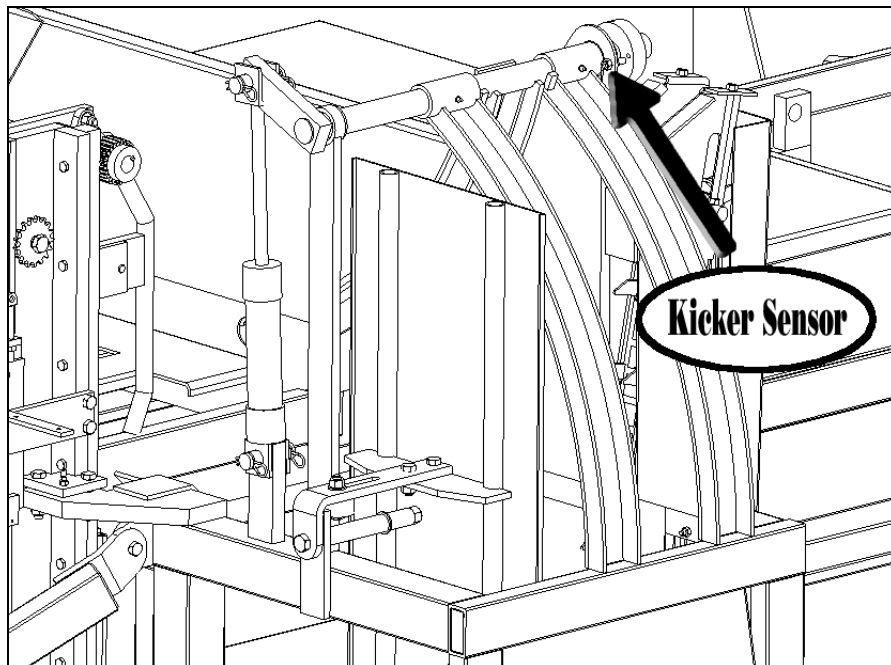

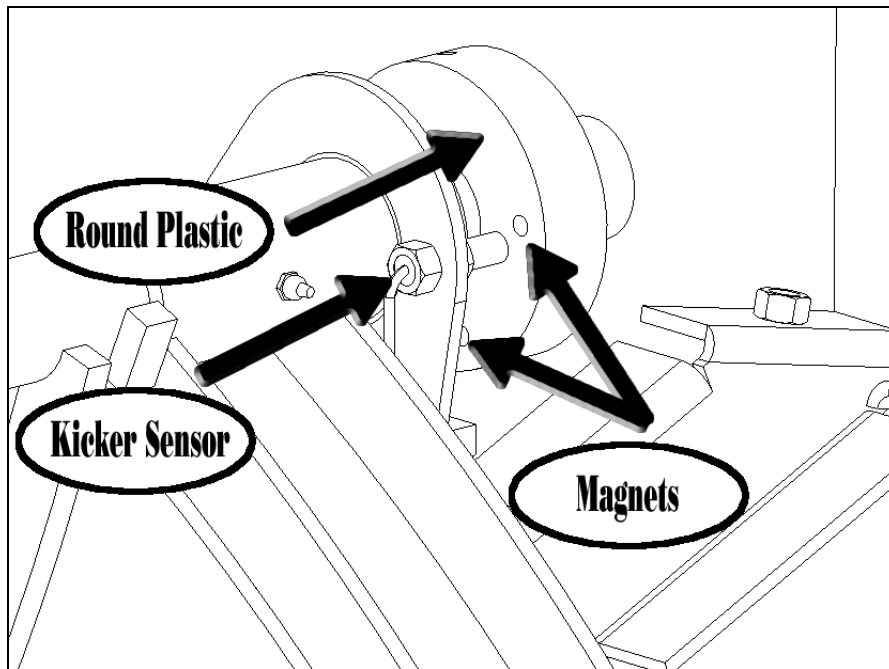

005 Timer Delay Error

- Disengage hydraulic power and unplug main power cord. Wait for approximately 10 seconds, plug back in and engage hydraulic power.

006 Waiting for Horizontal Plunger reed switch to be off.

Note: Before the machine retracts the Horizontal Plunger cylinder, the Horizontal Plunger reed switch is in front of the first set of magnets. When the machine retracts the Horizontal Plunger cylinder it moves the first magnet away from the switch, which turns the Horizontal Plunger reed switch off. This is what the machine is waiting for.

If the Horizontal Plunger cylinder is fully retracted,

- Loosen nuts on Horizontal Plunger reed switch and hold the switch away from any magnets or metal for approximately 10 seconds. Check tractor box display to see if it still displays "006". If it does, lightly tap the switch on something to free up the stuck switch. The switch may need to be replaced if this problem continues.

If the Horizontal Plunger cylinder is partially retracted,

- Check that a bale or foreign object is not preventing the Horizontal Plunger from retracting.
- Hydraulic power or hydraulic return has been disconnected or shut off from machine. This circuit has a 2-position valve and cannot be partially extended unless power or return has been disconnected or shut off.

If the Horizontal Plunger cylinder is still extended,

- Check that hydraulic power is still on to the machine and that return line is still connected.
- Check that a bale or foreign object is not preventing the Horizontal Plunger from retracting.
- Check that the directional valve is not stuck.

007 Waiting for Horizontal Plunger reed switch to be on.

Note: After the machine has retracted the Horizontal Plunger cylinder, the Horizontal Plunger reed switch should be lined up with a set of magnets, which turns the switch on. This is what the machine is waiting for.

If the Horizontal Plunger cylinder is fully retracted,

- Check the air gap distance between the Horizontal Plunger reed switch and the magnet. The distance should be a maximum of 3/8 inch (9 mm). If it is within the suggested range then the reed switch needs to be replaced.

If the Horizontal Plunger cylinder is partially retracted,

- Check that a bale or foreign object is not preventing the Vertical Plunger cylinder from retracting.
- Hydraulic power or hydraulic return has been disconnected or shut off from machine. This circuit has a 2-position valve and cannot be partially extended unless power or return has been disconnected or shut off.

If the Horizontal Plunger cylinder is still extended,

- Check that hydraulic power is still on to the machine and that return line is still connected.
- Check that a bale or foreign object is not preventing the Horizontal Plunger cylinder from retracting.
- Check that the directional valve is not stuck.

008 Timer Delay Error

- Disengage hydraulic power and unplug main power cord. Wait for approximately 10 seconds, plug back in and engage hydraulic power.

009 Waiting for Horizontal Plunger reed switch to be on.

Note: After the machine has retracted the Horizontal Plunger cylinder, the Horizontal Plunger reed switch should be lined up with a set of magnets, which turns the switch on. This is what the machine is waiting for.

If the Horizontal Plunger cylinder is fully retracted,

- Check the air gap distance between the Horizontal Plunger reed switch and the magnet. The distance should be a maximum of 3/8 inch (9 mm). If it is within the suggested range then the reed switch needs to be replaced.

If the Horizontal Plunger cylinder is partially retracted,

- Check that a bale or foreign object is not preventing the Vertical Plunger cylinder from retracting.
- Hydraulic power or hydraulic return has been disconnected or shut off from machine. This circuit has a 2-position valve and cannot be partially extended unless power or return has been disconnected or shut off.

If the Horizontal Plunger cylinder is still extended,

- Check that hydraulic power is still on to the machine and that return line is still connected.
- Check that a bale or foreign object is not preventing the Horizontal Plunger cylinder from retracting.
- Check that the directional valve is not stuck.

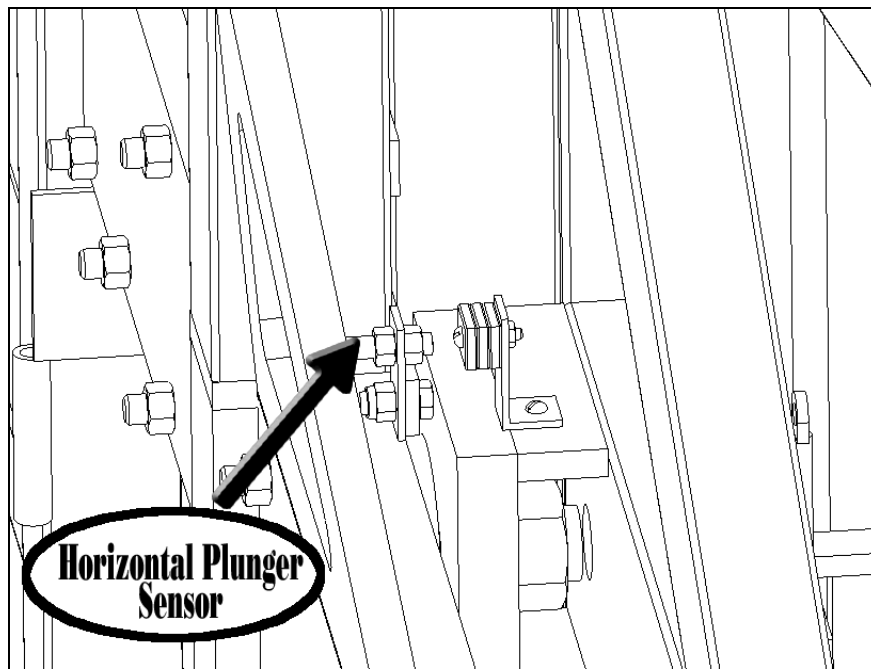
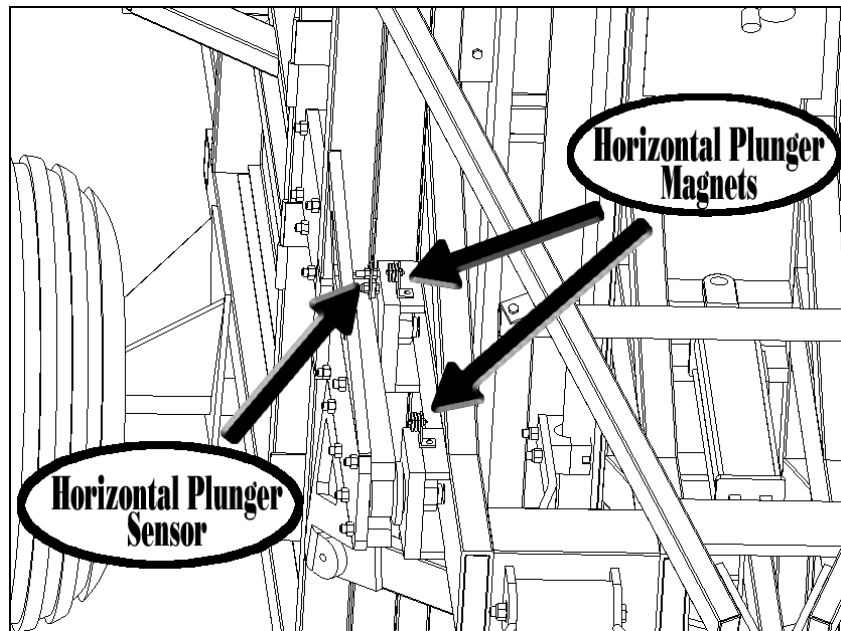

010 Vertical Plunger Up sensor bar switch is stuck on.

Note: Before the machine retracts the Vertical Plunger Swing cylinder it does a safety check on the Vertical Plunger Up sensor bar switch. It checks to see if the sensor bar switch is stuck on. If it is, it will wait until the sensor bar switch is off before continuing the operation. The switch is located at the top of the sensor bar at the white mark.

If Vertical Plunger Swing cylinder is retracted,

- Check that hydraulic power is still on to the machine and that return line is still connected.
- Check that a bale or foreign object is not preventing the Vertical Plunger Swing cylinder from extending.
- Check that the directional valve is not stuck.

If Vertical Plunger Swing cylinder is fully extended,

- Tap on Vertical Plunger Swing sensor bar switch until display number changes or replace the sensor bar.

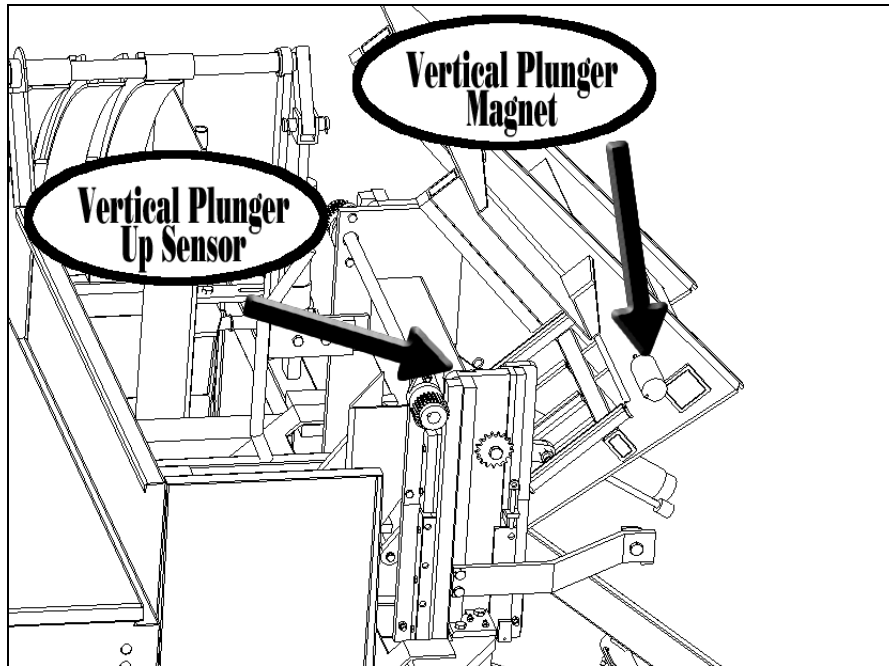

011 Waiting for Vertical Plunger Up sensor bar switch to be on.

Note: After the machine has retracted the Vertical Plunger Swing cylinder, the Vertical Plunger Up magnet should be lined up with the Vertical Plunger sensor bar switch, which turns the switch on. This is what the machine is waiting for. The switch is located at the top of the sensor bar at the white mark.

If the Vertical Plunger Swing cylinder is fully retracted,

- Check the air gap distance between the Vertical Plunger Up sensor bar switch and the magnet. The distance should be a maximum of 3/8 inch (9mm). If it is within the suggested range then the sensor bar needs to be replaced.

If the Vertical Plunger Swing cylinder is partially retracted,

- Check that a bale or foreign object is not preventing the Vertical Plunger Swing cylinder from retracting.
- Hydraulic power or hydraulic return has been disconnected or shut off from machine. This circuit has a 2-position valve and cannot be partially extended unless power or return has been disconnected or shut off.

If the Vertical Plunger Swing cylinder is still extended,

- Check that hydraulic power is still on to the machine and that return line is still connected.
- Check that a bale or foreign object is not preventing the Vertical Plunger Swing cylinder from retracting.
- Check that the directional valve is not stuck.

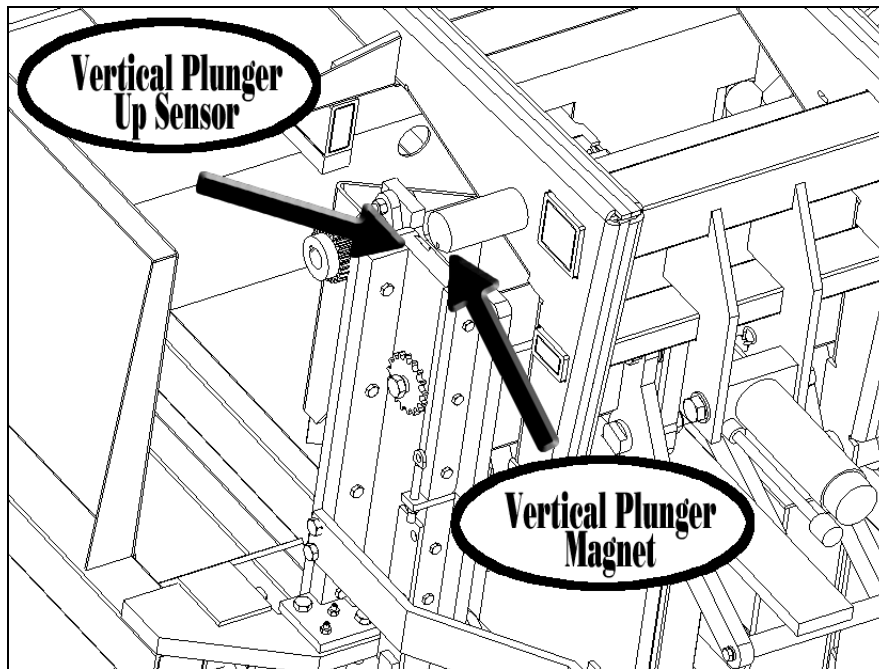

012 Timer Delay Error

- Disengage hydraulic power and unplug main power cord. Wait for approximately 10 seconds, plug back in and engage hydraulic power.

013 Waiting for Strap Guide Arms at Bale Position 1.

Note: The machine has turned on the Strap Guide Arms motor and sent them down. When the Strap Guide Arms magnet reaches the Bale Position 1 sensor bar switch, the machine stops the motor. The machine is waiting for the magnet to reach the Bale Position 1 sensor bar switch. The switch is located mid way down the sensor bar at the green mark.

Check position of Strap Guide Arms.

If Strap Guide Arms are on the floor,

- Check how the return line is hooked to the tractor and make sure there is NO BACKPRESSURE. If there is any backpressure at all the Bale Band-It will not operate properly and will continue to release the Strap Guide Arms motor's brake causing improper location of Strap Guide Arms. Backpressure is the #1 problem with the Strap Guide Arms not being in the proper position. The return line CANNOT be connected directly to the remote or ran through a return kit. It must be connected directly to the tank of the tractor or through the fill cap WITHOUT restriction.
- Disengage hydraulic power and place a magnet (South Pole only) in front of the Bale Position 1 sensor bar switch for 2 seconds and check to see if tractor display has changed. This switch within the sensor bar is located approximately 5 inches (127 mm) down from the bottom of the Vertical Plunger plate and will be marked with a green colored pen. Since the Strap Guide Arms are currently on the floor, after each of the next 2 bales are placed into the machine error codes 014 & 015 will be displayed because the Strap Guide Arms are not in the correct position to activate the corresponding sensor bar switches. When error codes 014 & 015 appear follow the instructions for that specific error.

If the Strap Guide Arms are not on the floor,

- Check that the tension applied by the Strap Crimper Roller is not too great. If the strapping is too thick or foreign material is located in the Strap Crimper Roller it will

cause excessive strap tension. If the tension is too great it will stall the Strap Guide Motor.

- Check that the strapping is not caught or kinked preventing it from flowing easily.
- Check that hydraulic power is still on to the machine and that return line is still connected.
- Check that a bale or foreign object is not preventing the Strap Guide Arms from moving.
- Check that the directional valve is not stuck.

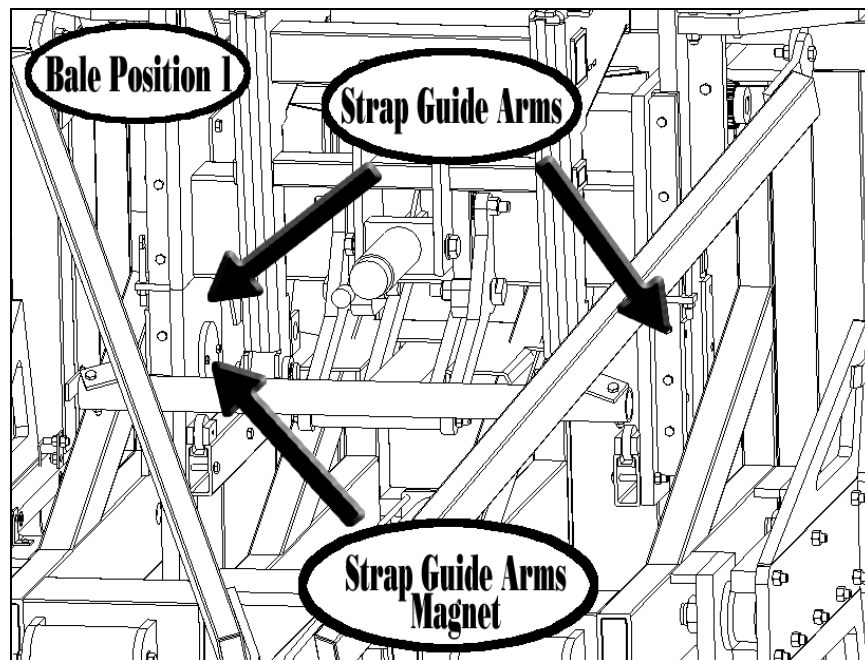
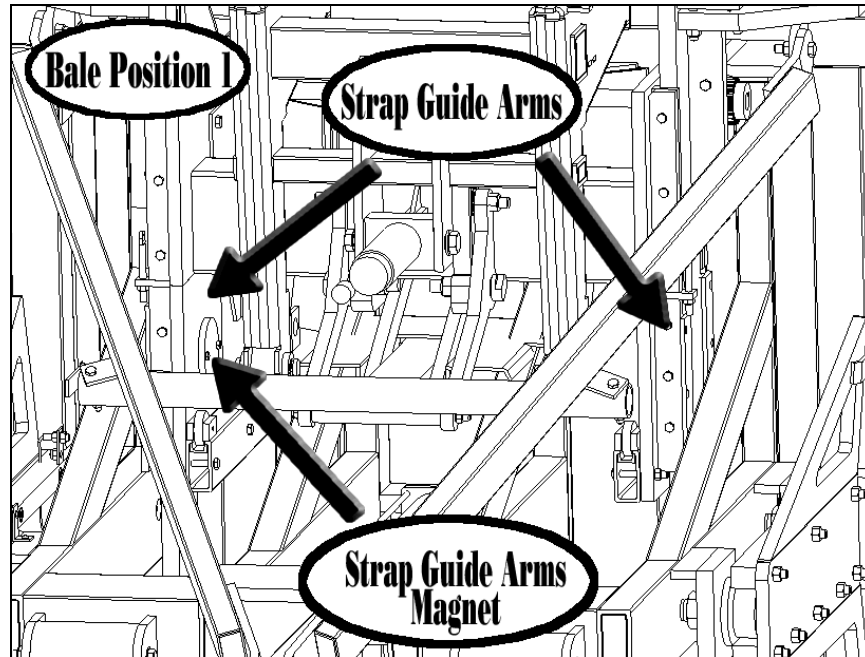

014 Waiting for Strap Guide Arms at Bale Position 2.

Note: The machine has turned on the Strap Guide Arms motor and sent them down. When the Strap Guide Arms magnet reaches the Bale Position 2 sensor bar switch, the machine stops the motor. The machine is waiting for the magnet to reach the Bale

Position 2 sensor bar switch. The switch is located mid way down the sensor bar at the blue mark.

Check position of Strap Guide Arms.

If Strap Guide Arms are on the floor,

- Check how the return line is hooked to the tractor and make sure there is NO BACKPRESSURE. If there is any backpressure at all the Bale Band-It will not operate properly and will continue to release the Strap Guide Arms motor's brake causing improper location of Strap Guide Arms. Backpressure is the #1 problem with the Strap Guide Arms not being in the proper position. The return line CANNOT be connected directly to the remote or ran through a return kit. It must be connected directly to the tank of the tractor or through the fill cap WITHOUT restriction.
- Disengage hydraulic power and place a magnet (South Pole only) in front of the Bale Position 2 sensor bar switch for 2 seconds and check to see if tractor display has changed. This switch within the sensor bar is located approximately 23 inches (584 mm) down from the bottom of the Vertical Plunger plate and will be marked with a blue colored pen. Since the Strap Guide Arms are currently on the floor, after the next bales is placed into the machine error code 015 may be displayed because the Strap Guide Arms are not in the correct position to activate the corresponding sensor bar switches. When error code 015 appears follow the instructions for that specific error.

If the Strap Guide Arms are not on the floor,

- Check that the tension applied by the Strap Crimper Roller is not too great. If the strapping is too thick or foreign material is located in the Strap Crimper Roller it will cause excessive strap tension. If the tension is too great it will stall the Strap Guide Motor.
- Check that the strapping is not caught or kinked preventing it from flowing easily.
- Check that hydraulic power is still on to the machine and that return line is still connected.
- Check that a bale or foreign object is not preventing the Strap Guide Motor from moving.
- Check that the directional valve is not stuck.

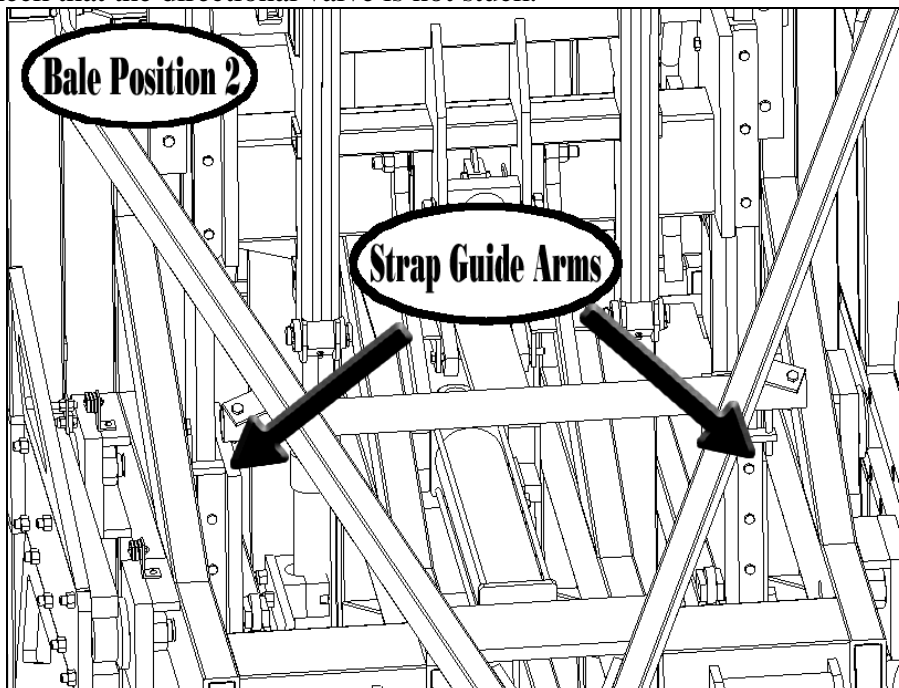

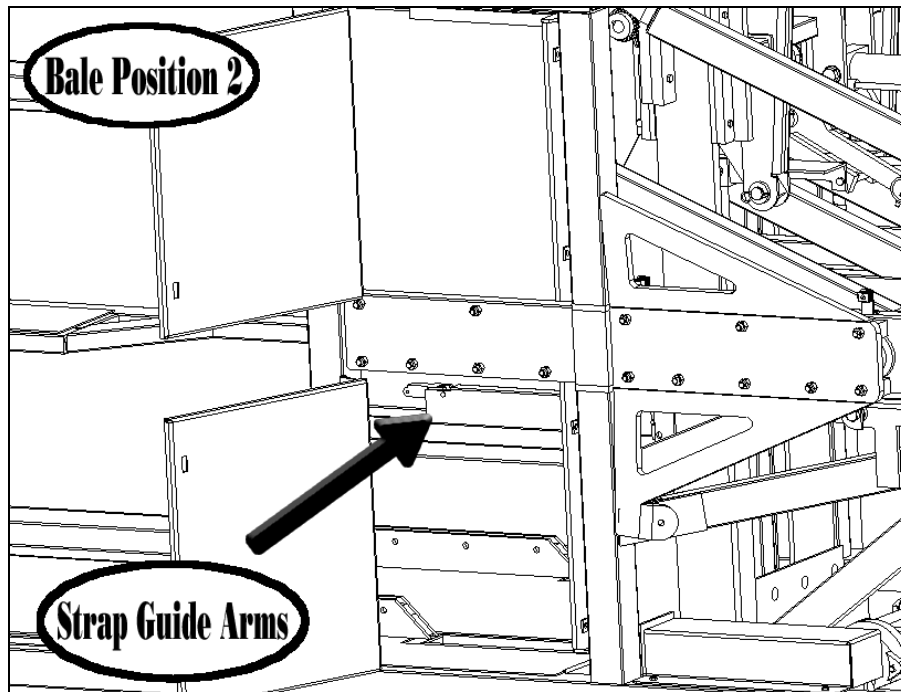

015 Waiting for Strap Guide Arms at Bale Position 3.

Note: The machine has turned on the Strap Guide Arms motor and sent them down. When the Strap Guide Arms magnet reaches the Bale Position 3 sensor bar switch, the machine stops the motor. The machine is waiting for the magnet to reach the Bale Position 3 sensor bar switch. The switch is located near the bottom of the sensor bar at the yellow mark.

Check position of Strap Guide Arms.

If Strap Guide Arms are on the floor,

- Check how the return line is hooked to the tractor and make sure there is NO BACKPRESSURE. If there is any backpressure at all the Bale Band-It will not operate properly and will continue to release the Strap Guide Arms motor's brake causing improper location of Strap Guide Arms. Backpressure is the #1 problem with the Strap Guide Arms not being in the proper position. The return line CANNOT be connected directly to the remote or ran through a return kit. It must be connected directly to the tank of the tractor or through the fill cap WITHOUT restriction.
- Check for excess hay or chaff under the Strap Guide Arms preventing them from going down. Chaff will periodically build up here according to the different conditions of the hay. The dryer the hay, the more chaff builds up. It is a good operating practice to periodically clean the area under the Strap Guide Arms to prevent this. When this happens disengage hydraulic power and place a magnet (South Pole only) in front of the Bale Position 3 sensor bar switch for 2 seconds. This switch within the sensor bar is located near the bottom of the sensor bar and will be marked with a yellow colored pen. Due to the Strap Guide Arms being in the bottom position, this switch is not easily accessed. To provide an easier way, the Bale Position 1 and Bale Position 3 switches are wiring together. Therefore, placing the south pole of the magnet at Bale Position 1 (green mark) will trip the switch at Bale Position 3. Engage hydraulic power, the machine should continue to operate, raising the Strap Guide Arms to the top of the machine. This will allow for easy removal of the chaff and excess hay from under the Strap Guide Arms.
- Check that Strap Guide Arms are in time with each other. They should be the same height. If their heights vary 1/2 inch (12.5 mm) or greater then they are at least one gear

tooth out of time. A quick way to check their heights is to compare the distance between the Vertical Plunger plates to the Strap Guide plates. In order to prevent the Strap Guide arms from getting out of time, keep their chains tight.

If the Strap Guide Arms are not on the floor,

- Check that the tension applied by the Strap Crimper Roller is not too great. If the strapping is too thick or foreign material is located in the Strap Crimper Roller it will cause excessive strap tension. If the tension is too great it will stall the Strap Guide Motor.
- Check that the strapping is not caught or kinked preventing it from flowing easily.
- Check that hydraulic power is still on to the machine and that return line is still connected.
- Check that a bale or foreign object is not preventing the Strap Guide Motor from moving.
- Check that the directional valve is not stuck.

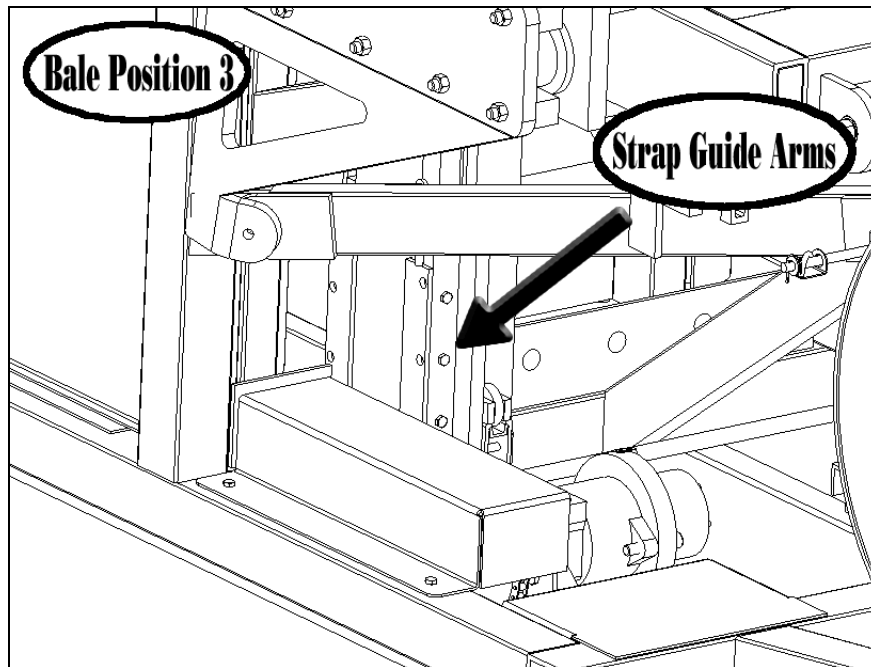

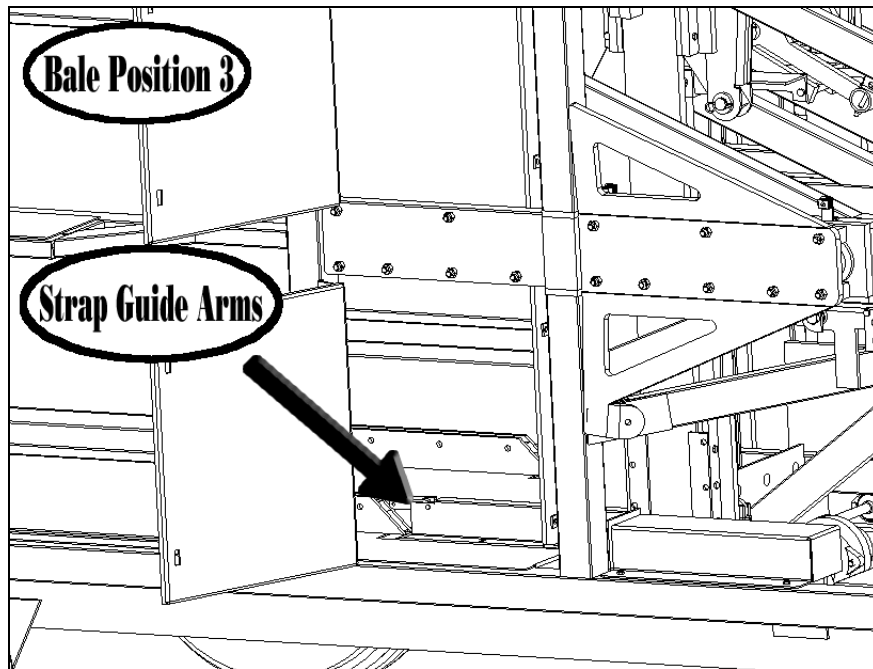

016 Computer Error

- Disengage hydraulic power and unplug main power cord. Wait for approximately 10 seconds, plug back in and engage hydraulic power. If this doesn't change the "098" code, then take out all bales in front chamber by opening the side doors. Once the bales are out, press the Reset Bundle button.

017 Waiting for Vertical Plunger Down sensor bar switch to be on.

Note: After the machine has retracted the Vertical Plunger cylinder, the Vertical Plunger Down magnet should be lined up with the Vertical Plunger sensor bar switch, which turns the switch on. This is what the machine is waiting for. The switch is located mid way of the sensor bar at the red mark.

If the Vertical Plunger cylinder is fully retracted,

- Check the air gap distance between the Vertical Plunger reed switch and the magnet. The distance should be a maximum of 3/8 inch (9 mm). If it is within the suggested range then the sensor bar needs to be replaced.

If the Vertical Plunger cylinder is partially retracted,

- Check that a bale or foreign object is not preventing the Vertical Plunger cylinder from retracting.
- Hydraulic power or hydraulic return has been disconnected or shut off from machine. This circuit has a 2-position valve and cannot be partially extended unless power or return has been disconnected or shut off.

If the Vertical Plunger cylinder is still extended,

- Check that hydraulic power is still on to the machine and that return line is still connected.
- Check that a bale or foreign object is not preventing the Vertical Plunger cylinder from retracting.
- Check that the directional valve is not stuck.

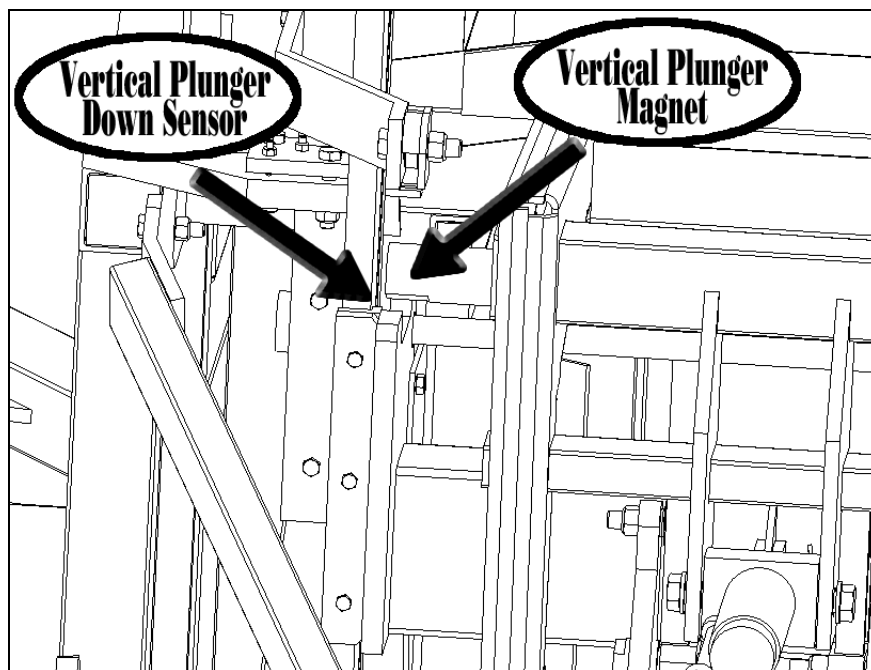

018 Waiting for Kicker reed switch to be off.

Note: Before the machine retracts the Kicker cylinder, the Kicker reed switch is in front of the first magnet mounted in the round plastic. When the machine retracts the Kicker cylinder it rotates the round plastic, moving the first magnet away from the switch, which turns the Kicker reed switch off. This is what the machine is waiting for.

If the Kicker cylinder is fully retracted,

- Loosen nuts on Kicker reed switch and hold the switch away from any magnets or metal for approximately 10 seconds. Check tractor box display to see if it is still displays “018”. If it does, lightly tap the switch on something to free up the stuck switch. The switch may need to be replaced if this problem continues.

If the Kicker cylinder is partially retracted,

- Check that a bale or foreign object is not preventing the Kicker from retracting.
- Hydraulic power or hydraulic return has been disconnected or shut off from machine. This circuit has a 2-position valve and cannot be partially extended unless power or return has been disconnected or shut off.

If the Kicker cylinder is still extended,

- Check that hydraulic power is still on to the machine and that return line is still connected.
- Check that a bale or foreign object is not preventing the Kicker from retracting.
- Check that the directional valve is not stuck.

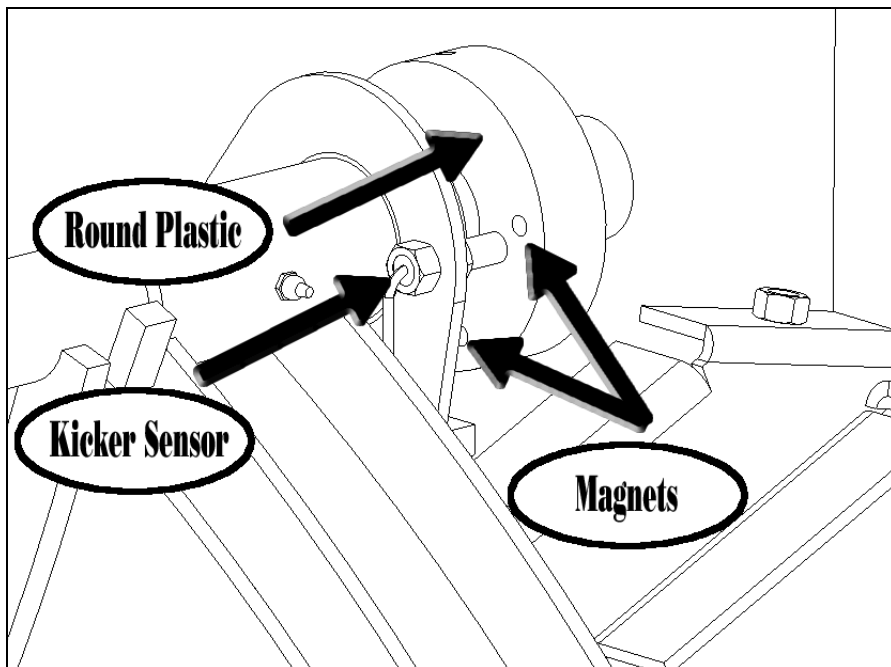
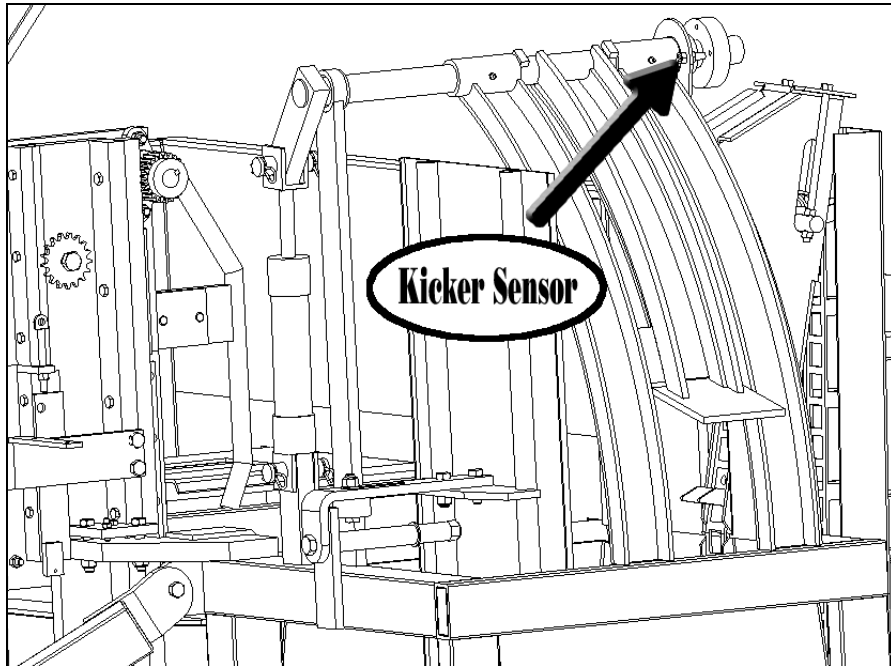

019 Waiting for Horizontal Plunger reed switch to be off.

Note: Before the machine extends the Horizontal Plunger cylinder, the Horizontal Plunger reed switch is in front of the first set of magnets. When the machine extends the Horizontal Plunger cylinder it moves the first magnet away from the switch, which turns the Horizontal Plunger reed switch off. This is what the machine is waiting for.

If the Horizontal Plunger cylinder is fully extended,

- Loosen nuts on Horizontal Plunger reed switch and hold the switch away from any magnets or metal for approximately 10 seconds. Check tractor box display to see if it is still displays “019”. If it does, lightly tap the switch on something to free up the stuck switch. The switch may need to be replaced if this problem continues.

If the Horizontal Plunger cylinder is partially extended,

- Check that a bale or foreign object is not preventing the Horizontal Plunger from extending.
- Hydraulic power or hydraulic return has been disconnected or shut off from machine. This circuit has a 2-position valve and cannot be partially extended unless power or return has been disconnected or shut off.

If the Horizontal Plunger cylinder is still retracted,

- Check that hydraulic power is still on to the machine and that return line is still connected.
- Check that a bale or foreign object is not preventing the Horizontal Plunger from extending.
- Check that the directional valve is not stuck.

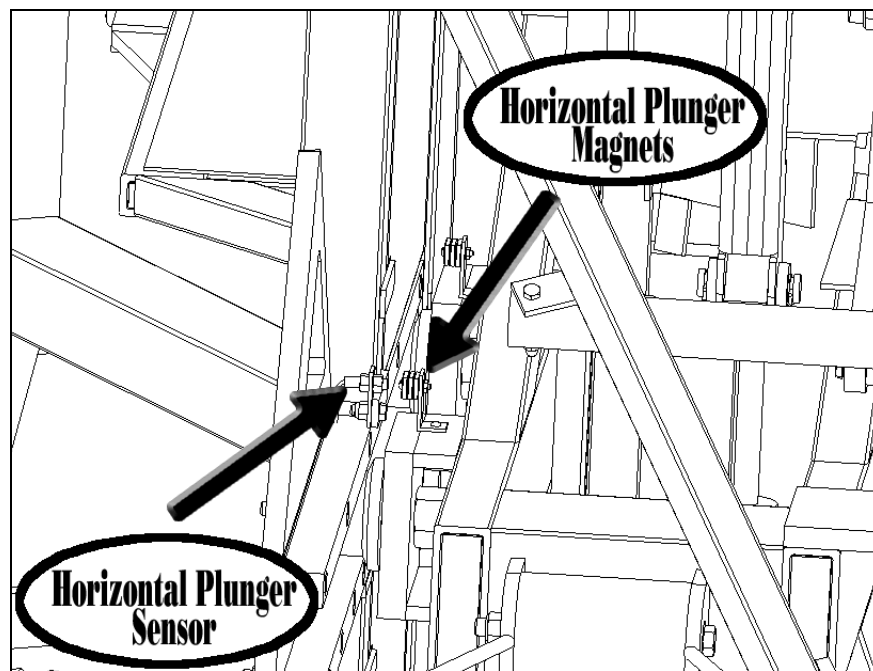

020 Timer Delay Error

- Disengage hydraulic power and unplug main power cord. Wait for approximately 10 seconds, plug back in and engage hydraulic power.

021 Waiting for Horizontal Plunger reed switch to be on.

Note: After the machine has extended the Horizontal Plunger cylinder, the Horizontal Plunger reed switch should be lined up with a set of magnets, which turns the switch on. This is what the machine is waiting for.

If the Horizontal Plunger cylinder is fully extended,

- Check the air gap distance between the Horizontal Plunger reed switch and the magnet. The distance should be a maximum of 3/8 inch (9 mm). If it is within the suggested range then the reed switch needs to be replaced.

If the Horizontal Plunger cylinder is partially extended,

- Check that a bale or foreign object is not preventing the Horizontal Plunger cylinder from extending.
- Hydraulic power or hydraulic return has been disconnected or shut off from machine. This circuit has a 2-position valve and cannot be partially extended unless power or return has been disconnected or shut off.

If the Horizontal Plunger cylinder is still retracted,

- Check that hydraulic power is still on to the machine and that return line is still connected.
- Check that a bale or foreign object is not preventing the Horizontal Plunger cylinder from extending.
- Check that the directional valve is not stuck.

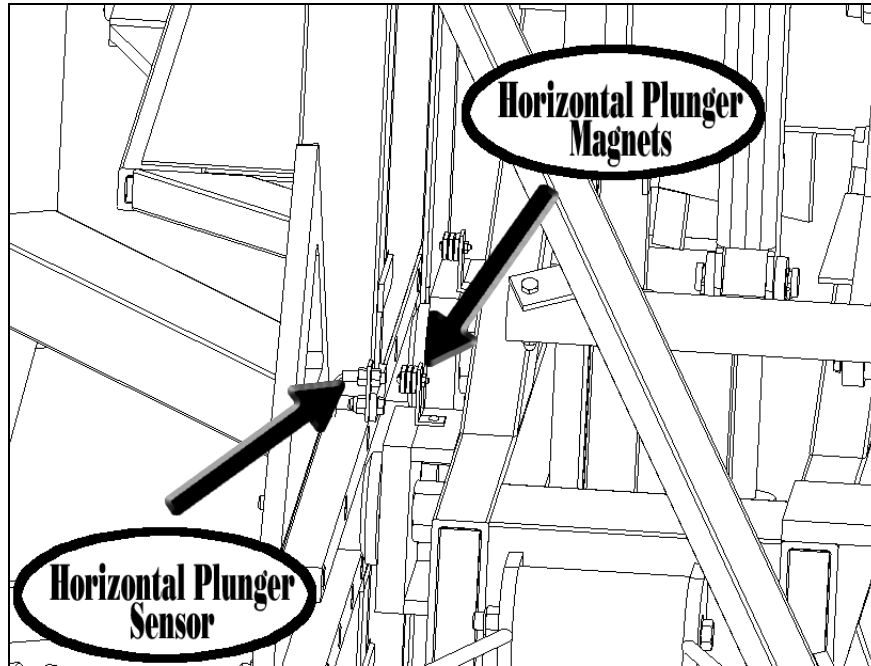

022 Vertical Plunger Up sensor bar switch is stuck on.

Note: Before the machine extends the Vertical Plunger cylinder it does a safety check on the Vertical Plunger Up sensor bar switch. It checks to see if the sensor bar switch is stuck on. If it is, it will wait until the sensor bar switch is off before continuing the operation. The switch is located at the top of the sensor bar at the white mark.

If Vertical Plunger cylinder is retracted,

- Tap on Vertical Plunger Swing sensor bar switch until display number changes or replace the sensor bar.

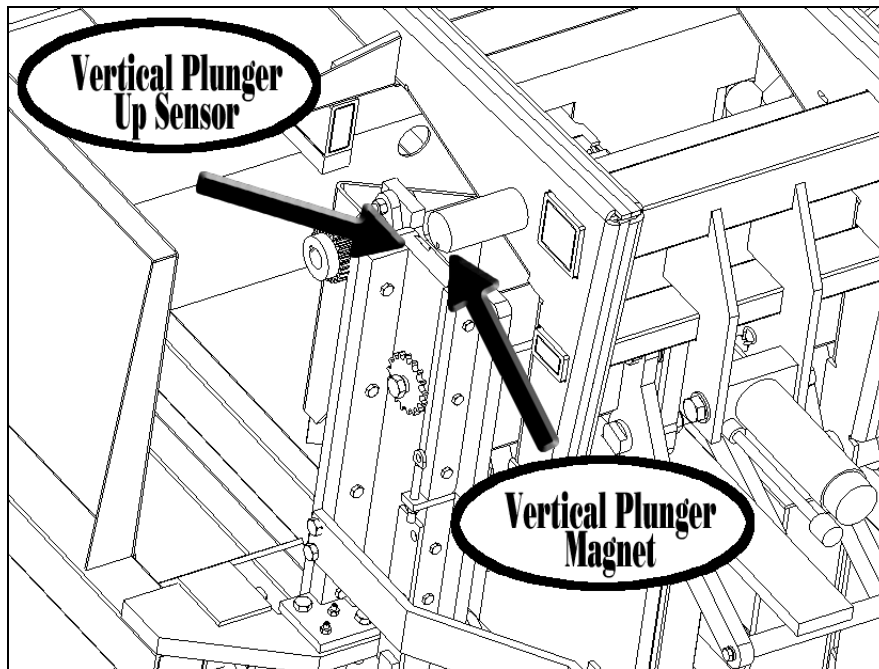

023 Waiting for Vertical Plunger Up sensor bar switch to be on. .

Note: After the machine has extended the Vertical Plunger cylinder, the Vertical Plunger Up magnet should be lined up with the Vertical Plunger sensor bar switch, which turns the switch on. This is what the machine is waiting for. The switch is located at the top of the sensor bar at the white mark.

If the Vertical Plunger cylinder is fully extended,

- Check the air gap distance between the Vertical Plunger sensor bar switch and the magnet. The distance should be a maximum of 3/8 inch (9 mm). If it is within the suggested range then the sensor bar needs to be replaced.

If the Vertical Plunger cylinder is partially extended,

- Check that a bale or foreign object is not preventing the Vertical Plunger cylinder from extending.
- Hydraulic power or hydraulic return has been disconnected or shut off from machine. This circuit has a 2-position valve and cannot be partially extended unless power or return has been disconnected or shut off.

If the Vertical Plunger cylinder is still retracted,

- Check that hydraulic power is still on to the machine and that return line is still connected.
- Check that a bale or foreign object is not preventing the Vertical Plunger cylinder from extending.
- Check that the directional valve is not stuck.

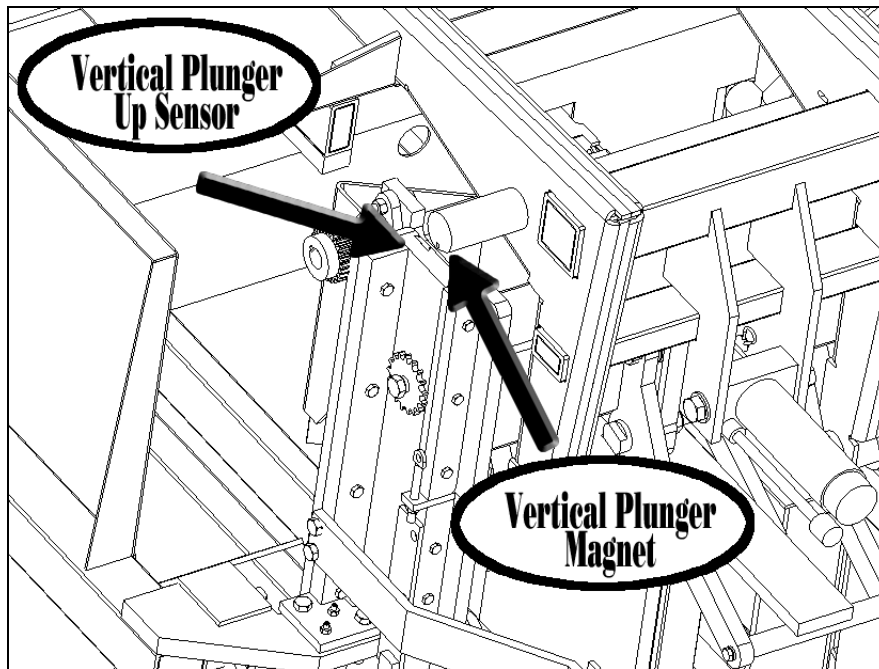

024 Timer Delay Error

- Disengage hydraulic power and unplug main power cord. Wait for approximately 10 seconds, plug back in and engage hydraulic power.

025 Communication from Band Computer

- Disengage hydraulic power and unplug main power cord. Wait for approximately 10 seconds, plug back in and engage hydraulic power.
- On Line 3 of Display Monitor, if the number after the dash is 0, then disconnect main electrical and hydraulic power. Open the plastic computer box in the banding box and unplug the two 10 amp fuses. Reconnect main electrical power only. Wait approximately 10 seconds and then reinstall the two 10 amp fuses at the same time. Recheck number on Line 3 after the dash, it should then be 1. Apply hydraulics.

026 Bale Position 0 sensor bar switch stuck on.

Note: Before the machine raises the Strap Guide Arms it does a safety check on the Bale Position 0 sensor bar switch. It checks to see if the sensor bar switch is stuck on. If it is, it will wait until the sensor bar switch is off before continuing the operation. The switch is located upper mid way of the sensor bar at the brown mark.

- Tap on Bale Position 0 sensor bar switch until display number changes or replace the sensor bar.

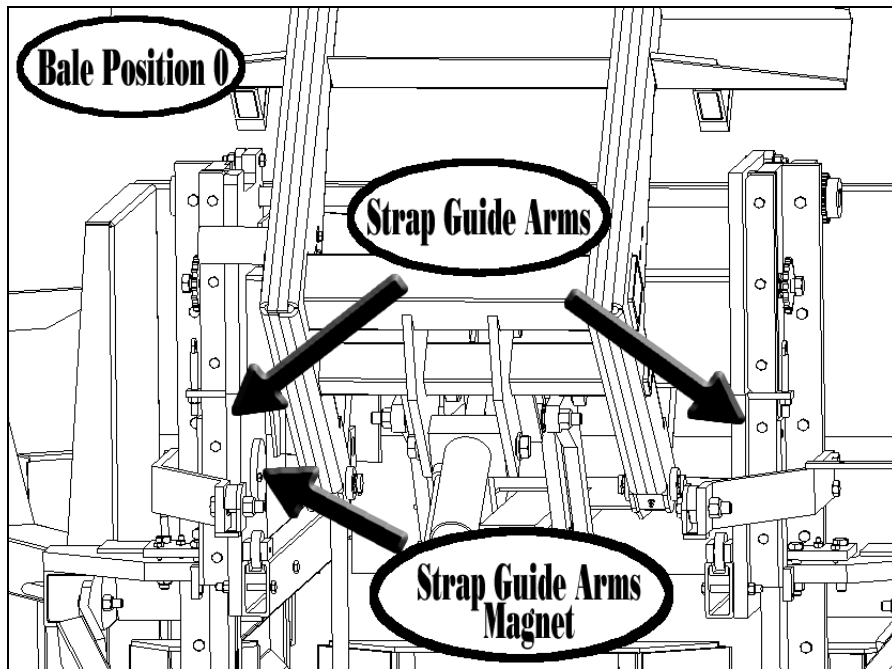

027 Waiting for Strap Guides to be at top position.

Note: The machine has turned on the Strap Guide Arms motor and sent them up. When the Strap Guide Arms magnet reaches the Bale Position 0 sensor bar switch, the machine stops the motor. The machine is waiting for the magnet to reach the Bale Position 0 sensor bar switch. The switch is located upper mid way of the sensor bar at the brown mark.

- Check that Strap Guide Arms are in time with each other. They should be the same height. If their heights vary $\frac{1}{2}$ inch (12.5 mm) or greater then they are at least one gear tooth out of time. A quick way to check their heights is to compare the distance between the Vertical Plunger plates to the Strap Guide plates. The right side should be the same distance as the left side. In order to prevent the Strap Guide arms from getting out of time, keep their chains tight.
- Check that hydraulic power is still on to the machine and that return line is still connected.
- Check that a bale, excess hay or foreign object is not preventing the Strap Guide Arms from rising.
- Check that the directional valve is not stuck.

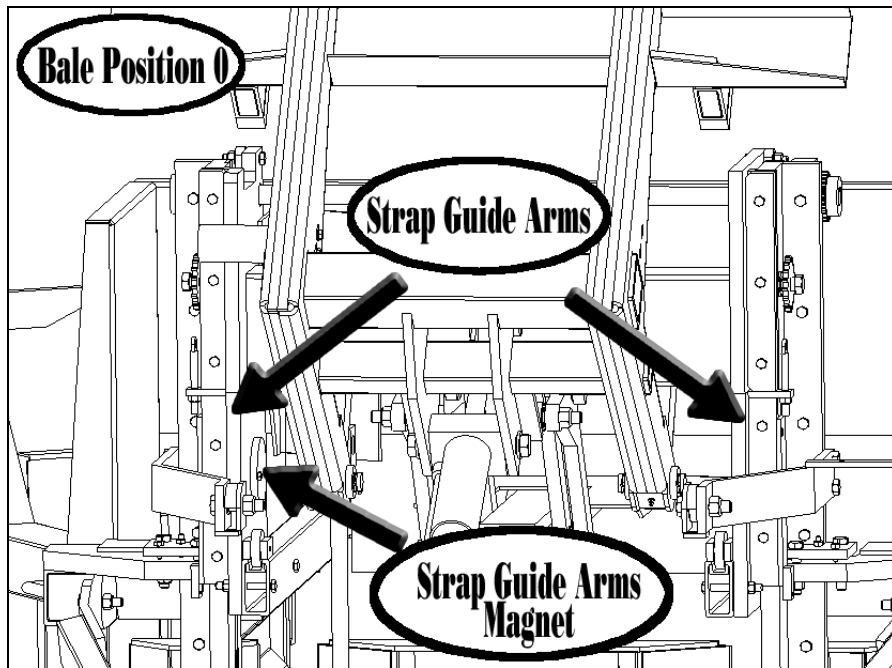
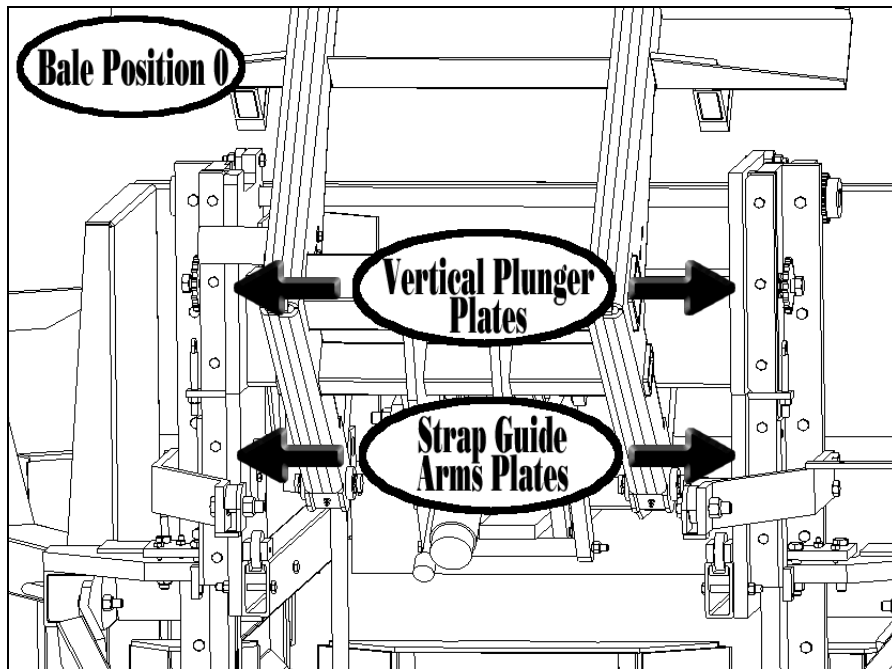

028 Waiting for Strap Guides to be at top position

Note: The machine has turned on the Strap Guide Arms motor and sent them up. When the Strap Guide Arms magnet reaches the Bale Position 0 sensor bar switch, the machine stops the motor. The machine is waiting for the magnet to reach the Bale Position 0 sensor bar. The switch is located upper mid way of the sensor bar at the brown mark.

- Check that Strap Guide Arms are in time with each other. They should be the same height. If their heights vary $\frac{1}{2}$ inch (12.5 mm) or greater then they are at least one gear tooth out of time. A quick way to check their heights is to compare the distance between the Vertical Plunger plates to the Strap Guide plates. The right side should

be the same distance as the left side. In order to prevent the Strap Guide arms from getting out of time, keep their chains tight.

- Check that hydraulic power is still on to the machine and that return line is still connected.
- Check that a bale, excess hay or foreign object is not preventing the Strap Guide Arms from rising.
- Check that the directional valve is not stuck.

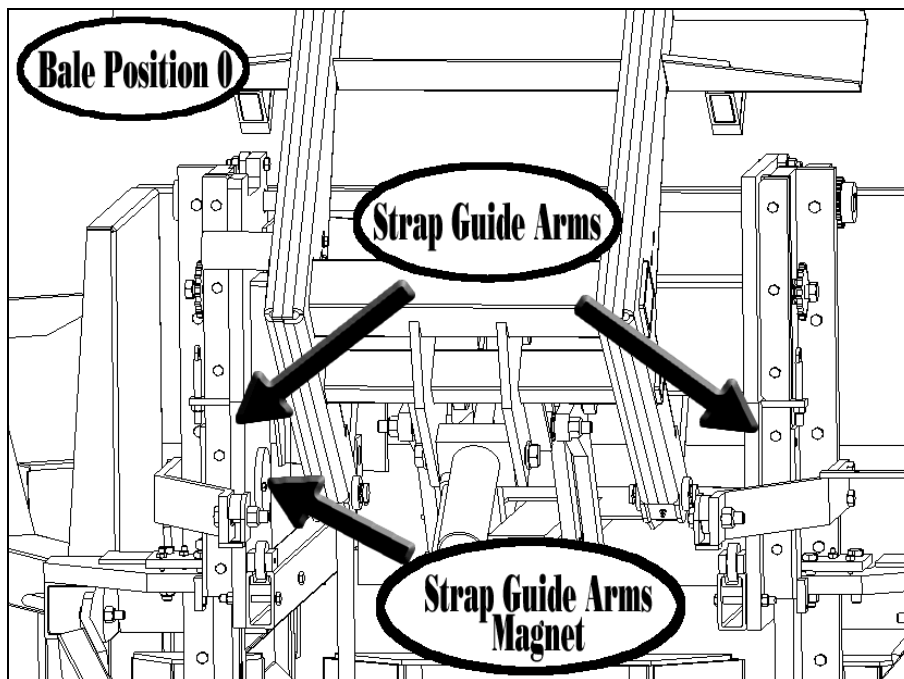
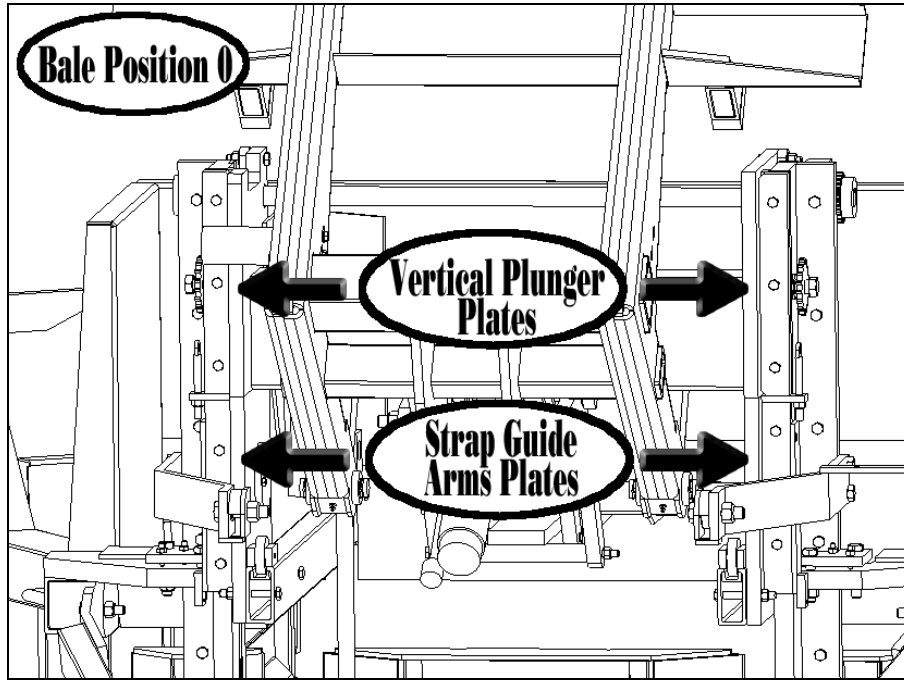

029 Communication from Band Computer

- Disengage hydraulic power and unplug main power cord. Wait for approximately 10 seconds, plug back in and engage hydraulic power.

- On Line 3 of Display Monitor, if the number after the dash is 0, then disconnect main electrical and hydraulic power. Open the plastic computer box in the banding box and unplug the two 10 amp fuses. Reconnect main electrical power only. Wait approximately 10 seconds and then reinstall the two 10 amp fuses at the same time. Recheck number on Line 3 after the dash, it should then be 1. Apply hydraulics.

030 Timer Delay Error

- Disengage hydraulic power and unplug main power cord. Wait for approximately 10 seconds, plug back in and engage hydraulic power.

031 Waiting for Strap Guides to be at top position.

Note: The machine has turned on the Strap Guide Arms motor and sent them up. When the Strap Guide Arms magnet reaches the Bale Position 0 sensor bar switch, the machine stops the motor. The machine is waiting for the magnet to reach the Bale Position 0 sensor bar. The switch is located upper mid way of the sensor bar at the brown mark.

- Check that Strap Guide Arms are in time with each other. They should be the same height. If their heights vary ½ inch (12.5 mm) or greater then they are at least one gear tooth out of time. A quick way to check their heights is to compare the distance between the Vertical Plunger plates to the Strap Guide plates. The right side should be the same distance as the left side. In order to prevent the Strap Guide arms from getting out of time, keep their chains tight.

- Check that hydraulic power is still on to the machine and that return line is still connected.

- Check that a bale, excess hay or foreign object is not preventing the Strap Guide Arms from rising.

- Check that the directional valve is not stuck.

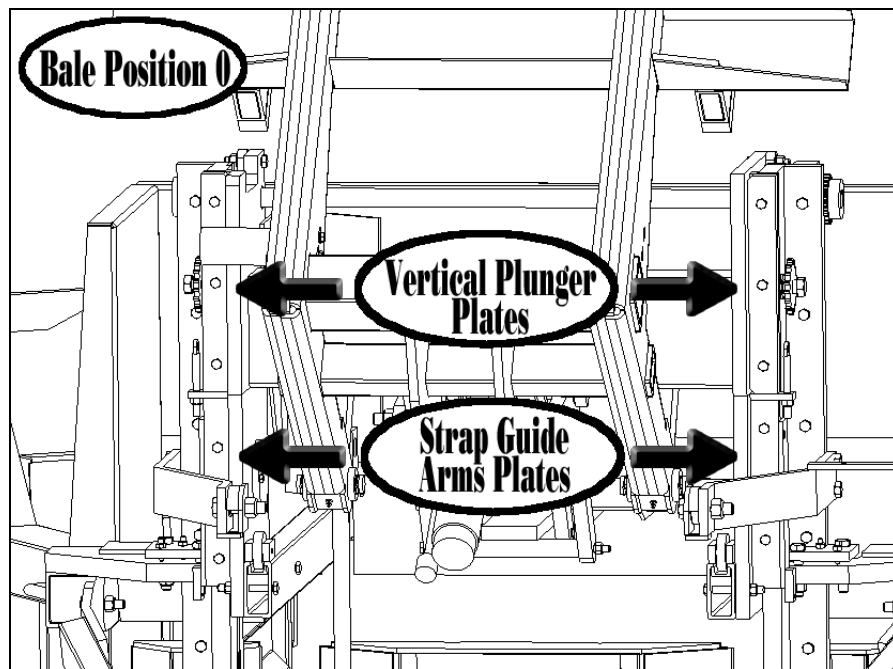

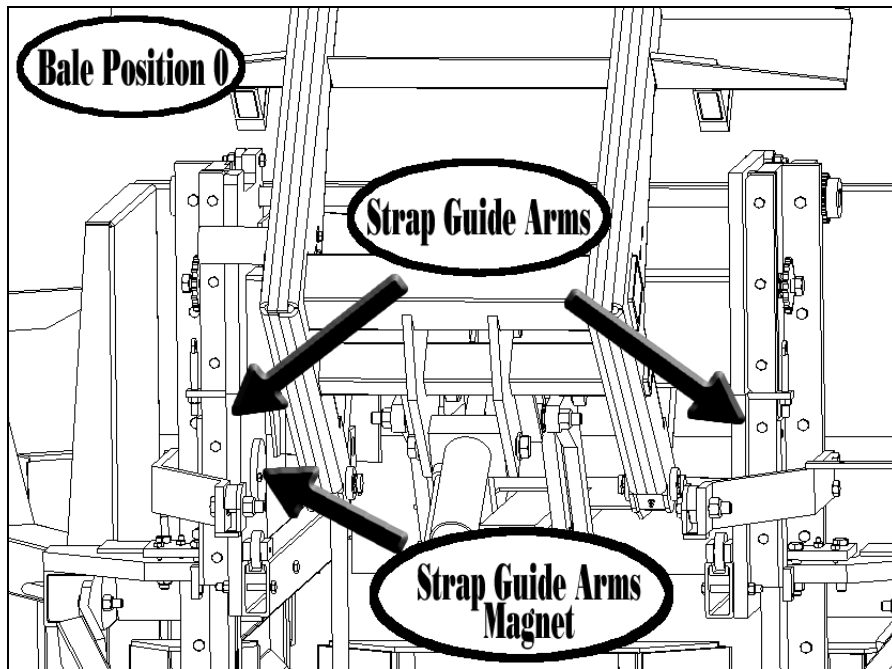

032 Waiting for Vertical Plunger Up sensor bar switch to be off.

Note: After the machine has extended the Vertical Plunger Swing cylinder, the Vertical Plunger magnet should be moved away from the Vertical Plunger Up sensor bar switch, which turns the switch off. This is what the machine is waiting for. The switch is located at the top of the sensor bar at the white mark.

If the Vertical Plunger Swing cylinder is fully extended,

- If the Vertical Plunger Swing cylinder is fully extended then no magnets or metallic materials should be near the switch. Lightly tap the switch to free up the stuck switch. The switch may need to be replaced if this problem continues.

If the Vertical Plunger Swing cylinder is partially extended,

- Check that a bale or foreign object is not preventing the Vertical Plunger Swing cylinder from extending.
- Hydraulic power or hydraulic return has been disconnected or shut off from machine. This circuit has a 2-position valve and cannot be partially extended unless power or return has been disconnected or shut off.

If the Vertical Plunger Swing cylinder is still retracted,

- Check that hydraulic power is still on to the machine and that return line is still connected.
- Check that a bale or foreign object is not preventing the Vertical Plunger Swing cylinder from extending.
- Check that the directional valve is not stuck.

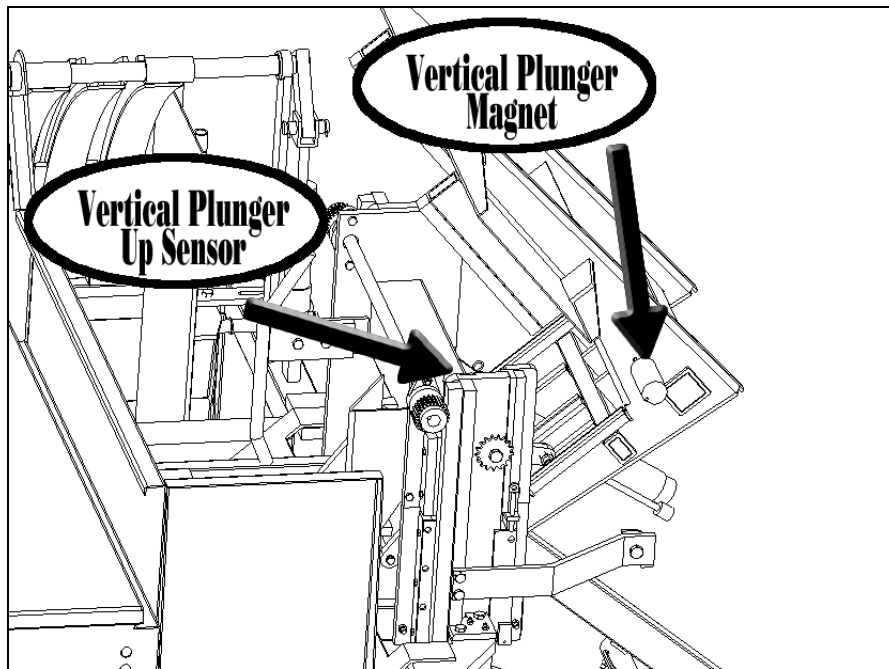

033 Waiting for Vertical Plunger Up sensor bar switch to be on.

Note: This code occurs when the Reset Bundle button has been pressed. The machine begins its reset mode. In order to properly reset the machine it retracts the Vertical Plunger cylinder (unless it is already retracted) and waits for the Vertical Plunger magnet to be in front of the Vertical Plunger Up sensor bar switch. The switch is located at the top of the sensor bar at the white mark.

If the Vertical Plunger Swing cylinder is fully retracted,

- Check the air gap distance between the Vertical Plunger Up sensor bar switch and the magnet. The distance should be a maximum of 3/8 inch (9 mm). If it is within the suggested range then the sensor bar needs to be replaced.

If the Vertical Plunger Swing cylinder is partially retracted,

- Check that a bale or foreign object is not preventing the Vertical Plunger Swing cylinder from retracting.
- Hydraulic power or hydraulic return has been disconnected or shut off from machine. This circuit has a 2-position valve and cannot be partially extended unless power or return has been disconnected or shut off.

If the Vertical Plunger Swing cylinder is still extended,

- Check that hydraulic power is still on to the machine and that return line is still connected.
- Check that a bale or foreign object is not preventing the Vertical Plunger Swing cylinder from retracting.
- Check that the directional valve is not stuck.

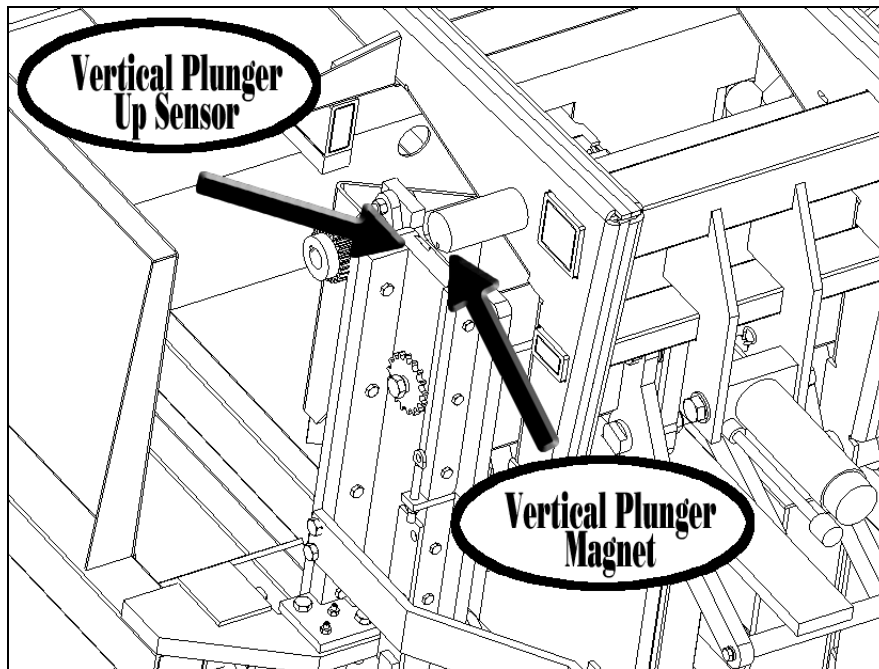

034 Left Band Full reed switch is stuck on.

Note: Before the machine extends the Right/Left Mid Banding Position cylinders it does a safety check on the Left Band Full reed switch. It checks to see if the reed switch is stuck on. If it is, it will wait until the reed switch is off before continuing the operation.

- Loosen nuts on Left Band Full reed switch and hold the switch away from any magnets or metal for approximately 10 seconds. Check tractor box display to see if it is still displays “034”. If it does, lightly tap the switch on something to free up the stuck switch. The switch may need to be replaced if this problem continues.

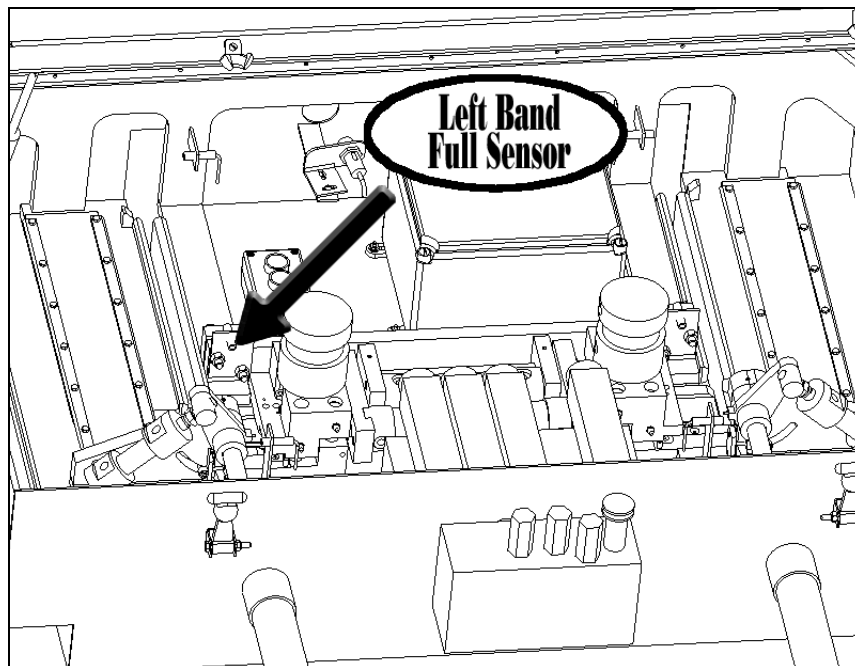

035 Right Band Full reed switch is stuck on.

Note: Before the machine extends the Right/Left Mid Banding Position cylinders it does a safety check on the Right Band Full reed switch. It checks to see if the reed switch is stuck on. If it is, it will wait until the reed switch is off before continuing the operation.

- Loosen nuts on Right Band Full reed switch and hold the switch away from any magnets or metal for approximately 10 seconds. Check tractor box display to see if it is still displays “035”. If it does, lightly tap the switch on something to free up the stuck switch. The switch may need to be replaced if this problem continues.

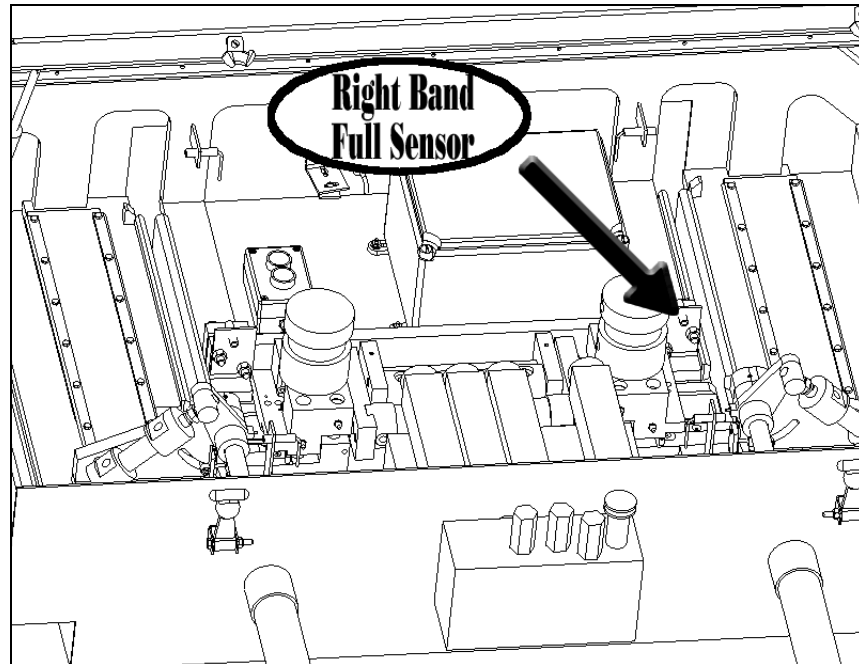

036 Timer Delay Error

- Disengage hydraulic power and unplug main power cord. Wait for approximately 10 seconds, plug back in and engage hydraulic power.

037 Communication from Band Computer

- Disengage hydraulic power and unplug main power cord. Wait for approximately 10 seconds, plug back in and engage hydraulic power.
- On Line 3 of Display Monitor, if the number after the dash is 0, then disconnect main electrical and hydraulic power. Open the plastic computer box in the banding box and unplug the two 10 amp fuses. Reconnect main electrical power only. Wait approximately 10 seconds and then reinstall the two 10 amp fuses at the same time. Recheck number on Line 3 after the dash, it should then be 1. Apply hydraulics.

038 Timer Delay Error

- Disengage hydraulic power and unplug main power cord. Wait for approximately 10 seconds, plug back in and engage hydraulic power.

039 Communication from Band Computer

- Disengage hydraulic power and unplug main power cord. Wait for approximately 10 seconds, plug back in and engage hydraulic power.
- On Line 3 of Display Monitor, if the number after the dash is 0, then disconnect main electrical and hydraulic power. Open the plastic computer box in the banding box and unplug the two 10 amp fuses. Reconnect main electrical power only. Wait approximately 10 seconds and then reinstall the two 10 amp fuses at the same time. Recheck number on Line 3 after the dash, it should then be 1. Apply hydraulics.

040 Left Fetcher Out reed switch is stuck on.

Note: Before the machine extends the Right/Left Fetcher cylinders it does a safety check on the Left Fetcher Out reed switch. It checks to see if the reed switch is stuck on. If it is, it will wait until the reed switch is off before continuing the operation.

- Loosen nuts on Left Fetcher Out reed switch and hold the switch away from any magnets or metal for approximately 10 seconds. Check tractor box display to see if it is still displays “040”. If it does, lightly tap the switch on something to free up the stuck switch. The switch may need to be replaced if this problem continues.

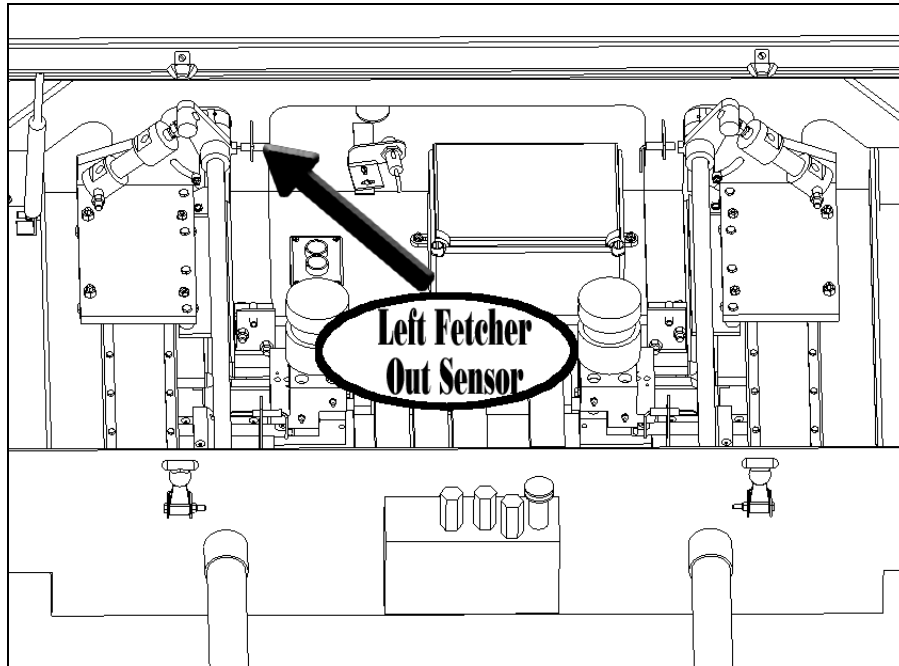

041 Right Fetcher Out reed switch is stuck on.

Note: Before the machine extends the Right/Left Fetcher cylinders it does a safety check on the Right Fetcher Out reed switch. It checks to see if the reed switch is stuck on. If it is, it will wait until the reed switch is off before continuing the operation.

- Loosen nuts on Right Fetcher Out reed switch and hold the switch away from any magnets or metal for approximately 10 seconds. Check tractor box display to see if it is still displays “041”. If it does, lightly tap the switch on something to free up the stuck switch. The switch may need to be replaced if this problem continues.

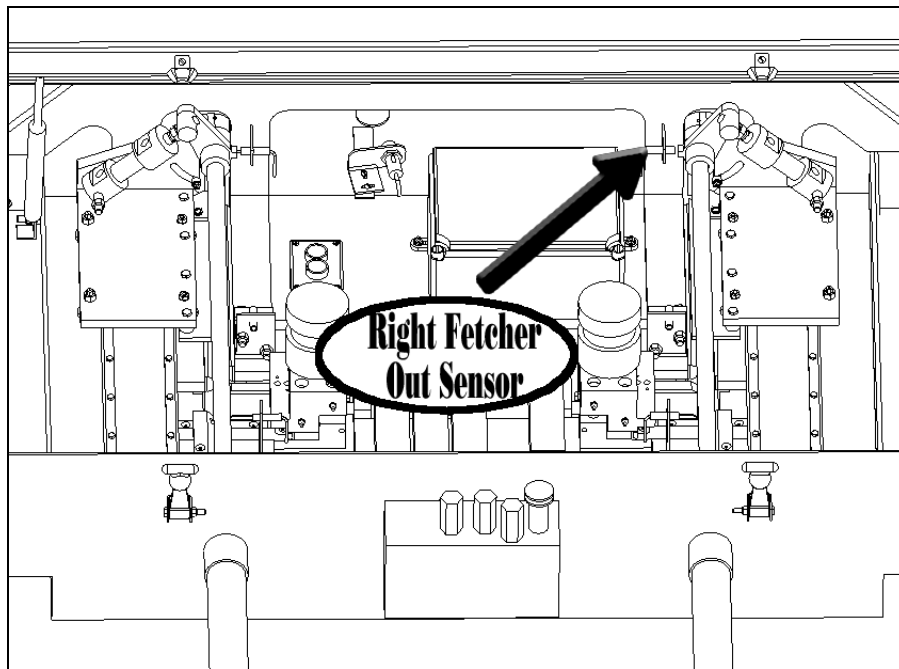

042 Timer Delay Error

- Disengage hydraulic power and unplug main power cord. Wait for approximately 10 seconds, plug back in and engage hydraulic power.

043 Communication from Band Computer

- Disengage hydraulic power and unplug main power cord. Wait for approximately 10 seconds, plug back in and engage hydraulic power.
- On Line 3 of Display Monitor, if the number after the dash is 0, then disconnect main electrical and hydraulic power. Open the plastic computer box in the banding box and unplug the two 10 amp fuses. Reconnect main electrical power only. Wait approximately 10 seconds and then reinstall the two 10 amp fuses at the same time. Recheck number on Line 3 after the dash, it should then be 1. Apply hydraulics.

044 Communication from Band Computer

- Disengage hydraulic power and unplug main power cord. Wait for approximately 10 seconds, plug back in and engage hydraulic power.
- On Line 3 of Display Monitor, if the number after the dash is 0, then disconnect main electrical and hydraulic power. Open the plastic computer box in the banding box and unplug the two 10 amp fuses. Reconnect main electrical power only. Wait approximately 10 seconds and then reinstall the two 10 amp fuses at the same time. Recheck number on Line 3 after the dash, it should then be 1. Apply hydraulics.

045 Waiting for Left Fetcher Out reed switch to be on.

Note: After the machine has extended the Right/Left Fetcher cylinder, the Left Fetcher Out reed switch should be lined up with the Left Fetcher magnet, which turns the switch on. This is what the machine is waiting for.

- If the Left Fetcher cylinder is fully extended,
 - Check the air gap distance between the Left Fetcher Out reed switch and the magnet. The distance should be a maximum of 1/8 inch (3 mm). If it is within the suggested range then the reed switch needs to be replaced.
- If the Left Fetcher cylinder is partially extended,

- Check that a foreign object is not preventing the Left Fetcher cylinder from extending.
- Electric power or hydraulic power or hydraulic return has been disconnected or shut off from machine.
- Remove and observe the Fetcher check valve. If the snap ring in the bottom of the check valve is missing then the check valve needs to be replaced. If you are unable to push the plunger from the end of the check valve in and it spring back, then the check valve needs to be replaced.
- If the Left Fetcher cylinder is still retracted,
 - Check that hydraulic power is still on to the machine and that return line is still connected.
 - Check that a foreign object is not preventing the Left Fetcher cylinder from extending.
 - Remove and observe the Fetcher check valve. If the snap ring in the bottom of the check valve is missing then the check valve needs to be replaced. If you are unable to push the plunger from the end of the check valve in and it spring back, then the check valve needs to be replaced.
 - Check that the directional valve is not stuck.

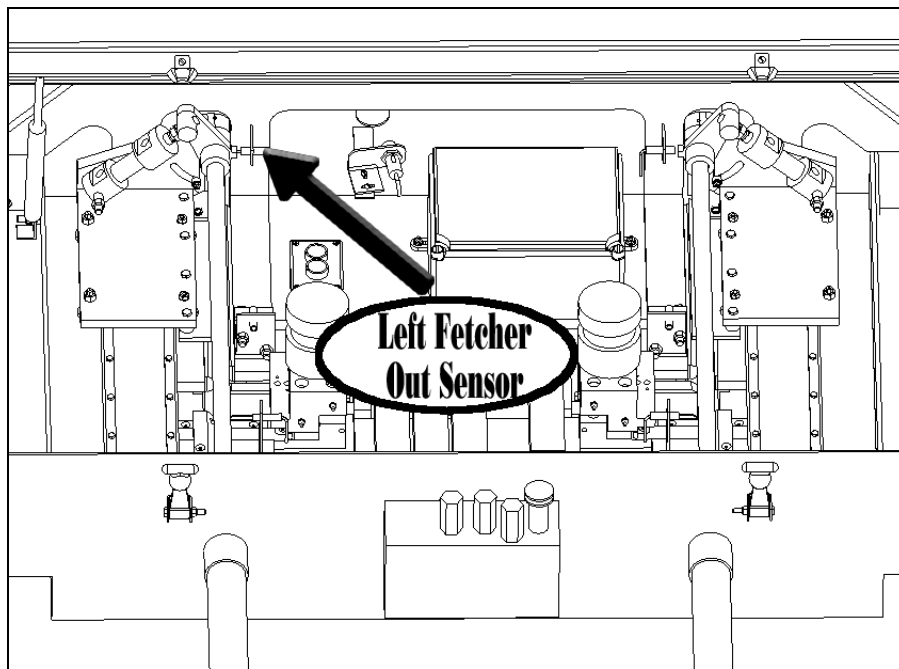

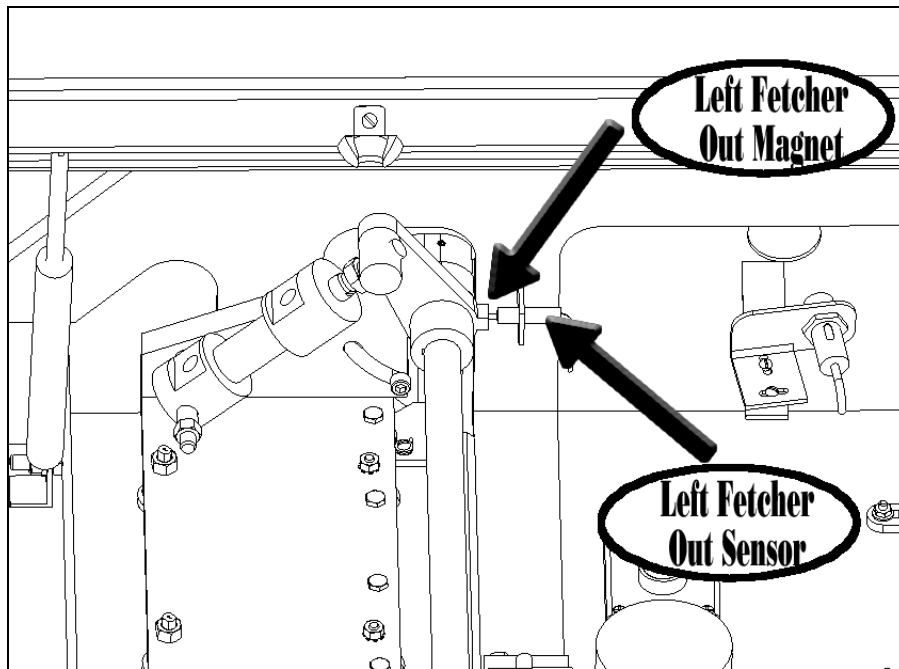

046 Waiting for Right Fetcher Out reed switch to be on.

Note: After the machine has extended the Right/Left Fetcher cylinder, the Right Fetcher Out reed switch should be lined up with the Right Fetcher magnet, which turns the switch on. This is what the machine is waiting for.

- If the Right Fetcher cylinder is fully extended,
 - Check the air gap distance between the Right Fetcher Out reed switch and the magnet. The distance should be a maximum of 1/8 inch (3 mm). If it is within the suggested range then the reed switch needs to be replaced.
- If the Right Fetcher cylinder is partially extended,
 - Check that a foreign object is not preventing the Right Fetcher cylinder from extending.
 - Electric power or hydraulic power or hydraulic return has been disconnected or shut off from machine.
 - Remove and observe the Fetcher check valve. If the snap ring in the bottom of the check valve is missing then the check valve needs to be replaced. If you are unable to push the plunger from the end of the check valve in and it spring back, then the check valve needs to be replaced.
- If the Right Fetcher cylinder is still retracted,
 - Check that hydraulic power is still on to the machine and that return line is still connected.
 - Check that a foreign object is not preventing the Right Fetcher cylinder from extending.
 - Remove and observe the Fetcher check valve. If the snap ring in the bottom of the check valve is missing then the check valve needs to be replaced. If you are unable to push the plunger from the end of the check valve in and it spring back, then the check valve needs to be replaced.
 - Check that the directional valve is not stuck.

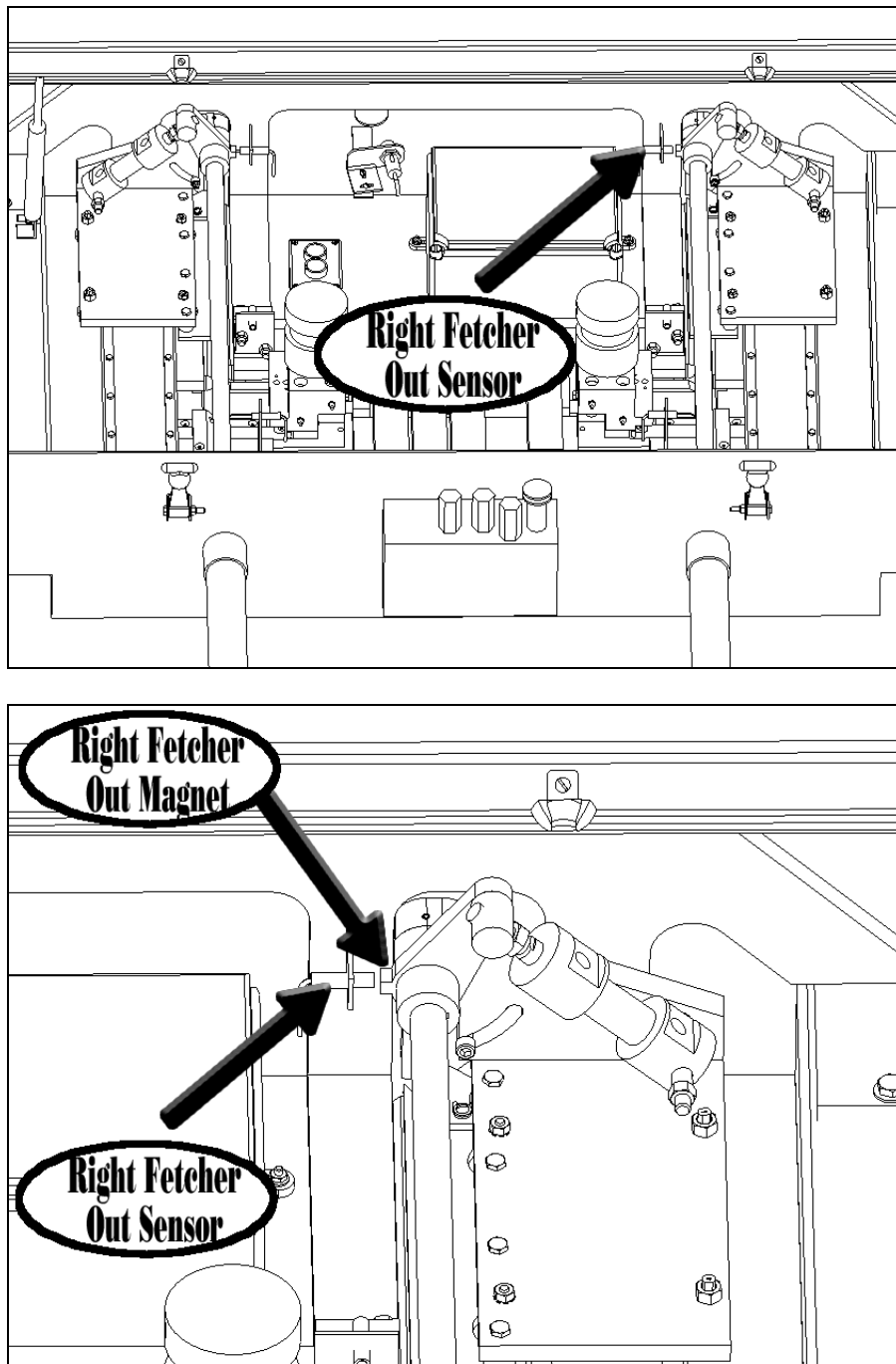

047 **Timer Delay Error**

- Disengage hydraulic power and unplug main power cord. Wait for approximately 10 seconds, plug back in and engage hydraulic power.

048 **Communication from Band Computer**

- Disengage hydraulic power and unplug main power cord. Wait for approximately 10 seconds, plug back in and engage hydraulic power.
- On Line 3 of Display Monitor, if the number after the dash is 0, then disconnect main electrical and hydraulic power. Open the plastic computer box in the banding box and unplug the two 10 amp fuses. Reconnect main electrical power only. Wait approximately 10 seconds and then reinstall the two 10 amp fuses at the same time. Recheck number on Line 3 after the dash, it should then be 1. Apply hydraulics.

049 Waiting for Left Fetcher Out reed switch to be off.

Note: The machine has extended the Right/Left Fetcher Swing cylinders. When they are extended it rotates the Left Fetcher magnet away from the Left Fetcher Out reed switch, which turns the switch off. This is what the machine is waiting for.

- If the Left Fetcher Swing cylinder is fully extended,
 - Loosen nuts on Left Fetcher Out reed switch and hold the switch away from any magnets or metal for approximately 10 seconds. Check tractor box display to see if it is still displays “049”. If it does, lightly tap the switch on something to free up the stuck switch. The switch may need to be replaced if this problem continues.
- If the Left Fetcher Swing cylinder is partially extended,
 - Check that a foreign object is not preventing the Left Fetcher Swing cylinder from extending.
 - Check to see if the Left Fetcher is hitting the Strap Guide Arms. If it is, check that the Strap Guide Arms are in time with each other. They should be the same height. If their heights vary ½ inch (12.5 mm) or greater then they are at least one gear tooth out of time. A quick way to check their heights is to compare the distance between the Vertical Plunger plates to the Strap Guide plates. In order to prevent the Strap Guide arms from getting out of time, keep their chains tight.
 - Electric power or hydraulic power or hydraulic return has been disconnected or shut off from machine.
- If the Left Fetcher Swing cylinder is still retracted,
 - Check that hydraulic power is still on to the machine and that return line is still connected.
 - Check that a foreign object is not preventing the Left Fetcher Swing cylinder from extending.
 - Check that the directional valve is not stuck.

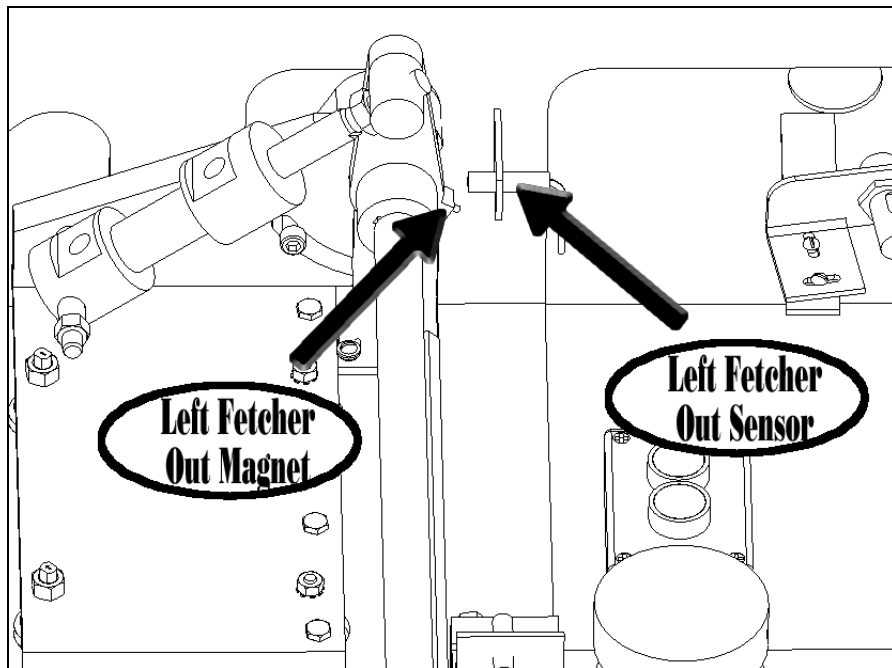

050 Waiting for Right Fetcher Out reed switch to be off.

Note: The machine has extended the Right/Left Fetcher Swing cylinders. When they are extended it rotates the Right Fetcher magnet away from the Right Fetcher Out reed switch, which turns the switch off. This is what the machine is waiting for.

- If the Right Fetcher Swing cylinder is fully extended,

- Loosen nuts on Right Fetcher Out reed switch and hold the switch away from any magnets or metal for approximately 10 seconds. Check tractor box display to see if it is still displays “050”. If it does, lightly tap the switch on something to free up the stuck switch. The switch may need to be replaced if this problem continues.
- If the Right Fetcher Swing cylinder is partially extended,
 - Check that a foreign object is not preventing the Right Fetcher Swing cylinder from extending.
 - Check to see if the Right Fetcher is hitting the Strap Guide Arms. If it is, check that the Strap Guide Arms are in time with each other. They should be the same height. If their heights vary ½ inch (12.5 mm) or greater then they are at least one gear tooth out of time. A quick way to check their heights is to compare the distance between the Vertical Plunger plates to the Strap Guide plates. In order to prevent the Strap Guide arms from getting out of time, keep their chains tight.
 - Electric power or hydraulic power or hydraulic return has been disconnected or shut off from machine.
- If the Right Fetcher Swing cylinder is still retracted,
 - Check that hydraulic power is still on to the machine and that return line is still connected.
 - Check that a foreign object is not preventing the Right Fetcher Swing cylinder from extending.
 - Check that the directional valve is not stuck.

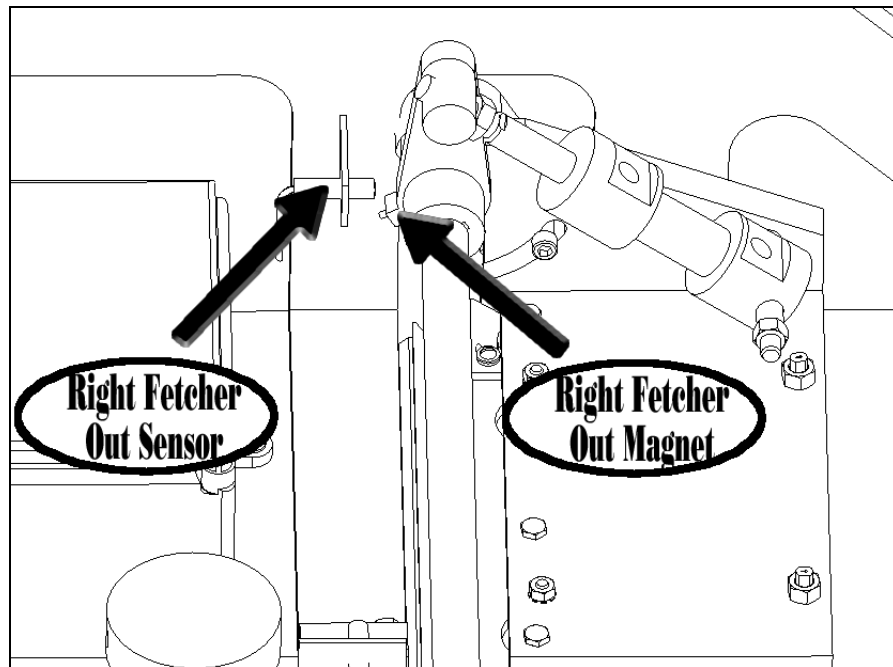

051 Communication from Band Computer

- Disengage hydraulic power and unplug main power cord. Wait for approximately 10 seconds, plug back in and engage hydraulic power.
- On Line 3 of Display Monitor, if the number after the dash is 0, then disconnect main electrical and hydraulic power. Open the plastic computer box in the banding box and unplug the two 10 amp fuses. Reconnect main electrical power only. Wait approximately 10 seconds and then reinstall the two 10 amp fuses at the same time. Recheck number on Line 3 after the dash, it should then be 1. Apply hydraulics.

052 Waiting for Left Fetcher Out reed switch to be on.

Note: After the machine has retracted the Right/Left Fetcher Swing cylinders, the Left Fetcher Out reed switch should be lined up with the Left Fetcher magnet, which turns the switch on. This is what the machine is waiting for.

- If the Left Fetcher Swing cylinder is fully retracted,
 - Check the air gap distance between the Left Fetcher Out reed switch and the magnet. The distance should be a maximum of 1/8 inch (3 mm). If it is within the suggested range then the reed switch needs to be replaced.
- If the Left Fetcher Swing cylinder is partially retracted,
 - Check that a foreign object is not preventing the Left Fetcher Swing cylinder from retracting.
 - Check to see if the Left Fetcher is hitting the Strap Guide Arms. If it is, check that the Strap Guide Arms are in time with each other. They should be the same height. If their heights vary ½ inch (12.5 mm) or greater then they are at least one gear tooth out of time. A quick way to check their heights is to compare the distance between the Vertical Plunger plates to the Strap Guide plates. In order to prevent the Strap Guide arms from getting out of time, keep their chains tight.
 - Electric power or hydraulic power or hydraulic return has been disconnected or shut off from machine.
- If the Left Fetcher Swing cylinder is still extended,
 - Check that hydraulic power is still on to the machine and that return line is still connected.
 - Check that a foreign object is not preventing the Left Fetcher Swing cylinder from retracting.
 - Check that the directional valve is not stuck.

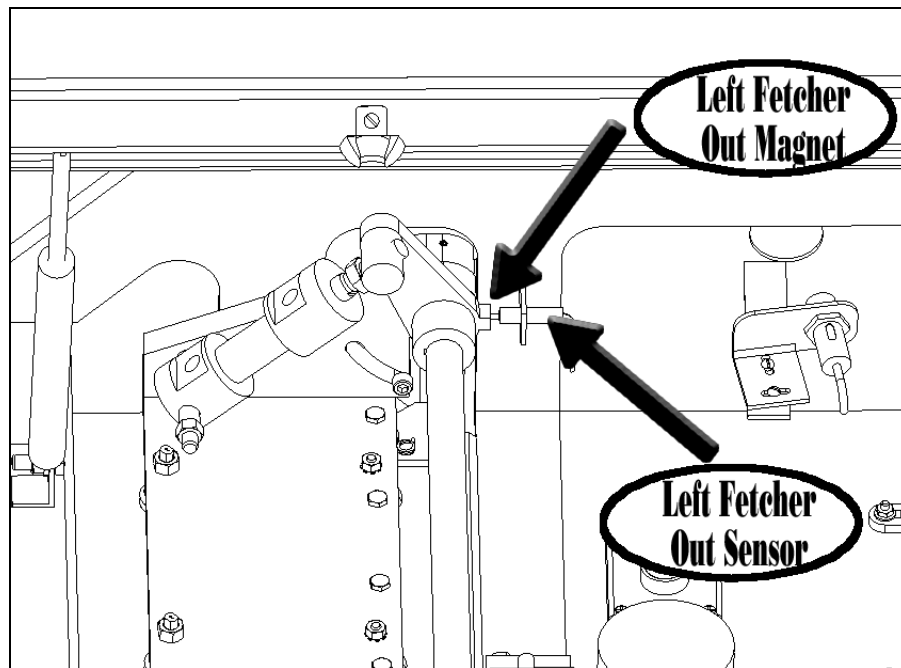

053 Waiting for Right Fetcher Out reed switch to be on.

Note: After the machine has retracted the Right/Left Fetcher Swing cylinders, the Right Fetcher Out reed switch should be lined up with the Left Fetcher magnet, which turns the switch on. This is what the machine is waiting for.

- If the Right Fetcher Swing cylinder is fully retracted,

- Check the air gap distance between the Right Fetcher Out reed switch and the magnet. The distance should be a maximum of 1/8 inch (3 mm). If it is within the suggested range then the reed switch needs to be replaced.
- If the Right Fetcher Swing cylinder is partially retracted,
 - Check that a foreign object is not preventing the Right Fetcher Swing cylinder from retracting.
 - Check to see if the Right Fetcher is hitting the Strap Guide Arms. If it is, check that the Strap Guide Arms are in time with each other. They should be the same height. If their heights vary 1/2 inch (12.5 mm) or greater then they are at least one gear tooth out of time. A quick way to check their heights is to compare the distance between the Vertical Plunger plates to the Strap Guide plates. In order to prevent the Strap Guide arms from getting out of time, keep their chains tight.
 - Electric power or hydraulic power or hydraulic return has been disconnected or shut off from machine.
- If the Right Fetcher Swing cylinder is still extended,
 - Check that hydraulic power is still on to the machine and that return line is still connected.
 - Check that a foreign object is not preventing the Right Fetcher Swing cylinder from retracting.
 - Check that the directional valve is not stuck.

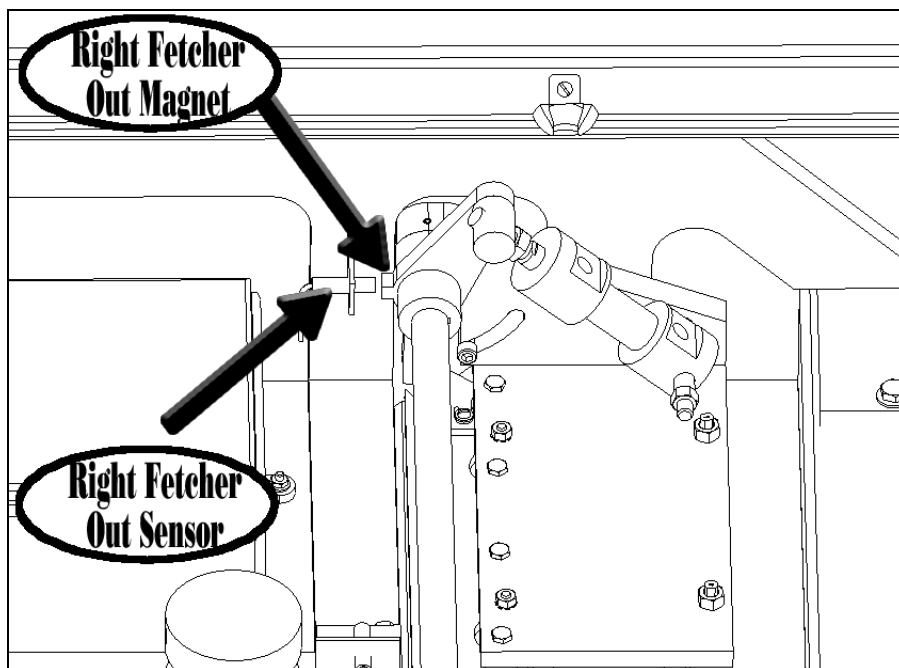

054 Timer Delay Error

- Disengage hydraulic power and unplug main power cord. Wait for approximately 10 seconds, plug back in and engage hydraulic power.

055 Left Fetcher In reed switch is stuck on.

Note: Before the machine retracts the Right/Left Fetcher cylinders it does a safety check on the Left Fetcher In reed switch. It checks to see if the reed switch is stuck on. If it is, it will wait until the reed switch is off before continuing the operation.

- Loosen nuts on Left Fetcher In reed switch and hold the switch away from any magnets or metal for approximately 10 seconds. Check tractor box display to see if it

is still displays “055”. If it does, lightly tap the switch on something to free up the stuck switch. The switch may need to be replaced if this problem continues.

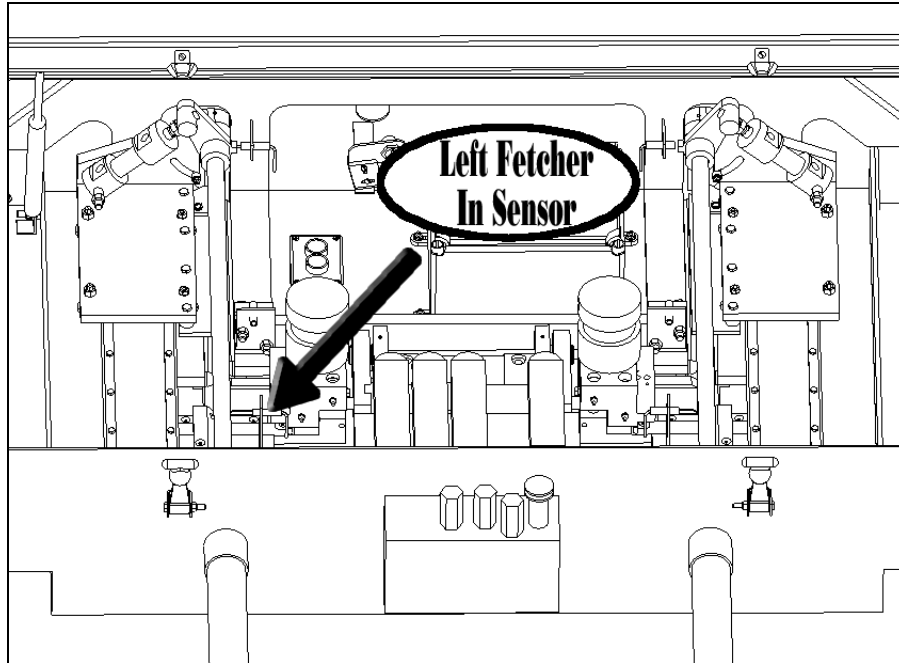

056 Right Fetcher In reed switch is stuck on.

Note: Before the machine retracts the Right/Left Fetcher cylinders it does a safety check on the Right Fetcher In reed switch. It checks to see if the reed switch is stuck on. If it is, it will wait until the reed switch is off before continuing the operation.

- Loosen nuts on Right Fetcher In reed switch and hold the switch away from any magnets or metal for approximately 10 seconds. Check tractor box display to see if it is still displays “056”. If it does, lightly tap the switch on something to free up the stuck switch. The switch may need to be replaced if this problem continues.

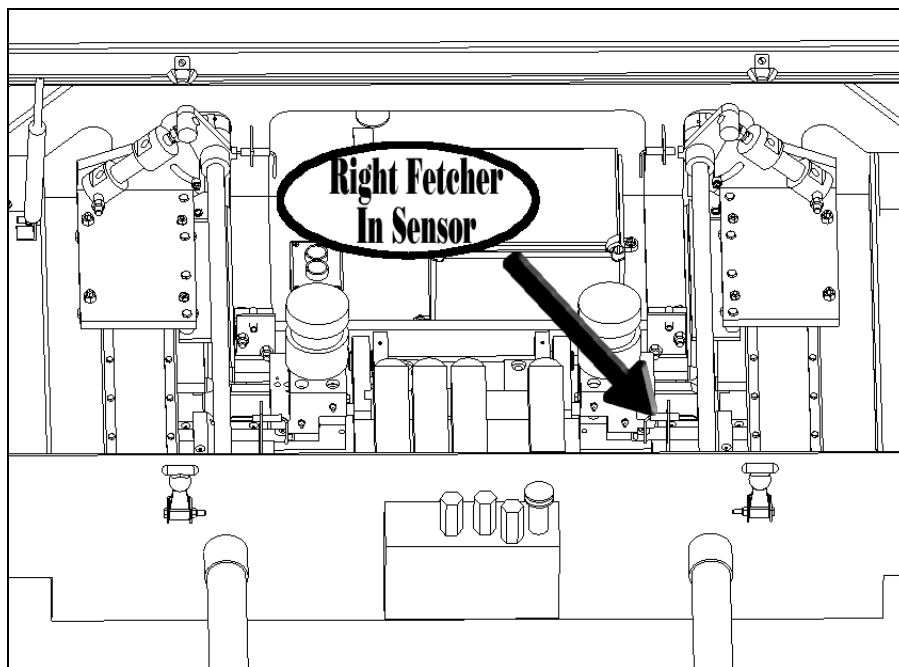

057 Communication from Band Computer

- Disengage hydraulic power and unplug main power cord. Wait for approximately 10 seconds, plug back in and engage hydraulic power.
- On Line 3 of Display Monitor, if the number after the dash is 0, then disconnect main electrical and hydraulic power. Open the plastic computer box in the banding box and unplug the two 10 amp fuses. Reconnect main electrical power only. Wait approximately 10 seconds and then reinstall the two 10 amp fuses at the same time. Recheck number on Line 3 after the dash, it should then be 1. Apply hydraulics.

058 Waiting for Left Fetcher In reed switch to be on.

Note: After the machine has retracted the Right/Left Fetcher cylinder, the Left Fetcher In reed switch should be lined up with the Left Fetcher magnet, which turns the switch on. This is what the machine is waiting for.

- If the Left Fetcher cylinder is fully retracted,
 - Check the air gap distance between the Left Fetcher In reed switch and the magnet. The distance should be a maximum of 1/8 inch (3 mm). If it is within the suggested range then the reed switch needs to be replaced.
- If the Left Fetcher cylinder is partially retracted,
 - Check that a foreign object is not preventing the Left Fetcher cylinder from retracting.
 - Electric power or hydraulic power or hydraulic return has been disconnected or shut off from machine.
 - Remove and observe the Fetcher check valve. If the snap ring in the bottom of the check valve is missing then the check valve needs to be replaced. If you are unable to push the plunger from the end of the check valve in and it spring back, then the check valve needs to be replaced.
- If the Left Fetcher cylinder is still extended,
 - Check that hydraulic power is still on to the machine and that return line is still connected.
 - Check that a foreign object is not preventing the Left Fetcher cylinder from retracting.
 - Remove and observe the Fetcher check valve. If the snap ring in the bottom of the check valve is missing then the check valve needs to be replaced. If you are unable to push the plunger from the end of the check valve in and it spring back, then the check valve needs to be replaced.
 - Check that the directional valve is not stuck.

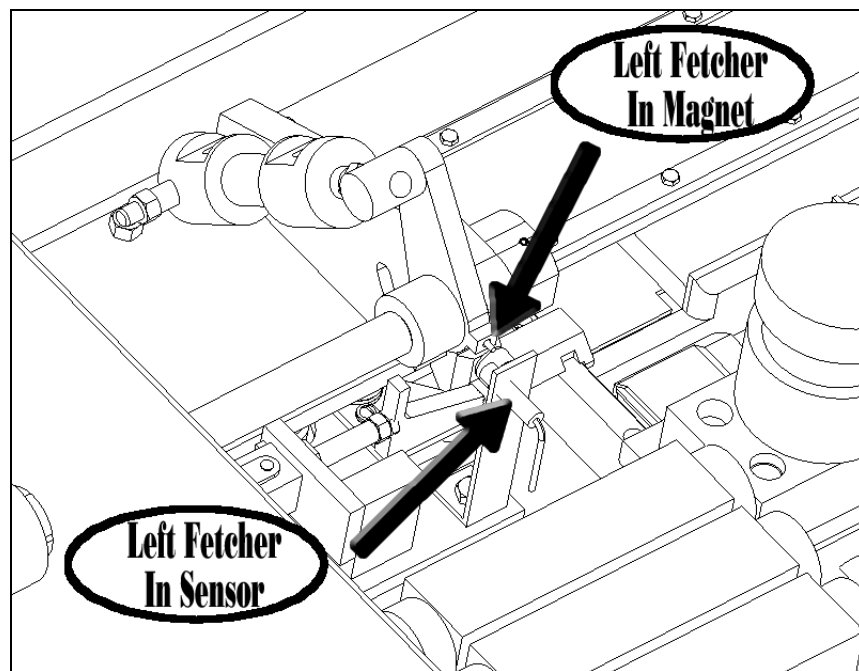
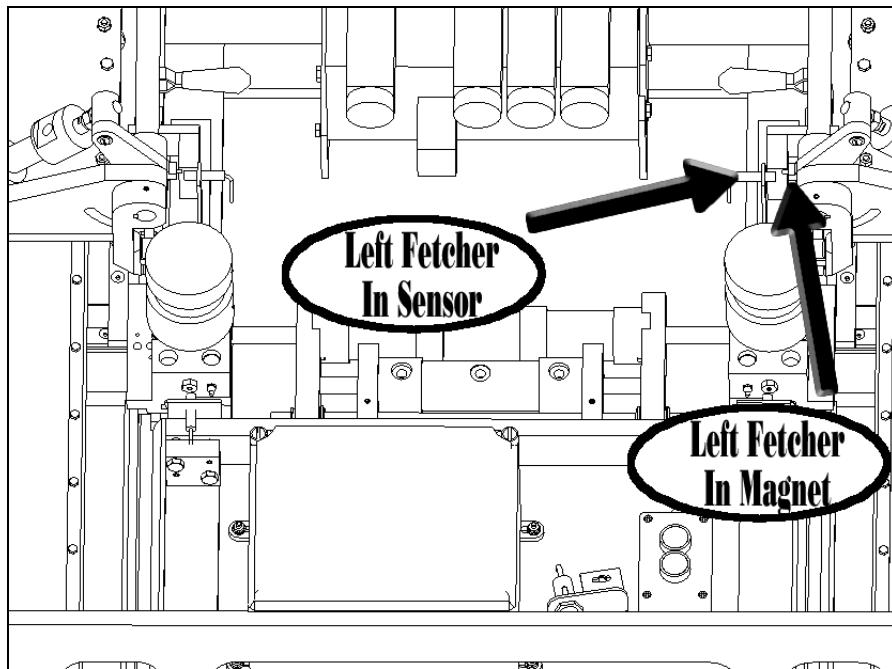

059 Waiting for Right Fetcher In reed switch to be on.

Note: After the machine has retracted the Right/Left Fetcher cylinder, the Right Fetcher In reed switch should be lined up with the Right Fetcher magnet, which turns the switch on. This is what the machine is waiting for.

- If the Right Fetcher cylinder is fully retracted,
 - Check the air gap distance between the Right Fetcher In reed switch and the magnet. The distance should be a maximum of 1/8 inch (3 mm). If it is within the suggested range then the reed switch needs to be replaced.
- If the Right Fetcher cylinder is partially retracted,
 - Check that a foreign object is not preventing the Right Fetcher cylinder from retracting.
 - Electric power or hydraulic power or hydraulic return has been disconnected or shut off from machine.

- Remove and observe the Fetcher check valve. If the snap ring in the bottom of the check valve is missing then the check valve needs to be replaced. If you are unable to push the plunger from the end of the check valve in and it spring back, then the check valve needs to be replaced.
- If the Right Fetcher cylinder is still extended,
 - Check that hydraulic power is still on to the machine and that return line is still connected.
 - Check that a foreign object is not preventing the Right Fetcher cylinder from retracting.
 - Remove and observe the Fetcher check valve. If the snap ring in the bottom of the check valve is missing then the check valve needs to be replaced. If you are unable to push the plunger from the end of the check valve in and it spring back, then the check valve needs to be replaced.
 - Check that the directional valve is not stuck.

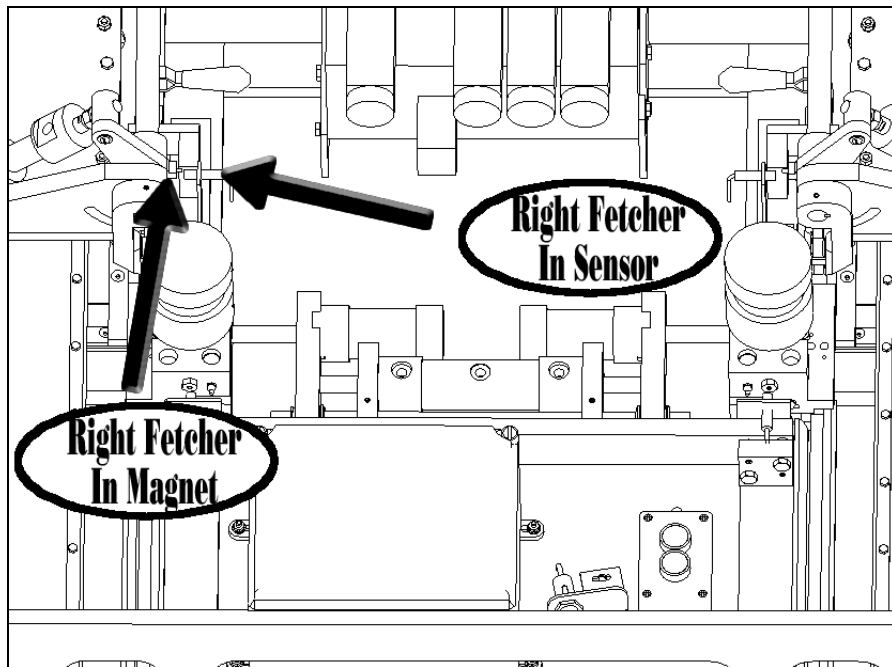

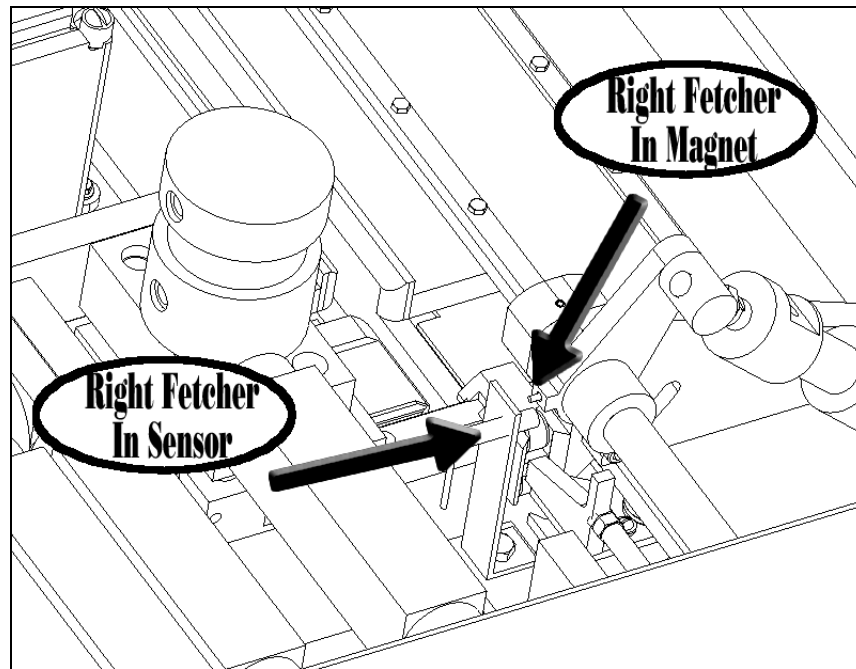

- 060 **Timer Delay Error**
 - Disengage hydraulic power and unplug main power cord. Wait for approximately 10 seconds, plug back in and engage hydraulic power.
- 061 **Timer Delay Error**
 - Disengage hydraulic power and unplug main power cord. Wait for approximately 10 seconds, plug back in and engage hydraulic power.
- 062 **Communication from Band Computer**
 - Disengage hydraulic power and unplug main power cord. Wait for approximately 10 seconds, plug back in and engage hydraulic power.
 - On Line 3 of Display Monitor, if the number after the dash is 0, then disconnect main electrical and hydraulic power. Open the plastic computer box in the banding box and unplug the two 10 amp fuses. Reconnect main electrical power only. Wait approximately 10 seconds and then reinstall the two 10 amp fuses at the same time. Recheck number on Line 3 after the dash, it should then be 1. Apply hydraulics.
- 063 **Communication from Band Computer**
 - Disengage hydraulic power and unplug main power cord. Wait for approximately 10 seconds, plug back in and engage hydraulic power.
 - On Line 3 of Display Monitor, if the number after the dash is 0, then disconnect main electrical and hydraulic power. Open the plastic computer box in the banding box and unplug the two 10 amp fuses. Reconnect main electrical power only. Wait approximately 10 seconds and then reinstall the two 10 amp fuses at the same time. Recheck number on Line 3 after the dash, it should then be 1. Apply hydraulics.
- 064 **Waiting for Left Band Out reed switch to be on.**
 Note: After the machine has extended the Right/Left Full Band cylinders, the Left Band Out reed switch should be lined up with the Left Band magnet, which turns the switch on. This is what the machine is waiting for.
 - If the Left Band Full cylinder is fully extended,

- Check the air gap distance between the Left Band Out reed switch and the magnet. The distance should be a maximum of 1/8 inch (3 mm). If it is within the suggested range then the reed switch needs to be replaced.
- If the Left Band Full cylinder is partially extended,
 - Check that a foreign object is not preventing the Left Band Full cylinder from extending.
 - Electric power or hydraulic power or hydraulic return has been disconnected or shut off from machine.
 - Remove and observe all 4 Band Position check valves. If the snap ring in the bottom of the check valve is missing then the check valve needs to be replaced. If you are unable to push the plunger from the end of the check valve in and it spring back, then the check valve needs to be replaced.
- If the Left Band Full cylinder is still retracted,
 - Check that hydraulic power is still on to the machine and that return line is still connected.
 - Check that a foreign object is not preventing the Left Band Full cylinder from extending.
 - Remove and observe all 4 Band Position check valves. If the snap ring in the bottom of the check valve is missing then the check valve needs to be replaced. If you are unable to push the plunger from the end of the check valve in and it spring back, then the check valve needs to be replaced.
 - Check that the directional valve is not stuck.

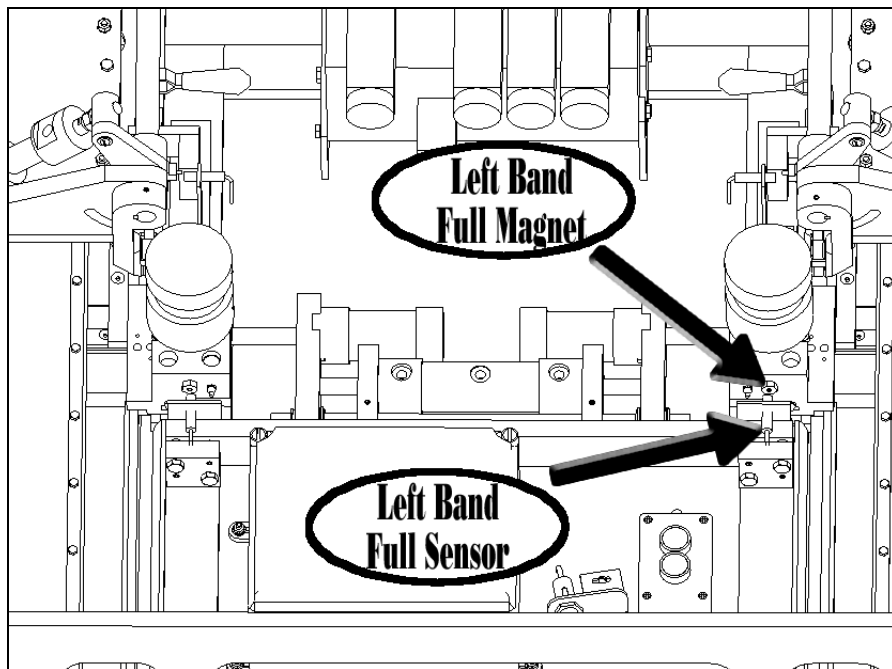

065 Waiting for Right Band Out reed switch to be on.

Note: After the machine has extended the Right/Left Full Band cylinders, the Right Band Out reed switch should be lined up with the Right Band magnet, which turns the switch on. This is what the machine is waiting for.

- If the Right Band Full cylinder is fully extended,
 - Check the air gap distance between the Right Band Out reed switch and the magnet. The distance should be a maximum of 1/8 inch (3 mm). If it is within the suggested range then the reed switch needs to be replaced.
- If the Right Band Full cylinder is partially extended,

- Check that a foreign object is not preventing the Right Band Full cylinder from extending.
- Electric power or hydraulic power or hydraulic return has been disconnected or shut off from machine.
- Remove and observe all 4 Band Position check valves. If the snap ring in the bottom of the check valve is missing then the check valve needs to be replaced. If you are unable to push the plunger from the end of the check valve in and it spring back, then the check valve needs to be replaced.
- If the Right Band Full cylinder is still retracted,
 - Check that hydraulic power is still on to the machine and that return line is still connected.
 - Check that a foreign object is not preventing the Right Band Full cylinder from extending.
 - Remove and observe all 4 Band Position check valves. If the snap ring in the bottom of the check valve is missing then the check valve needs to be replaced. If you are unable to push the plunger from the end of the check valve in and it spring back, then the check valve needs to be replaced.
 - Check that the directional valve is not stuck.

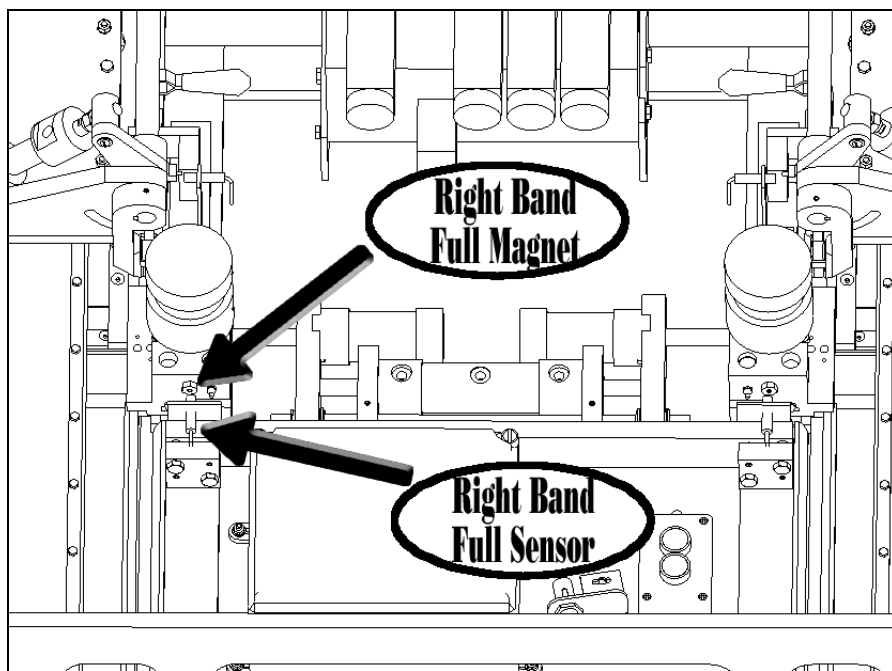

066 Timer Delay Error

- Disengage hydraulic power and unplug main power cord. Wait for approximately 10 seconds, plug back in and engage hydraulic power.

067 Communication from Band Computer

- Disengage hydraulic power and unplug main power cord. Wait for approximately 10 seconds, plug back in and engage hydraulic power.
- On Line 3 of Display Monitor, if the number after the dash is 0, then disconnect main electrical and hydraulic power. Open the plastic computer box in the banding box and unplug the two 10 amp fuses. Reconnect main electrical power only. Wait approximately 10 seconds and then reinstall the two 10 amp fuses at the same time. Recheck number on Line 3 after the dash, it should then be 1. Apply hydraulics.

068 Waiting for Left Band Out reed switch to be off.

Note: After the machine lowers the Right/Left Bander cylinders it checks to see if they are down by making sure that the Left Band Out reed switch is off. When the Bander cylinders go down it moves the Bander magnets down with it. This removes the magnet away from the Left Band Out reed switch, turning the reed switch off. This is what the machine is waiting for.

- If the Left Bander cylinder is fully retracted,
 - Loosen nuts on Left Band Out reed switch and hold the switch away from any magnets or metal for approximately 10 seconds. Check tractor box display to see if it is still displays “068”. If it does, lightly tap the switch on something to free up the stuck switch. The switch may need to be replaced if this problem continues.
- If the Left Bander cylinder is partially retracted,
 - Check that a foreign object is not preventing the Left Bander cylinder from retracting.
 - Electric power or hydraulic power or hydraulic return has been disconnected or shut off from machine.
- If the Left Bander cylinder is still extended,
 - Check that hydraulic power is still on to the machine and that return line is still connected.
 - Check that a foreign object is not preventing the Left Bander cylinder from retracting.
 - Check that the directional valve is not stuck.

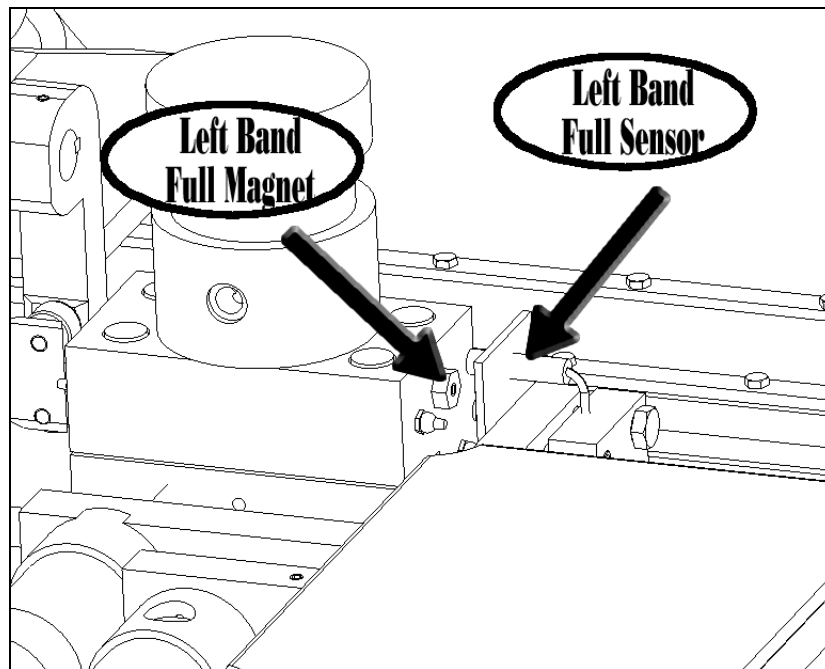

069 Waiting for Right Band Out reed switch to be off.

Note: After the machine lowers the Right/Left Bander cylinders it checks to see if they are down by making sure that the Right Band Out reed switch is off. When the Bander cylinders go down it moves the Bander magnets down with it. This removes the magnet away from the Right Band Out reed switch, turning the reed switch off. This is what the machine is waiting for.

- If the Right Bander cylinder is fully retracted,
 - Loosen nuts on Right Band Out reed switch and hold the switch away from any magnets or metal for approximately 10 seconds. Check tractor box display to see if it

- is still displays “069”. If it does, lightly tap the switch on something to free up the stuck switch. The switch may need to be replaced if this problem continues.
- If the Right Bander cylinder is partially retracted,
 - Check that a foreign object is not preventing the Right Bander cylinder from retracting.
 - Electric power or hydraulic power or hydraulic return has been disconnected or shut off from machine.
 - If the Right Bander cylinder is still extended,
 - Check that hydraulic power is still on to the machine and that return line is still connected.
 - Check that a foreign object is not preventing the Right Bander cylinder from retracting.
 - Check that the directional valve is not stuck.

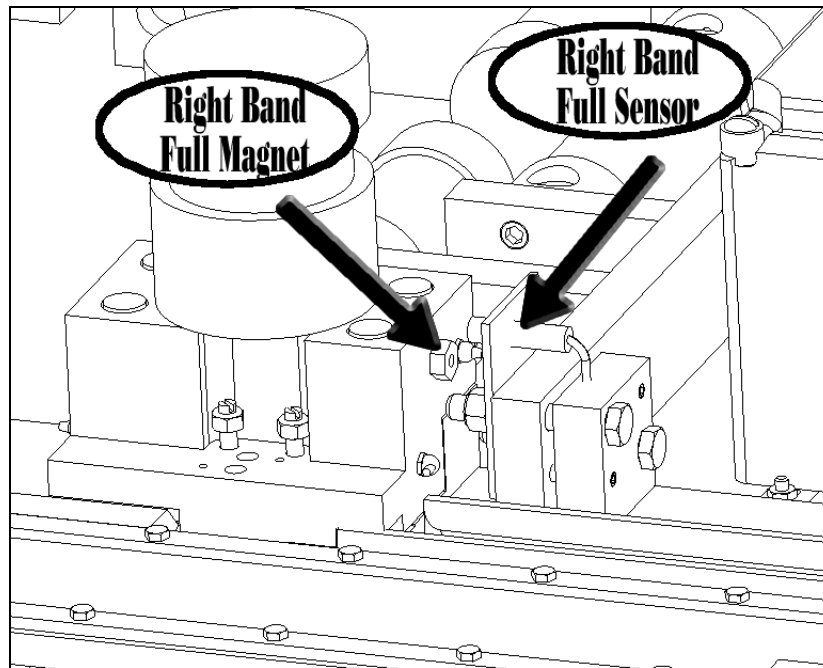

070 Timer Delay Error

- Disengage hydraulic power and unplug main power cord. Wait for approximately 10 seconds, plug back in and engage hydraulic power.

071 Communication from Band Computer

- Disengage hydraulic power and unplug main power cord. Wait for approximately 10 seconds, plug back in and engage hydraulic power.
- On Line 3 of Display Monitor, if the number after the dash is 0, then disconnect main electrical and hydraulic power. Open the plastic computer box in the banding box and unplug the two 10 amp fuses. Reconnect main electrical power only. Wait approximately 10 seconds and then reinstall the two 10 amp fuses at the same time. Recheck number on Line 3 after the dash, it should then be 1. Apply hydraulics.

072 Waiting for Left Band Out reed switch to be on.

Note: After the machine has raised the Right/Left Bander cylinders, the Left Band Out reed switch should be lined up with the Left Band magnet, which turns the switch on. This is what the machine is waiting for.

- If the Left Bander cylinder is fully extended,

- Check the air gap distance between the Left Band Out reed switch and the magnet. The distance should be a maximum of 1/8 inch (3 mm). If it is within the suggested range then the reed switch needs to be replaced.
- If the Left Bander cylinder is partially extended,
 - Check that a foreign object is not preventing the Left Bander cylinder from extending.
 - Electric power or hydraulic power or hydraulic return has been disconnected or shut off from machine.
- If the Left Bander cylinder is still retracted,
 - Check that hydraulic power is still on to the machine and that return line is still connected.
 - Check that a foreign object is not preventing the Left Bander cylinder from extending.
 - Check that the directional valve is not stuck.

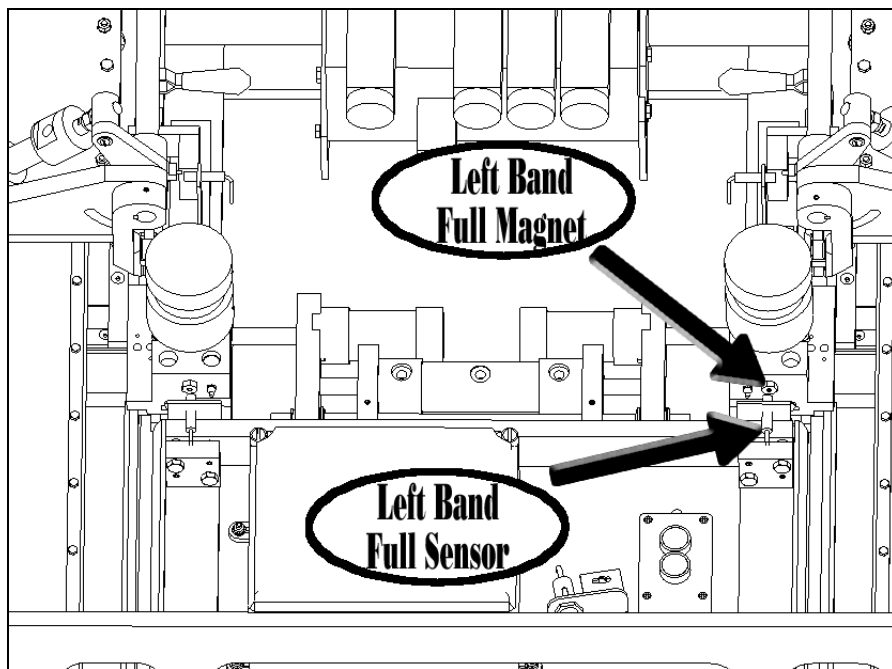

073 Waiting for Right Band Out reed switch to be on. .

Note: After the machine has raised the Right/Left Bander cylinders, the Right Band Out reed switch should be lined up with the Right Band magnet, which turns the switch on. This is what the machine is waiting for.

- If the Right Bander cylinder is fully extended,
 - Check the air gap distance between the Right Band Out reed switch and the magnet. The distance should be a maximum of 1/8 inch (3 mm). If it is within the suggested range then the reed switch needs to be replaced.
- If the Right Bander cylinder is partially extended,
 - Check that a foreign object is not preventing the Right Bander cylinder from extending.
 - Electric power or hydraulic power or hydraulic return has been disconnected or shut off from machine.
- If the Right Bander cylinder is still retracted,
 - Check that hydraulic power is still on to the machine and that return line is still connected.

- Check that a foreign object is not preventing the Right Bander cylinder from extending.
- Check that the directional valve is not stuck.

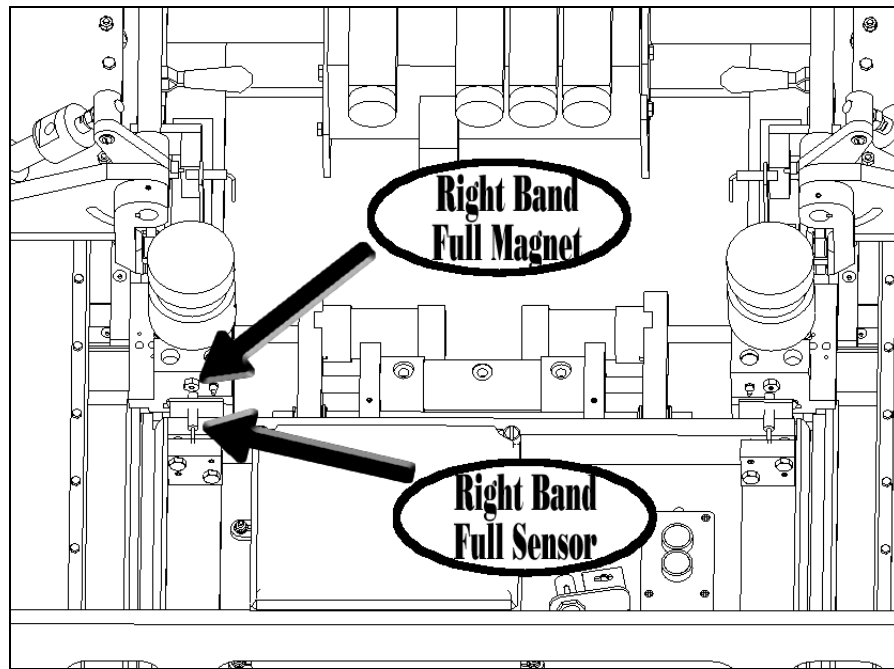

074 Timer Delay Error

- Disengage hydraulic power and unplug main power cord. Wait for approximately 10 seconds, plug back in and engage hydraulic power.

075 Communication from Band Computer

- Disengage hydraulic power and unplug main power cord. Wait for approximately 10 seconds, plug back in and engage hydraulic power.
- On Line 3 of Display Monitor, if the number after the dash is 0, then disconnect main electrical and hydraulic power. Open the plastic computer box in the banding box and unplug the two 10 amp fuses. Reconnect main electrical power only. Wait approximately 10 seconds and then reinstall the two 10 amp fuses at the same time. Recheck number on Line 3 after the dash, it should then be 1. Apply hydraulics.

076 Communication from Band Computer

- Disengage hydraulic power and unplug main power cord. Wait for approximately 10 seconds, plug back in and engage hydraulic power.
- On Line 3 of Display Monitor, if the number after the dash is 0, then disconnect main electrical and hydraulic power. Open the plastic computer box in the banding box and unplug the two 10 amp fuses. Reconnect main electrical power only. Wait approximately 10 seconds and then reinstall the two 10 amp fuses at the same time. Recheck number on Line 3 after the dash, it should then be 1. Apply hydraulics.

077 Timer Delay Error

- Disengage hydraulic power and unplug main power cord. Wait for approximately 10 seconds, plug back in and engage hydraulic power.

078 Communication from Band Computer

- Disengage hydraulic power and unplug main power cord. Wait for approximately 10 seconds, plug back in and engage hydraulic power.
- On Line 3 of Display Monitor, if the number after the dash is 0, then disconnect main electrical and hydraulic power. Open the plastic computer box in the banding box and unplug the two 10 amp fuses. Reconnect main electrical power only. Wait approximately 10 seconds and then reinstall the two 10 amp fuses at the same time. Recheck number on Line 3 after the dash, it should then be 1. Apply hydraulics.

079 Communication from Band Computer

- Disengage hydraulic power and unplug main power cord. Wait for approximately 10 seconds, plug back in and engage hydraulic power.
- On Line 3 of Display Monitor, if the number after the dash is 0, then disconnect main electrical and hydraulic power. Open the plastic computer box in the banding box and unplug the two 10 amp fuses. Reconnect main electrical power only. Wait approximately 10 seconds and then reinstall the two 10 amp fuses at the same time. Recheck number on Line 3 after the dash, it should then be 1. Apply hydraulics.

080 Communication from Band Computer

- Disengage hydraulic power and unplug main power cord. Wait for approximately 10 seconds, plug back in and engage hydraulic power.
- On Line 3 of Display Monitor, if the number after the dash is 0, then disconnect main electrical and hydraulic power. Open the plastic computer box in the banding box and unplug the two 10 amp fuses. Reconnect main electrical power only. Wait approximately 10 seconds and then reinstall the two 10 amp fuses at the same time. Recheck number on Line 3 after the dash, it should then be 1. Apply hydraulics.

081 Communication from Band Computer

- Disengage hydraulic power and unplug main power cord. Wait for approximately 10 seconds, plug back in and engage hydraulic power.
- On Line 3 of Display Monitor, if the number after the dash is 0, then disconnect main electrical and hydraulic power. Open the plastic computer box in the banding box and unplug the two 10 amp fuses. Reconnect main electrical power only. Wait approximately 10 seconds and then reinstall the two 10 amp fuses at the same time. Recheck number on Line 3 after the dash, it should then be 1. Apply hydraulics.

082 Communication from Band Computer

- Disengage hydraulic power and unplug main power cord. Wait for approximately 10 seconds, plug back in and engage hydraulic power.
- On Line 3 of Display Monitor, if the number after the dash is 0, then disconnect main electrical and hydraulic power. Open the plastic computer box in the banding box and unplug the two 10 amp fuses. Reconnect main electrical power only. Wait approximately 10 seconds and then reinstall the two 10 amp fuses at the same time. Recheck number on Line 3 after the dash, it should then be 1. Apply hydraulics.

083 Communication from Band Computer

- Disengage hydraulic power and unplug main power cord. Wait for approximately 10 seconds, plug back in and engage hydraulic power.
- On Line 3 of Display Monitor, if the number after the dash is 0, then disconnect main electrical and hydraulic power. Open the plastic computer box in the banding box and unplug the two 10 amp fuses. Reconnect main electrical power only. Wait

approximately 10 seconds and then reinstall the two 10 amp fuses at the same time. Recheck number on Line 3 after the dash, it should then be 1. Apply hydraulics.

084 Waiting for Left Fetcher Out reed switch to be on.

Note: This code occurs when the Reset Bundle button was pressed while the Fetcher cylinders were extended or partially extended. In order to properly reset, the machine will fully extend the Fetcher cylinders (unless they are already extended). The machine will then wait until the Left Fetcher magnet is in front of the Left Fetcher Out reed switch.

- If the Left Fetcher cylinder is fully extended,
 - Check the air gap distance between the Left Fetcher Out reed switch and the magnet. The distance should be a maximum of 1/8 inch (3 mm). If it is within the suggested range then the reed switch needs to be replaced.
- If the Left Fetcher cylinder is partially extended,
 - Check that a foreign object is not preventing the Left Fetcher cylinder from extending.
 - Electric power or hydraulic power or hydraulic return has been disconnected or shut off from machine.
 - Remove and observe the Fetcher check valve. If the snap ring in the bottom of the check valve is missing then the check valve needs to be replaced. If you are unable to push the plunger from the end of the check valve in and it spring back, then the check valve needs to be replaced.
- If the Left Fetcher cylinder is still retracted,
 - Check that hydraulic power is still on to the machine and that return line is still connected.
 - Check that a foreign object is not preventing the Left Fetcher cylinder from extending.
 - Remove and observe the Fetcher check valve. If the snap ring in the bottom of the check valve is missing then the check valve needs to be replaced. If you are unable to push the plunger from the end of the check valve in and it spring back, then the check valve needs to be replaced.
 - Check that the directional valve is not stuck.

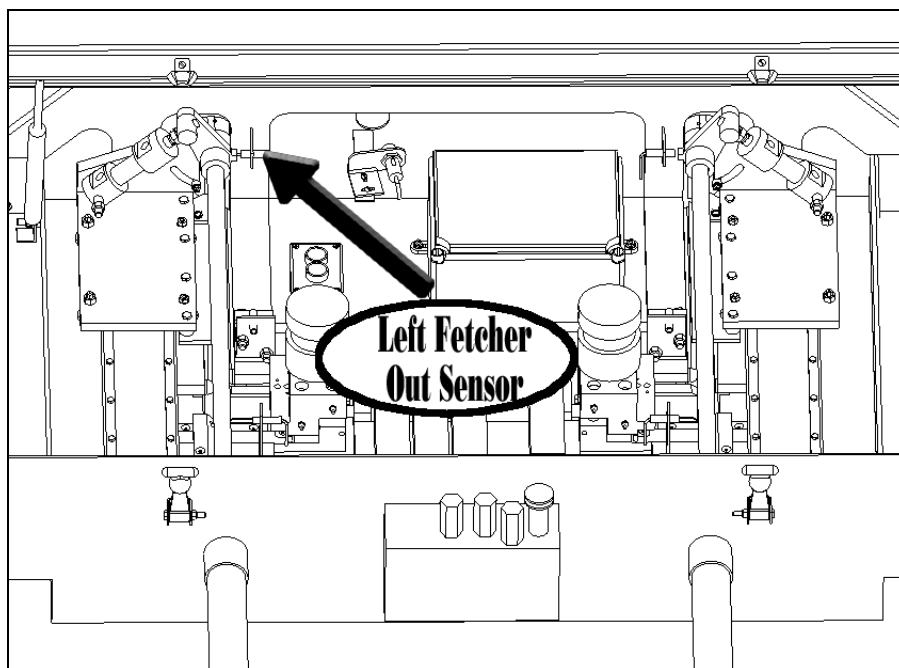

085 Waiting for Right Fetcher Out reed switch to be on.

Note: This code occurs when the Reset Bundle button was pressed while the Fetcher cylinders were extended or partially extended. In order to properly reset, the machine will fully extend the Fetcher cylinders (unless they are already extended). The machine will then wait until the Right Fetcher magnet is in front of the Right Fetcher Out reed switch.

- If the Right Fetcher cylinder is fully extended,
 - Check the air gap distance between the Right Fetcher Out reed switch and the magnet. The distance should be a maximum of 1/8 inch (3 mm). If it is within the suggested range then the reed switch needs to be replaced.
- If the Right Fetcher cylinder is partially extended,
 - Check that a foreign object is not preventing the Right Fetcher cylinder from extending.
 - Electric power or hydraulic power or hydraulic return has been disconnected or shut off from machine.
 - Remove and observe the Fetcher check valve. If the snap ring in the bottom of the check valve is missing then the check valve needs to be replaced. If you are unable to push the plunger from the end of the check valve in and it spring back, then the check valve needs to be replaced.
- If the Right Fetcher cylinder is still retracted,
 - Check that hydraulic power is still on to the machine and that return line is still connected.
 - Check that a foreign object is not preventing the Right Fetcher cylinder from extending.
 - Remove and observe the Fetcher check valve. If the snap ring in the bottom of the check valve is missing then the check valve needs to be replaced. If you are unable to push the plunger from the end of the check valve in and it spring back, then the check valve needs to be replaced.
 - Check that the directional valve is not stuck.

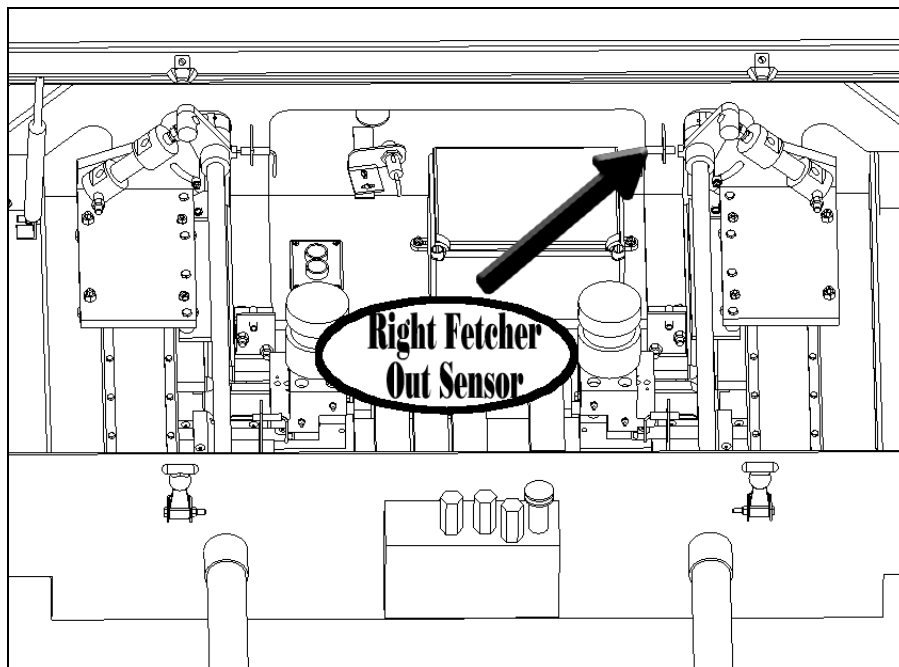

086 Communication from Band Computer

- Disengage hydraulic power and unplug main power cord. Wait for approximately 10 seconds, plug back in and engage hydraulic power.
- On Line 3 of Display Monitor, if the number after the dash is 0, then disconnect main electrical and hydraulic power. Open the plastic computer box in the banding box and unplug the two 10 amp fuses. Reconnect main electrical power only. Wait approximately 10 seconds and then reinstall the two 10 amp fuses at the same time. Recheck number on Line 3 after the dash, it should then be 1. Apply hydraulics.

087 Waiting for Left Fetcher In reed switch to be on.

Note: This code occurs after the Reset Bundle button has been pressed. After the machine has retracted the Right/Left Fetcher cylinder, the Left Fetcher In reed switch should be lined up with the Left Fetcher magnet, which turns the switch on. This is what the machine is waiting for.

- If the Left Fetcher cylinder is fully retracted,
 - Check the air gap distance between the Left Fetcher In reed switch and the magnet. The distance should be a maximum of 1/8 inch (3 mm). If it is within the suggested range then the reed switch needs to be replaced.
- If the Left Fetcher cylinder is partially retracted,
 - Check that a foreign object is not preventing the Left Fetcher cylinder from retracting.
 - Electric power or hydraulic power or hydraulic return has been disconnected or shut off from machine.
 - Remove and observe the Fetcher check valve. If the snap ring in the bottom of the check valve is missing then the check valve needs to be replaced. If you are unable to push the plunger from the end of the check valve in and it spring back, then the check valve needs to be replaced.
- If the Left Fetcher cylinder is still extended,
 - Check that hydraulic power is still on to the machine and that return line is still connected.
 - Check that a foreign object is not preventing the Left Fetcher cylinder from retracting.
 - Remove and observe the Fetcher check valve. If the snap ring in the bottom of the check valve is missing then the check valve needs to be replaced. If you are unable to push the plunger from the end of the check valve in and it spring back, then the check valve needs to be replaced.
 - Check that the directional valve is not stuck.

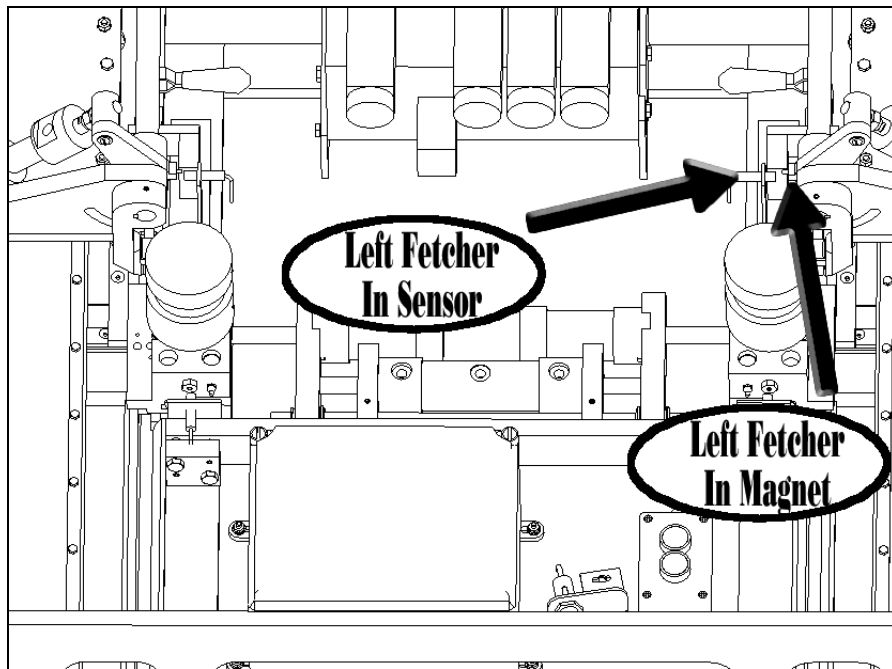

088 Waiting for Right Fetcher In reed switch to be on.

Note: This code occurs after the Reset Bundle button has been pressed. After the machine has retracted the Right/Left Fetcher cylinder, the Right Fetcher In reed switch should be lined up with the Right Fetcher magnet, which turns the switch on. This is what the machine is waiting for.

- If the Right Fetcher cylinder is fully retracted,
 - Check the air gap distance between the Right Fetcher In reed switch and the magnet. The distance should be a maximum of 1/8 inch (3 mm). If it is within the suggested range then the reed switch needs to be replaced.
- If the Right Fetcher cylinder is partially retracted,
 - Check that a foreign object is not preventing the Right Fetcher cylinder from retracting.
 - Electric power or hydraulic power or hydraulic return has been disconnected or shut off from machine.
 - Remove and observe the Fetcher check valve. If the snap ring in the bottom of the check valve is missing then the check valve needs to be replaced. If you are unable to push the plunger from the end of the check valve in and it spring back, then the check valve needs to be replaced.
- If the Right Fetcher cylinder is still extended,
 - Check that hydraulic power is still on to the machine and that return line is still connected.
 - Check that a foreign object is not preventing the Right Fetcher cylinder from retracting.
 - Remove and observe the Fetcher check valve. If the snap ring in the bottom of the check valve is missing then the check valve needs to be replaced. If you are unable to push the plunger from the end of the check valve in and it spring back, then the check valve needs to be replaced.
 - Check that the directional valve is not stuck.

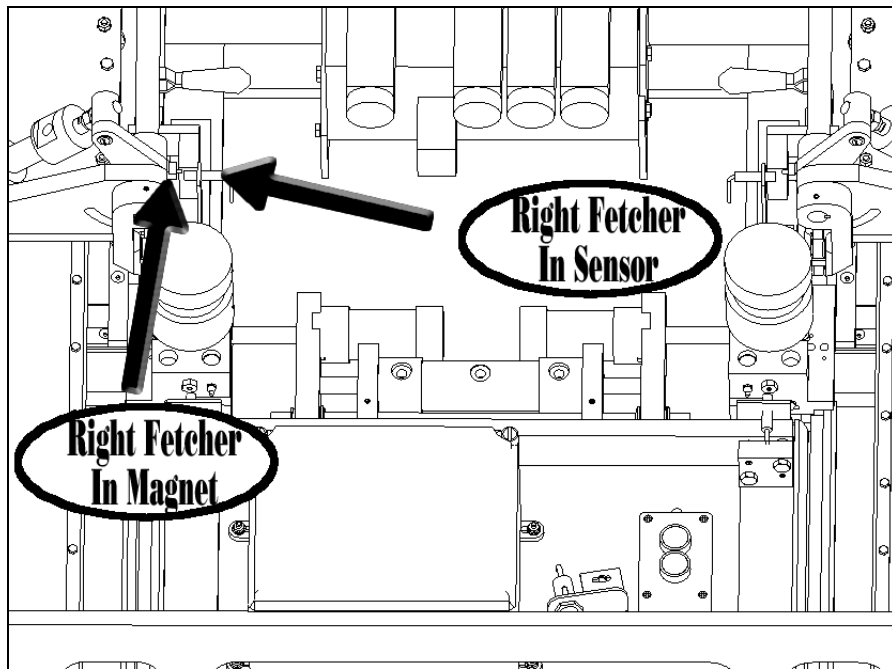

089 Waiting for Kicker reed switch to be on.

Note: This code occurs after the Reset Bundle button has been pressed. After the machine has retracted the Kicker cylinder, the Kicker reed switch should be lined up with the Kicker magnet located in the round plastic, which turns the switch on. This is what the machine is waiting for.

If the Kicker cylinder is fully retracted,

- Check the air gap distance between the Kicker reed switch and the magnet. The distance should be a maximum of 3/8 inch (9 mm). If it is within the suggested range then the reed switch needs to be replaced.

If the Kicker cylinder is partially retracted,

- Check that a bale or foreign object is not preventing the Kicker from retracting.
- Hydraulic power or hydraulic return has been disconnected or shut off from machine. This circuit has a 2-position valve and cannot be partially extended unless power or return has been disconnected or shut off.

If the Kicker cylinder is still extended,

- Check that hydraulic power is still on to the machine and that return line is still connected.
- Check that a bale or foreign object is not preventing the Kicker from retracting.
- Check that the directional valve is not stuck.

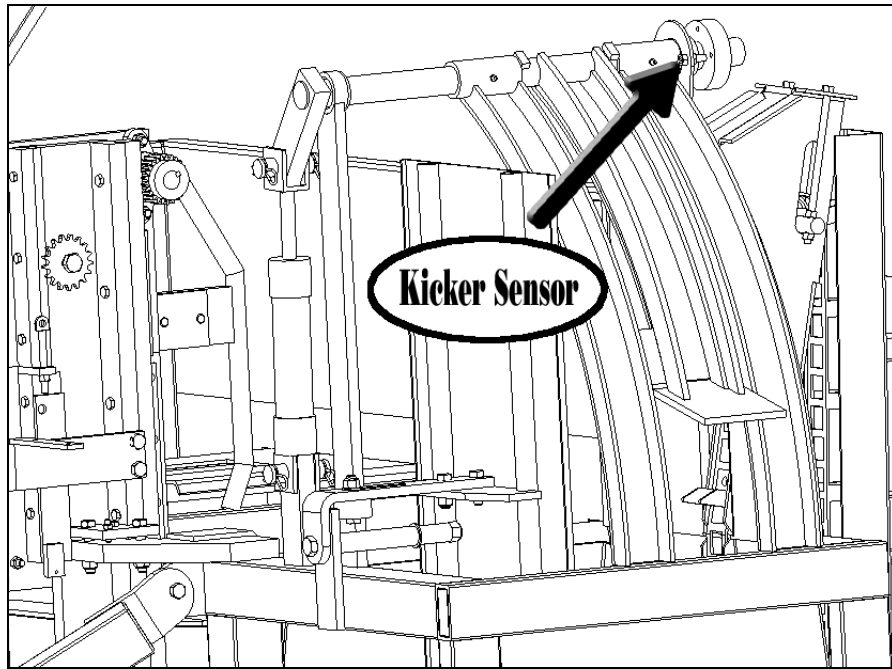

090 Waiting for Horizontal Plunger reed switch to be on.

Note: This code occurs after the Reset Bundle button has been pressed. After the machine has extended the Horizontal Plunger cylinder, the Horizontal Plunger reed switch should be lined up with the Horizontal Plunger magnets, which turns the switch on. This is what the machine is waiting for.

If the Horizontal Plunger cylinder is fully extended,

- Check the air gap distance between the Horizontal Plunger reed switch and the magnet. The distance should be a maximum of 3/8 inch (9 mm). If it is within the suggested range then the reed switch needs to be replaced.

If the Horizontal Plunger cylinder is partially extended,

- Check that a bale or foreign object is not preventing the Horizontal Plunger cylinder from extending.
- Hydraulic power or hydraulic return has been disconnected or shut off from machine. This circuit has a 2-position valve and cannot be partially extended unless power or return has been disconnected or shut off.

If the Horizontal Plunger cylinder is still retracted,

- Check that hydraulic power is still on to the machine and that return line is still connected.
- Check that a bale or foreign object is not preventing the Horizontal Plunger cylinder from extending.
- Check that the directional valve is not stuck.

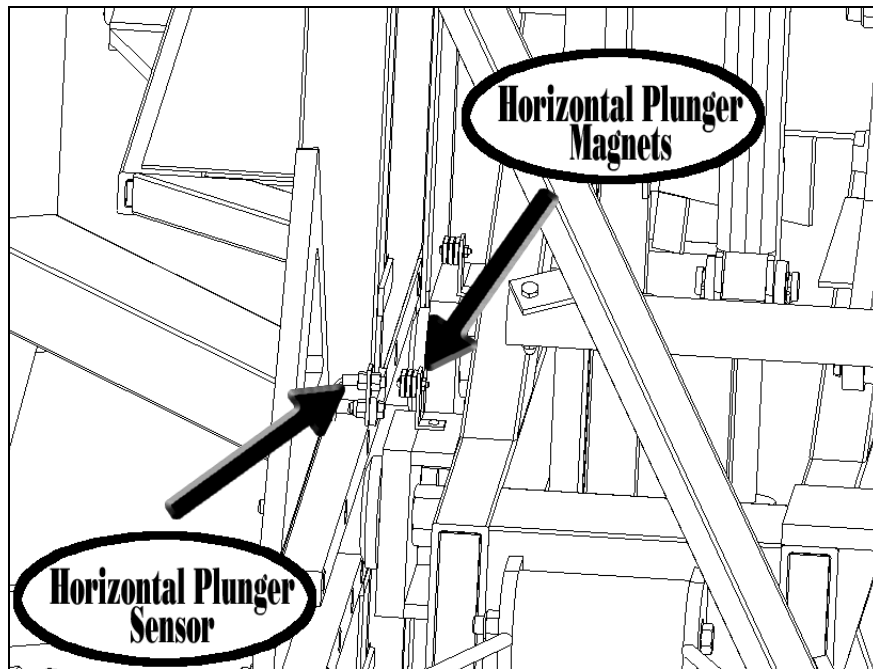

091 Communication from Band Computer

- Disengage hydraulic power and unplug main power cord. Wait for approximately 10 seconds, plug back in and engage hydraulic power.
- On Line 3 of Display Monitor, if the number after the dash is 0, then disconnect main electrical and hydraulic power. Open the plastic computer box in the banding box and unplug the two 10 amp fuses. Reconnect main electrical power only. Wait approximately 10 seconds and then reinstall the two 10 amp fuses at the same time. Recheck number on Line 3 after the dash, it should then be 1. Apply hydraulics.

092 Waiting for Strap Guides to be at top position.

Note: The machine has turned on the Strap Guide Arms motor and sent them up. When the Strap Guide Arms magnet reaches the Bale Position 0 sensor bar switch, the machine stops the motor. The machine is waiting for the magnet to reach the Bale Position 0 sensor bar switch. The switch is located upper mid way of the sensor bar at the brown mark.

- Check that Strap Guide Arms are in time with each other. They should be the same height. If their heights vary $\frac{1}{2}$ inch (12.5 mm) or greater then they are at least one gear tooth out of time. A quick way to check their heights is to compare the distance between the Vertical Plunger plates to the Strap Guide plates. The right side should be the same distance as the left side. In order to prevent the Strap Guide arms from getting out of time, keep their chains tight.
- Check that hydraulic power is still on to the machine and that return line is still connected.
- Check that a bale, excess hay or foreign object is not preventing the Strap Guide Arms from rising.
- Check that the directional valve is not stuck.

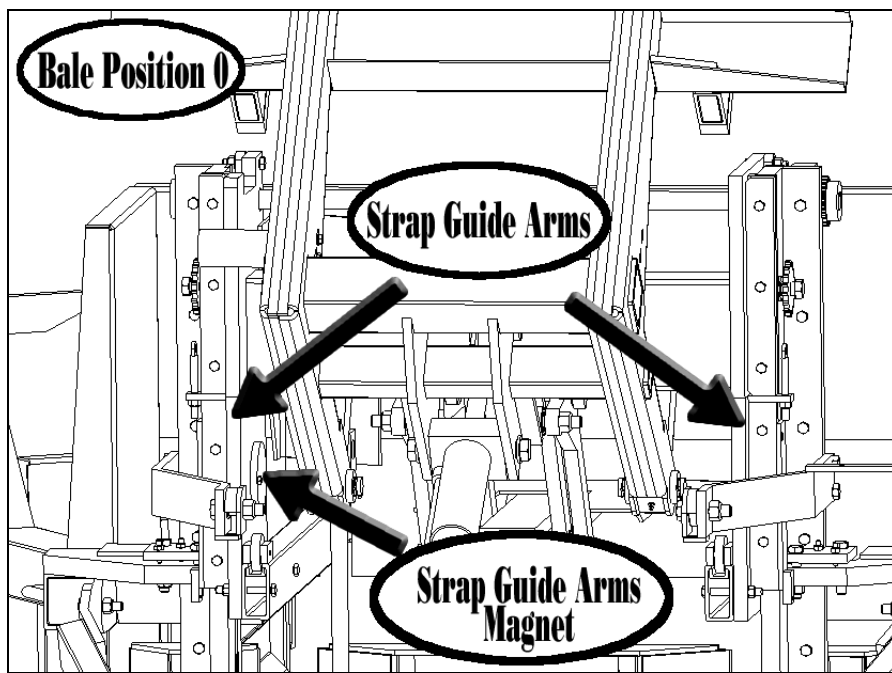
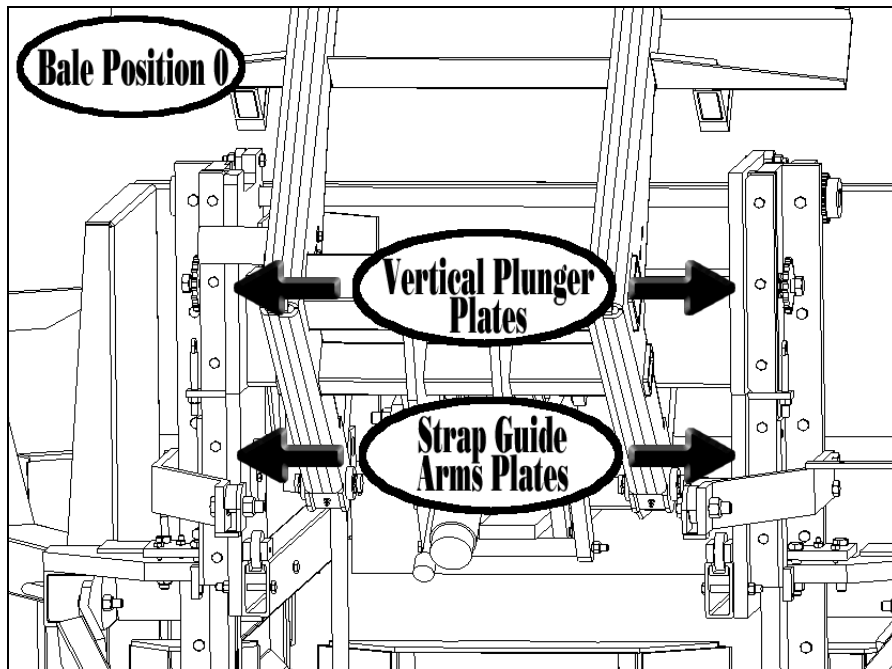

093 Communication from Band Computer

- Disengage hydraulic power and unplug main power cord. Wait for approximately 10 seconds, plug back in and engage hydraulic power.
- On Line 3 of Display Monitor, if the number after the dash is 0, then disconnect main electrical and hydraulic power. Open the plastic computer box in the banding box and unplug the two 10 amp fuses. Reconnect main electrical power only. Wait approximately 10 seconds and then reinstall the two 10 amp fuses at the same time. Recheck number on Line 3 after the dash, it should then be 1. Apply hydraulics.

094 Bale Position 0 sensor bar switch stuck on.

Note: Before the machine will raise the Strap Guide Arms, it does a safety check on the Bale Position 0 sensor bar switch. It checks to see if the sensor bar switch is stuck on. If

it is, it will wait until the sensor bar switch is off before continuing the operation. The switch is located upper mid way of the sensor bar at the brown mark.

- Tap on Bale Position 0 sensor bar switch until display number changes or replace the sensor bar.

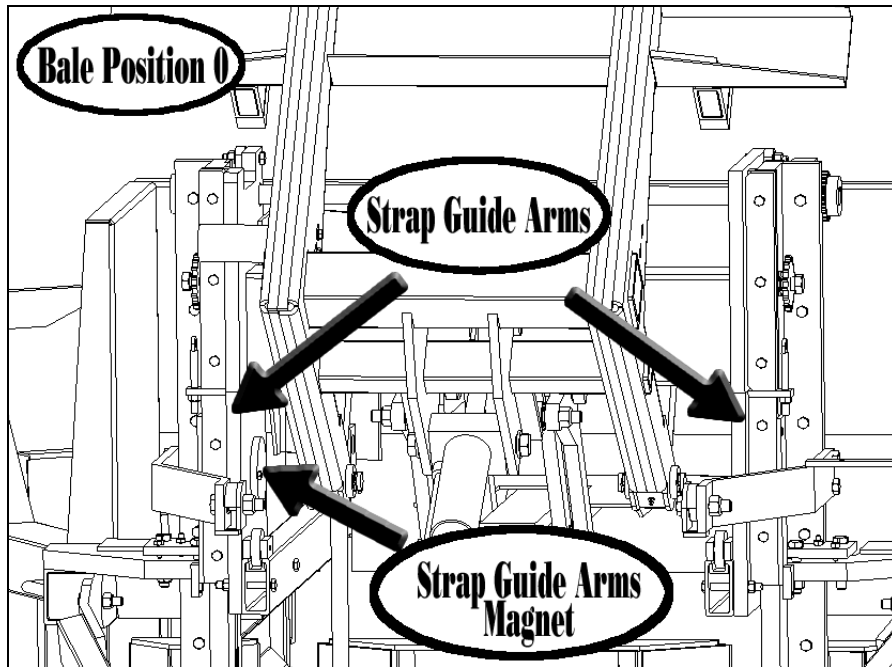

095 Bale Position 1 sensor bar switch stuck on.

Note: Before the machine will lower the Strap Guide Arms, it does a safety check on the Bale Position 1 sensor bar switch. It checks to see if the sensor bar switch is stuck on. If it is, it will wait until the sensor bar switch is off before continuing the operation. The switch is located mid way of the sensor bar at the green mark.

- Tap on Bale Position 1 sensor bar switch until display number changes or replace the sensor bar.

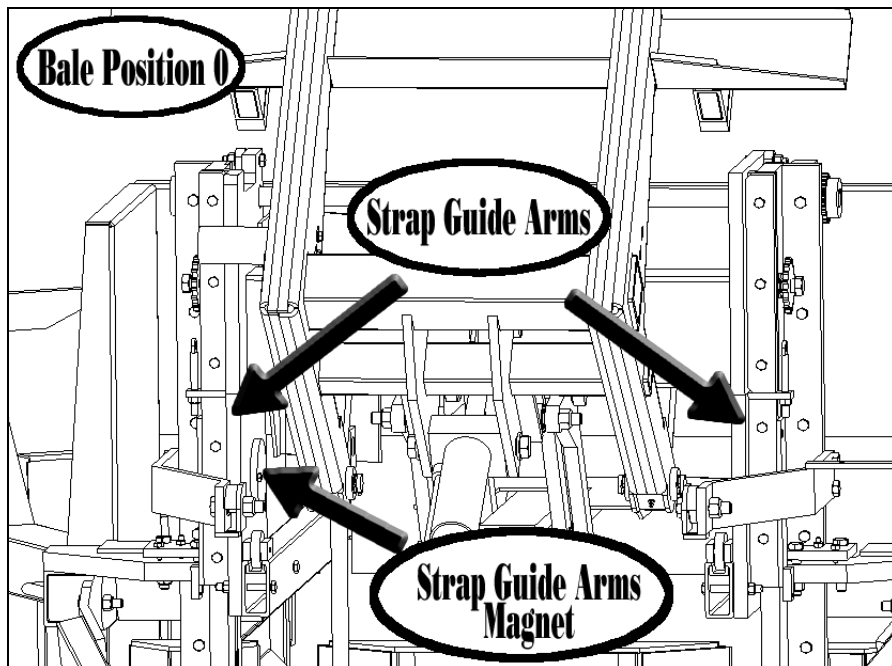

096 Bale Position 2 sensor bar switch stuck on.

Note: Before the machine will lower the Strap Guide Arms, it does a safety check on the Bale Position 2 sensor bar switch. It checks to see if the sensor bar switch is stuck on. If it is, it will wait until the sensor bar switch is off before continuing the operation. The switch is located lower mid way of the sensor bar at the blue mark.

- Tap on Bale Position 2 sensor bar switch until display number changes or replace the sensor bar.

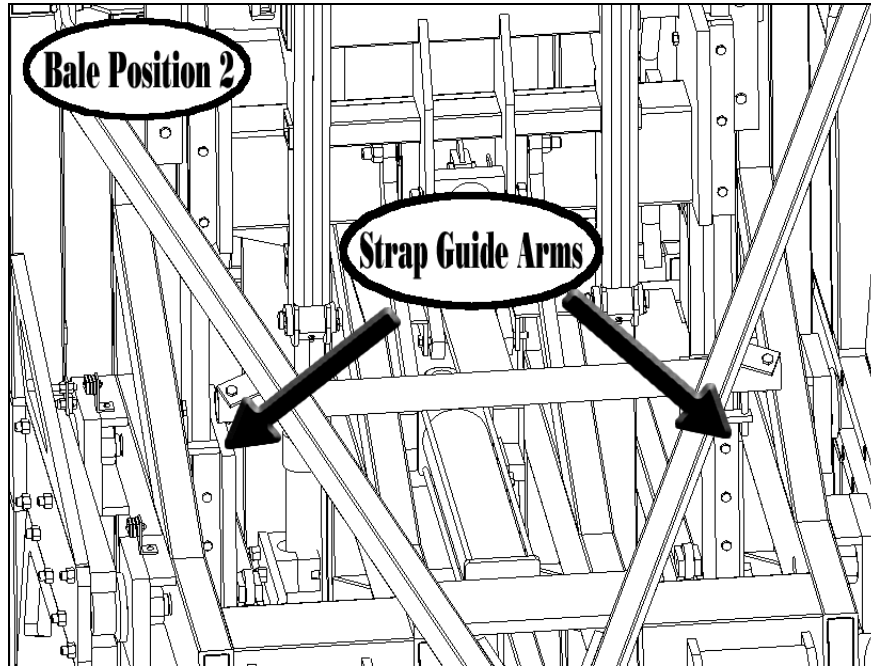

097 Bale Position 3 sensor bar switch stuck on.

Note: Before the machine will lower the Strap Guide Arms, it does a safety check on the Bale Position 3 sensor bar switch. It checks to see if the sensor bar switch is stuck on. If it is, it will wait until the sensor bar switch is off before continuing the operation. The switch is located at the bottom of the sensor bar at the yellow mark.

- Tap on Bale Position 3 sensor bar switch until display number changes or replace the sensor bar.

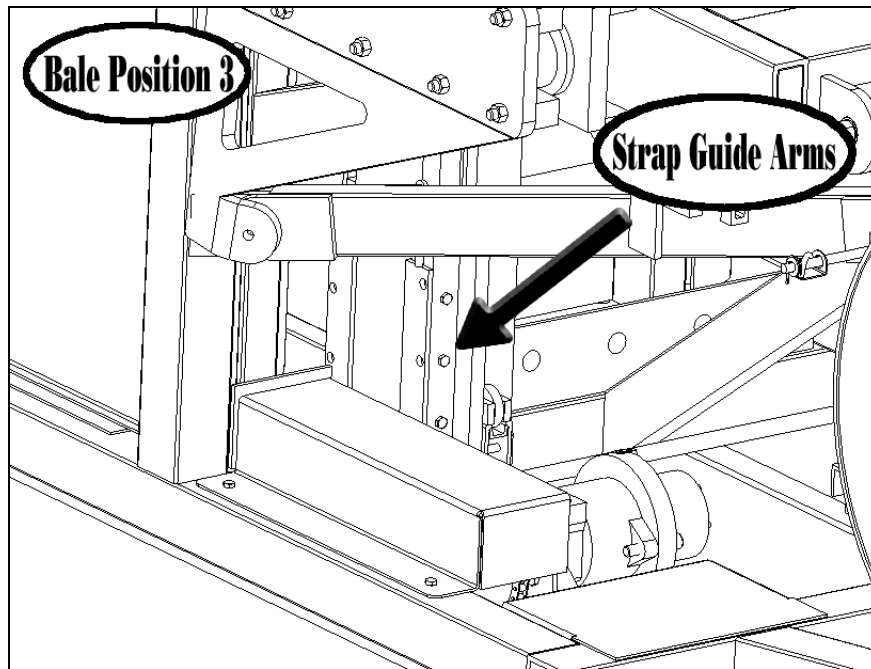

098 Computer Error

- Disengage hydraulic power and unplug main power cord. Wait for approximately 10 seconds, plug back in and engage hydraulic power. If this doesn't change the "098" code, then take out all bales in front chamber by opening the side doors. Once the bales are out, press the Reset Bundle button.

099 Out of Strapping

- The computer's bundle count has reached 0 bundles left on the current 2 rolls of strapping. In order for the machine to continue operating the Reset Banding button needs to be pressed, which is located in the Banding box. By pressing the Reset Banding button, the computer then thinks that 2 new rolls of strapping has been threaded into the machine. The bundle display count is reset to 122 and will begin down counting as soon as the first bale enters the machine.

100 Photo 1 Ready, Waiting for a Bale

- The machine is waiting for the baler to place a bale at Photo 1 located at the mouth of the elevator.

-Elevator will have the following state:

- Horizontal and Vertical elevator will be off.

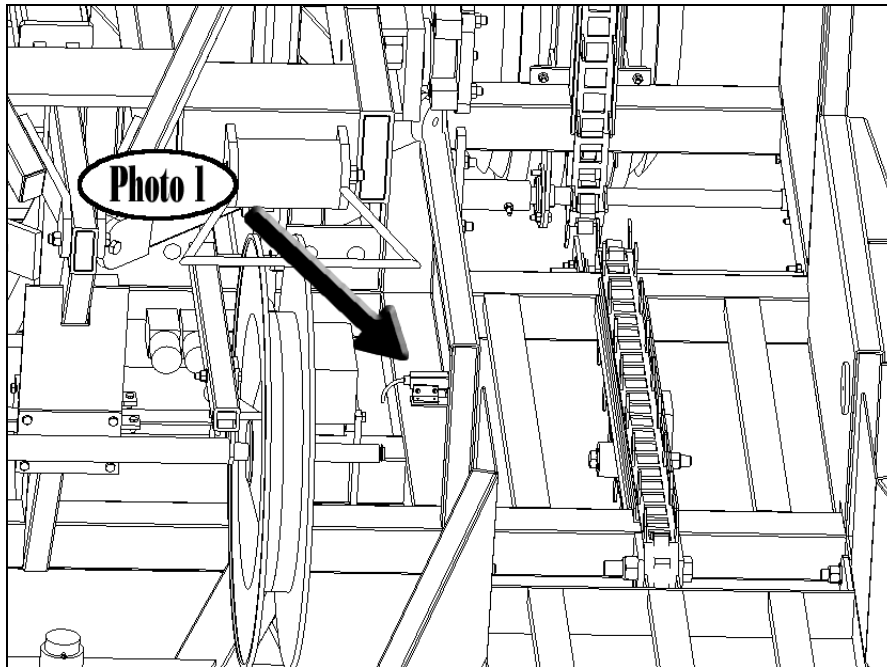

200 Photo 2 Ready, Waiting for the Bale

- The machine is waiting for the elevator to move the bale at Photo 1 to Photo 2.
- If Photo 1 was tripped prematurely this will be displayed until a bale enters the machine and trips Photo 2. The horizontal & vertical elevator will both be running but nothing needs to be done to fix this. As soon as the next bale enters the machine it will clear out the false reading at Photo 1. This will not affect the bale count in any way. Be sure to wipe clean Photo 1 so that this premature reading ends. Check the indicator light on top of Photo 1 to see that it is sensing properly.

-Elevator will have the following state:

- Horizontal and Vertical elevator will be on.

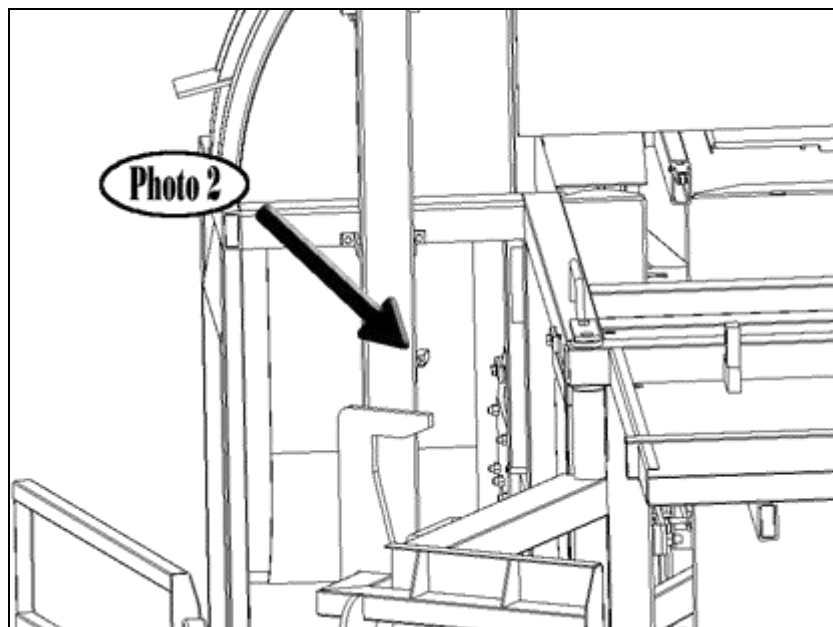

300 Photo 3 Error, Unplug power and clean Photo 3

- The machine has stored the bale at Photo 2 and is waiting for Photo 3 sensor to be 'off'. Photo 3 is 'off' when a bale or foreign object is blocking the view of the photo sensor. Occasionally, chaff or dust can cause this error to occur. Disconnect the main electrical and hydraulic power. Once the main electric cord has been disconnected, open the banding box lid and remove any chaff or dust from the view of Photo 3. Once this has been done, reconnect electrical and hydraulic power. The elevator will then turn on, moving the bale from Photo 2 to Photo 3 and the machine will continue operation. Note: If you do not disconnect the main electrical power prior to clearing the view of the photo eye, you will 'false' trip Photo 3 and the machine will miss count by one bale.

-Elevator will have the following state:

- Horizontal and Vertical elevator will be off.

Things that could cause a 'false' trip:

- A lens that was at one time wet with dew or hydraulic oil and collected dust.
- A piece of chaff being continuously in front of the lens.

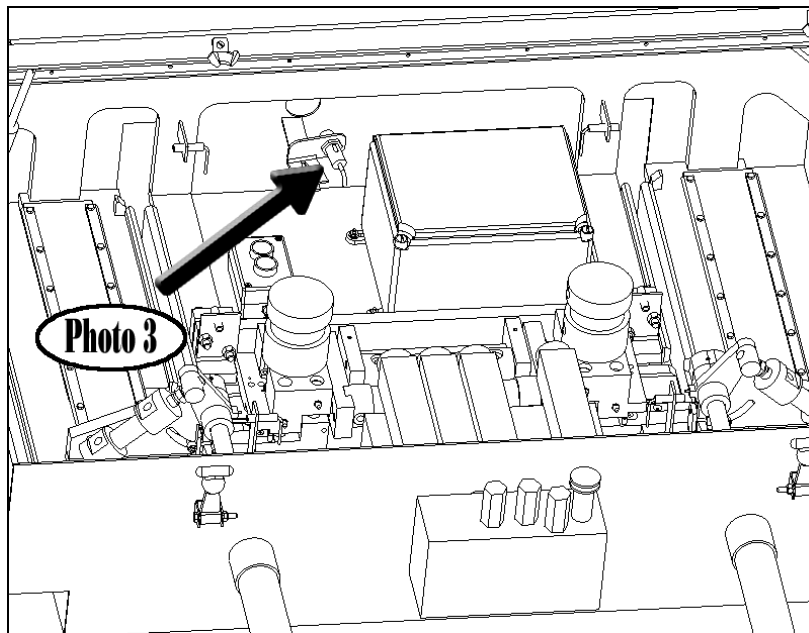

400 Photo 3 Ready, Waiting for the Bale

- The machine is waiting for the elevator to move the bale at Photo 2 to Photo 3.
- If this message is shown and there is no bale at Photo 2 to move to Photo 3, then the lens on Photo 2 needs to be cleaned. If the lens of Photo 2 is partially covered by dirt or chaff or if Photo 2 was prematurely tripped by a foreign object, the bale at Photo 1 would not have had enough time to move to Photo 2 before the horizontal elevator chain shut off. Nothing needs to be done other than continue baling. The baler will continue to push the bales back and eventually the vertical elevator (which in this case, is continuously running) will take the next bale and clear out the false trip.

-Elevator will have the following state:

- Horizontal elevator will be off.
- Vertical elevator will on.

Things that could cause a 'false' trip:

- A lens that was at one time wet with dew or hydraulic oil and collected dust.

- A piece of chaff being continuously in front of the lens.
 - The photo sensor's distance adjustment being set too far and reflecting off the pressure plate (Photo 2).
- If bale is stuck while going around the curve at the top of the hay elevator,
 - If bale is against the 1 inch (25 mm) bent rod attached to the vertical plunger,
 - Adjust the stop on the pressure plate to give less distance from pressure plate to elevator chain.
 - If bale is stalling out the elevator motor,
 - Adjust the stop on the pressure plate to give more distance from pressure plate to elevator chain.
 - If elevator chain is tearing through the bale,
 - Tighten the spring tension on the pressure plate.

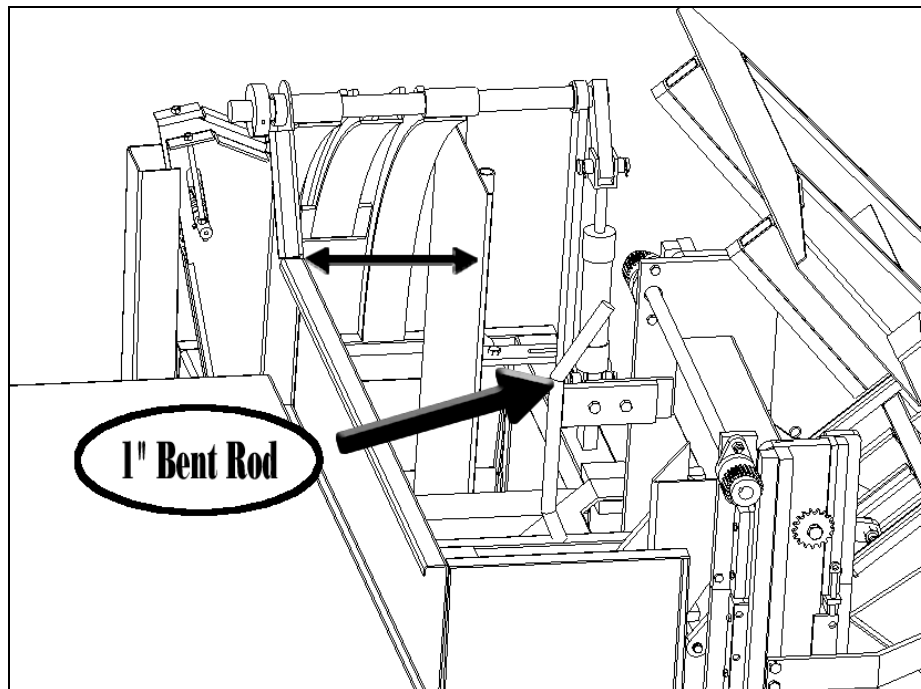

- 900 Resetting.....
 - Bale Band-It is resetting, please wait.
- 901 Rebooting.....
 - Bale Band-It is rebooting, please wait.
- 902 Back Floor Unloading
 - Not an error code, just informative that the Back Floor is unloading the bundle. This occurs on Bale 12 of each bundle.
- 903 Banding Cycle, Leave Hydraulics On!
 - Bale Band-It is compressing and tying the bundle. If hydraulics is removed during this time the bundle may or may not be strapped properly. If at all possible leave hydraulic power on to the machine unless an emergency or machine failure.
- 904 Communication Delay

- Disengage hydraulic power and unplug main power cord. Wait for approximately 10 seconds, plug back in and engage hydraulic power.
- On Line 3 of Display Monitor, if the number after the dash is 0, then disconnect main electrical and hydraulic power. Open the plastic computer box in the banding box and unplug the two 10 amp fuses. Reconnect main electrical power only. Wait approximately 10 seconds and then reinstall the two 10 amp fuses at the same time. Recheck number on Line 3 after the dash, it should then be 1. Apply hydraulics.

Troubleshooting

If strapping is cutting twine on bales:

- Use minimum of 170 pounds (756.2 N) knot strength twine.
- Strapping not threaded correctly.
- Back gate hydraulic valve adjustment is set too high.
- Check all areas for excess drag on strapping.

Bundles are not tight.

- Turn clockwise the back gate pressure relief valve

BALE BAND-IT stops operating and the Tractor Monitor displays ‘Out of Strapping’ and buzzer is on.

- Check amount of strap on banding drums and push ‘Reset Banding’ button

BALE BAND-IT stops operating and light/buzzer on machine is on.

- Check hydraulic power
- Check ‘Display 2’ for operation status (page 0-4 and 0-5)

BALE BAND-IT stops operating and light/buzzer on machine is off.

- Check electrical plugs for disconnect or other power supply problems
- Check Emergency Stop button, it needs to be pulled out

Elevator motor runs continuously.

- Check ‘Photo Eye’ 1 & 2 sensors for correct alignment

BALE BAND-IT begins to operate slowly.

- Check hydraulic supply level and temperature
- Check that hydraulic pressure line hose is connected to primary remote on tractor
- Check that hydraulic return line hose does not return into the tractor’s remote but directly into the tractor’s tank
- Check visual indicator on **BALE BAND-IT** hydraulic filter. When filter needs changed the indicator will be sticking up approximately 1 inch (25.4 mm).

BALE BAND-IT loses count of bales when electrical power is disconnected or after tractor is shut off.

- Battery on computer board needs to be replaced. Contact Pike Mfg. Corp. before opening inner computer box. Use only lithium AA batteries. (Change approximately once every 5-10 years)

Bundles not banded when they come out of machine.

- Check for strapping on banding drum
- Check that strap is properly threaded
- Check that grippers in banding box are holding strap during the first three bales of every bundle

Grippers in band box are not holding strap.

- Tighten the 5/16” bolt and nut that is connected on the red handle clamp
- Tighten nut that fastens red handle clamp to bracket

Display indicates that a read switch is not making contact.

- Magnetic Read Switches on the Horizontal Plunger need to have an air gap of 3/8" (9 mm).
Read switches on the Kicker, and all Banding box switches need an air gap of 1/8" (3 mm).

Display indicates that a photo eye is not on.

- When a photo eye is directed toward an object (bale) the indicator light on the sensor will be on.

BALE BAND-IT

End of

Operator's Manual

Model 100

For more information, contact Pike Mfg. Corp. at

Pike Mfg. Corp.
P.O. Box 492
Alpena, MI 49707
(217) 285-6487
www.balebandit.com
sales@balebandit.com