

EVERDURE KILN

INSTRUCTION MANUAL



Scan for
further support

CONTENTS

Important Safety Instructions.....	3
Appliance Details.....	4
Outdoor Installation Guide.....	5
Battery Installation.....	6
Operating Instructions.....	7
Cooking Hints and Tips KILN S Series - 1 Burner.....	8
Cooking Hints and Tips KILN R Series - 2 Burner.....	9
Care & Maintenance.....	10
Troubleshooting.....	12
Specifications.....	13
Warranty.....	14

Note; In this instruction manual, the Everdure Kiln will be referred to as an appliance.



**1 BURNER
GRAPHITE**

EKILN1G



**1 BURNER
STONE**

EKILN1S



**1 BURNER
TERRACOTTA**

EKILN1T



**2 BURNER
GRAPHITE**

EKILN2G



**2 BURNER
STONE**

EKILN2S



**2 BURNER
TERRACOTTA**

EKILN2T

* All products, specifications and data are subject to change without notice to improve reliability, function, design, or otherwise.

IMPORTANT SAFETY INSTRUCTIONS:

- DO NOT** operate this appliance before reading the instruction booklet.
- DO NOT** place articles on or against this appliance.
- DO NOT** store chemical or flammable materials or spray aerosols near this appliance.
- DO NOT** operate this appliance indoors.
- DO NOT** use an adapter at the cylinder connection.

Remove all packaging materials and dispose of thoughtfully before first use.

IMPORTANT SAFETY INSTRUCTIONS

IMPORTANT: Read the safety precautions of this booklet carefully before removing the appliance from its carton or connecting the appliance to its gas supply. If you are unsure about anything regarding your appliance, please contact Everdure in Australia on 1300 437 866 or in New Zealand on (09) 415 6000 before operating your appliance.

1. This gas appliance is intended for **OUTDOOR USE ONLY**. This appliance must **NOT** be used indoors.
2. For your safety and enjoyment, read all operating instructions before lighting.
3. Ensure that all gas connections are tight before operating this appliance (refer to leak testing procedure in this manual). Always check for leaks when a gas cylinder is replaced or reconnected.
4. Unsupervised children or pets should not be near a appliance while cooking or during warm up or cool down. Ensure children or pets are kept a distance well away from the appliance whilst it is in use. Ensure that young children do not play with the appliance. This appliance is not intended for use by young children or infirm persons.
5. Turn gas valve/control knob and gas cylinder valve off after use. Do not allow build-up of unburned gas.
6. Never leave the burners on high for more than 30 minutes unless actually cooking.
7. Do not move this appliance while in use or directly after use, as accessible parts may be very hot. The appliance. Take care that undue pressure will not be placed on the gas hose, or turn off the gas supply & remove the hose from the cylinder or gas source (not at the appliance).
8. People with flammable clothing such as nylon etc. should keep well away from the appliance when it is operating.
9. Do not use this appliance for any purpose other than what it is intended for.
10. Ensure that the product has adequate clearance from combustible materials. The appliance is designed so that heat will not affect the stand. All combustible materials must be kept more than 250mm from the sides and rear of the appliance and more than 1500mm above the cooking surface of the appliance.
11. If a burner makes a hissing sound when lit, it may be burning inside. Turn the burner off, allow to cool, and try ignition again. Keep your appliance protected against strong wind – if this cannot be avoided, always check that the burners remain alight if operating the appliance in windy conditions.
12. Do not carry out any servicing on the gas manifold of the appliance yourself – this must only be done by authorised technicians.
13. We recommend that you regularly maintain your appliance and keep it in good condition. This can be achieved by following the cleaning and maintenance suggestions in this booklet.
14. The appliance is designed to be used with either 4kg or 9kg gas cylinders. Keep the cylinder as far away as the hose will allow without undue tension on the hose, in a protected spot (so it cannot be accidentally knocked over).
15. Do not use or store this appliance in areas of high salt content (a marine environment) or an area with caustic fumes or liquids (such as a domestic pool), as these chemicals can cause the appliance materials to deteriorate (and void the warranty). Regular cleaning and covering with a cover can help to reduce this.

WHEN USING AND COOKING IN YOUR EVERDURE KILN OVEN

Do **NOT** leave the main burner on **HIGH** setting for over 30 minutes after ignition. Please refer to **COOKING HINTS** and **TIPS KILN S/R SERIES** page in the instruction manual on preheating, cooking and after cooking instructions.

FOR ULPG CYLINDER CONNECTION:

- For storage and cylinder exchange, disconnect the cylinder only. Do not disconnect hose from the appliance.
- To achieve the optimum performance from your appliance, an approved gas cylinder (Type 27 fitting) of 4kg or 9kg capacity must be used. Take care to keep the hose away from the hot appliance.
- The Length of the hose must not exceed 1.5m.
- Connect the cylinder to the appliance, via the hose and regulator. Firmly tighten joints, but do not overtighten and do not twist. Take care not to damage the regulator fitting. Check that ALL appliance valves are in the Off position before opening the gas cylinder.
- Regulator hose must be kept away for sharp object and heat sources.
- When changing cylinders, ensure the gas it turned off before disconnecting the hose & regulator assembly from the cylinder only (not from the appliance manifold).

LEAK TESTING

- Make sure the gas control knob is Off and turn the cylinder valve On.
- Check for leaking joints by brushing with solution of half-liquid detergent and half water. If a leak is present, bubbles will appear (or you may hear a hissing sound). Retightening connections can generally repair a leaking joint. You must also check the gas hose and connection at the gas cylinder. If a leak cannot be resolved, do not proceed.

NOTE: Make sure the gas cylinder is fully protected from the elements. Only one gas cylinder should be stored inside the cabinet at any one time. Do not fully enclose the cylinder.

APPLIANCE DETAILS:

Note: the size of the injector diameter is stamped on the hexagon faces (105 = Ø1.05mm injector).

Appliance inlet connection: 3/8"SAE Flare with 5/8-18 UNF thread.

APPLIANCE		EKILN1	EKILN2
GAS TYPE		ULPG	ULPG
BURNER PRESSURE	PRIMARY	2.75kPA	2.75kPA
	SECONDARY	-	2.75kPA
INJECTOR DIAMETER	PRIMARY	1.47mm	1.47mm
	SECONDRAY	-	0.4mm
HEAT INPUT		26mj	28mj

PRODUCT DETAILS	EKILN1	EKILN2
Dimensions (mm)	740 × 660 × 380	740 × 660 × 380
Weight NW/GW (kg)	26.5 / 33.3	29.2 / 35.0

OUTDOOR INSTALLATION GUIDE:

This appliance shall only be used in an above ground open-air situation with natural ventilation, without stagnant areas, where gas leakage and products of combustion are rapidly dispersed by wind and natural convection.

This appliance must not be used indoors. Do not use your appliance in garages, porches, sheds, or other enclosed areas. The appliance is not intended to be installed in or used on recreational vehicles (e.g., boats, camping vans) and should not be placed close to or under any surfaces that will burn or are sensitive to heat. Do not block/obstruct the flow of air and combustion around the appliance housing while in use.

Any enclosure in which the appliance is used shall comply with one of the following:

- An enclosure with walls on all sides, but at least one permanent opening at ground level and no overhead cover.
- Within a partial enclosure that includes an overhead cover and no more than two walls
- Within a partial enclosure that includes an overhead cover and more than two walls, the following shall apply:
 - a. at least 25% of the total wall area is completely open: and
 - b. at least 30% of the remaining wall area is open and unrestricted.

In the case of balconies, at least 20% of the total of the side, back and front wall areas shall be and remain open and unrestricted.

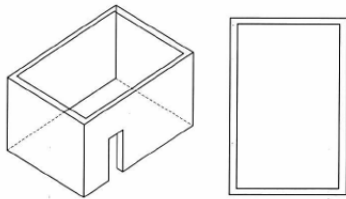

Figure F1 - Outdoor Area - Example 1

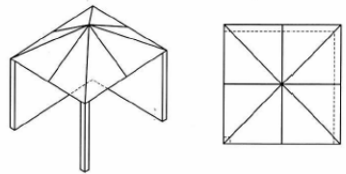

Figure F2 - Outdoor Area - Example 2

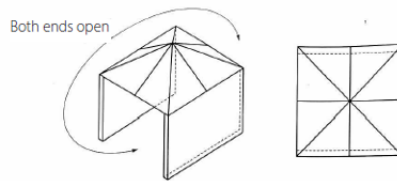

Figure F3 - Outdoor Area - Example 3

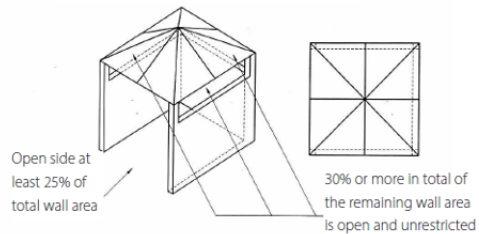
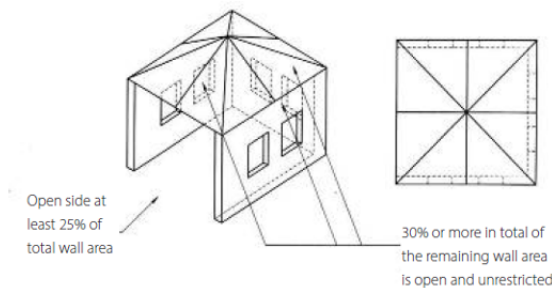
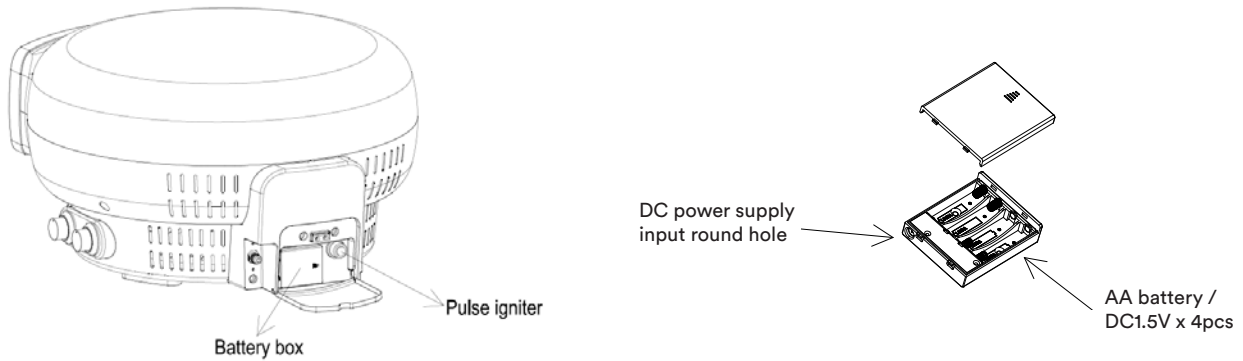

Figure F4 - Outdoor Area - Example 4



BATTERY INSTALLATION

1. Unscrew pulse igniter cap fit one new AA battery note the (+) and (-) marking refit the cap.
2. EKILN R Series, Remove the battery compartment cover. Load a set of four new "AA" type batteries so that their plus (+) and minus (-) ends are facing as indicated by the markings. Refit battery compartment cover.



SAFETY WARNING



Please read these instructions before using your appliance.

This appliance has been fitted with the latest design safety device: a Flow Limiting Gas Regulator. This regulator helps protect the user by reducing the gas flow into the appliance in the case of a gas leak.

For optimum ease of use, please follow the following instructions:

1. Before turning the gas cylinder on, ensure that the appliance and side burner control knobs are all at the OFF position.
2. Slowly turn the gas cylinder on until the valve is fully open, and then ignite the appliance as directed in the appliance instruction booklet.

Failure to observe these instructions may result in the flow limiting device to lock up at a reduced gas flow rate. This is generally observed as a reduced flame from the burners or an increase in the cooking time.

If the appliance is found to be operating at a reduced rate, check the following items:

1. Check that there are no gas leaks (follow the instructions in the appliance instruction booklet).
2. Check that the gas cylinder is turned on.
3. Check that the gas cylinder is not empty.

If all three points are ok, follow the following instructions to reset the flow limiting device:

1. Turn all of the appliance controls to OFF.
2. Turn the gas cylinder fully off.
3. Wait 30 seconds for the flow limiting device inside the regulator to reset.
4. Slowly turn the gas cylinder back on until fully open, and then ignite the appliance as directed in your appliance instruction booklet.

If after following these instructions, you are still having problems with the appliance running at a reduced capacity, please contact Everdure in Australia on 1300 437 866 or in New Zealand on (09) 415 6000 before operating your appliance.

OPERATING INSTRUCTIONS:

Once your regulator is connected, open the gas from your gas cylinder.

KILN 1 Burner



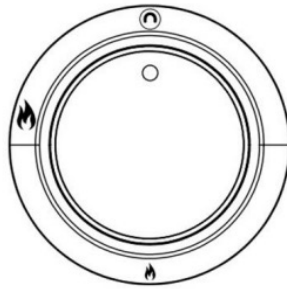



To ignite the burner, please push the knob in and slowly turn anti clockwise until you hear a click of the ignition. This should take at least 8-10 seconds as you allow the gas to flow into the burner inside the oven. Hold in for another 10 seconds after ignition, then release. Set the burner to your desired requirement. If the burner does not light, leave the knob at OFF and wait 5 minutes before retrying.

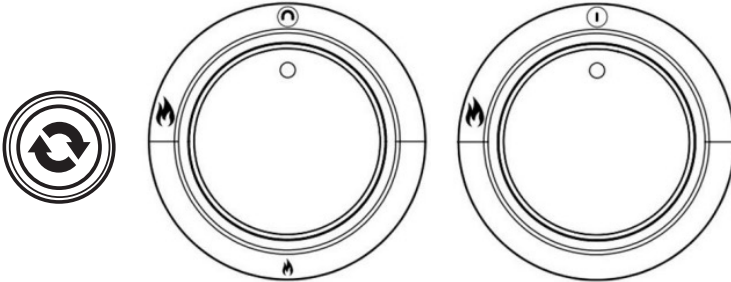

KILN 2 Burner

To ignite the burners, please push the knob in and slowly turn anti clockwise until you hear a click of the ignition. This should take at least 8-10 seconds as you allow the gas to flow into the burner inside the oven. Hold in for another 10 seconds after ignition, then release. Set the burner to your desire requirement. Press the button between the 2 knobs for the turntable to begin rotating inside the oven. If the burner does not light, leave the knob at OFF and wait 5 minutes before retrying.



Symbol	Function	Symbol	Description
	Off		Main burner
	Low		Boost burner
	High		Turntable rotation

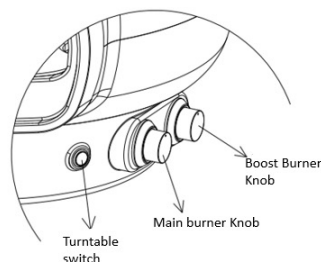
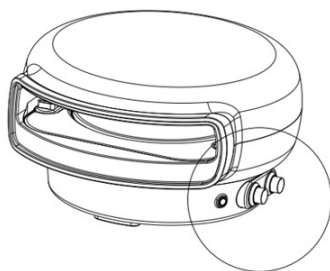

COOKING HINTS AND TIPS KILN S SERIES - 1 BURNER

Preheating

Ignite the appliance and leave it on high for approx. 15 to 20min. This will give you enough time to heat the stone to your desired cooking temperature.

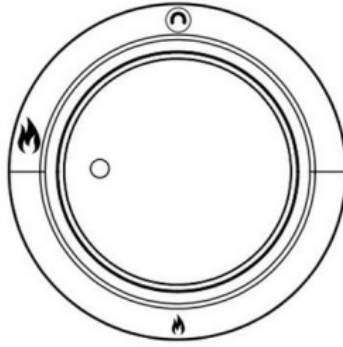

Cooking

When the appliance has reached your desired cooking temperature, turn the knob to halfway.

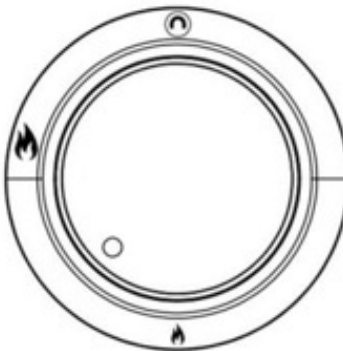

After cooking

Once you have cooked on the appliance, just before you go to eat and if you are continuing to cook, turn the main burner down to the low setting. If you have finished cooking on the appliance, turn the main burner off. Running the appliance for an extended period of time with the main burner on the high setting could result in damage to your appliance.

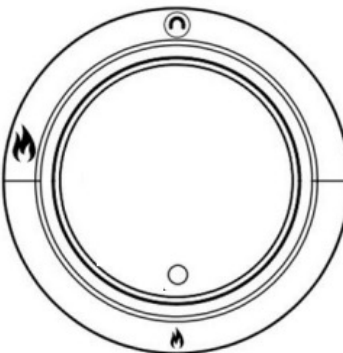

COOKING HINTS AND TIPS KILN R SERIES - 2 BURNER

Preheating

Start the turntable by pressing the button. Ignite both burners and leave on high for approx. 10min. This will give you enough time to heat the stone to your desired cooking temperature. Note: the boost burner only has one setting. Don't leave the boost burner on without the turntable rotating.

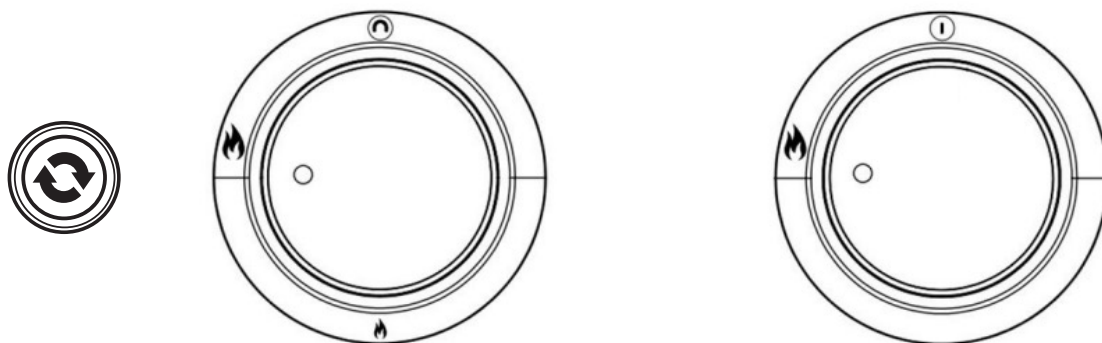

Cooking

When the appliance has reached your desired cooking temperature, turn the main burner knob to halfway.

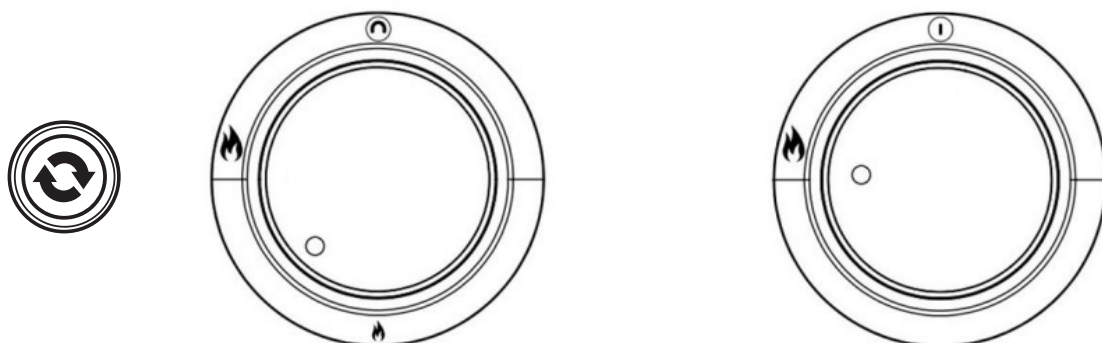

After cooking

Once you have cooked on the appliance, just before you go to eat and if you are continuing to cook more, turn the main burner down to the low setting. If you have finished cooking on the appliance, turn both the main and boost burner off. Running the appliance for an extended period of time with the main burner on high setting could result in damage to your appliance.

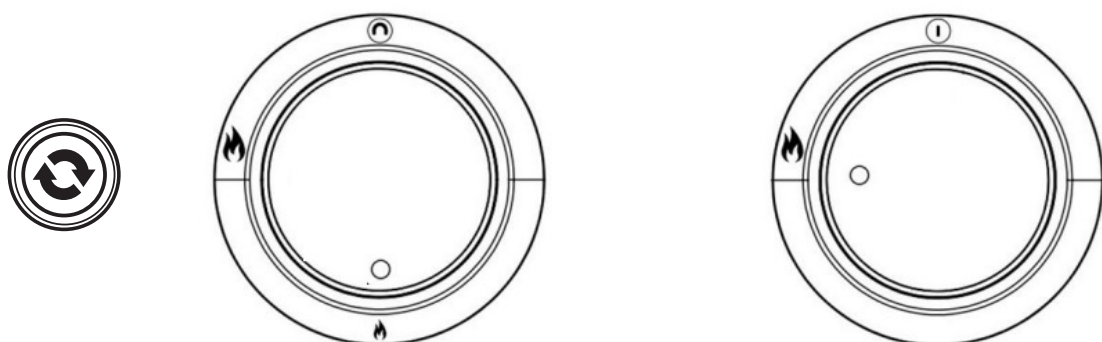

BOOST BURNER INSPECTION HOLE



Visual inspection hole to check whether the boost burner flame is on or off.

CARE & MAINTENANCE:

EXTERNAL CLEANING

- Before cleaning the appliance exterior, ensure the appliance has cooled and is safe to touch.
- Painted and plastic surfaces can be cleaned using a mild household detergent or cleaner and a clean cloth (do not use scourers or harsh detergents).
- It is advisable to test cleaners on a small section of the appliance first. **NEVER** use paint thinners or similar solvents for cleaning and **NEVER** pour cold water over hot surfaces.
- Dry the surface afterwards.

INTERNAL CLEANING

- Before cleaning the internal parts of your appliance, ensure the appliance has cooled and is safe to touch.
- The inside of the appliance can be cleaned by using some water, mild detergent and a sponge or mild scouring pad.
- For hard to clean areas, use a little baking soda on a wet sponge. **DO NOT** use abrasive cleaners.

CORDIERITE PIZZA STONE CARE

- This pizza stone is designed to be used in the Everdure Kiln only.
- Only use water to clean the pizza stone, using soap will leave residue in the pores of the stone.
- Take care of the pizza stone as it is fragile and could break if bumped or dropped.
- Be careful handling the pizza stone as it can retain heat for many hours after cooking.
- **DO NOT** cool the stone with water when the stone is hot; this could crack and damage the pizza stone.
- After cleaning the pizza stone with water, **thoroughly dry the stone before use.**

MAINTENANCE

- Regularly check all gas hose and line connections for damage, cuts or cracks each time before use of the appliance.
- Leak test with soapy water before first use and at least annually. Always check when replacing the gas cylinder.
- Check the burners regularly for insect mess from spiders, ants etc, if any signs clean before operation.

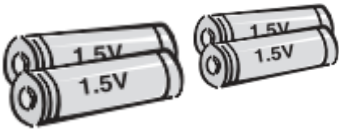
BATTERIES DO'S & DO NOT'S

- Dispose of used batteries carefully to ensure that a small child does not consume them.
Please seek doctor - medical attention immediately if batteries are consumed.
- **DO NOT** mix new batteries with old batteries. This may cause the batteries to overheat and leak.
- **DO NOT** place non-rechargeable batteries in a charging device.
- **DO NOT** disassemble, crush, puncture, or otherwise damage batteries. This can result in leakage or rupture.
- **DO** preserve battery life by switching off a device and removing the batteries when it's not being used and is not expected to be used for extended periods of time.
- **DO** use the specified type of battery (AA Batteries).
- **DO** insert the batteries properly. Follow the symbols showing the correct way to position the positive (+) and negative (-) ends of the batteries.
- **DO** immediately remove exhausted batteries from your device and dispose of them properly.

TROUBLESHOOTING:**Burner will not ignite when using the igniter:**

Cylinder valve is not on	Turn cylinder valve on
Cylinder is empty	Replace with a full cylinder
Igniter button is not working	Check battery
Igniter is not sparking	Contact the Service Centre

Burner flame is erratic:

Flame is burning inside burner (hissing sound)	Turn off burner, allow to cool and re-ignite
Regulator is faulty	Contact the Service Centre
Injector is partially blocked	Clean injector with a toothbrush. Do not drill out or use wire. Do not remove the injector. Contact the Service Centre

Gas is leaking from connections:

Connections are loose	Tighten loose connections (do not over-tighten) and leak test under pressure with a soapy water solution (page 2)
Hose has deteriorated	Replace hose (Contact the Service Centre)
Gas valve is faulty	Contact the Service Centre
Threads are damaged	Contact the Service Centre

Turntable not working:

Turntable not turning	Check that the power cord from the power adaptor is connected correctly and that the power is on at the main power board. Check if batteries are fitted and are properly installed in the battery compartment. Check if batteries are full of charge and replace if needed.
Turntable is broken	Contact the Service Centre
Switch or wiring damaged	Contact the Service Centre

SPECIFICATIONS:

PRODUCT	1 BURNER	2 BURNER
Dimensions (mm)	740 × 660 × 380 (mm)	740 × 660 × 380 (mm)
Weight NW / GW	28.5 / 33.3 (kg)	29.2 / 35.0 (kg)
Turntable RPM using the adapter supplied	N/A	2.5 rpm

Power supply EKILN2 only:

MODEL	SPECIFICATION	REMARK
	Model: AED09-030GQAAIP44 Input: AC 100~240V ~50/60Hz 0.6A Output: 3.0V 1000mA IP44	With plug round hole which match-up with DC005 / 5.5*2.1 pin

WARRANTY

PRIVACY POLICY

Privacy policy: Everdure is committed to protecting your personal privacy. Your personal information that you have provided in this form (e.g., name, street address, e-mail address and telephone/mobile number) is used solely by Everdure for the express purpose for which it was collected (e.g., to respond to your enquiry regarding your product). Your personal information will be processed by Everdure in accordance with the guidelines and requirements of the Privacy Laws of Australia (Privacy Act 1998).

For a full copy of Everdure's Privacy Policy, please e-mail customercare@shiro.com.au in Australia or customercare@monacocorp.co.nz in New Zealand or call **1300 766 066** in Australia or **(09) 415 6000** in New Zealand.

STATEMENT OF STANDARD WARRANTY CONDITIONS

AUSTRALIAN CUSTOMERS

Our goods come with guarantees that cannot be excluded under the Australian Consumer Law.

You are entitled to a replacement or refund for a major failure and compensation for any other reasonably foreseeable loss or damage.

You are also entitled to have the goods repaired or replaced if the goods fail to be of acceptable quality and the failure does not amount to a major failure.

NEW ZEALAND CUSTOMERS

Nothing herein contained shall be construed in any way as excluding or limiting your rights under the Consumer Guarantee Act 1993.

OUR WARRANTY

Subject to the following conditions, this product is also covered by the manufacturer's warranty from the date of purchase, covering all parts and labour for the period listed below (Our Warranty). Our Warranty (which is subject to the conditions below) covers rectification free of charge of any fault arising from defected materials or components, or faulty workmanship. The product will be repaired or replaced at the option of Everdure, but all costs of installation, removal, cartage, freight, travel expenses and insurance are to be paid by the claimant. Our Warranty is subject to products being used for single-family domestic household use.

OUR WARRANTY

operates in addition to (and does not exclude, restrict, or modify) any rights or remedies to which you may already be entitled to under the Australian Consumer Law or any consumer guarantee law relating to this product.

WHAT IS COVERED: By Our Warranty

During the warranty period your appliance will be repaired free of charge by Everdure, or its authorised service centre provided your appliance is delivered to and picked up from Everdure or its authorised service centre, subject to terms and conditions below.

It is recommended that exposure of the appliance to the elements should be minimised. After your appliance has cooled and has been cleaned, store it under cover with a weatherproof cover over it.

APPLIANCE COMPONENT	WARRANTY PERIOD
Stainless Steel Parts	2 years
Enameled Parts Powder Coated Panels Cooking Stone & All Other Assemblies / Parts	2 years

WHAT IS NOT COVERED: BY OUR WARRANTY

1. Any defect or failure caused by the product not being assembled or used in accordance with the instruction/ installation manual provided with the product.
2. Normal fair wear and tear (e.g., surface rust, stone chipping, heat discolouration)
3. Insect or vermin infestation.
4. Unauthorised repairs or use of non-genuine Everdure parts.
5. Products scratches & damage as a result of delivery, installation, or assembly
6. Claims to product surface coatings due to accidental damage, improper or lack of maintenance, damage from cleaning products not recommended by Everdure.

HOW TO CLAIM WARRANTY

You will need to contact Everdure in Australia or New Zealand using the enclosed contact details. Please make sure you have the following information on hand:

- Product Name/Model Number
- Serial Number
- Purchase Date (as per invoice, or proof of purchase)
- Place of Purchase

IN AUSTRALIA

Everdure is a division of Shriro Australia Pty Limited
 ABN 28 002 386 129
 Customer care: 1300 766 066
 Email: customercare@shriro.com.au

IN NEW ZEALAND

Everdure is a division of Monaco Corporation Ltd
 (Member of Shriro Australia PTY LTD)
 Phone: (09) 415 6000
 Email: customercare@monacocorp.co.nz

EVERDURE KILN

www.everdure.au

IM REF: EKILN AU 26/07/2023