

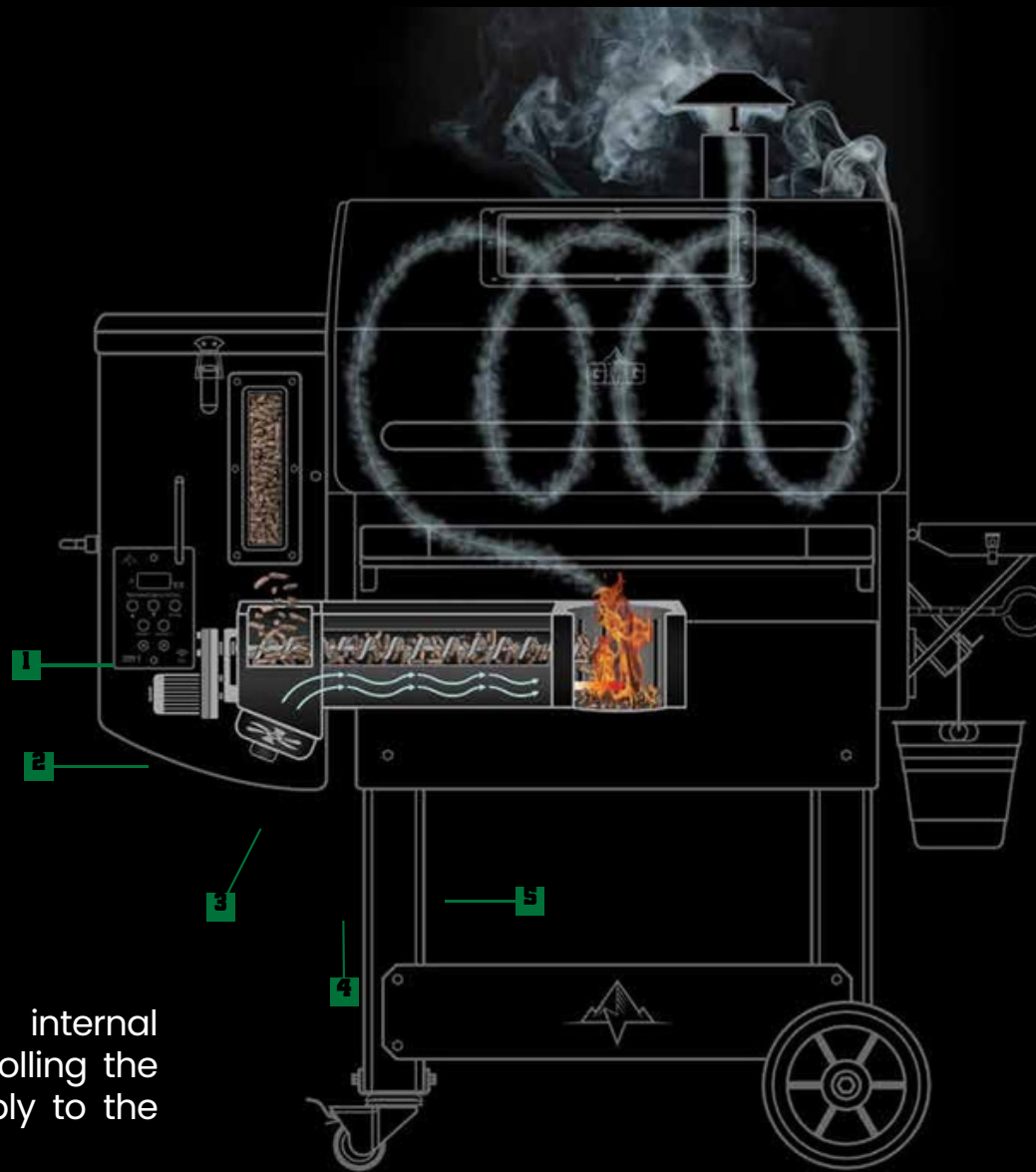

PRIME 2.0



1 DIGITAL CONTROLLER

Manages the internal temperature by controlling the fuel and oxygen supply to the firebox.

2 AUGER MOTOR

Turns the auger which feeds pellets into the firebox.

3 COMBUSTION FAN

The micro-adjusted variable-speed fan and auger motor allow you to keep your grill and food at the temperature you set.

4 HEAT ROD

Ignites the pellets and the combustion fan keeps them burning.

5 FIREBOX

The Venturi-style firebox creates the ultimate wood-burning fire, circulating pure hardwood smoke and flavor throughout the grill.

WOOD-FIRED SCIENCE

— HOW IT WORKS —

INTRODUCING **PRIME 2.0**





PEAK PRIME™ 2.0

WIFI SMART CONTROLLED

Introducing PEAK PRIME™ 2.0, the ultimate wood-fired BBQ solution. With 12-V Direct Power for consistent heat and flavour, this innovative grill offers optimal heat distribution and 360° wood-fired greatness. Customize with GMG RACKT™ technology and elevate your cooking with GMG SideBURN™ attachment. Upgrade your BBQ inventory today!

HOPPER LID MUST BE CLOSED
WHEN THE GRILL IS ON

388 °F/C
TEMPERATURE CONTROL
POWER
PROBE 1 PROBE 2
WIFI
USB

PEAK PRIME 2.0 FEATURES

AC + DC Dual Power Versatility
WiFi Smart Control
Rounded/Peaked Hybrid Lid
Grilling Light
Accessory Side Shelf
150°-550°F Temp Range
Dual Meat Probes
USB Charging Port
Bottle Opener

MUST HAVE ACCESSORIES

RACKT™

SideBURN™ Infrared Searing Station

Wood-Fired Pizza Oven

BBQ Rotisserie

SPECS

| | |
|-----------------|-------------|
| HEIGHT | 130cm |
| WIDTH | 159cm |
| DEPTH | 92cm |
| WEIGHT | 98kgs |
| COOKING CHAMBER | 51cm X 95cm |
| HOPPER CAPACITY | 9.07kgs |





LEDGE PRIME™ 2.0

WIFI SMART CONTROLLED

Upgrade your backyard BBQ with LEDGE PRIME™ 2.0! Enjoy premium wood-fired flavour with 12-V Direct Power for consistent heat. Its rounded/peaked hybrid chamber design ensures optimal heat distribution and 360° wood-fired excellence. Customize with GMC RACKT™ technology for elevated racks, shelves, pans, and more. Boost your cooking with the GMC SideBURN™ attachment, transforming your side shelf into a high-heat side burner.

LEDGE PRIME 2.0 FEATURES

AC + DC Dual Power Versatility
WiFi Smart Control
Rounded/Peaked Hybrid Lid
Grilling Light
Accessory Side Shelf
150°-550°F Temp Range
Dual Meat Probes
USB Charging Port
Bottle Opener

MUST HAVE ACCESSORIES

RACKT™
SideBURN™ Infrared Searing Station
Wood-Fired Pizza Oven
BBQ Rotisserie

SPECS

| | |
|-----------------|-------------|
| HEIGHT | 130cm |
| WIDTH | 132cm |
| DEPTH | 85cm |
| WEIGHT | 84kgs |
| COOKING CHAMBER | 51cm X 69cm |
| HOPPER CAPACITY | 9.07kgs |





TREK PRIME™ 2.0

WIFI SMART CONTROLLED

Start your wood-fired journey with TREK PRIME™ 2.0! This compact grill delivers exceptional wood-fired flavor using 12-V Direct Power for consistent heat. Perfect for backyard BBQs, camping, or tailgating, TREK ensures superior heat distribution with its rounded/peaked hybrid chamber design. Revolutionize your outdoor cooking with TREK PRIME™ 2.0 and elevate your experience with the optional TREK CART, sold separately.

TREK PRIME 2.0 FEATURES

AC + DC Dual Power Versatility
WiFi Smart Control
Rounded/Peaked Hybrid Chamber
Wood-Fired Pizza Oven Enabled
150°-550°F Temp Range
Meat Probe
TREK Cart Enabled



SPECS

| | |
|-----------------|---------------|
| HEIGHT | 61cm |
| WIDTH | 87cm |
| DEPTH | 46cm |
| WEIGHT | 30kgs |
| COOKING CHAMBER | 45cm X 33.5cm |
| HOPPER CAPACITY | 4kgs |

TREK CART

Easy slide in & fastening
Collapsible front & side shelves
Bottom storage shelf
Reinforced chassis
Wide durable legs
Locking caster wheels





RACK™ SYSTEM

The new customizable Rack Technology system that allows for easily attachable elevated racks, smoke shelves, cooking pans, and griddles. Wood-fired versatility and customization made easy!



#GMG6049 (Ledge)
#GMG6050 (Peak)

RACKT Module - Backboard



#GMG6051

**RACKT Module - Chicken Leg
Suspender**



#GMG6054

RACKT Module - Warming Rack



#GMG6053

RACKT Module - Rib Rack



#GMG6052

RACKT Module - Griddle

A hand is shown hovering just above a glowing orange SideBURN attachment. The attachment consists of several parallel metal bars that are illuminated from within, creating a bright orange glow. The background is dark, and the overall scene is set against a black surface, likely a grill. The word "LEDGE" is visible in the background on the left side. In the bottom right corner, there is a red digital display showing "SIDE BURN" and "211".

SIDE BURN™

The new SideBURN™ attachment transforms your side shelf into a high-heat infrared side burner and secondary cooking surface, the ultimate searing station. Suitable with PEAK PRIME™ 2.0 & LEDGE PRIME™ 2.0 as well as older models.

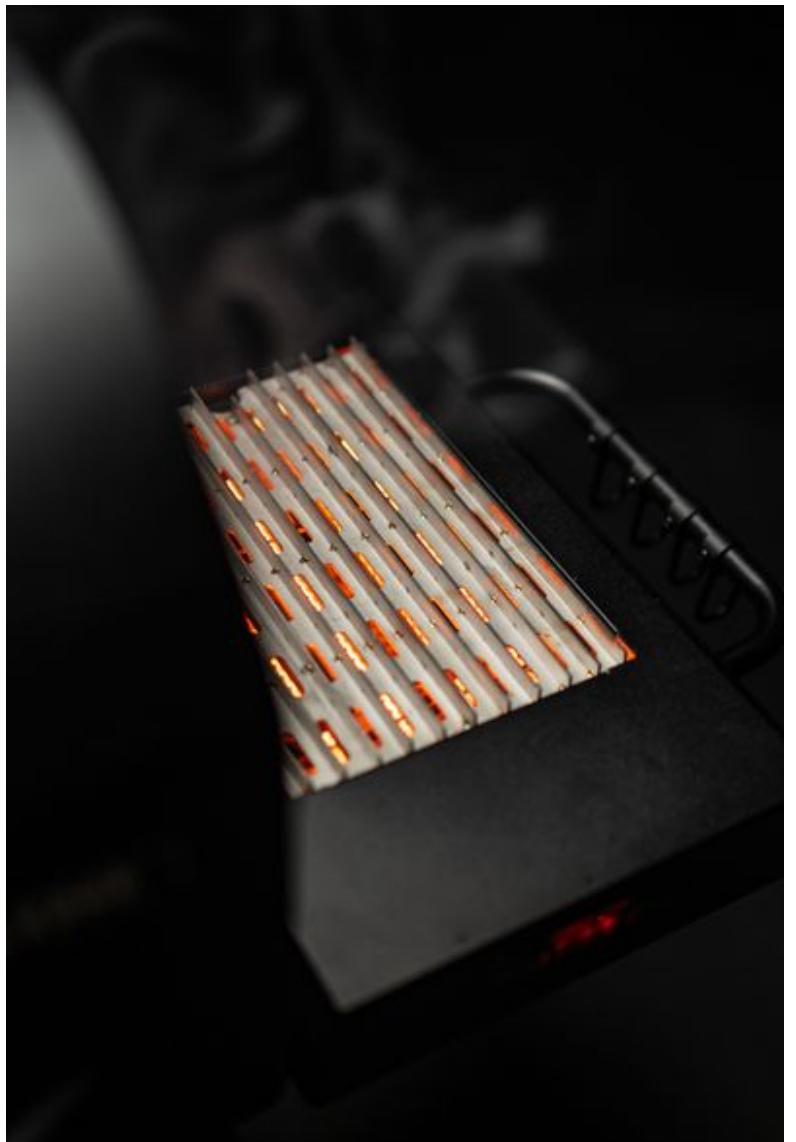

#GMG6042





WOOD-FIRED ROTISSERIE

Convert your GMG into a Wood-Fired Rotisserie. Built to withstand the outdoor elements, the 240V motor is enclosed in a stainless steel housing. Turn up to 24 10kgs of food. Suitable with older models as well as PEAK PRIME™ 2.0 & LEDGE PRIME™ 2.0.

#GMG6036
#GMG6038



WOOD-FIRED PIZZA OVEN

Pizza night at home will never be the same after cooking artisan wood-fired pizza right in your backyard. Designed for our grills, the pizza attachment transforms your pellet grill into a high-heat wood-fired oven! Suitable with older models as well as PEAK PRIME™ 2.0 & LEDGE PRIME™ 2.0.

#GMG4023



CAUTION
SURFACE MAY BE HOT

CUSTOM COVERS

SUITABLE FOR BOTH NEW AND OLD MODELS





#GMG6044 Custom Cover for Ledge 2.0

#GMG6045 Custom Cover for Peak 2.0

#GMG6043 Custom Cover for Trek 2.0



PRODUCT CODE: #GMG4024

GREEN MOUNTAIN GRILLS PIZZA PEEL

This pizza peel from Green Mountain Grills is lightweight and features a brand logo engraved on the wooden handle.



PRODUCT CODE: #GMG4111

GREEN MOUNTAIN GRILLS BRANDED GRILL MAT

- Large coverage area - 121 x 91 cm / 48 x 36 in
- Flame and heat-resistant
- Non-slip diamond pattern
- Waterproof and easy to clean and sanitise.



PRODUCT CODE: #GMG6036

GREEN MOUNTAIN GRILLS ROTISSERIE KIT

Extend your pellet grill and start roasting your favourite cuts of meat on the new GMG Rotisserie Kit. Built to withstand the outdoor elements, the 110V motor is enclosed in a stainless steel housing. Turn up to 24 lbs of food.



PRODUCT CODE: #GMG6030

GREEN MOUNTAIN GRILLS SPRITZ BOTTLE

- 250 ml capacity.
- Long-lasting stainless steel durability.
- Great for flavor basting and food moisture.



PRODUCT CODE: #GMG4104

DRIP-EZ GREASE TRAY PACKS FOR GREEN MOUNTAIN GRILLS

Place the stack of 3 liners on your grease tray to collect drippings. As needed, just peel away the top liner for easy cleanup!



CODE DEPENDING ON SIZE

GREEN MOUNTAIN GRILLS COLLAPSIBLE UPPER RACK

Add more cooking room to your grill with this handy collapsible upper rack. * Suitable for all models



CODE DEPENDING ON SIZE

GREEN MOUNTAIN GRILLS UPPER RACK

Extend the cooking area in your GMG grill with this Upper Rack / Smoker Shelf. * Suitable for all models



CODE DEPENDING ON COLOUR

GREEN MOUNTAIN GRILLS TOTE CARRY BAG - TREK

The smooth black cover has heavy-duty carrying handles and a weather-proof zipper to ensure your grill is protected. Two colours - Black & Camo.

GMG HARDWOOD

GREEN MOUNTAIN GRILLS BRAND PELLETS ARE MADE OF 100% KILN-DRIED SAWDUST THAT NEVER TOUCHES THE FLOOR. OUR PELLETS ARE HELD TOGETHER BY THE NATURAL LIGNINS IN THE WOOD AND ARE A LARGER DIAMETER PELLET THAT ALLOWS THEM TO LAST LONGER THAN STANDARD SIZE PELLETS.



GOLD BLEND

28 LBS.

RED OAK
AMERICAN HICKORY
MOUNTAIN MAPLE



TEXAS BLEND

28 LBS.

BLACK OAK
AMERICAN HICKORY
TEXAS MESQUITE



FRUITWOOD BLEND

28 LBS.

ORCHARD CHERRY
AMERICAN BEECH
SWEET PECAN



APPLE BLEND

28 LBS.

RED OAK
AMERICAN HICKORY
APPLE WOOD



100% ALL NATURAL
HARDWOOD
KILN-DRIED SAWDUST. NO ADDITIVES.

**MADE IN
USA**

NEW & IMPROVED PRIME APP IS HERE



RECIPES

ACCESS OUR RECIPE DATABASE FROM THE PALM OF YOUR HAND.



PROFILES

USE OUR PRESET PROFILES OR CREATE YOUR OWN TO SET YOUR SMOKING INTO AUTOPILOT. GRANULAR GRAPHING CAPABILITIES ALLOW YOU TO GRAPH, EXPORT, AND SAVE YOUR COOKS.



PRECISE TEMPS

MAKE TO-THE-DEGREE TEMPERATURE SELECTIONS RAISE YOUR SKILL LEVEL TO SIZZLE SCIENTIST.



SERVER MODE

NEED TO RUN AND DON'T WANT TO RUIN YOUR FOOD? NO SWEAT. USE THE SMART GRILLING SERVER MODE TO ACCESS AND ADJUST YOUR GRILLING TEMPERATURES ANYWHERE, ANYTIME.



Available on the
App Store



ANDROID APP ON
Google play

On the frontier of smart grilling since 2014, GMG is excited to release the new PRIME APP! With a more user friendly interface, more in-depth grill control and smoke management features, wood-fired grilling has never been easier. Stay synced with your smoke from ocean to mountains and back again. Make on-the-go adjustments using WIFI Smart Control Technology. Become your neighborhood's BBQ guru with easy access to hundreds of recipes and grilling profiles at your fingertips!

12V DIRECT POWER



BETTER TEMP CONTROL

The three principles of great BBQ are temperature, temperature & temperature. With 12V Direct Power we can micro-adjust the variable speed fan and auger motors to keep your food at precisely the temperature you need set.

GREATER FUEL ECONOMY

Green Mountain Grills's propriety algorithms control the fuel and oxygen supply to the firebox. This ensures the lowest possible fuel consumption by dispensing only enough pellets to maintain the set temperature and by burning all of those thoroughly. Less waste means lower pellet costs. Now, you can get up to 40 hours of cooking time from a single hopper.

FASTER STARTUPS

12V Direct Power increases the motor RPMs to feed more pellets and more oxygen during startup. We have upgraded our igniters with a fast-heating design. Together, they yield significantly quicker startups and less time to get up to the temperature you want.

