



ZARGES –
Pack.
Transport. Store.
Special solutions.

For over 80 years, the ZARGES brand has stood for constant innovation and first-class quality. As a driver of innovation, we are continuously improving our range of services and creating solutions and products that are strictly designed for your needs. Because, for us, good ideas result from close cooperation with you, our customer.

Our goal is to always provide you, as a professional, with a suitable solution for every challenge, for your safety and efficiency.

More information can be found online at
zargescases.com/applications/military/



ZARGES

» Solutions for defense technology and
police and emergency services



ZARGES – the highest quality for special challenges.

ZARGES has stood for uncompromising quality and continuous innovation for over 80 years. Due to our decades of brand and innovation leadership in the areas of packaging and transportation, as well as in customer solutions, today we are able to provide you with products and services that set market standards in security, protection and ergonomics.

Whether it's for electronics, medical material or other sensitive goods for the military, police or emergency services, ZARGES cases are incredibly light and durable while at the same time, noncorrosive, nonmagnetic, and versatile.

Behind them are decades of experience in designing and constructing reusable packaging, storage and transport cases.

We are continuously optimizing and expanding our product and service portfolios with one great goal in mind: to have a professional and customized logistical solution for any task and situation.

Take a look at the new ZARGES special catalog and discover our high-quality products, unique system solutions and many new items.

If you have any questions, require custom solutions or simply want more information, our service team is always happy to help:

Phone: 704-357-6285

Email: sales@zargesusa.com

www.zargesusa.com

ZARGES quality is continuously tested and verified with certification from renowned external inspection authorities.



Solutions for defense technology and police and emergency services

More about ZARGES	2
Solutions at a glance	4-5

Mitraset® 19" rackmount case from page 6



Mitraset® 19" rackmount case	from pages 8-9
Mitraset® Classic	10-15
Mitraset® Racklite	16-18
Mitraset® Racklite Basic	19
Mitraset® Accessories	20-21
Mitraset® Applications and Custom Solutions	22-27

Custom cases from page 28



K 475 Transport and Storage cases	30-31
Modular cases	32
Y Cases	33
Hood cases	34
RetouR® Collapsible case	35
K 473 Heavy Duty case	36
Large cases	37
Custom solutions	38-39

Standard cases from page 40



K 424 XC Mobile Office	42-43
K 470 Universal case	44-48
Hazardous goods packaging	49
K 470 Plus Universal hood case	50
Paint and labeling	51
K 470 IP 65 and IP 67	52-53
K 410 Aluminum case	54
K 411 Attaché case	55
Testing and certification	56-57

Information and services from page 58

ZARGES subsidiaries	58
---------------------	----





© Taurus Systems GmbH

Airtight custom cases for transporting and storing missiles



Y case: Custom cases for medical material



Secure protection for electronics



K 473 Heavy Duty cases and K 470 Universal cases for air-transportable drinking water preparation systems



K 470 Weapon case – protect against unauthorized access



Hood cases for large medical devices



Protection for medical equipment



Height-adjustable work platforms that adapt to contours for optimal maintenance work

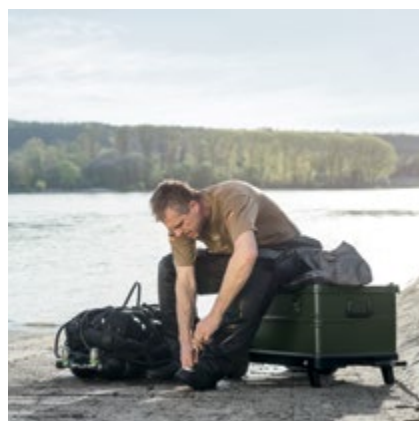

K 424 XC Mobile Office – Mobility on any surface



Mitraset® to carry electronic devices



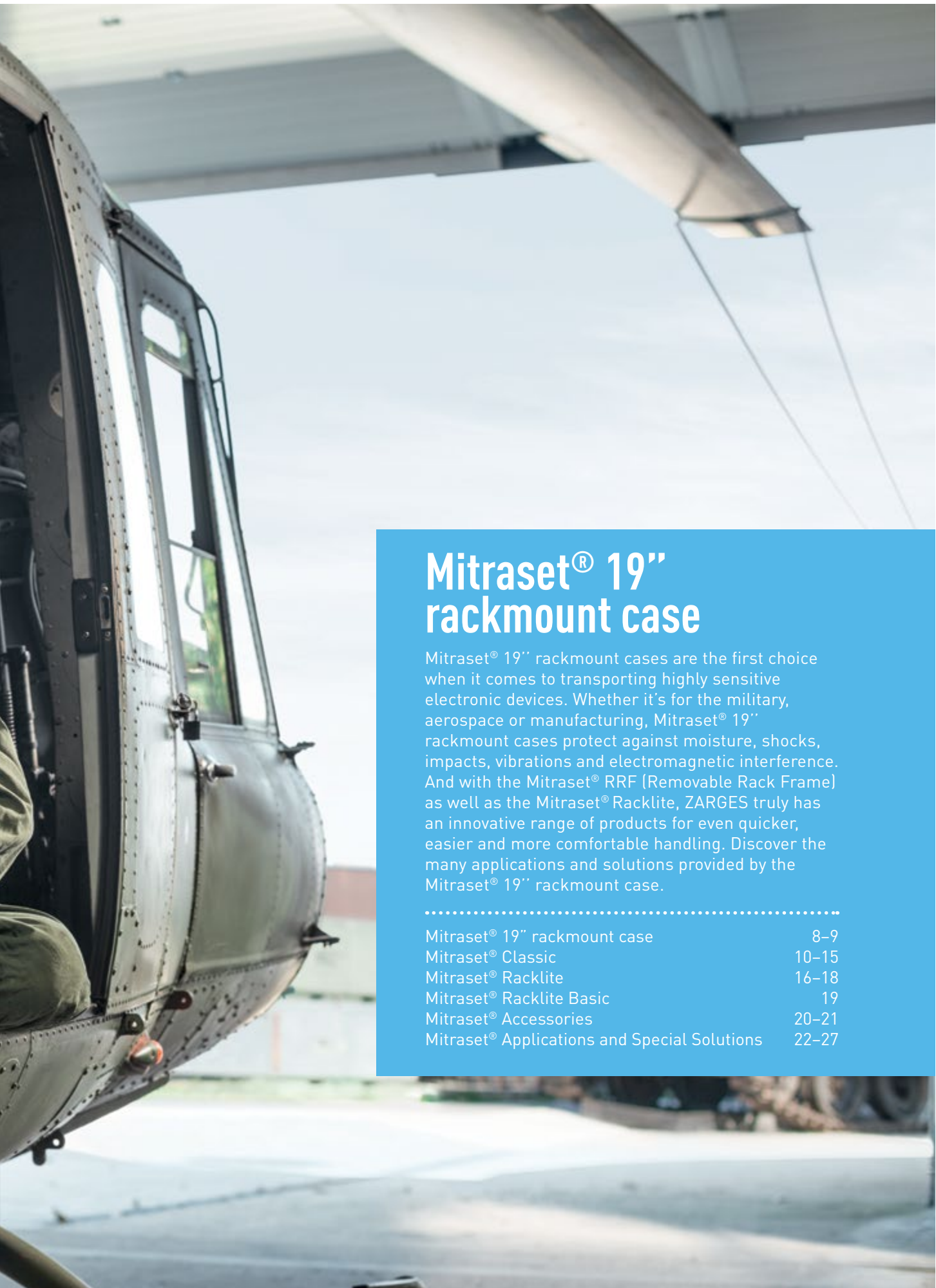

Mitraset® 19" rackmount case

Mitraset® 19" rackmount cases are the first choice when it comes to transporting highly sensitive electronic devices. Whether it's for the military, aerospace or manufacturing, Mitraset® 19" rackmount cases protect against moisture, shocks, impacts, vibrations and electromagnetic interference. And with the Mitraset® RRF (Removable Rack Frame) as well as the Mitraset® Racklite, ZARGES truly has an innovative range of products for even quicker, easier and more comfortable handling. Discover the many applications and solutions provided by the Mitraset® 19" rackmount case.

.....

Mitraset® 19" rackmount case	8-9
Mitraset® Classic	10-15
Mitraset® Racklite	16-18
Mitraset® Racklite Basic	19
Mitraset® Accessories	20-21
Mitraset® Applications and Special Solutions	22-27

Mitraset® 19" rackmount case – superior protection for electronic devices

Mitraset® 19" rackmount cases are made of aluminum and designed to carry electronic devices in a 19" array pursuant to DIN EN 60297-3-100 and EIA-310-E.

Protective functions

- Prevents mechanical stress such as shocks, impacts and vibration.
- Protects against electromagnetic interference and radio waves, lightning, etc., as well as from general environmental influences such as heat, humidity, liquids, dust, etc.

The electronic devices to be protected are placed and screwed into the elastic swing frame, which provides optimal protection.

Primary applications for the Mitraset® rackmount case include:

- Military applications, telecommunications and the electronics industry.
- Traffic infrastructure such as rail safety and traffic control systems.
- Anywhere sensitive electronics need to be used on the move and/or outside of buildings.



1 Cover. 2 Rubber seal. 3 Rackmount case. 4 Swing frame. 5 Sealing collar. 6 Cover. 7 Toggle lock. 8 Floating fastener. 9 Rails. 10 Guide rails. 11 Pressure equalizer (three types available). 12 Handle. 13 Shock dampener. 14 Rubber buffer. 15 Ground strap.

The new Mitraset® 19" rackmount case series

ZARGES has expanded its Mitraset® range of products to accommodate the different demands of transporting and operating electronic devices. The Mitraset® Classic rackmount case is joined by the new Mitraset® Racklite and the Mitraset® Racklite Basic.



Mitraset® 19" rackmount case

Mitraset® Classic



- For loads up to **220 lbs.**
- Higher loads possible on an individual basis.
- 3 to 22 U, nominal depth 8.62 to 38.96 inch.
- Designed according to VG 95 446 or 95 447.
- Meets the highest military specifications.
- Individual layout of dampening elements according to client specifications.
- Custom designs available.

Mitraset® Racklite



NEW

- For loads up to **132 lbs.**
- 3 to 12 U, nominal depth 13.78 to 30.00 inch.
- Standard shock isolation system. Mitigation to custom specifications is available.

Mitraset® Racklite Basic



NEW

- For loads up to **132 lbs.**
- 3 to 12 U, nominal depth 13.78 to 30.00 inch.
- Standard rubber buffer with standardized (non-configurable) performance.
- Like Mitraset® Racklite, without rubber corner components.

Mitraset® Classic – cover, grips, stacking segments



- Upper stacking segments feature recessed areas.
- Standard cases also have protective imprints.
- Side walls feature recesses for drop handles.
- Recesses also suitable for securely installing pressure equalization valve and humidity indicator.
- Cover can be fastened with screws.
- Ergonomic ZARGES comfort handles.

Optional UN hazardous goods certification available



Side views

Setup of grips, stacking feet and recesses for various nominal depths.

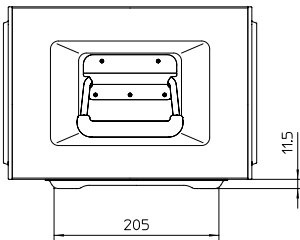

▲ Nominal depth of 8.62 inch

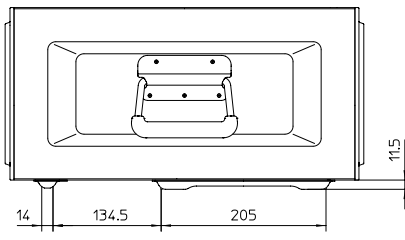

▲ Nominal depth of 13.78 inch

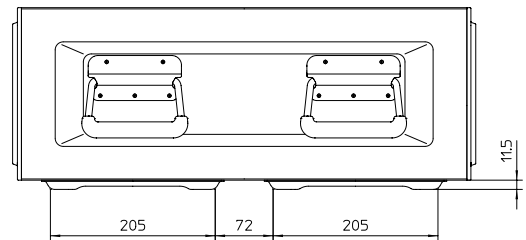

▲ Nominal depth of 18.90 inch

Cases of nominal depths of 8.62 inch, 13.78 inch and 18.90 inch can be stacked with one another.

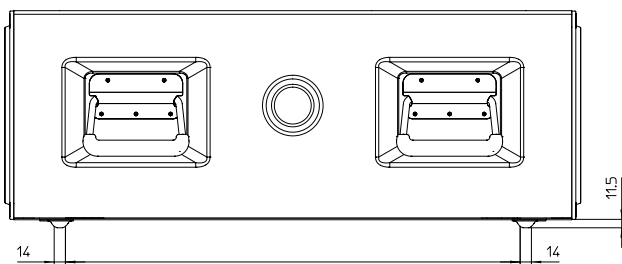

▲ all other depths

Depending on depth



Mitraset® Classic – vibration dampening

Adverse mechanical vibration often occurs during transport and use. This may negatively affect the functionality of electronic components and poses an increased safety risk.

Mitraset® rackmount cases provide the solution for vibration problems in military and aerospace as in manufacturing. They are tested per MIL-STD-810.

For special requirements, a modified Mitraset® rackmount case was successfully tested according to the strict standards of MIL-STD-810 F.

The following diagrams show the inspection specifications per FIGURE 514.5C-3.: Composite wheeled vehicle vibration exposure.

ZARGES can also create custom solutions according to your specifications.



MIL-STD-810 F, FIGURE 514.5 C-3. (MIL-STD-810 F, 1 January 2000, ANNEX C)

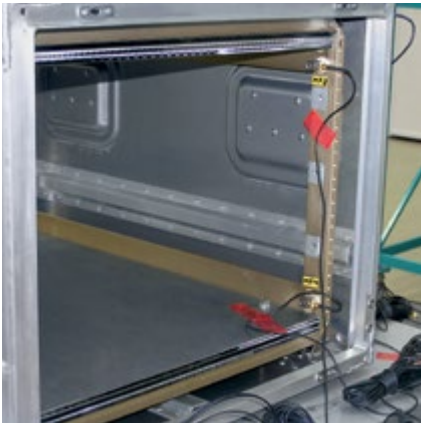
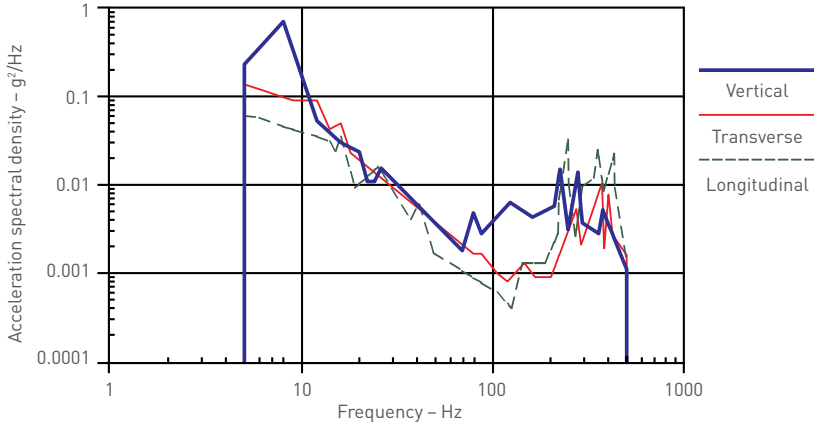

Vibration inducement per MIL-STD-810 F Category 4
Figure 514.5 C-3 Composite wheeled vehicle vibration exposure

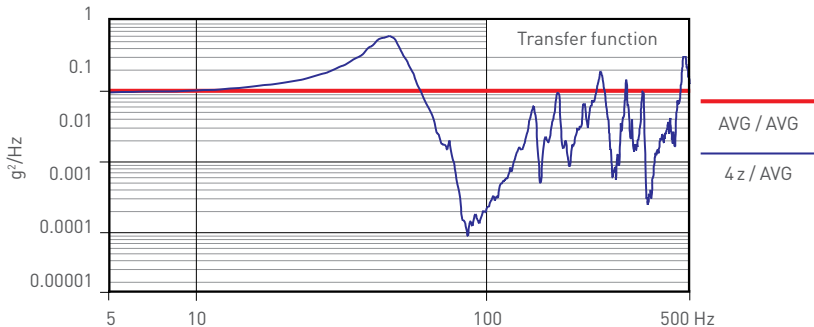
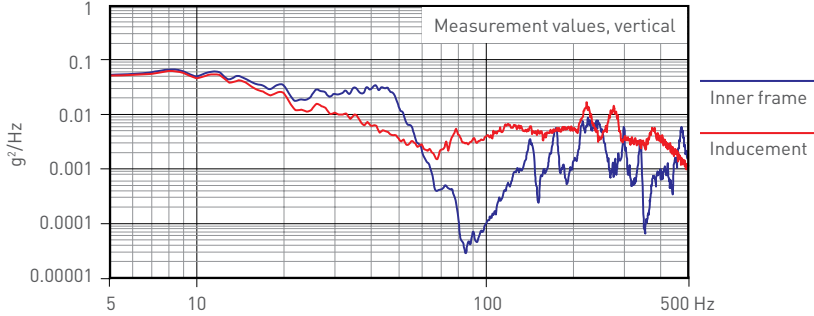

Mitraset® Classic – tests and certifications



Mitraset® 19" rackmount cases have proven their mettle during many tests and military deployments. ZARGES has already received approval for the new VG 95 447 for the Mitraset® Classic. The VG 95 447 defines tests using NATO standard AECTP 400. The withdrawn VG 95 446 defined tests using US MIL-STD-810.

These norms are important standards for military tests:

Shock test	Test 516.3 per MIL-STD-810D-17. The shock test that records dampening is conducted in 6 principal directions, with 3 semi-sinusoidal shock loads each, at acceleration $a = 40\text{ g}$ and pulse duration $t = 7\text{ ms}$.
Handle strength	The test object is to be suspended in a normal position and weighed down so that there is a force of 375 N on each handle. Then the test object is hung individually from each handle and a force of 750 N applied. Test duration: 5 minutes per VG 95 446.
High temperature testing	Test 501.2 per MIL-STD-810 D-3, Procedure I A2. 24 hours, 71° C.
Low temperature testing	Test 502.2 per MIL-STD-810 D-4, Procedure I C2. 24 hours, -51° C.
Temperature change testing	Test 503.2 per MIL-STD-810 D-5. Procedures I to III, 3 × 4 h each at 71°C and -50°C. Test with humid heat. Test 507.2 per MIL-STD-810 D-8, Procedure III.
Vibrational load	1. Test 514.3 per MIL-STD-810 D-15 Figures 514.3-7, 514.3-8 and 514.3-9, depending on vibrational axis, 10 min. per each axis. 2. Resonance determined during vibration under section 1. 3. Vibration per Figure 514.3-36 in the three principal axes, one hour per axis. Sections 1 to 3 are conducted fully in one axis.
Salt fog test	Per MIL-STD-810F Method 509.4, test duration 96 hours.
Fungal infestation	Resistant to fungus per MIL-STD-810F Method 508.5, test duration 28 days.
Leak-tightness	Tested per MIL-STD-810 G Method 506.5 Rain – Procedure I – Rain and Blowing Rain. Wind speed 28 m/s, at least 90 minutes per side. Leak-tightness per IP 65 according to DIN EN 60529:1992. Dustproof and jetproof.
Electromagnetic shielding	Shielding effectiveness test per MIL-STD-285.
Tested according to GGVS regulations	Hazardous goods approval Packaging group II per ADR / RID / IATA-DGR and IMBG-Code. Details on page 49.

Mitraset® Classic RRF (Removable Rack Frame)

With the Mitraset® Classic RRF (Removable Rack Frame), the 19" swing frame can be removed at any time, quickly and without tools, even if 19" racks are already inserted.

This means when removing the swing frame, systems and cables can be installed easily and comfortably, since the equipment is accessible from all sides. Rackmount cases with removable swing frame are used for prototypes and as cases for components that often need to be switched.

A special surface coating ensures that the swing frame slides easily. The standard case is equipped with a bonding system (grounding system). The compact design means that the entire nominal height of the Mitraset® Classic RRF is available for installation.

Compared to the products of competitors, ZARGES Mitraset® rackmount cases do not sacrifice any rack height for security; even with added locks, the exterior dimensions remain unchanged. Mitraset® RRF cases have successfully passed the shock and vibration tests in accordance with MIL-STD-810 F Method 514.5.

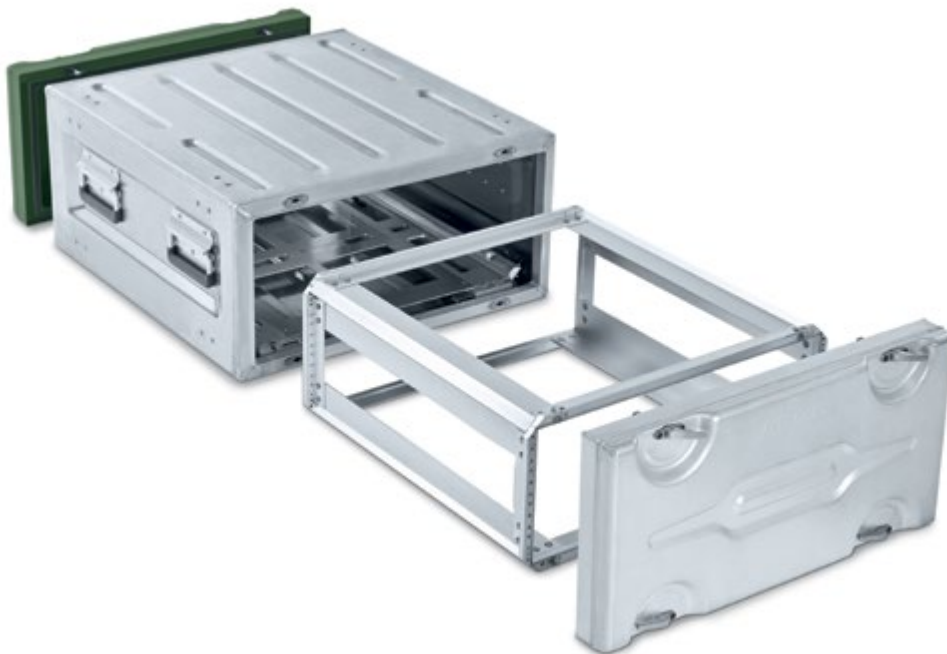

The Mitraset® RRF with removable swing frame simplifies integration because it gives you unfettered access to the 19" racks.

Cable and plug can be installed easily. After finishing the installation process, the entire isolating frame is pushed into the case and secured. The case is ready to ship within seconds.

The Mitraset® RRF is only available in the Mitraset® Classic version.

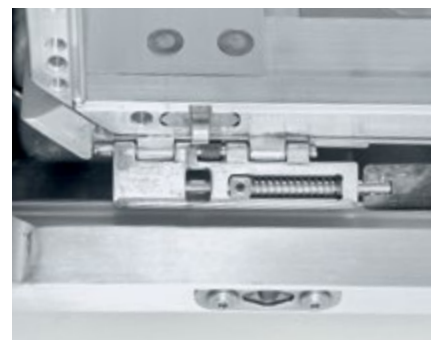

Mitraset® Classic

Cases

SKU	Installation height (U)	Nominal Depth (inches)	Outer dimensions without cover, H x W x D, (approx. inches)	Weight without lids (pounds)	Weight with 2 Lids (approx. lbs.)
45702	3	8.62	8.44 × 21.02 × 11.93	14.55	22.93
45704	3	13.78	8.44 × 21.02 × 17.09	18.96	27.34
45706	3	18.90	8.44 × 21.02 × 22.20	23.59	31.97
45803	3	24.02	8.44 × 21.02 × 27.32	29.76	38.14
45863	3	30.00	8.44 × 21.02 × 33.70	35.71	44.09
45708	4	8.62	10.20 × 21.02 × 11.93	15.43	24.69
45710	4	13.78	10.20 × 21.02 × 17.09	19.84	29.10
45712	4	18.90	10.20 × 21.02 × 22.20	24.47	33.73
45804	4	24.02	10.20 × 21.02 × 27.32	31.09	40.34
45864	4	30.00	10.20 × 21.02 × 33.70	37.04	46.30
45714	5	8.62	11.95 × 21.02 × 11.93	16.09	26.23
45716	5	13.78	11.95 × 21.02 × 17.09	20.50	30.64
45718	5	18.90	11.95 × 21.02 × 22.20	25.13	35.27
45805	5	24.02	11.95 × 21.02 × 27.32	32.41	42.55
45865	5	30.00	11.95 × 21.02 × 33.70	38.36	48.50
45720	6	8.62	13.70 × 21.02 × 11.93	16.53	27.56
45722	6	13.78	13.70 × 21.02 × 17.09	21.16	32.19
45724	6	18.90	13.70 × 21.02 × 22.20	26.23	37.26
45806	6	24.02	13.70 × 21.02 × 27.32	33.51	44.53
45866	6	30.00	13.70 × 21.02 × 33.70	39.46	50.49
45726	7	8.62	15.45 × 21.02 × 11.93	17.20	29.10
45728	7	13.78	15.45 × 21.02 × 17.09	22.05	33.95
45730	7	18.90	15.45 × 21.02 × 22.20	26.90	38.80
45807	7	24.02	15.45 × 21.02 × 27.32	35.05	46.96
45867	7	30.00	15.45 × 21.02 × 33.70	41.01	52.91
45732	8	8.62	17.20 × 21.02 × 11.93	18.08	30.42
45734	8	13.78	17.20 × 21.02 × 17.09	22.71	35.05
45736	8	18.90	17.20 × 21.02 × 22.20	27.78	40.12
45808	8	24.02	17.20 × 21.02 × 27.32	36.60	48.94
45868	8	30.00	17.20 × 21.02 × 33.70	42.55	54.89
45738	9	8.62	18.96 × 21.02 × 11.93	18.52	31.75
45740	9	13.78	18.96 × 21.02 × 17.09	23.59	36.82
45742	9	18.90	18.96 × 21.02 × 22.20	28.66	41.89
45809	9	24.02	18.96 × 21.02 × 27.32	37.70	50.93
45869	9	30.00	18.96 × 21.02 × 33.70	43.65	56.88
45744	10	8.62	20.71 × 21.02 × 11.93	18.96	33.07
45746	10	13.78	20.71 × 21.02 × 17.09	24.25	38.36
45748	10	18.90	20.71 × 21.02 × 22.20	29.32	43.43
45810	10	24.02	20.71 × 21.02 × 27.32	38.58	52.69
45870	10	30.00	20.71 × 21.02 × 33.70	44.53	58.64
45750	11	8.62	22.46 × 21.02 × 11.93	19.40	33.95
45752	11	13.78	22.46 × 21.02 × 17.09	24.91	39.46
45754	11	18.90	22.46 × 21.02 × 22.20	30.20	45.41
45811	11	24.02	22.46 × 21.02 × 27.32	54.45	54.45
45871	11	30.00	22.46 × 21.02 × 33.70	45.86	60.41
45756	12	8.62	24.21 × 21.02 × 11.93	19.84	35.27
45758	12	13.78	24.21 × 21.02 × 17.09	25.57	41.01
45760	12	18.90	24.21 × 21.02 × 22.20	31.09	46.52
45812	12	24.02	24.21 × 21.02 × 27.32	41.01	56.44
45872	12	30.00	24.21 × 21.02 × 33.70	46.96	62.39
45814	14	24.02	28.25 × 21.02 × 64.57	46.42	60.61
45874	14	30.00	28.25 × 21.02 × 70.56	52.36	65.12
45816	16	24.02	31.22 × 21.02 × 27.32	64.57	64.59
45876	16	30.00	31.22 × 21.02 × 33.70	70.56	70.55

Important: Clearance dimensions of case frame = exterior dimensions minus 1.73 inch, weight does not include cover and paint

- Additional sizes available by request.
- Case height with stacking foot = external dimensions (nominal) + 0.45 inch.
- Cover depth = 2.48 inch, depth of custom covers depends on specifications.

Mitraset® Classic

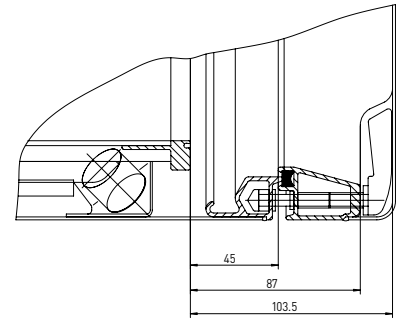

Swing space measured

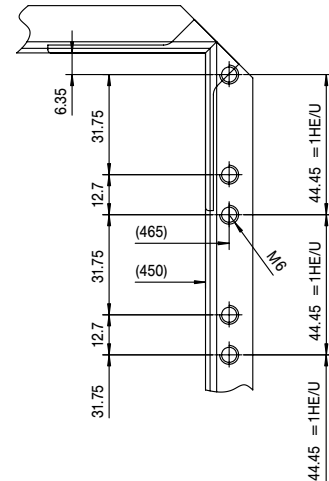

Drill pattern measured

Inner frame

- Insert width 17.71 inch.
- Insert height 1 U = 1.75 inch.
- Insert depths (nominal) 8.62/13.78/18.90/24.02 inch or custom depths.

Covers

Lid	Outer dimensions H x W x D, (approx. inches)	Weight per cover, (approx lbs)
3 U	8.44 × 21.02 × 2.51	4.19
4 U	10.2 × 21.02 × 2.51	4.63
5 U	11.95 × 21.02 × 2.51	5.07
6 U	13.7 × 21.02 × 2.51	5.51
7 U	15.45 × 21.02 × 2.51	5.95
8 U	17.2 × 21.02 × 2.51	6.17
9 U	18.96 × 21.02 × 2.51	6.61
10 U	20.71 × 21.02 × 2.51	7.05
11 U	22.46 × 21.02 × 2.51	7.27
12 U	24.21 × 21.02 × 2.51	7.71
14 U	28.25 × 21.02 × 2.51	8.38
16 U	31.22 × 21.02 × 2.51	9.04



Important: Clearance dimensions of case = exterior dimensions minus 2.13 inch.

Mitraset® Racklite



The Mitraset® Racklite is ZARGES' light case series with 19" swing frames for low to medium installation weights. Equipped with standard rubber buffers, performance not configurable.

- The simple setup process for standard dampeners allows for weight-optimized cases for insert weights up to 132.24 lbs
- The 6U 24.02 inch size achieves a weight reduction of 15% compared to the Mitraset® Classic.
- Quick and secure cover locking using well-proven comfort fasteners with spring anti-opening feature.
- The new corner components made from thermoplastic elastomer (TPE) allow for improvements to paint protection and stackability, as well as in drop tests per MIL-STD 810 Method 516.6, Procedure IV.
- Equipped with comfort spring handles for ergonomic handling and loads up to 110.20 lbs.
- IP 65 protection in accordance with DIN EN 60529 and IEC 34-5/529 via welded case and cover with circumferential seal.
- Shielding effectiveness test per MIL-STD-285.
- The vibration-reducing properties of the case are determined by ZARGES.
- Suitable for industrial and other applications up to 132.24 lbs.
- Mitraset® Racklite was tested according to MIL-STD-810G, Figure 514.6C-1, Common carrier (US highway truck vibration exposure).



Mitraset® Racklite

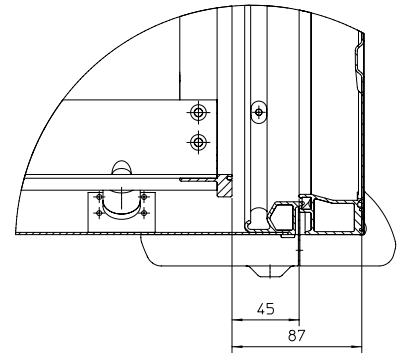

Swing space measured

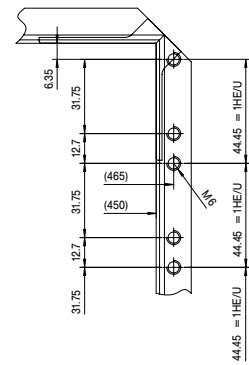

Drill pattern measured



Mitras[®] Racklite

Cases

SKU	Installation height (U)	Nominal depth, (inches)	Outer dimensions without cover, H x W x D, (approx. inches)	Weight without lids (approx. lbs.)	Weight with 2 Lids (approx. lbs.)
45893	3	13.78	10.69 × 23.27 × 18.43	20.06	29.76
45903	3	18.90	10.69 × 23.27 × 23.54	23.15	32.85
45913	3	24.02	10.69 × 23.27 × 28.66	26.01	35.71
45923	3	30.00	10.69 × 23.27 × 34.65	29.32	39.02
45894	4	13.78	12.44 × 23.27 × 18.43	21.38	31.97
45904	4	18.90	12.44 × 23.27 × 23.54	24.69	35.27
45914	4	24.02	12.44 × 23.27 × 28.66	27.56	38.14
45924	4	30.00	12.44 × 23.27 × 34.65	30.86	41.44
45895	5	13.78	14.19 × 23.27 × 18.43	22.27	33.73
45905	5	18.90	14.19 × 23.27 × 23.54	25.57	37.04
45915	5	24.02	14.19 × 23.27 × 28.66	28.44	39.9
45925	5	30.00	14.19 × 23.27 × 34.65	31.97	43.43
45896	6	13.78	15.94 × 23.27 × 18.43	22.93	34.83
45906	6	18.90	15.94 × 23.27 × 23.54	26.23	38.14
45916	6	24.02	15.94 × 23.27 × 28.66	29.32	41.22
45926	6	30.00	15.94 × 23.27 × 34.65	33.07	44.97
45897	7	13.78	17.70 × 23.27 × 18.43	23.59	36.37
45907	7	18.90	17.70 × 23.27 × 23.54	27.12	39.9
45917	7	24.02	17.70 × 23.27 × 28.66	30.2	42.99
45927	7	30.00	17.70 × 23.27 × 34.65	33.95	46.74
45898	8	13.78	19.45 × 23.27 × 18.43	24.25	37.92
45908	8	18.90	19.45 × 23.27 × 23.54	28	41.67
45918	8	24.02	19.45 × 23.27 × 28.66	31.3	44.97
45928	8	30.00	19.45 × 23.27 × 34.65	35.05	48.72
45899	9	13.78	21.20 × 23.27 × 18.43	25.13	39.68
45909	9	18.90	21.20 × 23.27 × 23.54	28.88	43.43
45919	9	24.02	21.20 × 23.27 × 28.66	32.19	46.74
45929	9	30.00	21.20 × 23.27 × 34.65	36.15	50.7
45900	10	13.78	22.95 × 23.27 × 18.43	25.79	40.78
45910	10	18.90	22.95 × 23.27 × 23.54	29.54	44.53
45920	10	24.02	22.95 × 23.27 × 28.66	33.07	48.06
45930	10	30.00	22.95 × 23.27 × 34.65	37.04	52.03
45901	11	13.78	24.7 × 23.27 × 18.43	26.45	42.33
45911	11	18.90	24.7 × 23.27 × 23.54	30.42	46.29
45921	11	24.02	24.7 × 23.27 × 28.66	33.95	49.82
45931	11	30.00	24.7 × 23.27 × 34.65	38.14	54.01
45902	12	13.78	26.46 × 23.27 × 18.43	27.34	44.09
45912	12	18.90	26.46 × 23.27 × 23.54	31.3	48.06
45922	12	24.02	26.46 × 23.27 × 28.66	34.83	51.59
45932	12	30.00	26.46 × 23.27 × 34.65	39.24	55.99

Important: Clearance dimensions of case profile = external dimensions minus 1.73 inches. Clearance width: External dimensions minus 3.98 inches. Clearance height: External dimensions minus 3.98 inches. × Weight does not include cover and paint. Case dimensions include corner elements.

Covers

SKU	Lid	Outer dimensions H x W x D, (approx. inches)	Weight (approx lbs)
45933	3 U	10.69 × 23.27 × 2.17	4.85
45934	4 U	12.44 × 23.27 × 2.17	5.29
45935	5 U	14.19 × 23.27 × 2.17	5.73
45936	6 U	15.94 × 23.27 × 2.17	5.95
45937	7 U	17.70 × 23.27 × 2.17	6.39
45938	8 U	19.45 × 23.27 × 2.17	6.83
45939	9 U	21.20 × 23.27 × 2.17	7.27
45940	10 U	22.95 × 23.27 × 2.17	7.50
45941	11 U	24.70 × 23.27 × 2.17	7.94
45942	12 U	26.46 × 23.27 × 2.17	8.38

Mitraset® Racklite Basic



The Mitraset® Racklite Basic is the light case series with 19" swing frames for low to medium installation weights. The Mitraset® Racklite Basic omits the corner elements of the Mitraset® Racklite.

- Considerably more compact dimensions.
- Mitraset® Racklite Basic can be stacked with the Mitraset® Classic series.
- IP 65 protection in accordance with DIN EN 60529 and IEC 34-5/529, welded case and cover with circumferential seal.
- Lower weight than the Mitraset® Classic and Mitraset® Racklite.
- Custom depths for covers available.
- Comfort spring handles provide the best grip.
- Shielding values comparable to the Mitraset® Classic and Mitraset® Racklite.



Dimensions of Mitraset® Racklite Basic:

Eliminating the corner elements of the Mitraset® Racklite reduces the

- height by 1.79 inch.
- width by 0.91 inch.
- depth including cover by 1.69 inch.

The weight including cover is reduced by 4.85 lbs.



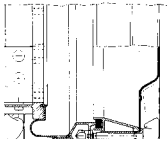

Accessories

Sealing collar		
		Per IP 65 requirements for operation when the cover is open, use sealing collars according to the table below. Special HF-proof design available.
for Mitraset® type	Standard SKU	HF-proof SKU
3 U	37053	37083
4 U	37054	37084
5 U	3 055	37085
6 U	37056	37086
7 U	37057	37087
8 U	37058	37088
9 U	37059	37089
10 U	37060	37090
11 U	37061	37091
12 U	37062	37092
14 U	37064	37094
16 U	345093	37093

Pressure equalization		SKU
	Permanent pressure equalization through membrane.	60891

Humidity controls		SKU
	Humidity indicator per TL 6685-0008 (VG 95 617). Desiccants upon request.	316887

Lifting eye		SKU
	Rivet nut and eyebolts (M8) for crane transport. Load capacity of up to 300 kg.	339956

Pressure equalization		SKU
	Automatic pressure equalization per GV 95 618. Pressure automatically equalized when specified pressure difference reached. This protects the case from damage caused by pressure differentials at all times. Pressure equalization can also be activated at the touch of a button, when opening the case for instance.	316886

Lock assembly		SKU
	Pressure cylinder lock. Two locks diagonal to two dog-bolt latches with two locks. Only for Mitraset® Classic.	342110

Pressure equalization		SKU
	Manual, bolt must be released when the case is transported by air. Sealed only when bolt is latched.	346457

Ground mounting		SKU
	Accomplished with additional fasteners (M8 threading) in the stacking feet. For Mitraset® Classic and Mitraset® RackLite Basic.	by request

Pressure equalization		SKU
	Manual pressure equalization valve. Pressure is equalized by pressing the button, for example to open the case.	320060

Cable holder		SKU
	Depending on height: Set consists of two to four mounting brackets with Velcro straps. Mounted on inner side of cover.	by request

Accessories

<p>Guide rails</p>  <p>Available for all nominal depths. Two attachment styles available.</p> <ul style="list-style-type: none"> - Infinitely variable, tightened with screws. - Permanently riveted per client instructions. 	<p>SKU</p> <p>by request</p>	<p>Pull-out Drawer</p>  <p>Covering available. With telescopic rails. Suitable for holding drawers, shelves, etc.</p> <p>Available at various heights and nominal depths.</p>	<p>SKU</p> <p>by request</p>
<p>Desiccant shelf</p>  <p>U nominal depth 8.62 inch. For installation in swing frame. Also available in version for cover installation (not pictured). Desiccants available by request.</p>	<p>SKU</p> <p>353017</p>	<p>Pouch</p>  <p>Outer dimensions of pouch, small: approx. 7.28 x 5.31 x 1.97 inch</p> <p>Outer dimensions of pouch, large: approx. 18.9 x 9.92 x 1.97 inch, available from 7 U.</p>	<p>SKU</p> <p>322768</p> <p>340934</p>
<p>Louvered panel</p>  <p>Dimensions approx. 9.06 x 4.72 inch, five openings. Effective ventilation of 10.2 in².</p> <p>Other dimensions available by request.</p>	<p>SKU</p> <p>334699</p>	<p>Keyboard bracket</p>  <p>Foam insert in cover with Velcro fastener, available from 6 HE.</p>	<p>SKU</p> <p>by request</p>
<p>Stand</p>  <p>Variable height, with four legs. With legs removed, stackable with carrying cases, includes captive attachment fixtures, for all sizes.</p>	<p>SKU</p> <p>by request</p>	<p>Mitraset® with case connectors</p>  <p>To securely connect stackable Mitraset® cases.</p> <p>For Mitraset® Classic and Mitraset® Racklite Basic.</p>	<p>Order no.</p> <p>369441</p>

The accessories shown here are compatible with the entire Mitraset® family of products.



HF shielding



Honeycomb filter in cover

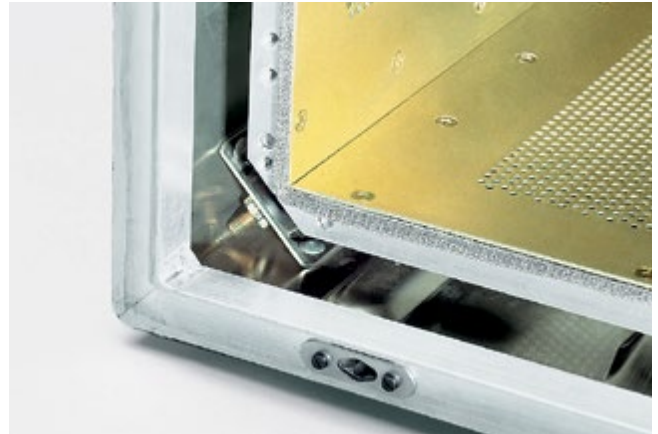

Case equipped with chromated perforated metal plate and HF sealing cord in the swing frame

Standard aluminum Mitraset® 19" rackmount cases provide considerably more HF shielding than plastic cases. This can be improved further through special means, as needed.

For cases with closed covers:

- By using a special cover seal.

For cases with open covers:

- By paneling the standard inner frame with metal plates on four sides. Panels are selectively perforated to improve air circulation. In addition, the edges on the front and rear side are equipped with an HF sealing cord.
- By inserting a sealing collar made from conductive material between the case and swing frame.

For shielded cases, we recommend chromated cases, covers and swing frames. ZARGES also offers chromium(VI) free coatings.

Example of shielding effectiveness per MIL-STD-285:

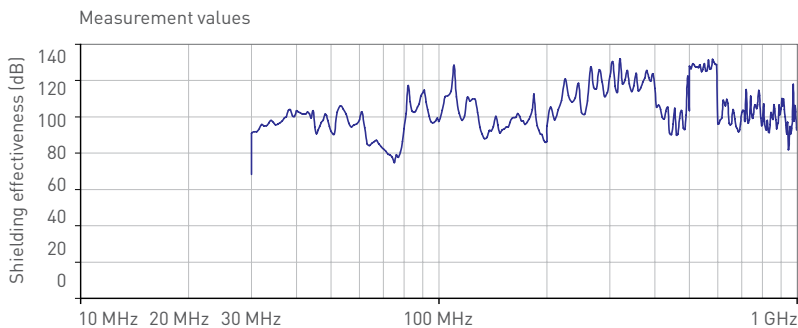

Measurement on a 9 U case, 13.78 inch nominal depth with shielded inner frame



Wire cable damper

For especially high loads or vibration-dampening requirements, the Mitraset® 19" frame is suspended via wire cable dampers at a 45° angle. Outer dimensions are increased accordingly due to the enlarged swing frame. This special version is only available for Mitraset® Classic.



Mitraset® wire cable damper



Custom solutions



Mitraset® Classic with specially louvered cover plates and deeply recessed connector panel



Mitraset® Classic with custom edge reinforcement



Cover with recessed connector panel



Mitraset® Racklite: Cover with connector panel and door for transport protection. Side opening for ventilator



Mitraset® Classic in custom dimensions 19 1/2" with attached connector panel and sealing collar



Custom Mitraset® Classic with hinged cover and supports and custom Flecktarn finish

Applications, mobility and custom solutions

Whether it's for aircraft, vehicles or special applications, ZARGES provides the perfect cases and solutions for a myriad of applications, including transport solutions, custom cushioned cases, dust and water protection, or specially reinforced products to meet demanding requirements.

In addition to the wide range of standard accessories, the Mitraset® 19" rackmount case offers many client-specific custom solutions. Here are some examples.





Testing equipment for military aircraft hydraulic system



Anti-IED electronic system in Mitraset® Classic rackmount case with special reinforcement and custom cover, operated from a vehicle



Custom front plate with sealing collar for IP 65 protection even if cover is removed



Mitraset® Classic with custom cover featuring special openings and chromated swing frame



Four-caster mobile solution for case gross weights up to 220 lbs.



Handy two-wheel mobile solution for case gross weights up to 77 lbs.

Heat management

Mitraset® 19" rackmount cases are the perfect solution for managing extreme temperature environments

Heat dissipation in watts under various operating conditions

Installation height	Nominal depth, (approx. inch)	1 Individual case freestanding watts	2 Rear wall attached watts	3 Case in middle of stack watts
3 U	8.62	72	59	46
	13.78	86	73	53
	18.90	100	87	59
	24.02	114	101	65
4 U	8.62	82	66	56
	13.78	97	81	63
	18.90	112	97	71
	24.02	128	112	79
5 U	8.62	91	73	65
	13.78	108	90	74
	18.90	124	106	83
	24.02	141	123	92
6 U	8.62	101	80	75
	13.78	119	98	85
	18.90	137	116	95
	24.02	155	134	106
7 U	8.62	110	87	85
	13.78	130	106	96
	18.90	149	125	108
	24.02	168	145	119
8 U	8.62	120	94	94
	13.78	141	114	107
	18.90	161	135	120
	24.02	182	155	133
9 U	8.62	130	101	104
	13.78	151	123	118
	18.90	173	144	132
	24.02	195	166	146
10 U	8.62	139	108	113
	13.78	162	131	129
	18.90	185	154	144
	24.02	209	177	160
11 U	8.62	149	115	123
	13.78	173	139	140
	18.90	198	164	156
	24.02	222	188	173
12 U	8.62	158	122	133
	13.78	184	147	151
	18.90	210	173	169
	24.02	236	199	187
14 U	24.02	263	220	214
16 U	24.02	290	242	241

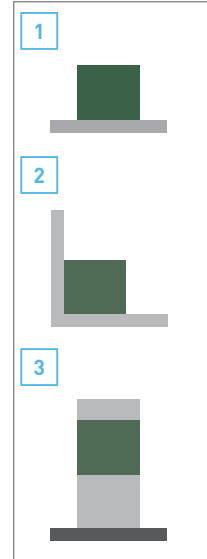

Details

The reference values calculated in the table are influenced by various factors, such as:

- Paint material and color.
- Airflow within interior.
- Site and location of case.
- Influence from neighboring cases.
- Weather and climate conditions.

The reference values in the table were calculated for $\Delta T 36^\circ F$, given in watts. (All values are for closed cases.)

Mitraset® 19" carrying case: client solutions with air-conditioning

The use of 19" rackmount cases often requires additional air-conditioning. To accommodate these needs, ZARGES provides special adjustable cases for air-conditioning systems. Sections for plugs, ventilation plates or the ZARGES heat-exchanging cover are included.

Heat exchanging cover

The ZARGES heat-exchanging cover guarantees IP 65 protection by employing two independent air circuits. Robust ventilators ensure a constant exchange of air. Heat from both circuits is transferred to a specially designed heat exchanger within the cover.

Heat exhaust depends on temperature conditions as well as the site and location of the case. ZARGES is able to develop custom solutions according to client specifications.

Client example for compressor-based air-conditioning solutions

Air-conditioning systems are only connected to Mitraset® as necessary. The system is transported in its own vibration-tested transport case with custom foam inserts.



Decentralized server segments in Mitraset® Classic rackmount cases with air-conditioning device



Adapting an air-conditioning device

© photos: ESG Elektroniksystem- und Logistik-GmbH

Client example for Peltier-based air-conditioning solutions



Heating and cooling units can be adjusted to the cover, case or the swing frame





Custom cases

Special tasks require special solutions. Behind ZARGES custom cases are decades of experience in designing and constructing high-quality packaging solutions. Whether it is a heavy duty case for machines and motors, a large case for missiles and components, or custom packaging for electronics, medical material and other sensitive materials: ZARGES custom cases are designed for special challenges and purposes, even under the most difficult transportation and environmental conditions.

.....

K 475 Transport and Storage cases	30–31
Modular cases	32
Y Cases	33
Hood cases	34
RetouR® Collapsible cases	35
K 473 Heavy Duty cases	36
Large cases	37
Custom solutions	38–39

K 475 Transport and Storage cases



Transport and storage cases from the K 475 series are high-quality reusable packaging options. They are designed as vapor-proof protective packaging for sensitive systems and devices. The cases come in either the dimensions of the standard preferred series version under VG 95 613 or in special sizes according to individual requirements.

Upon request, K 475 custom cases are available with special foam inserts, holders and other additional options, upon request.



Stacking corners



Cover seal



Bottom corner



HF sealing cord



Top frame



Humidity indicator/pressure equalization valve



Details

- Vapor-proof, stackable custom reusable packaging made from noncorrosive aluminum in accordance with TL 8115-0047.
- Case seal welded, IP 67 tightness.
- Durable stacking corners on bottom and cover.
- Removable cover with circumferential seal.
- ZARGES snap fasteners with protection against bursting open.
- Ergonomic, highly durable spring handles.
- Pressure equalization valve and humidity indicator.
- HF shielding available.

K 475 Transport and Storage cases



SKU	Overall Dimensions L x W x H, (approx. in)	Clear Internal Dimensions L x W x H, (approx. in)	Volume (approx. cu in)	Weight (approx. lbs)
45133	15.7 x 15.7 x 11.8	12.9 x 12.9 x 10.4	2075	12.2
45135	19.7 x 19.7 x 15.7	18.1 x 18.1 x 14.4	4699	16.5
45138	23.6 x 15.7 x 15.7	20.7 x 12.9 x 14.4	4515	17.2
45141	31.5 x 15.7 x 11.8	28.6 x 12.9 x 10.4	4454	23.6
45145	31.5 x 23.6 x 19.7	28.6 x 20.7 x 18.1	11960	37



Optional UN hazardous goods certification for all sizes.



Custom options

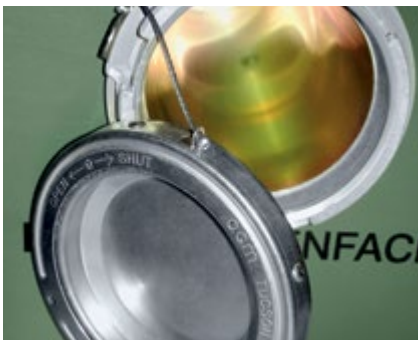

Document compartment

- Manometer
- VA coupling for filling with inert gas
- Foam lining
- Foam inserts according to individual requirements
- HF sealing cord
- Desiccant compartment
- Desiccant cartridges
- Decompression opening
- Pallet base
- Document compartment



Custom built K 475 with VA coupling



VA filling and emptying valve for inert gas



Secure, locked single frame

Modular cases – protection and mobility for medical products



ZARGES modular cases are transport and storage cases for medical material, tools, replacement parts, and more for military and emergency and rescue services. Designed to carry closed ISO standard modules/modular boxes, providing the ability to organize what is needed and quickly swap out empty cases for full ones in storage or on-site.

Details

- High-strength, noncorrosive aluminum alloy.
- Frame with welded plates, splashproof, IP 65 protection.
- Floating fastener mounts.
- Loose cover, connected with four toggle fasteners.
- Stackable via stacking knobs and recesses.
- Two recessed drop handles per end face.
- Circumferential seal on front side.
- Interior has six support rails for a maximum of six modules.
- Outer dimensions (L×W×H, approx. inch):
26.97 x 18.31 x 30.51 including cover.
- Standard version: SKU 45190 (no accessories).

Accessories

- Closed module or module baskets per ISO standards (23.62 x 15.75 inch, heights of 1.97, 3.94, 7.87 inch).
- Polycarbonate (transparent) or ABS (light blue).
- Lateral or longitudinal partition walls.
- Small part modules.

Special accessories in accordance with TL 6545-0055 (see image)

- Two cases usable as work tables.
- Table plate halves are stored in the cover during transport.
- Can be used as a mobile medical station.



Standard version



Special version: Modular case usable as work table



Additional products and solutions from the ZARGES medical catalog can be found at www.zargesmed.com

ZARGES Y Cases



Transport and storage cases in this series are specially designed for military use. All case sizes can be stacked on top of one another. Optional UN hazardous goods certification available in all sizes.



no.	SKU	Type	Overall Dimensions L x W x H, (approx. in)	Clear Internal Dimensions L x W x H, (approx. in)	Volume (approx. cu in)	Weight (approx. lbs)
1	45050	B5 Y	24.2 × 16.5 × 10.6	21.3 × 13.8 × 8.7	2868	14.1
2	45052	B10 Y	24.2 × 16.5 × 20.3	21.3 × 13.8 × 18.3	6102	16.8
3	45055	B20.2 Y	32.9 × 24.2 × 10.6	30.1 × 21.3 × 8.7	6041	25.1
4	45053	B20 Y	32.9 × 24.2 × 20.3	30.1 × 21.3 × 18.3	12875	30.4
5	45054	B20.1 Y	32.9 × 24.2 × 30.0	30.1 × 21.3 × 28.2	19832	37.5
6	45058	B40.2 Y	47.8 × 32.8 × 10.6	45.1 × 30.0 × 8.7	12509	39.7
7	45056	B40 Y	47.8 × 32.8 × 20.3	45.1 × 30.0 × 18.3	26422	48.5
8	45057	B40.1 Y	47.8 × 32.8 × 30.0	45.1 × 30.0 × 28.2	40761	56.7
without image	335597	B10.2 Y	16.5 × 12.0 × 20.3	13.8 × 9.3 × 18.3	2807	11.9

Important: All cases are registered with stock numbers. Clearance dimensions approx. 1.18 inch lower than internal dimensions (length and width). Custom sizes upon request. All standard cases are provided without paint and without labels.

Details

- Transport and storage cases as well as Y series Y cases can be stacked on top of one another.
- Casing joint continuously welded.
- Sturdy cast aluminum stacking corners on cover and base.
- Stacking feet on base with interior and exterior mounting holes.
- Water-tight up to the lower edge of drop handle via interior or silicon sealing on base.
- Resilient base, edge, and cover frame.
- Hinged cover with circumferential seal.
- Removable lid for B40.1 Y, B40.2 Y, and B40 Y.
- Snap fasteners with protection against bursting open.
- IP 54 protection in accordance with DIN 60 529: 1992.

Custom options

- UN-approved hazardous material packaging certification available.
- Red Cross sticker labels on 4 sides and cover in accordance with TL 6545-0055.
- Labeling in accordance with TL 6545-0055.
- For exterior painting, see page 51.
- Variable partition walls.
- Insert bins.
- Base plates.
- Completely nonmagnetic by request.

Optional UN hazardous goods certification for all sizes.



Hood cases – easier handling for heavy devices



Hood transport and storage cases are special cases that are used to package heavy devices. Hood cases, depending on design and version, may be stacked with the standard series of Y cases.

Details

- Base with flat base plate, suitable for attaching fasteners.
- Hood upper section has stacking corners.
- Drop grips on end faces.
- Connect upper and lower section with adjustable fasteners.
- Optionally, the lower section can also be equipped with wood or aluminum pallets for heavy devices.
- The cases can be stacked with Y cases.
- Attached devices can be operated by removing the hood.
- Custom dimensions are available by request.
- We develop project-specific solutions according to your specifications.



Stackable with Y cases



Vapor-proof special design, IP 67



ZARGES pallet cabinets are used when hood cases cannot be used due to low ceiling heights. The device can also be rolled from the case using a ramp. Pallet cabinets are custom designs made according to your specifications. Contact us for more information.

RetouR® collapsible cases for general bulk cargo



Optional UN hazardous goods certification for all sizes.



Collapsible, reusable aluminum alloy packaging for space-saving return transport and storage

- Collapsible by one person using just a few flicks of the wrist.
- Easy handling via interlocking profile with anti-lift device on floor pan and side sections.
- Protective strips.
- Great stability via threefold profile edging on exterior walls.
- Fold ratio 1:3.
- Cover firmly connected to rear wall via floating hinge.
- Edge walls and cover have additional exterior reinforcement profiles.
- Self-locking latches, sealable and/or secured with shackle lock.
- Stacking corners.
- Conveyor-accessible.
- 0.59 inch free space when folded (e.g. for inner lining).

SKU	Clear Internal Dimensions L x W x H (approx. in)	Overall Dimensions L x W x H (approx. in)	Fold dimensions, H (approx. in)	Volume (approx. cu in)	Weight (approx. lbs)
45070	28.7 × 20.9 × 22.4	31.5 × 23.6 × 23.6	5.7	13,485	46.3
45073	44.5 × 28.7 × 29.1	47.2 × 31.5 × 35.4	11.3	37,222	136.7

Note: Aluminum pallets and aluminum protective strips are custom options. SKU 45073: Delivered via wooden pallet and wooden protective strips. Dimensions and weight include flat wooden pallet. Custom sizes upon request.

Special features of collapsible cases

SKU	Description
45070 + 45073	Hinged front longitudinal wall, may be labeled on front
45073	Flat wooden pallets standard

ZARGES also offers a collapsible solution to transport liquid and viscous substances, the RetouR® Inliner collapsible case. Contact us for more information.



K 473 Heavy Duty cases – sturdy for high loads

The K 473 series is especially well suited to high loads, such as heavy machinery, motors and equipment. It provides a robust alternative to the comprehensive K 470 series and protects heavy equipment even under the most difficult transportation and environmental conditions. The perfect balance of weight and protection is achieved through the use of aluminum.

- Robust design, especially well suited to heavy loads.
- Removable cover, equipped with seal.
- Full, sturdy, large-size edge and bottom profile frames, permanently connected with cladding sheet and base plate via high-strength interlocking.
- Circumferential and corner beading for additional structural stability.
- ZARGES comfort hand grips for ergonomic handling and loads up to 110.20 lbs.



Inner packaging for lithium batteries with vermiculite pads and flame-retardant foam

Optional UN hazardous goods certification for all sizes.

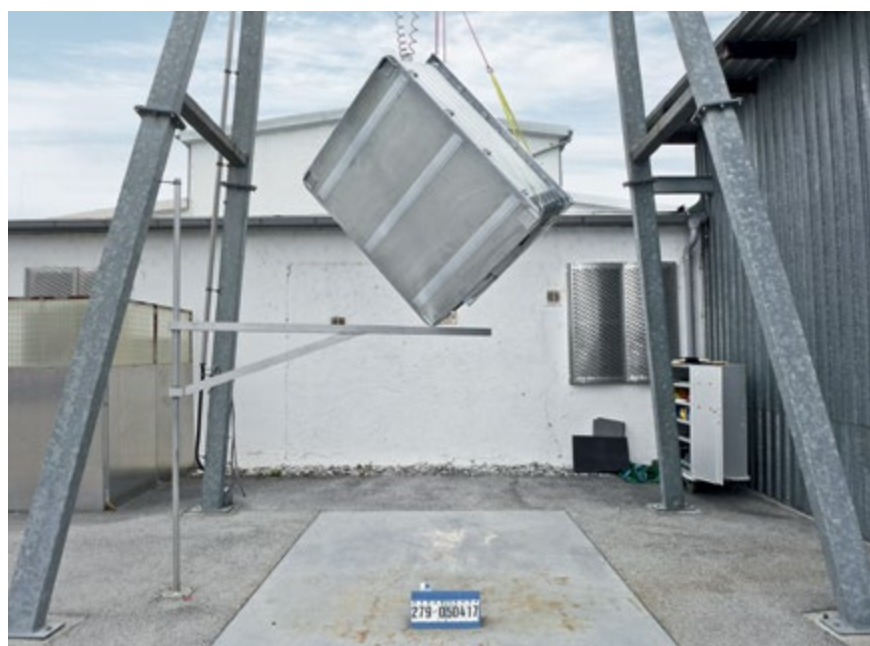

K 473 can also be used to contain hazardous materials for lithium batteries, with a drop test from 1.80 m (= 70.87 inch) and gross weight of 500 kg (= 1,102 lbs)

Optional features

- Stacking corners; cases with and without pallet base can be stacked.
- Aluminum pallet base.
- Hinged cover, two belt straps and circumferential foam sealing in cover (IP 54 tightness).
- Pressure equalization valve and humidity indicator.
- Removable fixed and swivel casters.
- Painting available for all standard versions.
- Can be certified for hazardous materials for loads up to 500 kg (= 1,102 lbs), can also be used for lithium batteries.

Large cases for missiles and components



Large cases for military equipment



Wire cable vibration dampener



KEPD 350 missile before delivery



Security element, rupture disc for protection when environmental pressures suddenly drop

Large cases are specialized cases for use in transporting and storing guided missiles, rockets, drones and more.

ZARGES large cases are designed and manufactured from high-strength aluminum alloy plates and frames. They feature innovations such as shock dampeners, fasteners and handling aids for easy, ergonomic and secure handling. Upon request, tested and approved for hazardous material packaging under UN standards by request, allowing for public transportation.

We can develop a custom solution according to your specifications. Contact us for more information.

Custom solutions for cases and logistics



Custom aluminum cases are individual designs that ZARGES constructs and manufactures in close cooperation with our clients according to their specifications. No matter what the requirement, from a custom version of the K 473 to a highly sophisticated and specialized case, ZARGES custom cases fulfill every demand with creative planning and state-of-the-art manufacturing techniques. Custom cases can be used to store and transport large devices, assemblies and other components for the aerospace industry, as well as industrial products over land, sea and air.

Performance and quality

- Pressure-tight designs.
- Sprayproof designs.
- Protects cargo from shock and vibration.
- Stackable cases.
- Forklift pockets, lifting eyebolts.
- Paint and labeling according to client specifications.
- Custom designs available in any quantity.
- Environmental needs per client specifications.



Special cases with paint



Gas-tight cases to transport satellite components in a nitrogen environment

Special designs for radar and navigation



Photo: Airbus, ASR antenna system

Performance and quality

- Highly exact designs with narrowly tolerated reflective surfaces and racks for electronic attachments and components.
- tolerated reflective surfaces and racks for electronic attachments and components.
- Tested for shock and vibration.
- Pressure-tight design.
- Removable radiation dome.
- Paint free of metallic-oxide.

Highly precise antenna systems are necessary for safe air traffic, and they must function reliably under any conditions. ZARGES provides all of the necessary mechanical components per custom client specifications.

Electronic navigation systems for civilian and military ships, aircraft and ground stations must be able to do their duty even under extreme conditions. ZARGES provides the appropriate components, including radar antennas, antenna housings and reflective geometries, manufactured to strict specifications and resistant to weather and environmental influences.

Special designs for directional radio and satellite antennas

When designing and manufacturing antennas for directional and satellite radio, precision is key. ZARGES has decades of experience from myriad successfully completed projects. Applications include directional radio, TV and telecommunications in fixed and mobile networks (UMTS, etc.). We develop project-specific solutions per your specifications, contact us for more details.

Performance and quality

- Dimensions \varnothing 23.62 - 157.48 inch.
- Special aluminum alloy, painted.
- Pressed, elongated or deep reflector surfaces.
- Accuracy \pm 0.08 inch.
- rms value \leq 0.03 inch
- Wind loads up to max. 124.27 mph



DLR corner reflector





Standard cases for universal use

ZARGES cases fulfill the highest demands of quality, maximum functionality and convincing design. This makes the K 470 Universal case the ideal solution for the secure transport, smart storage and perfect packaging for scores of goods, for manifold applications, and for reliable protection against outside influences.

As an authorized testing authority, ZARGES also offers the perfect cases, in compliance with strict government safety regulations, for packaging and transporting hazardous goods. that comply with strict government safety regulations.

.....

K 424 XC Mobile Office	42-43
K 470 Universal case	44-48
Hazardous goods packaging	49
K 470 Plus hood case	50
Paint and labeling	51
K 470 IP 65 and IP 67	52-53
K 410 Aluminum case	54
K 411 Attaché case	55
Testing and certification	56-57

K 424 XC Mobile Office

Optional UN hazardous goods certification for most sizes.



Standard built-in 2" wheel set



Also stackable with optional wheel kit (SKU 41818) and K 470 and K440 cases

Stability combined with flexibility: the light and indestructible all-surface transportation solution with many accessories:

- Sturdy, mobile aluminum case with ZARGES quality and a long service life.
- Perfect mobility via built-in casters and pull-out handle (SKUs 41810 - 41814) or second spring handle on the end face (SKU 41815).
- Very smooth running via special casters, Ø 1.97 inch, made of polyurethane and polyamide.
- Secure stacking via stacking corners made from impact-resistant plastic and integrated stacking components in the carrier frame. Also stackable with other ZARGES K 470 and K440 cases.
- Lightweight construction maintains a high load capacity of up to 110.2 lbs in total weight.
- Standard version equipped with removable bottom foam inserts made of abrasion-proof PE foam.
- ZARGES comfort fasteners with extremely long service life, equipped with plug locks.
- Versatility through comprehensive range of adjustable interior fittings.
- Optional 4.92 inch wheel set or 8.86 inch off-road wheel set for increased off-road performance.

no.	SKU	Clear Internal Dimensions L x W x H (approx. in)	Overall Dimensions L x W x H (approx. in)	Volume (approx. cu in)	Weight (approx. lbs)	Pull handle	For hazardous goods approval, max. allowable gross weight, (kg)	max. Gross weight (approx. lbs)
1	41810	19.1 × 12.6 × 6.3	21.7 × 15.7 × 9.2	1709	13.9	3-part	25	55.1
2	41811	20.5 × 12.6 × 12.2	23.6 × 15.7 × 15.2	3661	16.1	3-part	25	55.1
3	41812	28.3 × 12.6 × 15.0	31.5 × 15.7 × 17.9	6041	19.8	2-part	35	77.2
4	41813	28.3 × 16.5 × 12.2	31.5 × 19.7 × 15.2	6407	20.9	2-part	35	77.2
5	41814	28.3 × 23.8 × 16.1	31.5 × 27.0 × 19.1	11899	26.5	2-part	35	77.2
6	41815	34.6 × 12.6 × 15.0	37.8 × 15.7 × 17.9	7322	20.9	2nd sprung drop handle	50	110.2
7	41809	14.6 × 11.8 × 15.0	17.7 × 16.1 × 17.9	3051	14.8	3-part	no approval	55.1

K 424 XC – wheel sets and interior fittings



4.92 inch wheel set

- Wheel set with full rubber tires and plastic rim, smooth.
- Increases ground clearance to 1.97 inch.
- With high-quality ball bearings and quick-release axles.
- Tool-less installation with the press of a button on every K 424 XC.
- Can be installed at any time; includes sturdy nylon storage pouch.

SKU	Wheel Ø, (approx. inch)	Suitable for cases
41818	5	all K 470 XC



8.86 inch off road wheel set

- Off-road capable wheels for unlimited mobility on any surface.
- Increases ground clearance to 2.56 inch.
- Easy-to-install support feet allow for level positioning when stationary.

SKU	Wheel Ø, (approx. inch)	Suitable for cases
41819	8.7	41811, 41812, 41815
41832	8.7	41813
41833	8.7	41814



Inner pouch with crosswise dividers

- Sturdy, water-repellent polyester inner pouch.
- Flexible arrangement system with dividers.

SKU	Description	Suitable for Clear Internal Dimensions L x W x H (approx. in)	Quantity of crosswise dividers
41822	Inner pouch for 41810	19.1 × 12.6 × 6.3	4
41823	Inner pouch for 41811	20.5 × 12.6 × 12.2	4
41824	Inner pouch for 41812	28.3 × 12.6 × 15.0	6
41826	Inner pouch for 41813	28.3 × 16.5 × 12.2	6
41827	Inner pouch for 41814	28.3 × 23.8 × 16.1	6
41828	Inner pouch for 41815	34.6 × 12.6 × 15.0	6



Cover pouch

- Durable cover pouch made from black nylon for self-installation.
- Ideal for tablet PCs, cables, small parts or documents.
- Combines protection for parts with order in the case.
- Easily removable.

SKU	Description	Dimensions L x W x H (approx. in)	Suitable for Clear Internal Dimensions min. (in)
41820	Cover pouch, large	16.5 × 10.2 × 1.6	20.5 × 12.6
41821	Cover pouch, small	10.2 × 5.9 × 1.6	11.0 × 8.7



Foam lining

- Universal protection for sensitive objects.
- Durable and non-abrasive lining made of PE foam.
- Bottom and walls made from Plastazote LD 45 (volume 2.8 lb/cu.ft., thickness 0.43 inch).
- Includes bottom foam.
- Cover foam made of studded PU foam.
- Self-adhesive.

SKU	Suitable for Clear Internal Dimensions (approx. in)	For
43889	19.1 × 12.6 × 6.3	41810
43864	20.5 × 12.6 × 12.2	41811
43891	28.3 × 12.6 × 15.0	41812
43892	28.3 × 16.5 × 12.2	41813
43893	28.3 × 23.8 × 16.1	41814
43890	34.6 × 12.6 × 15.0	41815

K 470 Universal case



The K 470 series will win you over with its high-quality aluminum cases in 25 standard sizes and capacities of 793 - 50,589 cu. in. Custom designs available by request.

- Cover with stainless steel hinge, two straps and circumferential foam seal in cover.
- Cast aluminum stacking corners.
- Extremely sturdy with three fully welded aluminum profiles as well as circumferential and corner beading.
- Fully welded profile joints.
- Ergonomic, highly durable spring handles.
- Ergonomic and durable comfort fasteners for at least 20,000 operating cycles.
- Versatile clasp fasteners, lockable and sealable.

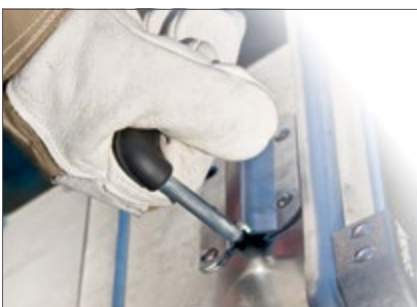

Ergonomic, extra wide ZARGES comfort handles



Safe and easy to operate while wearing gloves



Optional UN hazardous goods certification available in all sizes.

K 470 Universal case

Optional UN hazardous goods certification for all sizes.



no.	SKU	Clear Internal Dimensions* L x W x H (approx. in)	Overall Dimensions L x W x H (approx. in)	Volume (approx. cu in)	Weight (approx. lbs)	For hazardous goods approval, max. allowable gross weight, (kg)	Suitable foam lining
1	40835	12.6 x 8.7 x 5.9	15.7 x 11.8 x 7.1	793	6.0	26.0	43860
2	40677	12.6 x 8.7 x 12.2	15.7 x 11.8 x 13.4	1648	6.8	58.0	43861
3	40810	20.5 x 12.6 x 5.9	23.6 x 15.7 x 7.1	1770	9.3	65.0	43862
4	40568	20.5 x 12.6 x 8.7	23.6 x 15.7 x 9.8	2563	10.6	65.0	43863
5	40678	20.5 x 12.6 x 12.2	23.6 x 15.7 x 13.4	3661	11.0	70.0	43864
6	40564	20.5 x 12.6 x 15	23.6 x 15.7 x 16.1	4455	11.7	75.0	43865
7	40849	20.5 x 20.5 x 8.7	23.6 x 23.6 x 9.8	4089	12.3	65.0	43866
8	40859	20.5 x 20.5 x 15	23.6 x 23.6 x 16.1	7018	14.6	75.0	43867
9	40836	20.5 x 20.5 x 22.8	23.6 x 23.6 x 24	10679	17.2	94.0	43868
10	40837	22.4 x 15.7 x 17.7	25.6 x 18.9 x 18.9	7079	14.3	70.0	43869
11	40839	22.4 x 20.9 x 17.3	25.6 x 24 x 18.5	9032	16.5	83.0	43871
12	40841	26 x 16.9 x 15	29.1 x 20.1 x 16.1	7384	15.7	71.0	43873
13	40842	26 x 24 x 13.4	29.1 x 27.2 x 14.6	9154	18.1	84.0	43874
14	40843	26 x 24 x 16.9	29.1 x 27.2 x 18.1	11595	19.2	100.0	43875
15	40565	28.3 x 20.5 x 15	31.5 x 23.6 x 16.1	9581	22.1	102.0	43877
16	40566	28.3 x 20.5 x 22.8	31.5 x 23.6 x 24	14585	26.5	126.0	43878
17	40844	29.5 x 17.7 x 20.5	32.7 x 20.9 x 21.7	11900	23.6	103.0	43879
18	40845	34.3 x 17.7 x 15.7	37.4 x 20.9 x 16.9	10557	24.7	93.0	43880
19	40846	34.3 x 24 x 17.7	37.4 x 27.2 x 18.9	15805	30.0	115.0	43881
20	40567	36.2 x 16.5 x 15	39.4 x 19.7 x 16.1	9886	24.0	65.0	43882
21	40847	44.1 x 12.6 x 5.9	47.2 x 15.7 x 7.1	3661	19.2	50.0	43887
22	40580	44.1 x 28.3 x 18.9	47.2 x 31.5 x 20.1	25325	44.1	183.0	43884
23	40848	52 x 14.6 x 8.7	55.1 x 17.7 x 9.8	7262	25.1	65.0	43888
24	40875	59.8 x 20.5 x 18.3	63 x 23.6 x 19.5	24165	55.1	150.0	43885
25	40876	63.8 x 28.3 x 26.4	66.9 x 31.5 x 27.6	50589	66.2	200.0	43886

K 470 interior fittings



Cover pouch

- Durable cover pouch made from black synthetic fibers for self-installation.
- Ideal for tablet PCs, cables, small parts or documents.
- Combines protection for parts with order in the case.
- The pouch can be removed at any time.

SKU	Designation	Dimensions L x W x D (approx. in)	Fits cases with min. internal dimensions (in)
41820	Cover pouch, large	16.5 × 10.2 × 1.6	20.5 × 12.6
41821	Cover pouch, small	10.2 × 5.9 × 1.6	11.0 × 8.7



Attaché insert

- The practical folder for documents and work devices, made from hard-wearing fibers, self-installation.
- Easy to install, self-adhesive.

SKU	Dimensions L x W x D (approx. in)	Fits cases with min. internal dimensions (in)
40626	16.9 × 11.4 × 0.8	20.5 × 12.6



Self-adhesive tool bag

- Removable, comfortable tool bag made from durable fibers.
- Easy to install, no need to drill into adapter plate.
- Also suitable for cases with IP 65 and IP 67 protection.

SKU	Dimensions L x W x D (approx. in)	Fits cases with min. internal dimensions (in)
40630	16.9 × 11.4 × 2.4	20.5 × 12.6



Adjustable aluminum divider wall set

- Includes a divider wall with two spacing bars.
- Stay more organized with self-adhesive plastic spacing bars.
- No tools needed to adjust position of aluminum divider wall.

SKU	Dimensions W x D (approx. in)	Suitable for
40864	13.6 × 8.5	40568
40865	13.6 × 12.0	40678, 40564
40866	17.6 × 13.6	40567



Removable pouch with crosswise dividers

- Sturdy, water-repellant polyester inner pouch.
- Can be completely sealed with wraparound zipper.
- Easy to load and unload through side reinforcement/bracing.
- Removable, equipped with sturdy handles.
- Equipped with cross-dividers that can be arranged as needed using Velcro.



SKU	Suitable for Clear Internal Dimensions L x W x H (approx. in)	Quantity of crosswise dividers	Suitable for
41823	20.5 × 12.6 × 12.2	4	40678
41829	20.5 × 12.6 × 15.0	4	40564
41830	28.3 × 20.5 × 15.0	6	40565
41831	28.3 × 20.5 × 22.8	6	40566

K 470 interior fittings – custom foam inserts – high-tech design

Using a wide selection of materials, ZARGES tech center in Charlotte manufactures tailor-made cushion inserts that provide the best protection and functionality for the goods you are transporting. You provide us with photos, drawings, CAD files or original parts and our engineers will develop the perfect completely customized solution for you.

Various colors are available, as well as antistatic, dissipative and flame-retardant versions.

Among the many benefits that this first-class foam material provides is the ability to calculate in advance the protective effects of the complete packaging according to the military specifications to be used.

Based on weight, area, drop height and sensitivity (G value), we will develop a package with the best custom padding for you. The result is minimum raw materials used at maximum protection.

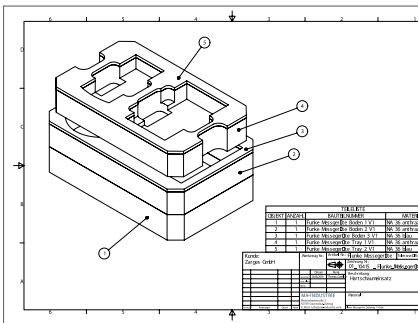

Custom design



3D data simplifies project work



Custom foam insert



Tailor-made colored foam with label



Removable inserts allow quick access at all levels



Delivered empty

Foam blocks

- Pre-punched soft foam inserts made of open-celled PU foam.
- The quick and easy solution for individual items or small series.
- Easily shaped without tools.
- Two different panel thicknesses included: 1.18 inch for studded foam cover insert and 0.39 inch for bottom foam.
- Self-adhesive studded foam for cover.

SKU	Suitable for Clear Internal Dimensions L x W x H (approx. in)	Suitable for
40735	20.5 x 12.6 x 8.7	40810, 40568
43854	20.5 x 12.6 x 15.0	40678, 40564
40736	28.3 x 20.5 x 8.7	40849
43856	28.3 x 20.5 x 15.0	40565

K 470 transport and mobility accessories



Lifting loops made from synthetic fiber

- Load capacity up to 440.8 lbs per case.
 - Light weight.
 - No clasping noise.
 - Each set includes four pieces.
 - Can also be used in combination with hazardous goods approval.
- SKU 40745**



Lifting loops made from stainless steel wire cable

- Easy to clean and decontaminate.
 - Good resistance to UV rays and chemicals.
 - Each set includes four pieces.
 - Can also be used in combination with hazardous goods approval.
- SKU 40746**



Clip-on casters

- Mobility for all cases with internal dimensions $\geq 21.65 \times 13.78$ inch.
 - Can be installed without tools.
 - Solid rubber, $\varnothing 3.94$ inch, swivel casters equipped with wheel stopper.
 - Up to 220.4 lbs capacity on four wheels.
- SKU 40741** **Two fixed casters**
SKU 40742 **Two swivel casters**



W150 dolly trolley

- Aluminum chassis, low version.
- Running gear: two swivel and two fixed casters, $\varnothing 4.9"$, 1.6" wide, easy running, mounted on roller bearings.
- Load capacity 330 lbs.



Pallet

- The case can also be provided on a pallet base, upon request.
- Wood, plastic or aluminum pallets.



Anchor cable

- Prevents removal of closed K 470 from being removed.
- The extra-strong stainless steel cable can only be removed when the lid is open.
- Length 47.24 inch, one cable end equipped with loop; fits all K 470.

SKU	Fits external dimensions L x W, (approx. inch)
40607	23.62 x 15.75 and 22.83 x 14.96
40608	31.50 x 23.62 and 29.92 x 22.83



Custom designs available. Contact us for more information.

SKU	Installation
375891	through ZARGES
41838	self-installation

Comfort fasteners



With installed spring anti-opening feature



For shackle locks with shackle thickness up to 0,24 inch.



Armored hasps for shackle locks up to 0.31 inch.

SKU	Description	Usage
40832	Lock set	only keyed alike in set, suitable for all cases supplied with lock
40833	Lock set	entire series keyed alike, suitable for all cases supplied with lock
40834	Spring anti-opening feature	all K 470 cases
46789	TSA shackle lock	all K 470 cases
46989	Shackle lock	all K 470 cases

ZARGES hazardous goods packaging meets the most exacting requirements

Legislators have specified strict safety regulations for the packaging and transport of hazardous goods. Hazardous goods can only be transported in packages that meet

these criteria and are approved by the respective authorities. ZARGES has decades of experience with UN-approved aluminum packaging.

CLIENT + ZARGES

Consultation and package design (inner and outer package)

PROBLEM SOLUTION AVAILABLE?

YES

- » Solution within existing approval
- » Large selection of existing UN approvals

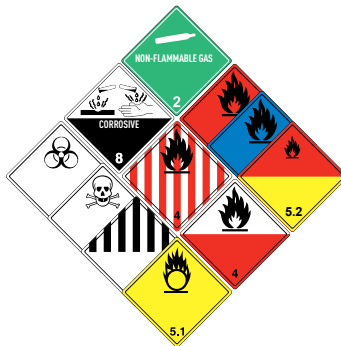

NO

- » Develop a custom solution
- » Designed, constructed and tested by ZARGES
- » Request approval



ZARGES is an authorized testing facility and is able to conduct hazardous goods packaging inspections and request design approval.



BAM certification

The ZARGES product range

The wide range of standard ZARGES products usually provides a number of solutions that meet the highest of requirements. In addition to the K 470, the K 475 series, BY cases, K 410 Alu Case, K 473, collapsible cases and many custom cases have hazardous goods approval.



Mitraset® Classic, also available with hazardous goods approval



Water-vapor-resistant K 475



K 470 with zipper storage bag



Rocket pods

K 470 Plus hood case



Upper section is easily removed



Devices in the lower section can be operated after the upper section is removed

With the K 470 Plus, ZARGES is pursuing an innovative packaging design: a two-part transport system, consisting of an upper and lower section. This means that elements of varying heights can be combined with one another, creating a number of useful variations.

These cases are designed to transport and store heavy devices. The K 470 Plus is suitable for devices operated directly in the case, such as flash units, printers, measurement devices, etc.

- The device does not need to be lifted out of the case.
- Access case contents via the lid.
- If the device needs to be lifted out from the crate, the transport system reduces the lifted out of the crate by allowing for the upper section to be removed.

Many K 470 accessories can be used effectively with the K 470 Plus.

K 470 Plus outer dimensions: 23.62 x 15.75 inches

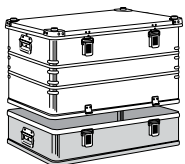

Description	SKU	Clear Internal Dimensions L x W x H (approx. in)	Overall Dimensions L x W x H (approx. in)	Volume (approx. cu in)	Weight (approx. lbs)
Lower section	40500	20.5 x 12.6 x 5.9	23.6 x 15.7 x 7.1	1770	5.7
Upper section	40501	20.5 x 12.6 x 8.7	23.6 x 15.7 x 9.8	2563	8.8
Total height with lower section 5.91 inch : 14.57 inch					
Upper section	40502	20.5 x 12.6 x 15.0	23.6 x 15.7 x 16.1	4454	10.4
Total height with lower section 5.91 inch : 20.87 inch					

K 470 Plus outer dimensions: 31.50 x 23.62 inches

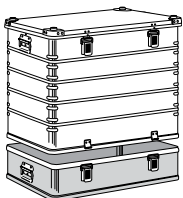

Description	SKU	Clear Internal Dimensions L x W x H (approx. in)	Overall Dimensions L x W x H (approx. in)	Volume (approx. cu in)	Weight (approx. lbs)
Lower section	40503	28.3 x 20.5 x 5.9	31.5 x 23.6 x 7.1	3783	10.6
Lower section	40504	28.3 x 20.5 x 8.7	31.5 x 23.6 x 9.8	5553	12.1
Upper section	40505	28.3 x 20.5 x 15.0	31.5 x 23.6 x 16.1		19.0
Total height 20.87 or 23.62 inch					
Upper section	40506	28.3 x 20.5 x 22.8	31.5 x 23.6 x 24.0	14645	23.1
Total height 28.74 or 31.50 inch					

Paint and labeling

Paint

All RAL colors are available in standard paint finishes:

- Labeling per TLA-0003 RAL 6031 F9 or RAL 6031 HR, pursuant to ZARGES standards.
- Labeling per TLA-0033 RAL 6031 F9 or RAL 6031 HR, standard.
- Coating per various military standards: Def Stan, MIL-STD etc.



Labeling

ZARGES offers custom labels:

- Screen printing, single or multiple colors.
- Self-adhesive film, non-removable upon request.
- Adhesive letters.
- Installation of name plates.



Adhesive label for delivery notes

Secure spot for shipping labels. Self-adhesive. Easy to clean.

SKU	Dimensions L x W (approx. in)
343904	11.0 x 11.0



Labeling

- Embossed plates: placed on cases with embossing in DIN typeface, uppercase letters, 0.79 inch font heights, single and multiple lines.
- Embossing: DIN typeface, uppercase letters, 0.79 inch font heights, single and multiple lines.
- Label edges: in various sizes per DIN or custom sizes.



ZARGES K 470 IP 65 and IP 67 – protection against water and dust

Do you need ultimate protection for transporting your equipment? Are you concerned about dust, water or pressure differences? ZARGES provides the uncompromising solution.

ZARGES K 470 IP 65 – now dustproof and water-jet-proof – according to DIN 60529.

- Large selection of standard sizes.
- Also available with hazardous goods approval.
- Protection tested and certified by TÜV SÜD.

ZARGES K 470 IP 67 – optimal protection when submersed in water.

High-quality custom case, protection against temporary submersion per IP 67 protection.

- Patented ZARGES fastener system.
- Extra large pressure equalization valve.
- Leak-tightness verified with TÜV SÜD certificate.

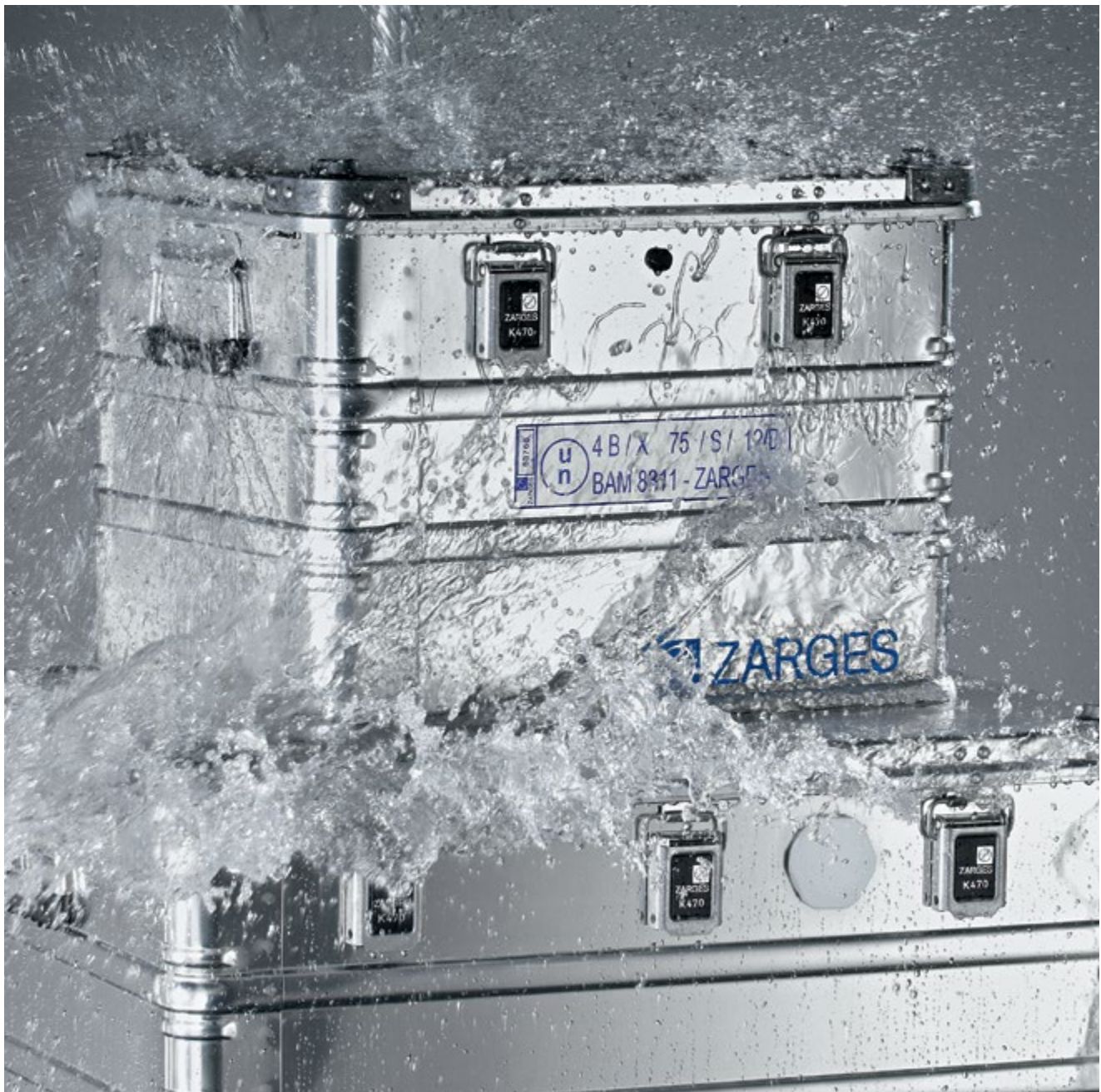

K 470 IP 65 and IP 67



ZARGES has improved the long-proven and legendary K 470 Universal case once again:

- Standard K 470 cases are equipped with dependable dust and splash water protection. The new models with IP 65 or IP 67 protection show their strength wherever extra leak-tightness and increased protection against dust, moisture, water jets or even occasional water submersion are required.
- To allow the cover to open reliably after the air pressure changes, the K 470 IP 65 and IP 67 are equipped with an automatic pressure equalization device. A Gore™ membrane guarantees permanent equalization of pressure differences and is impervious to dust, salts, water and other liquids. The automatic valve helps prevent user error.
- Both the K 470 IP 65 and K 470 IP 67 series have been subjected to rigorous testing by TÜV SÜD, successfully earning certification.
- With only a few exceptions, the optional seal per IP 65 protection is available for all K 470 cases. Moreover, the new equipment can be combined with additional hazardous goods approval.
- The K 470 IP 67 series includes four sizes, custom designs available by request.



Water-jet protection per IP 65 standard



IP 67 protection via patented ZARGES fastener system

ZARGES K 470 IP 65

SKU	Clear Internal Dimensions L x W x H (approx. in)	Overall Dimensions L x W x H (approx. in)	Volume (approx. cu in)	Weight (approx. lbs)
366206	20.5 × 12.6 × 15.0	23.6 × 15.7 × 16.1	4271	11.7
366217	28.3 × 20.5 × 15.0	31.5 × 23.6 × 16.1	9580	22.0
366218	28.3 × 20.5 × 22.8	31.5 × 23.6 × 24.0	14584	26.5

ZARGES K 470 IP 67

SKU	Clear Internal Dimensions L x W x H (approx. in)	Overall Dimensions L x W x H (approx. in)	Volume (approx. cu in)	Weight (approx. lbs)
380366	20.5 × 12.6 × 15.0	23.6 × 15.7 × 16.1	4271	11.7
379083	28.3 × 20.5 × 15.0	31.5 × 23.6 × 16.1	9580	22.0
380378	28.3 × 20.5 × 22.8	31.5 × 23.6 × 24.0	14584	26.5
379725	34.3 × 24.0 × 17.7	37.4 × 27.2 × 18.9	15804	29.5

SKU	Optional IP 65 seal for K 470
926002	40835, 40677, 40810, 40568, 40678, 40564, 40849, 40859, 40836, 40837, 40839, 40841, 40842, 40843, 40565
926003	40566, 40580, 40844, 40845, 40846, 40567, 40847

K 410 aluminum case



Resilient, tightly sealed ZARGES K 410 aluminum cases are the perfect transportation and packaging tool for tough jobs. Ideal for securely packaging sensitive goods, the anodized aluminum design is also suitable for device housings and for installing electronics.

Sturdy, lockable, dustproof, water-jet-proof and equipped with ergonomic handles, exemplary functionality, long service life and timeless design.

- Aluminum case, anodized, versatile.
- Noncorrosive.
- Smooth surfaces.
- Corner reinforcement with corner pieces.
- Comfortable handling.
- Turnbuckles with spring anti-opening feature.
- Hinged cover with circumferential seal, thus dustproof and splashproof.
- Clearance dimensions approx. 0.79 inch lower than internal dimensions (length and width).



Custom aluminum case



Circumferential seal

Optional UN hazardous goods certification for all sizes.

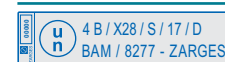

no.	SKU	Clear Internal Dimensions* (approx. in)	Overall Dimensions L × W × H (approx. in)	Volume (approx. cu.in)	Weight (approx. lbs)
1	40765	13.4 × 11.0 × 5.5	14.6 × 13.0 × 5.7	915	4.0
2	40763	17.7 × 13.0 × 4.7	18.9 × 15.0 × 4.9	1220	4.9
3	40764	20.1 × 12.2 × 5.5	21.3 × 14.2 × 5.7	1526	5.5
4	40766	17.7 × 13.0 × 7.0	18.9 × 15.0 × 6.9	1709	5.9

Important: Clearance dimensions approx. 20 mm lower than internal dimensions (length and width). Custom sizes by request.

K 411 Attaché case



The legendary quality of ZARGES is now available in an attaché case! The ZARGES K 411 Attaché case combines elegant design with rugged and extreme durability - for the perfect look while on the move.

- Elegant and prestigious appearance, exclusive ZARGES design.
- Scratch-resistant surfaces made from high-quality anodized aluminum profiles and innovative plastic shells keep the case looking like new.
- Long service life thanks to durable design and manageable weight.
- Plastic components protect sensitive surfaces from scratches.
- Easy-to-use locks with integrated burst-protection and combination lock.
- Resistant to dust and water thanks to all-around seal.

no.	SKU empty	SKU with	Clear Internal Dimensions* (approx. in)	Overall Dimensions L x W x H (approx. in)	Volume (approx. cu.in)	Weight (approx. lbs)
1	41713	41718	13.9 × 11.5 × 5.5	14.8 × 13.6 × 6.3	921	4.9
2	41714	41719	16.2 × 12.3 × 5.1	17.1 × 14.4 × 5.9	1068	5.4
3	41715	41720	18.2 × 13.5 × 5.1	19.1 × 15.9 × 5.9	1306	6.2
4	41716	41721	20.6 × 12.7 × 5.5	21.5 × 15.2 × 6.3	1495	6.6
5	41717	41722	25.4 × 17.6 × 7.5	26.2 × 20.1 × 8.3	3429	10.3

Internal height dimension combines upper and lower case heights.



Case with lining – for a professional look

Standard version has distinguished black interior design with functional cover insert for small parts, documents and business cards.

SKUs 41718 - 41722



The instrument case

For measurement technology, medical technology and many other special applications. High-quality technical devices receive optimum, custom-fit protection from this ZARGES case during transport.

More information on page 47.

Testing and certification

ZARGES products have been used successfully for decades by armed forces around the world. Moreover, the products are also continuously subjected to rigorous testing by inde-

pendent testing institutes, passing them with flying colors. These tests are supplemented by running tests at the modern ZARGES testing facility.

Test	Test description
Environmental tightness	
IP65 – dustproof and splashproof per DIN EN 60529:2014-09	Water jets Test duration 3 min/side without lower side v/min 12.5 l/min
MIL-STD-810 G – Method 506.5 Rain – Procedure I – Rain and Blowing Rain	Wind speed 18 m/s Rain intensity 100 mm/h Test duration at least 30 min per side
MIL-STD-810 G – Method 510.5 Sand and Dust – Procedure I – Blowing dust	Wind speed 8.9 m/s Dust-tightness: 10.6 ± 7 g/m ³ Particle size ≤ 149 µm ≤ Test duration 2 × 6 h
IP65 – dustproof and immersion-proof per DIN EN 60529:2014-09	Submerged approx. 1 m Test duration 30 min
Material/corrosion resistance	
MIL-STD-810 G – Method 509.5 Salt fog test	Test duration 96 hours Temperature 35° C
Resistant to fungus per MIL-STD 810 F Method 508.4 – Fungus	Test duration 28 days
Temperature resistance	
High temperature test Test 501.2 per MIL-STD-810 D-3, Procedure I A2.	Test duration 24 hours Temperature of 71 °C
Low temperature test Test 502.2 per MIL-STD-810 D-4, Procedure I C2.	Test duration 24 hours Temperature of -51 °C
Hazardous goods approval	
ZARGES has decades of experience in the area of containing hazardous goods and can point to numerous existing approvals.	Packaging group I, drop height 1.80 m. Stack pressure test. Packaging group II, drop height 1.20 m. Stack pressure test. Class 6.2, drop height 9.0 m, puncture test, stack pressure test
Mechanical strength	
Handle strength up to 750 N (approx. 75 kg)	from VG 95 447:
IATA ATA Spec 300, Category I (100 revolutions)	Drop strength: gross weight 23 kg, drop height 76 or 92 cm, number: 280 drop tests Leak-tightness: 100 l/h Vibration test: Duration 2 hours
TÜV certificate, lifting device	tested per DIN EN 1492-1:2000 (Art. 61892 A), DIN EN 1677-1:2000 (Art. 356050 C), PPP 53297:2007 (Art. 357967 B)
Vibration dampening	
Vibration dampening	see page 11 for Mitraset®, individual examples of use
HF shielding	
	see page 22 for Mitraset®, individual examples of use
NATO Stock Numbers	
	For decades, ZARGES has been an established supplier to many armed forces and possesses a great number of stock numbers.
Environmental protection	
Reach	ZARGES continuously verifies compliance with European Directive (EC) No. 1907/2006
RoHS	cannot be used for CASES.



Testing institute	available for series
IABG, TÜV SÜD, ZARGES	Mitraset® Classic, Mitraset® Racklite, Mitraset® Racklite Basic, K 470 IP 65, K 475 as well as other custom series per client specification
IABG	Mitraset® Classic, K 475, K 470 IP 65
IABG	K 470 IP 65
TÜV SÜD, ZARGES	K 470 IP 67, K 475
IABG	Mitraset® Classic, Mitraset® Racklite, Mitraset® Racklite Basic, K 470, K 475, K 473 as well as other series per client specification
IABG	Mitraset® Classic, Mitraset® Racklite, Mitraset® Racklite Basic, K 470, K 475, K 473 as well as other series per client specification
ZARGES	Mitraset® Classic
ZARGES	Mitraset® Classic
BAM, ZARGES	K 470, K 475, K 473, K 410 aluminum case as well as special series per client specifications
BAM, ZARGES	Mitraset®, Retour® collapsible cases as well as other custom cases per client specifications
BAM, ZARGES	K 470, K 475
BAAIN Bw	This grip is also used for K 470, K 475, K 473 and various special cases
Dayton T. Brown	K 470 (40564)
TÜV Süd	K 470
Serco; Siemens; various individual measurement reports	Mitraset®
Serco; Siemens; various individual measurement reports	Mitraset®, K 475
Stock numbers may be issued by the respective authorities of each NATO member.	Mitraset®, K 475, K 470, Y case, various custom cases
ZARGES	compliant



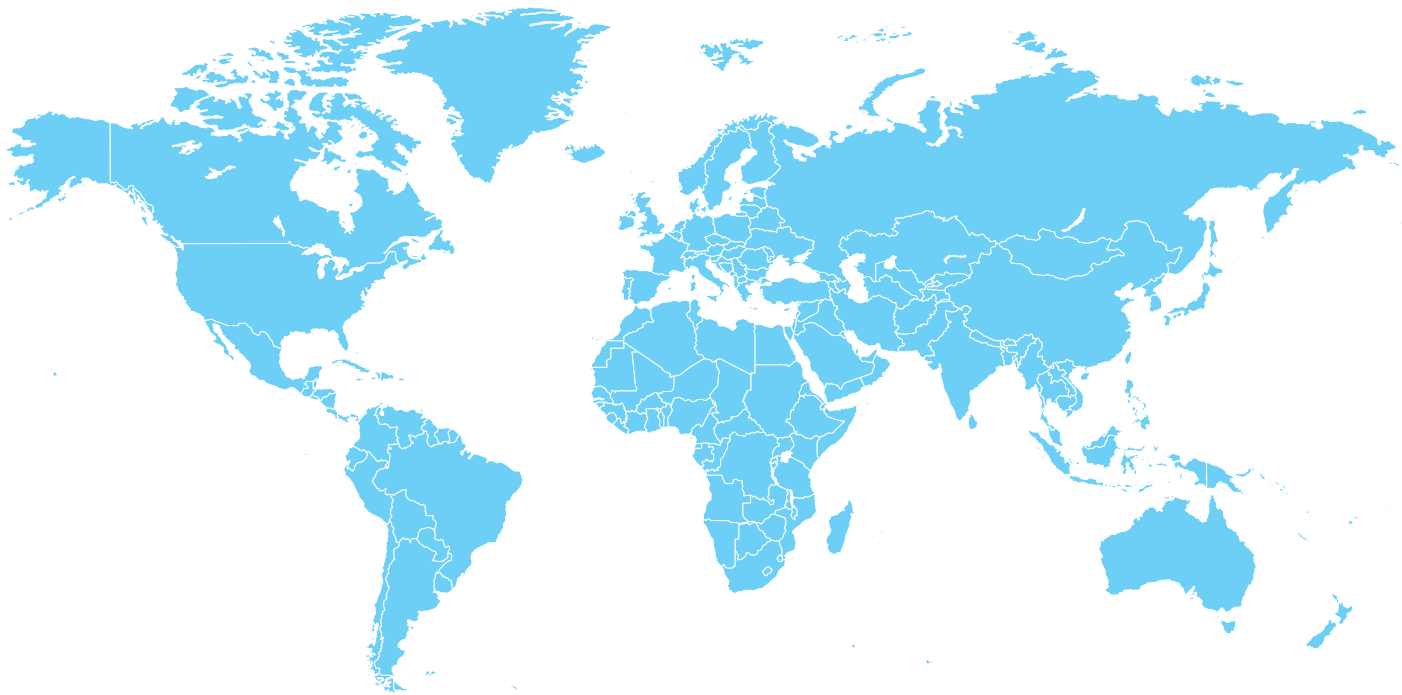

ZARGES subsidiaries

Austria

ZARGES GmbH · Hallergasse 37 · 1110 Wien
+43 1 749 15 53 0 · office@zarges.at · www.zarges.at

Czech Republic

ZARGES CZ, s.r.o. · Hnevkovského 87 · 61700 Brno
+420 5 432 34 72 7 · obchod@zarges.cz · www.zarges.cz

Denmark

ZARGES Danmark · Røholmsvej 15 · 2620 Albertslund
+45 43 64 02 00 · stiger@zarges.dk · www.zarges.dk

France

ZARGAL S.A.R.L · ZA Activeum – 4 rue Georges Guynemer ·
67129 Molsheim Cedex
+33 3 88 50 82 07 · zargal@zargal.fr · www.zargal.fr

Germany

ZARGES GmbH · Zargesstraße 7 · 82362 Weilheim
+49 881 687 131 · special.systems@zarges.de ·
www.zarges.de

Great Britain

ZARGES U. K. Ltd. · Holdom Avenue – Saxon Park Industrial
Estate Bletchley 8 · MK1 1QU Milton Keynes · +44 1908 64 11 18 ·
sales@zargesuk.co.uk · www.zargesuk.co.uk

Hungary

ZARGES Kft · Jókai u. 26 · 1066 Budapest
+36 1 332 1190 · info@zarges.hu · www.zarges.hu

Netherlands, Belgium, Luxemburg

ZARGES B.V. · Knippersven 7 · 5056 DE Tilburg
+31 135231130 · info@zarges.nl · www.zarges.nl

Poland

ZARGES Polska Sp. z o.o. · ul. Gen. W. Andersa 10 a ·
41200 Sosnowiec
+48 32 292 53 70 · zarges@zarges.com.pl · www.zarges.com.pl

Sweden

ZARGES AB · Oestra Bangatan 14 · 19560 Arlandastad
+46 8 59122000 · stegar@zarges.se · www.zarges.se

Switzerland, Liechtenstein

ZARGES GmbH · Oberdorf 1 · 8222 Beringen
+41 52 682 0600 · schweiz@zarges.ch · www.zarges.ch

USA, Canada

ZARGES Inc. · 1440 Center Park Drive · Charlotte, NC 28217
+1 704 357 6285 · sales@zargesusa.com
www.zargesusa.com

**For information about further local ZARGES partners
in many countries all over the world please contact:**

 international-sales@zarges.de
www.zarges.com/defence