

FRONTIER METAL

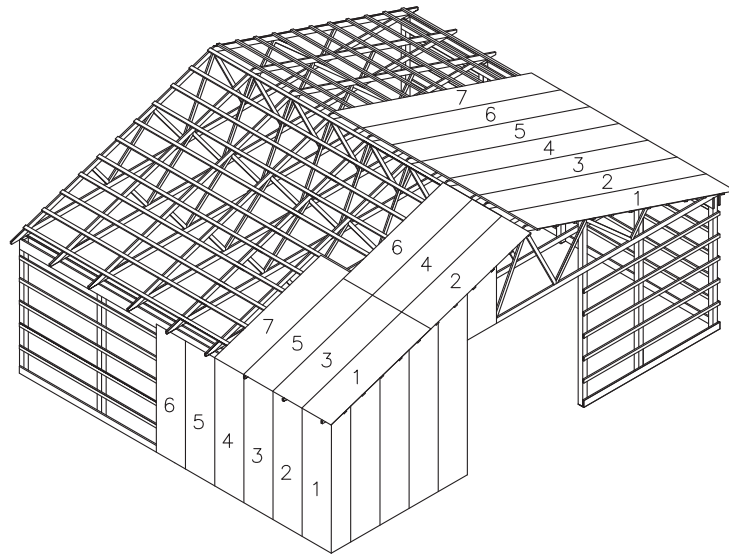

Metal Panel Installation & Trim Guide

Storage

Store the Metal Panels in a dry place. The panels should be stored outside only when it is absolutely necessary and, even then, only for short periods of time. Canvas or waterproof paper may be used to cover the panels only if there is adequate ventilation. Plastic tarps should never be used because they may trap moisture causing sweating and condensation. Panels that are installed immediately will perform correctly even if they were wet in the

bundle. If panels get wet and are not ready to be installed immediately, they need to be separated and completely dried. As with all bundled and stacked roof and siding panels, water or any liquid will siphon (capillary action) from ends and sides of stacked panels.

If these precautions are not taken and moisture is trapped in the panel, superficial staining or paint peeling may occur. When moisture remains

in the bundle for a considerable time, wet storage stains and paint defects may occur, reducing the beauty and effective life of the panel.

Failure to comply with all the above recommended procedures voids all warranties and relieves Frontier Metal of any responsibilities for the resulting damage to, or deterioration of, the Metal panels.

Handling

Use extreme caution when handling the Metal Panels. Improper handling may cause bodily injury or material damage. A forklift can dent or puncture the underside of the Metal Panel. We recommend that a spreader device is used on the forklift for bundles over 20 feet in length to avoid bending the Metal Panels.

Care should also be exercised to protect the finish when lifting individual panels from the stack or bundle. Dragging of individual sheets from the bundle can scratch the surface and reduce the paint performance. Though the paint finish of the Metal Panels is tough enough to withstand usual weather conditions, it can be scratched and

abraded if care is not taken. The panel edges must be protected at all times during the unloading and handling process to insure proper fitting and proper looking lap joints on the finished installation.

Purlin Caution

Green or wet oak purlins are not recommended due to an acid in the oak which can cause the metal to rust prematurely. Also, on a reroof job where a slate roof has been used previously, metal is known to rust prematurely due to residue on the purlins from the slate. Treated purlins are not recommended either. If the above mentioned purlins are to be used, a barrier like Solex

reflective insulation, FT Platinum, or Peel & Stick should be used between the purlins and metal sheeting.

Caution must be taken to inspect purlins for knots and rotten or soft spots. Purlins must be solid enough for fasteners to hold properly and to withstand the applicator's weight. Persons working on the purlins can fall through if not careful.

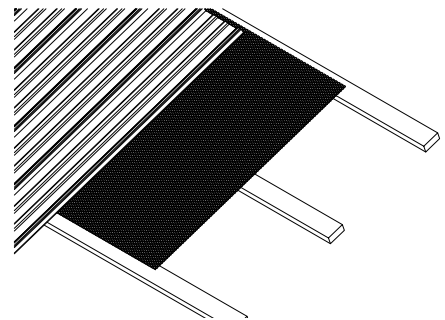

Fig. 1

Cutting & Trimming

There will always be a certain amount of cutting and trimming necessary on the job site. Whether cutting with the rib or against it, use an offset hand snips or a Turbo Shear. For even better results, cutting may also be accomplished with a portable shear profiled to conform to the Metal Panels for perfect across-the-profile cutting.

Also care should be taken to brush off all particles after installation to further reduce the possibility of rust marks and bleeding on the panel after it is installed.

ATTENTION: Failure to comply with the recommended procedures relieves Frontier Metal of all responsibility for any resulting damage to, or deterioration of, the paint finish and immediately voids the paint warranty.

ATTENTION: Using a cutting torch, steel cutting blade, abrasive blade or a Carborundum Blade with a saw is not recommended and voids the warranty.

CAUTION: Be extra careful when working with roofing and siding. Safety glasses and other safety equipment is recommended and should be worn by the worker.

Panel Installation

Begin laying the roofing panels on the end of the building away from the prevailing wind so the side lap seams will face away from the prevailing wind-driven rain. This provides extra security against water penetration.

Since the first panel determines the alignment of all remaining panels on the roof, extreme care should be taken to accurately square the first sheet. The overlapping rib edge should be flush with the edge of the roof, and the panel should overhang the eaves a minimum of two inches to provide proper drainage. The side rib with the drain channel should face the direction in which the sheets are being laid down (Figure 2). When the panel is positioned, it should be fastened through the first rib, top and bottom. The Metal Panel should be attached completely before starting the next panel.

A tip for assuring straight alignment for successive rows of panels is to stretch and snap a chalk line on the bottom purling from one gable end to the other. Then lay the next sheet and measure from the end of the sheet to the chalk line. This will help keep bottom edge straight.

If roof requires more than one horizontal row of panels, align panel #1 with your vertical-edge chalk line, and temporarily fasten the panel at two points, not at the ends, but along the main middle ribs. Overlap panel #2 above panel #1. Align both panels with the chalk line and permanently fasten. Install panel #3 next to panel #1 overlapping the Metal Panel as shown in Figure 3. Install panel #4 above panel #3.

It is important to check alignment from ridge to eaves on every sheet. Permanently fasten when the panels are in line.

Be careful to properly overlap the panels as seen in figure 3. Improper overlap installation will cause leaks and may void the panel warranty.

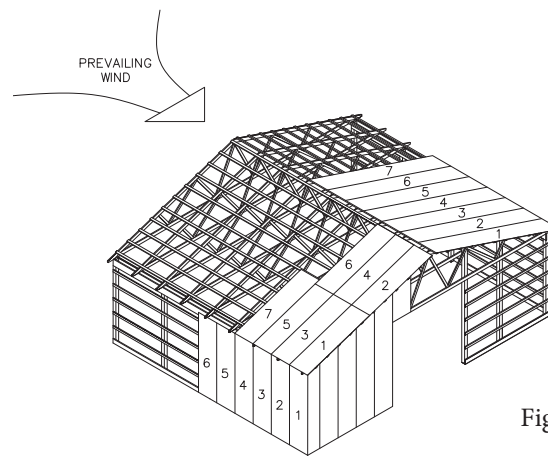

Fig. 2

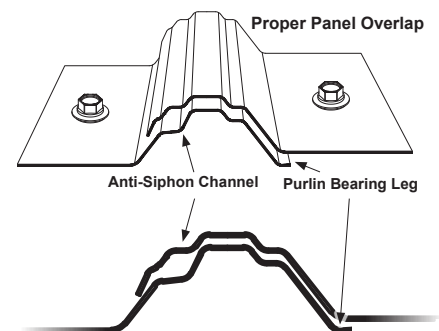

Fig. 3

Panel Profile

Approximately 3/4" high major ribs on 9" centers with two 1" wide minor between each. Overlap has an anti-siphon break for leak-free application above 3:12 pitch.

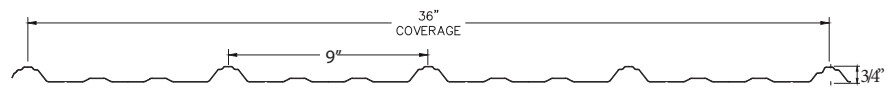

Fig. 4

Fastening

Acceptable fasteners include such items as: Sealtite WoodBinders, Evergrip 304 stainless steel, Bi-Metal or equivalent screws. All screws must have an EPDM sealing washer and should be mechanically galvanized and painted to match the roofing and siding colors. Metal to wood screws with combination metal and EPDM sealing washers should be mechanically driven into the valley or the bottom flat surface immediately adjacent to the major rib on one side or the other for both roofing and siding panels (See Figure 5).

For Purlin Installation

Screw length should allow for penetration of one inch.

For Sheeting Installation

Screw length should allow penetration of the sheeting, but spacing requirements will vary depending upon the thickness, type of sheeting, and uplift requirements.

Millings or filings will occur from installing the screws. Care should be taken to brush off all particles after installation to reduce the possibility of rust marks and bleeding on the panel.

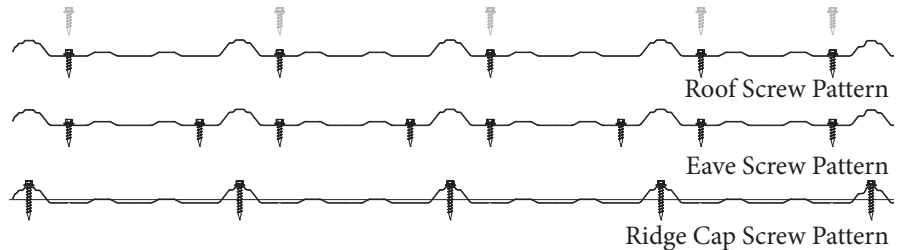
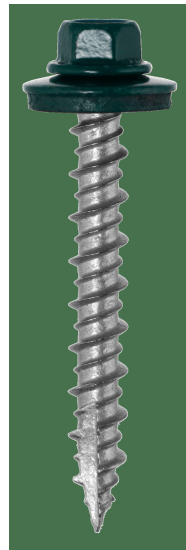
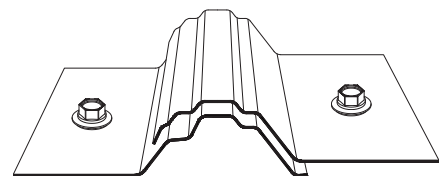

Fig. 5



Stocking the Fastgrip #10 Hi-Lo WoodBinder. They are sharper, drill better, and the cut point is true. The paint stays on when installing and builders prefer Fastgrip's "true" sizing and Hi-Lo threading for better holding power and easy installation.



Drive the screw through the steel so the washer is compressed securely against the metal. **DO NOT OVERDRIVE** the screw, because dimpling will cause the panels to leak. Under-driving can also allow leakage to occur around the screw shaft.

NOTE: For proper application, the use of impact drivers are not recommended for powder coated or any wet painted fastener. Use of an impact driver may void the paint warranty of the panel.

Roof Pitch

Metal roofing requires a certain degree of pitch to ensure proper drainage. Roofing should be applied on roofs with a pitch of at least 2 1/2 inches per foot. To insure weather tightness, a 3/8 inch wide butyl

sealant tape can be used on the overlap. When you need to end lap roof panel sheets, an 8 inch lap is recommended with a roof pitch of 3 inches to 5 inches. Any slope 5 inches or more requires a

7 inch end lap. Panels can be ordered up to 48 foot in length to help reduce end lapping.

Panels Over Shingles

Metal Panels can be installed over existing sheeted roofs (make sure you install a vapor barrier) or directly over shingled roofs. For shingled roofs, place 1x4 or 2x4 purlins on top of shingles. Securely screw the purlins

to the rafters, not the sheathing. Pull the drip edge from underneath the shingle and/or cut flush to the roof sheathing. After purlins are fastened, install a Drip Edge (#60) on top of the purlins running along the eaves to

cover the wood purlins. Then finish the rake with a residential rake or corner trim (#2). Make sure you consult local codes for possible weight limitations with multilayer roofing.

Condensation

Condensation can cause a problem for metal roofing over open purlins especially for residential applications. It is recommended to lay a Solex reflective insulation over the trusses or rafters and then install the purlins on top of the Solex reflective insulation. Tape all joints and staple the reflective insulation to the bottom of the purlins. The insulation will be most effective with at least a 1 inch air space between the insulation and the metal roof sheathing.

Condensation from animal confinement can shorten the life of a metal roof by rusting the metal from the inside out. A Solex reflective insulation will increase the life of metal roof sheet where animals are confined.

If roof purlins are already installed, lay the insulation on top of the purlins. Then fasten the sheathing through the insulation into the purlins. The Solex insulation will greatly reduce the condensation plus reflect radiant heat from the sun, thereby keeping your buildings cooler in the summer and warmer in the winter.

Side-Wall Panels Installation

Siding panels should be installed starting at the corner or edge of building. Do not run siding sheets all the way to the ground. It is important that all siding panels be kept 6 to 18 inches from contacting the soil to minimize sheet corrosion. A RatGuard (#3) is recommended at the bottom edge over the foundation or splash board. If however you use treated lumber or treated skirt board, use a barrier like Peel & Stick to cover the treated board before trims or panels are installed. Evergrip 304 stainless steel Bi-Metal screws are recommended to fasten the panels to treated purlins.

The first siding panel must be plumb to assure straight alignment of the entire row of panels. A level should be used to check if panels are plumb. Temporarily fasten the first Metal panel at the starting edge. Install the second panel next to the first with the Metal Panel overlapping.

Run a string along the purling where fasteners are to be installed. This keeps a straight line to permanently fasten panels.

Metal panel can be installed on sidewalls that have up to 3 foot purlin spacing. When you apply panels to solid sheathing, or old weather boards, you may need to use longer screws to reach into solid wood.

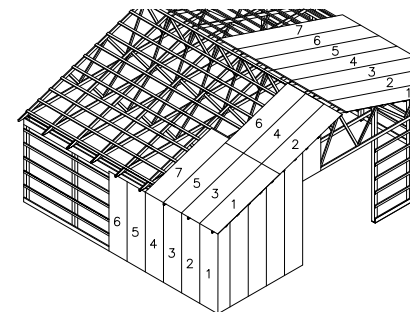
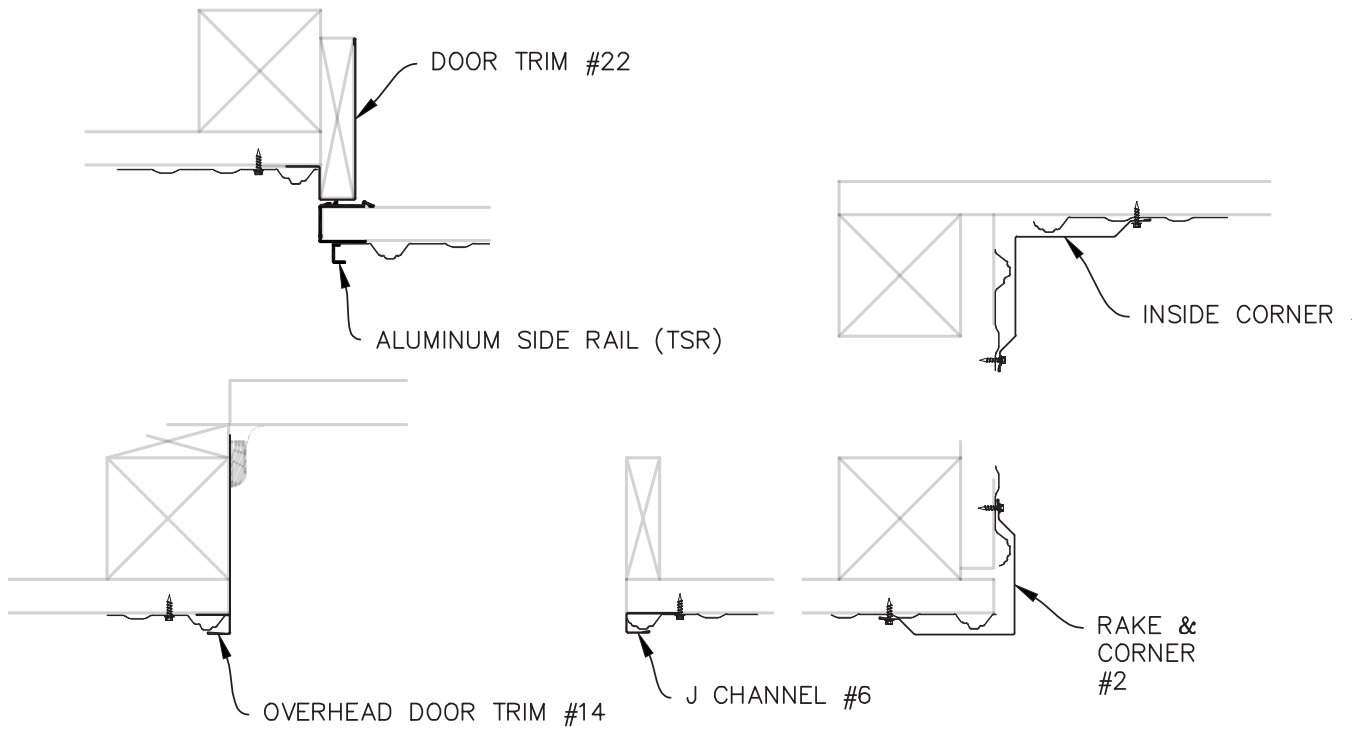

Fig. 6

NOTE: Purlins are also referred to as girts or roof lath. Metal panel roofing & siding is also referred to as roof panels, roof sheathing, tin roofing, corrugated roofing, and other names.

Corners & Door Trim (Top View)



Rakes & Corners Flashing (Side View)

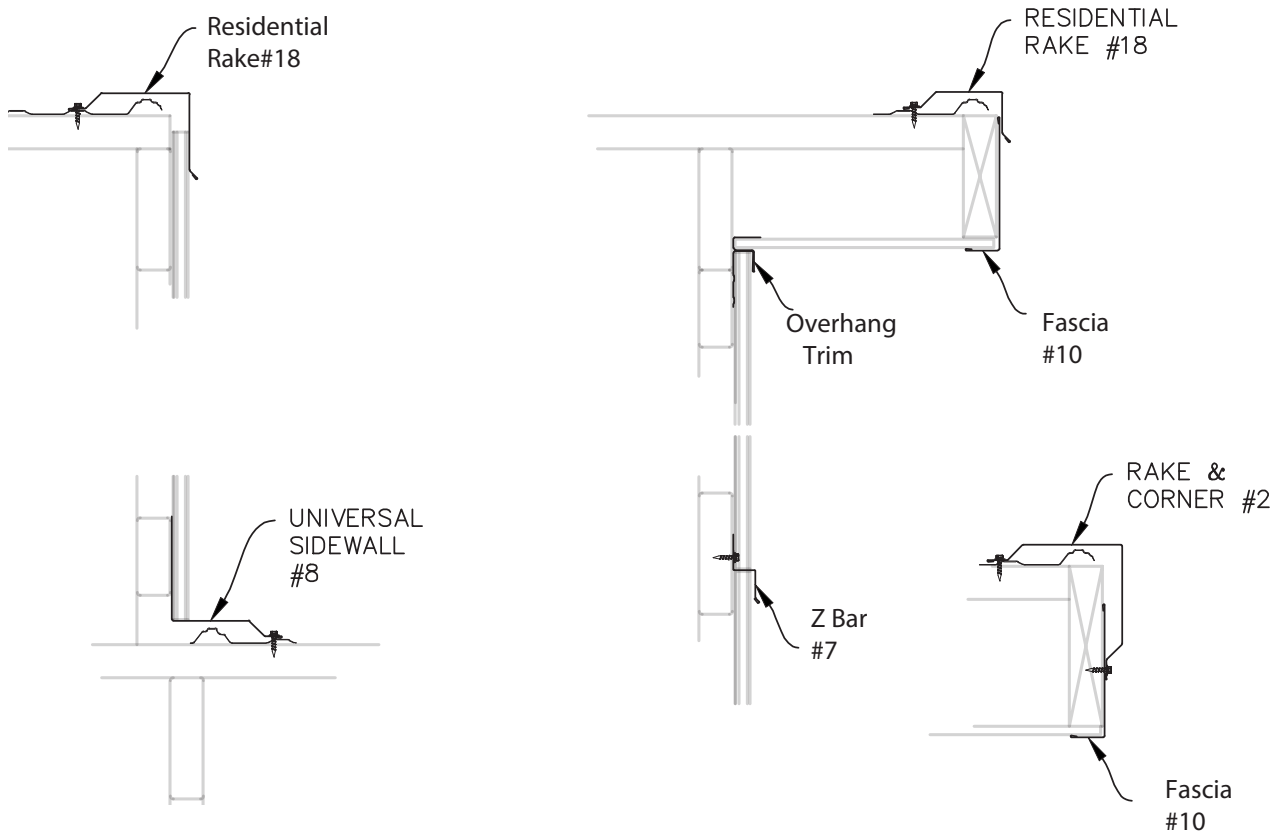

Common Trim Usage

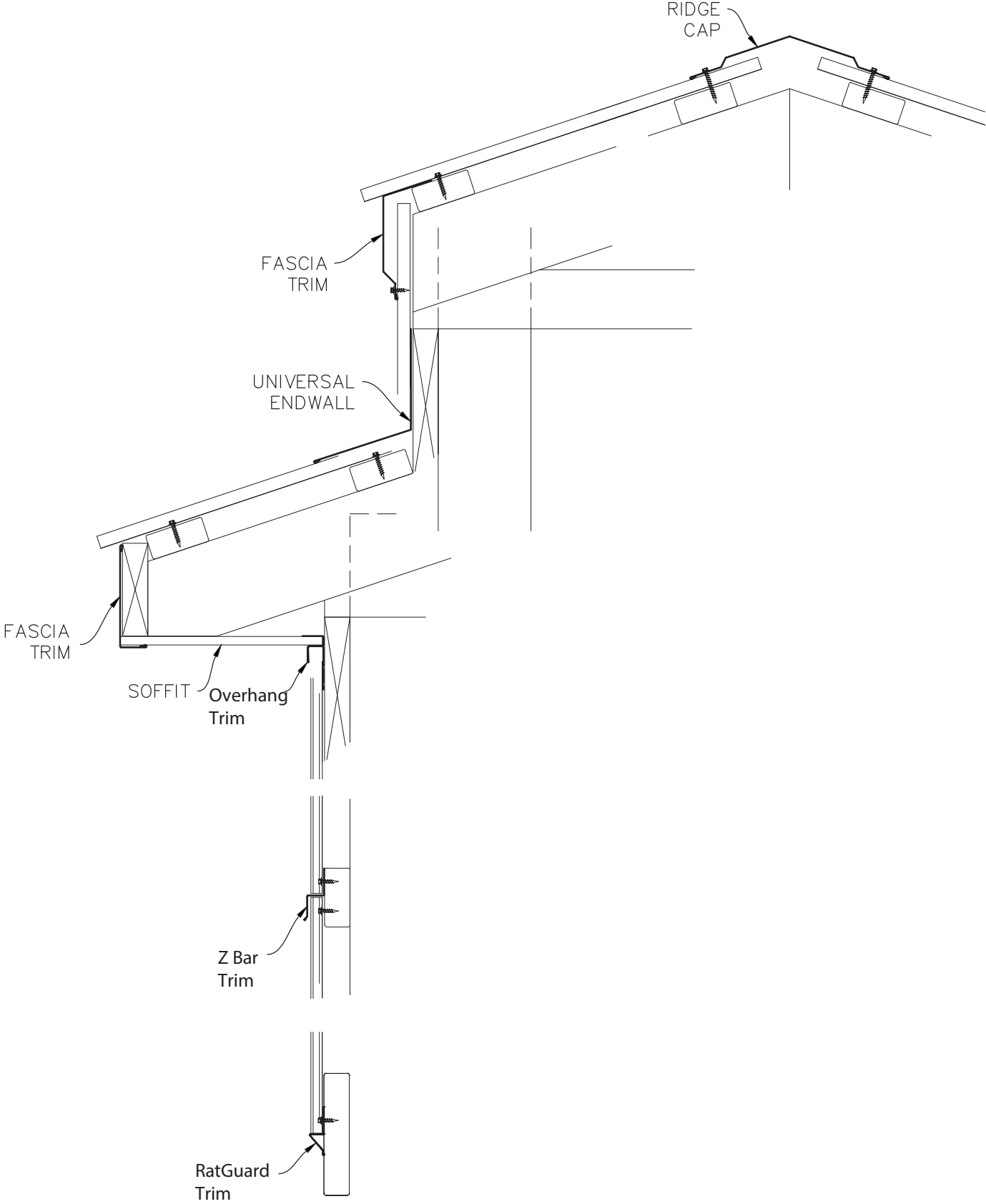

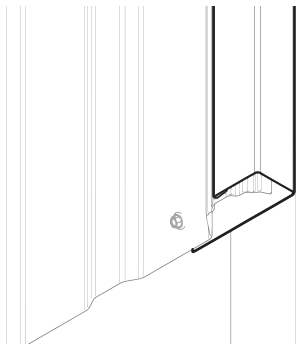

6 J Channel

From walls to triming around windows and doors, the J Channel is one of the most versatile and most used trim pieces.

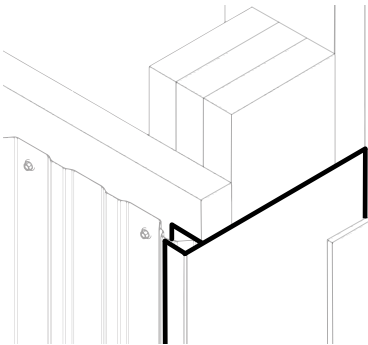

14 Overhead Door (ODcc)

Almost a combination of the 10 Door Post Trim and 6 J Channel, the Overhead Door trim works for the sides and top of an overhead door entrance.

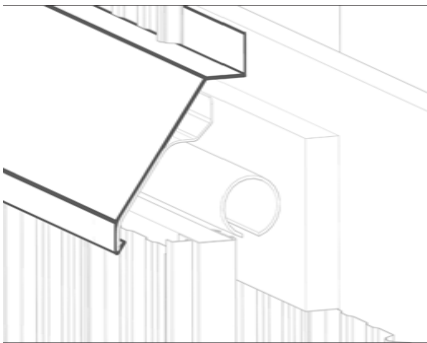

15 Track Cover

Commonly used to cover the tracks of rolling/sliding doors. Get it in the color of your choice.

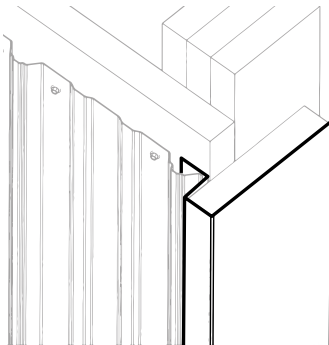

22 Door Post Trim

Most often used to trim a sliding door opening.

Trim drawings might not be pictured in actual scale.
Please reference the Trim Charts for precise trim measurements.

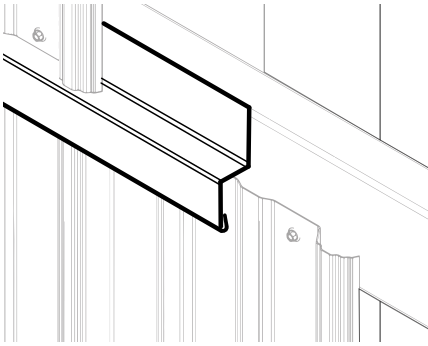

7 Z Bar

Commonly used to provide a straight edge between multi-layers of panels such as when adding a wainscoting or finishing the gable.

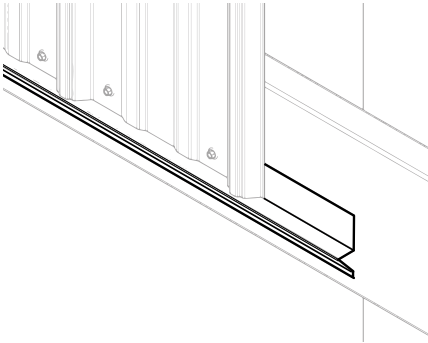

3 RatGuard

Start with a RatGuard for an easy way to perfectly align the entire bottom row of wall panels.

Tip: Use your contrasting trim color to provide a clean horizontal footer appearance.

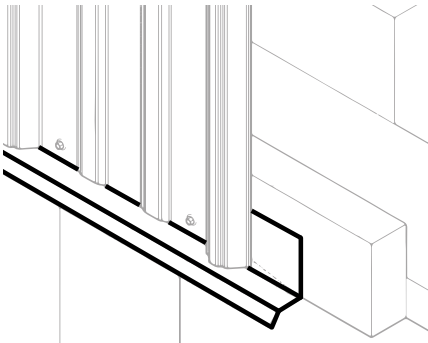

9 Drip Flashing

Commonly used above windows or doors to direct the precipitation away from the panel.

Trim drawings might not be pictured in actual scale.
Please reference the Trim charts for precise trim measurements.

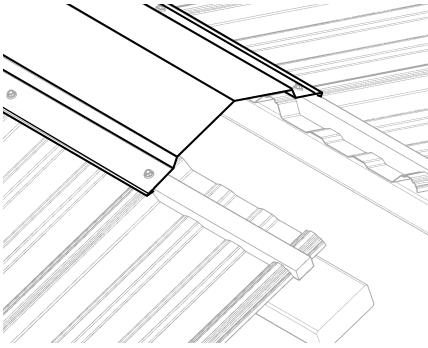

1 Ridge Cap

Finish off your roof with the Ridge Cap to allow the heat to escape the attic space and allow fresh air to infiltrate the building. For best results, use either our Outside Foam Filler Strip, EmSeal, UltraVent Filler Strips, to prevent driving wind from carrying rain and debris under the Universal Ridge Cap.

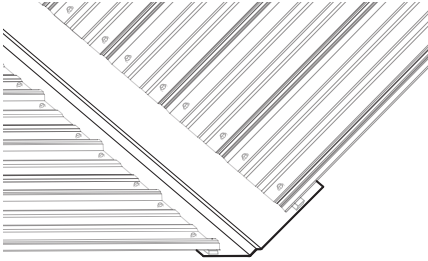

19 Valley Flashing

Wide enough to ensure proper overlap to prevent moisture from seeping up under the two opposing roofing panels. Best practice recommends running EmSeal along the edge of the Valley Flashing to prevent driving winds from carrying rain and debris under the roof panels.

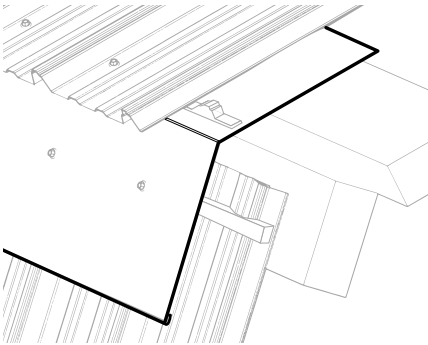

49 Gambrel Trim

The Gambrel trim is the perfect trim for connecting two parts of a roof that have differing pitches. For best results, make sure you extend the top roof panel at least 1" past the edge of the first bend of the Gambrel Trim, and the use of both Inside Foam Filler Strips under the top panel and Outside Foam Filler Strips on top of the bottom panel is recommended.

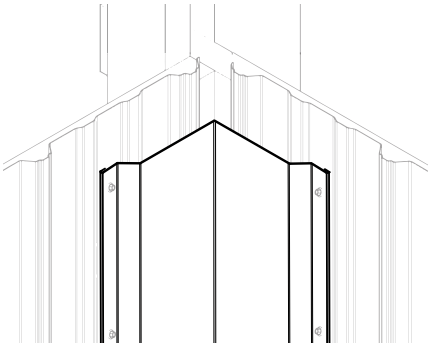

13 Inside Corner

Used for finishing the inside corner of a wall.

Trim drawings might not be pictured in actual scale.
Please reference the Trim charts for precise trim measurements.

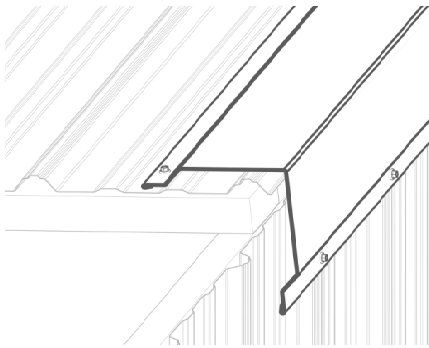

2 Rake & Corner

The Rake & Corner is designed for trimming a sloping roof with the lower level side wall. Can also be used as an outside vertical corner. For best results, use either EmSeal or Sealant Tape to prevent driving wind from carrying rain and debris under the Rake & Corner especially if the roof panel does not end with a major rib.

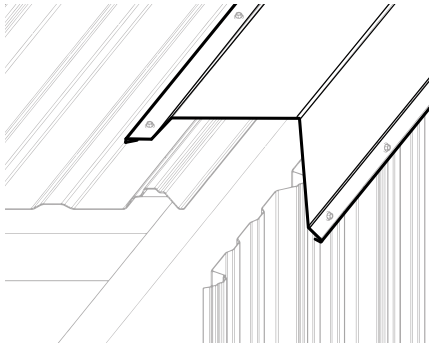

5 Residential Rake

Designed for trimming a sloping roof with the lower level side wall. An extra lip helps reflect precipitation away from the wall panels. Can also be used as an outside vertical corner trim. For best results, use either EmSeal or Sealant Tape to prevent driving wind from carrying rain and debris under the Residential Rake especially if the roof panel does not end with a major rib.

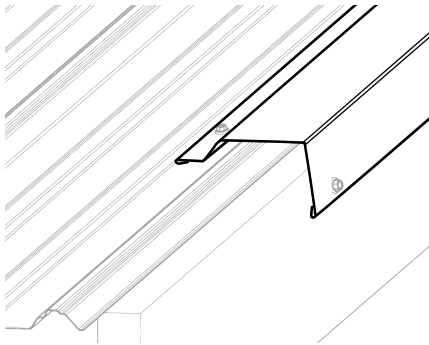

18 D5 Corner

Designed for trimming a sloping roof with the lower level side wall. Can also be used as an outside vertical corner. For best results, use either EmSeal or Sealant Tape to prevent driving wind from carrying rain and debris under the D5 Corner especially if the roof panel does not end with a major rib.

Trim drawings might not be pictured in actual scale.
Please reference the Trim charts for precise trim measurements.

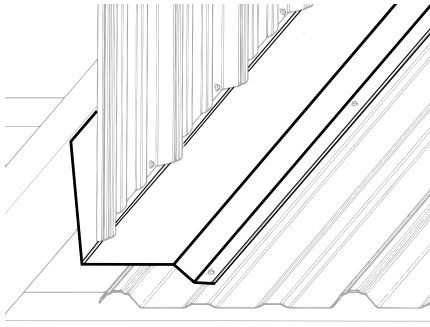

8 Universal Sidewall

Used to join a side wall panel with an adjoining roof panel. For best results, use either EmSeal or Sealant Tape to prevent driving wind from carrying rain and debris under the Universal Sidewall especially if the roof panel does not end with a major rib.

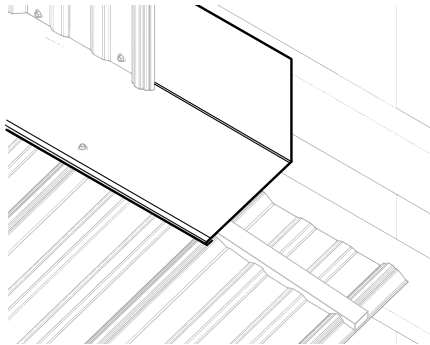

11 Universal Endwall

Designed to finish off a wall that is aligned with the top of a sloping roof. For best results, make sure you use the Outside Foam Filler Strip to prevent driving wind from carrying rain and debris under the Universal Endwall.

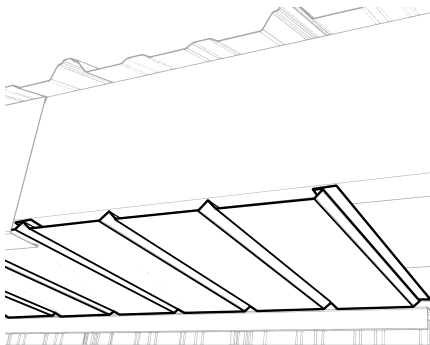

5 12" Soffit (Solid or Vented)

The perfect way to close off the eave of your roof, while also having the option to allow ventilation.

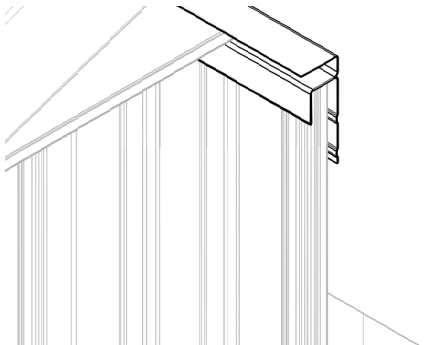

12 OverHang Trim

Commonly used to connect our steel or vinyl soffit with the Metal Panel. Also great for interior use when you need to connect the ceiling panels with the wall panels.

Trim drawings might not be pictured in actual scale.
Please reference the Trim charts for precise trim measurements.

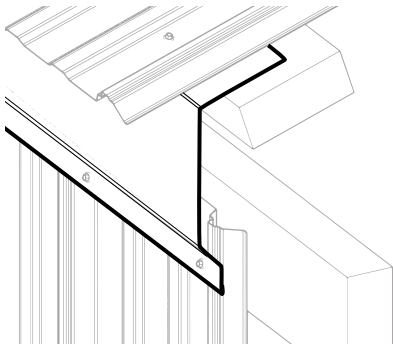

4 Eave Trim

One size in stock to slide under the end of the roof panel and fold down to provide 4 ½" of coverage over your header.

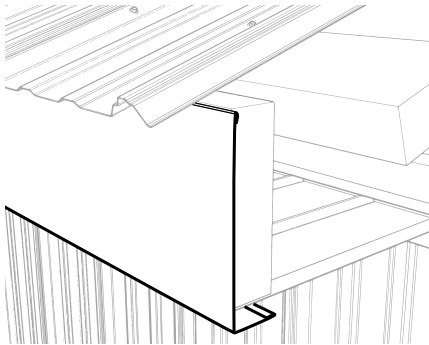

10 Fascia Trim

Multiple sizes to fit most headers and posts in stock. For added protection, consider using the Drip Edge in combination with the Fascia Trim.

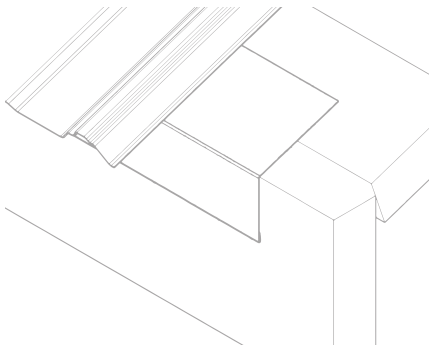

29 Drip Edge

Flat end goes under your roofing, while it includes an extra lip to deflect precipitation away from the wall below.

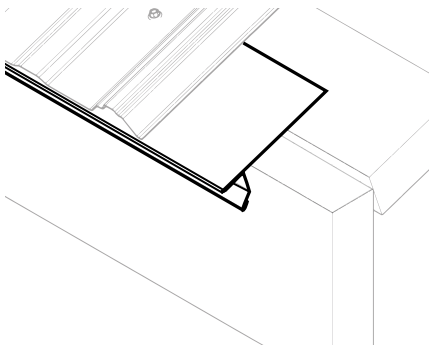

60 Drip Edge

Flat end goes under your roofing, while it includes an extra lip to deflect precipitation away from the wall below.

Trim drawings might not be pictured in actual scale.
Please reference the Trim charts for precise trim measurements.

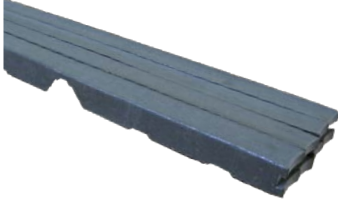

Outside Filler Strips - A 3' long polyethylene foam, pre-cut to conform to the ABM Panel. Closes the gaps to keep out the weather and animals. Most often used at the ridge cap or endwall trim.



BV Foam - 25' Roll of foam for under the ridge cap or in a valley flashing



Ultra-vent - Polyurethane foam compresses and fills the void between your ridge cap and roof panel while allowing air to flow through. Features a factory-applied glue strip. Available in 1" thick x 1.5" wide x 20' rolls and 1.25" thick x 2" wide x 25' rolls.



EMSeal - 19.68' of EMSeal comes compressed into a 0.25x1" roll. Roll it out in a valley or other area that needs to be sealed and it expands up to 1" x 1". Also available in .25" x 1" compressed, 1" x 1" expanded.



Inside Filler Strips - 3' long polyethylene foam, pre-cut to conform to the bottom of the ABM Panel to seal off the eaves.

Caulking - 2300 Geocel caulk comes in a 10.3 fl. oz. cartridge and is available in most of our metal colors.



Sealant Tape - Butyl tape sealant designed for sealing metal lap joints on low-pitched roofs. Comes on a 40' or 45' roll in various widths.



Solex - A radiant heat and vapor barrier available with foil one side and white on the other, or foil on both sides.

