



techtron® Elite 3500

Instruction Manual

Welcome to techtron® by combining passion, drive and intellect with market leading research and cutting-edge technology, we innovate and deliver premium quality products that excite, inspire and challenge the sector.

Striving for perfection, embracing new ideas and investing in the future is our ethos.



Future Tech. Today

Contents

Product and Accessories	4
Assembly	6
Charging	8
Display Panel Function	9
Folding	10
techtron® Smart App	12
Maintenance and Warranty	14
Rider Guidance, Safety and Specifications	17
Troubleshooting	18

IMPORTANT! Read carefully and keep for future reference.

Product and Accessories

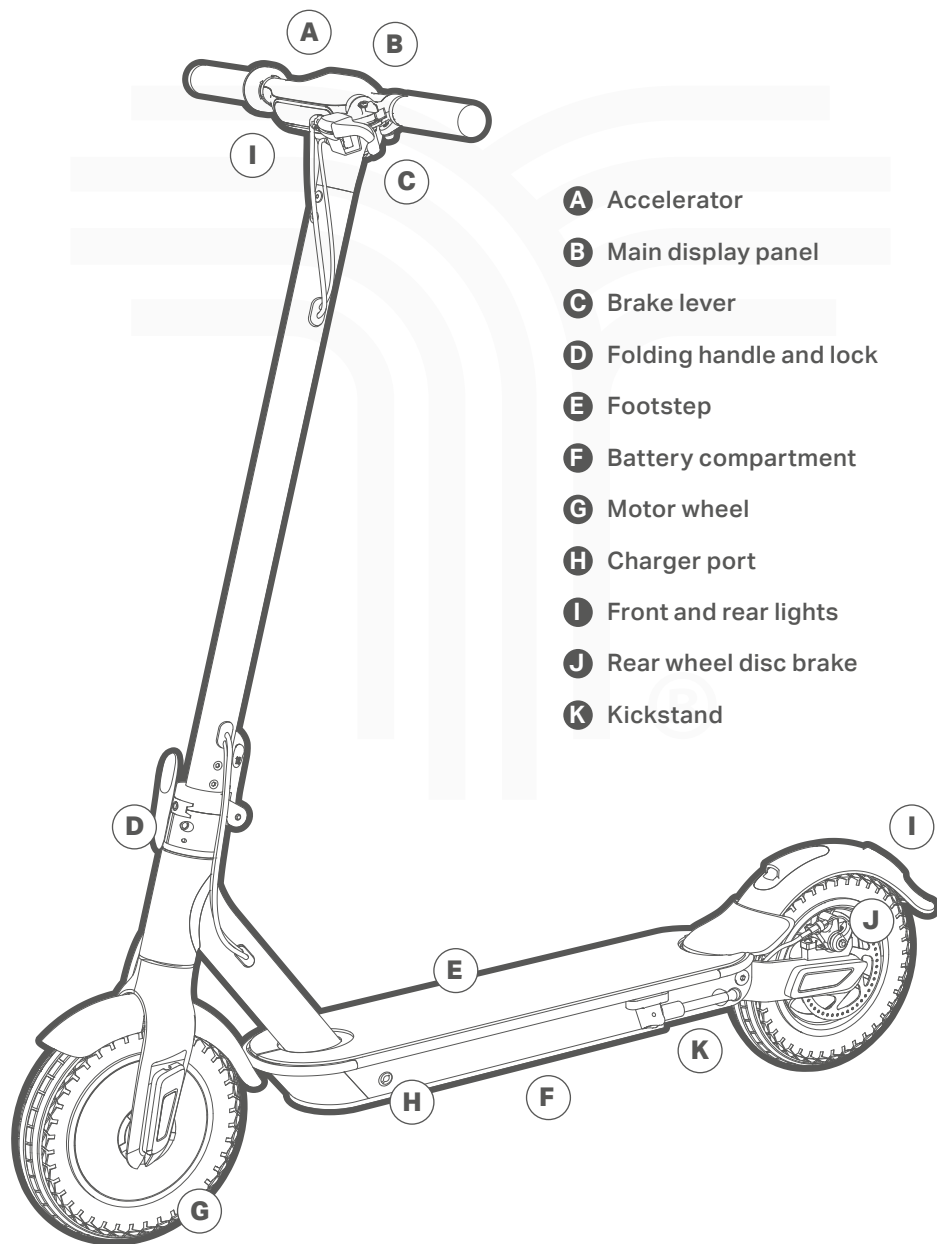

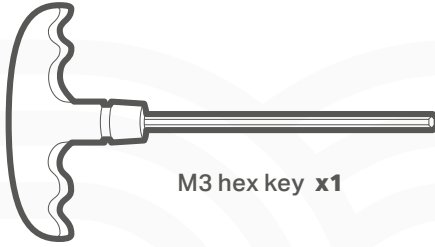

M3 hex key x1

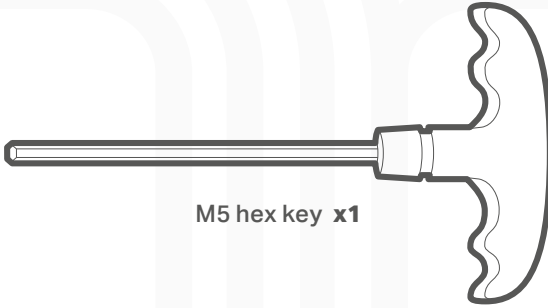

M5 hex key x1



M3 hex screws x4

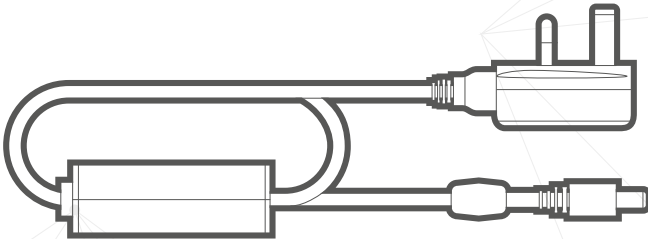

Charging adaptor x1

Assembly

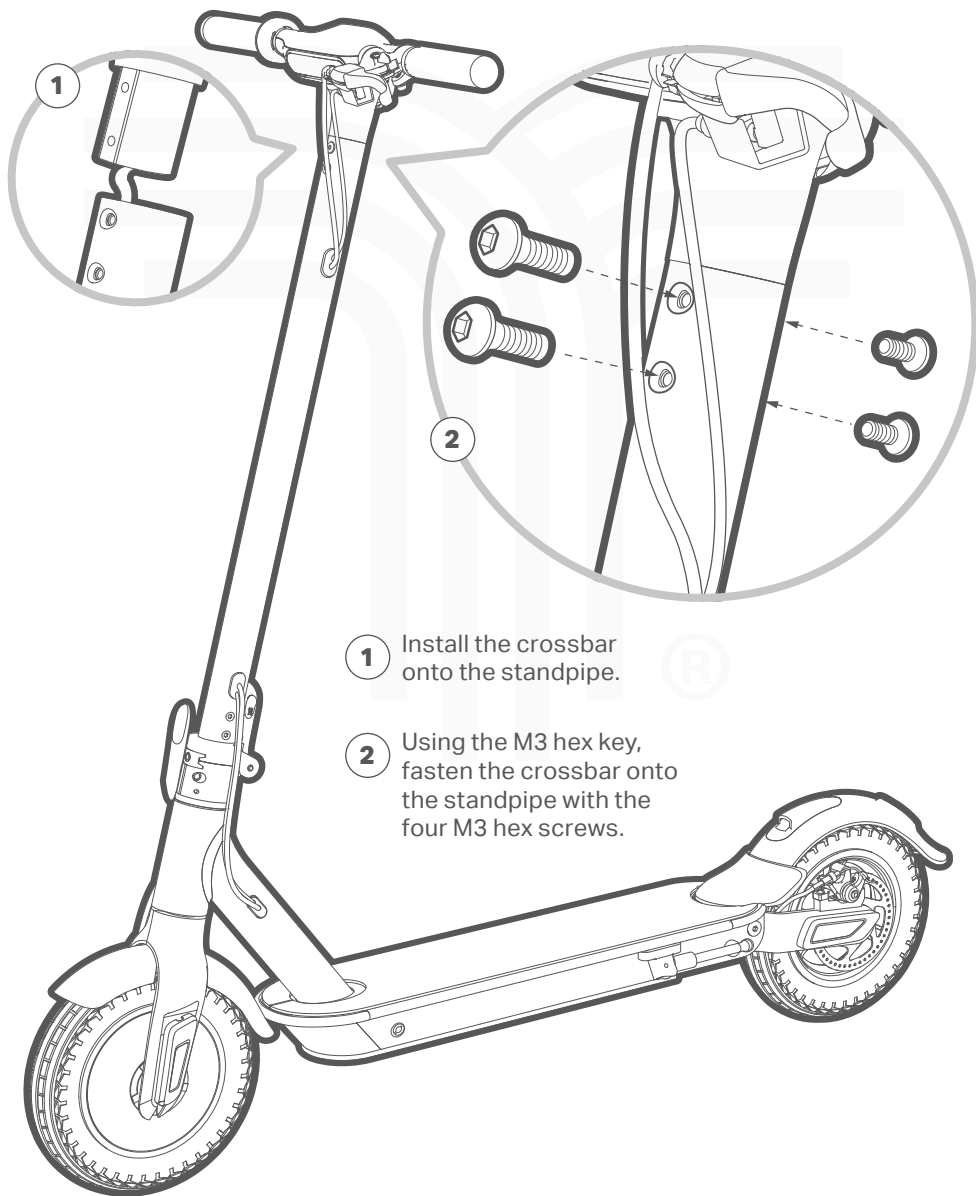

- 3** Unfold the scooter standpipe, move the handle into position and lock the folding mechanism in place.

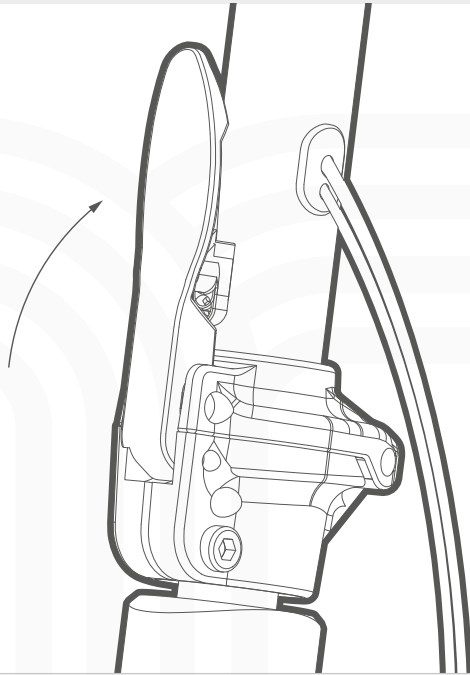

- 4** Make sure the brake lever is installed in the desired position. Use the M5 hex key to loosen and tighten the fixing.

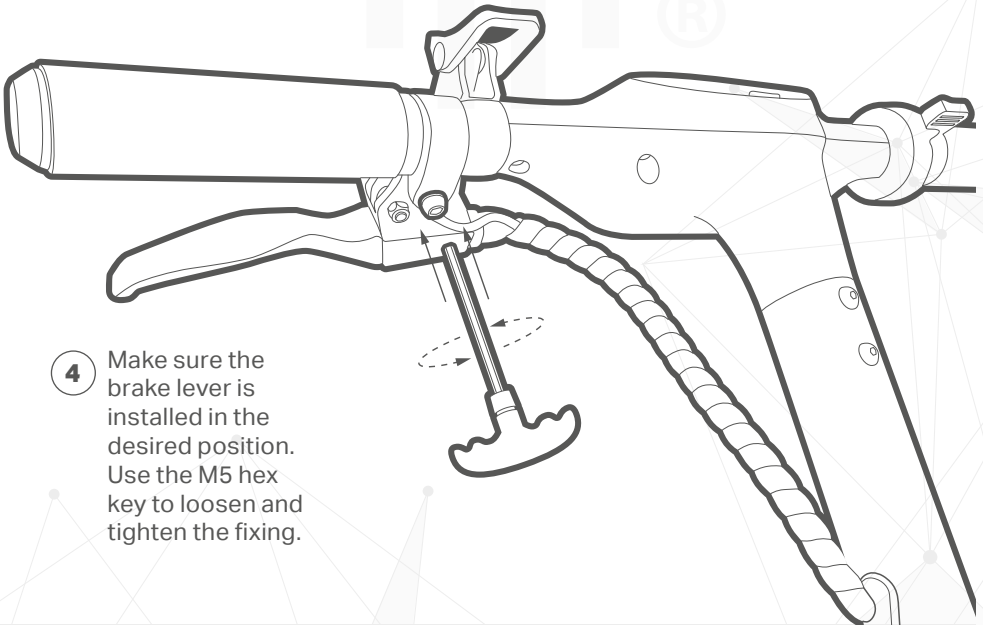

Charging

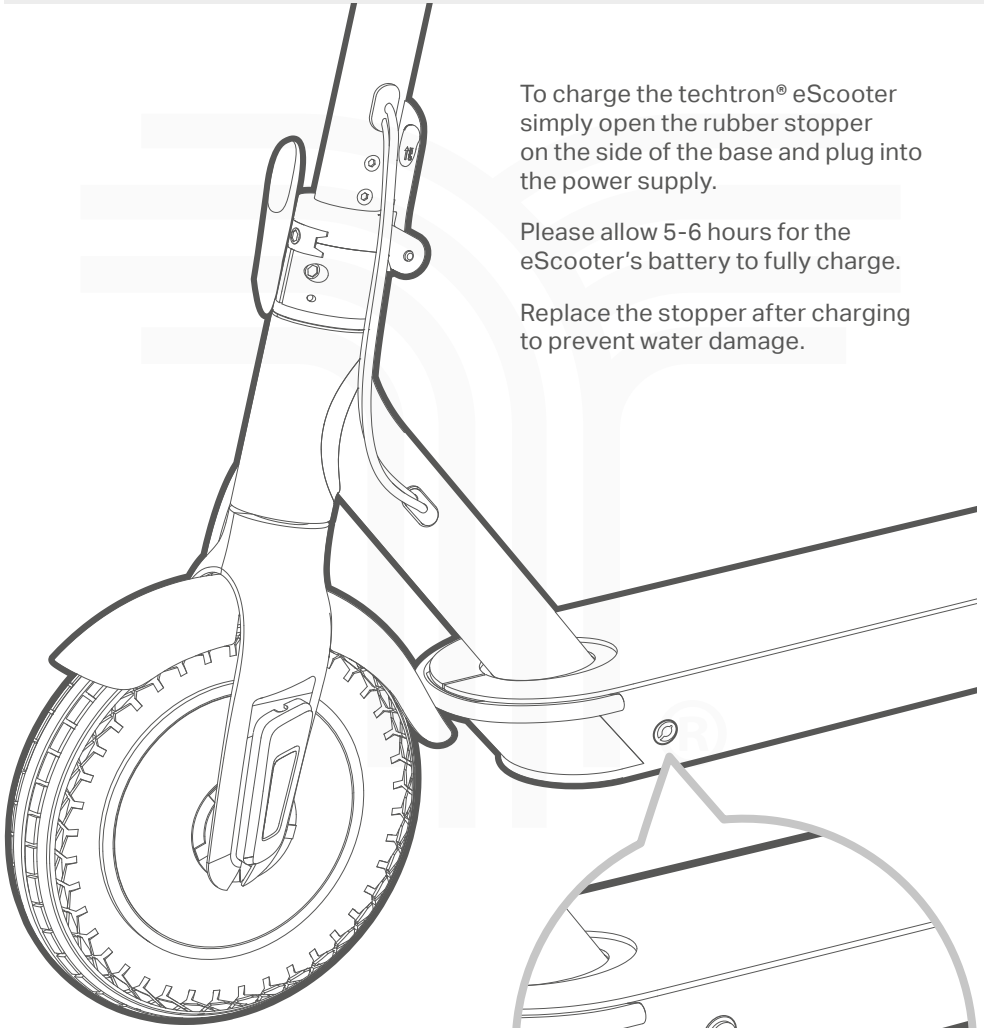

To charge the techtron® eScooter simply open the rubber stopper on the side of the base and plug into the power supply.

Please allow 5-6 hours for the eScooter's battery to fully charge.

Replace the stopper after charging to prevent water damage.

Battery level indicator

Five bars along the top edge of the display panel indicate the current charge status. When only a single bar remains, electricity is less than 10% and the scooter will eventually slow to a natural stop and must then be re-charged.

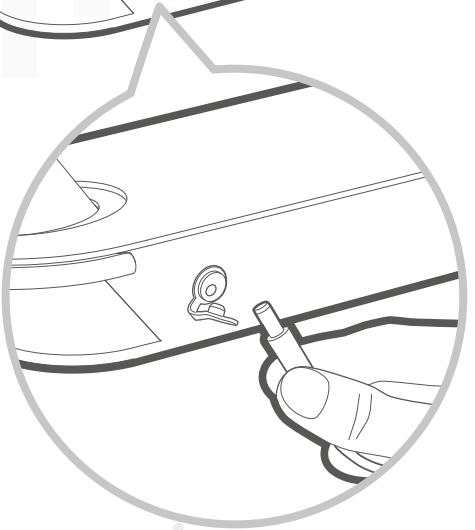

Display Panel Function

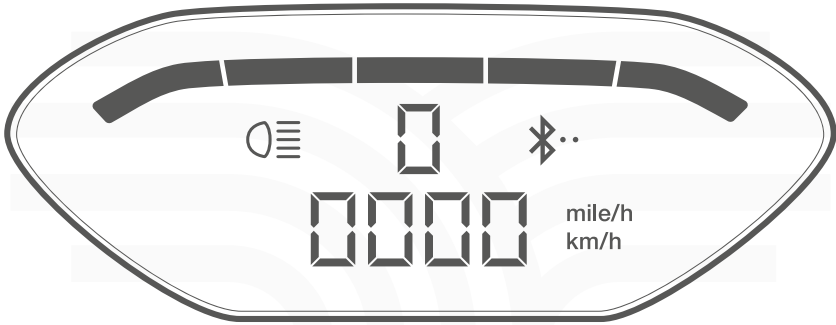

Speed display

The techtron® Elite 3500 foldable eScooter is capable of a maximum speed of 25km/h, with three pre-configured factory default speed modes.

These presets can be changed via the techtron® smart app (see page 12). The app allows the user to set a pre-determined speed for each speed mode. The display can also be configured to show speed in mph or km/h using the techtron® app.

Factory default speed modes	
Speed mode	Maximum speed
1	10km/h
2	15km/h
3	25km/h

Display panel button

To turn the eScooter ON/OFF, hold down the button on the main display panel for two seconds. With a quick press of the same button, the user can toggle between the device's three-speed mode presets. The eScooter's main light can also be turned ON/OFF by a quick double press of the same button. Press the button three times to display the total distance travelled, then press another three times to display your speed again.

Cruise control

To activate cruise control mode press and hold the accelerator at the same speed for five seconds, the device will beep when the mode is activated. Cruise control will deactivate when applying the brake.

Power saving

When not in use the techtron® eScooter will power down automatically after 15 minutes.

Folding

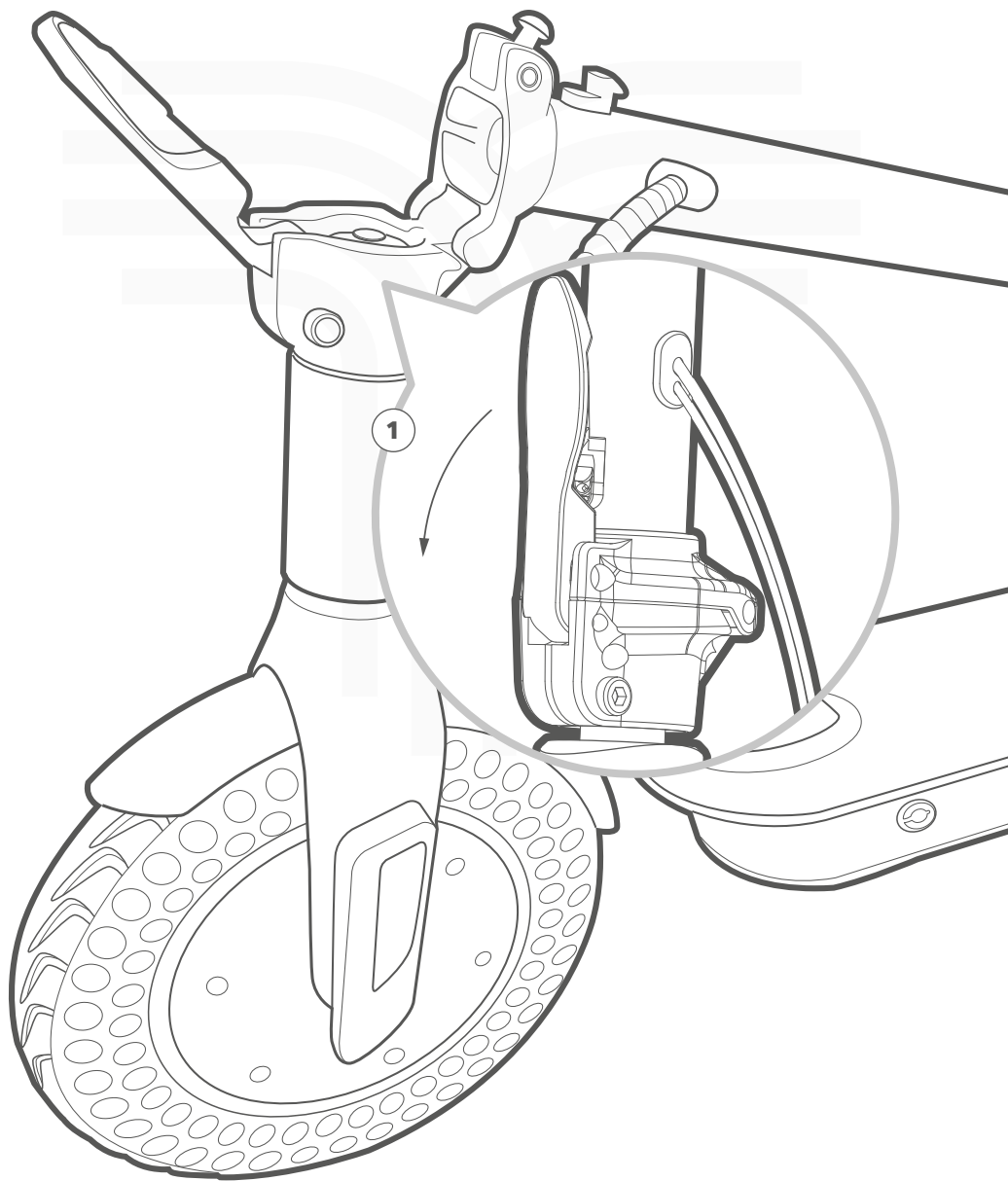

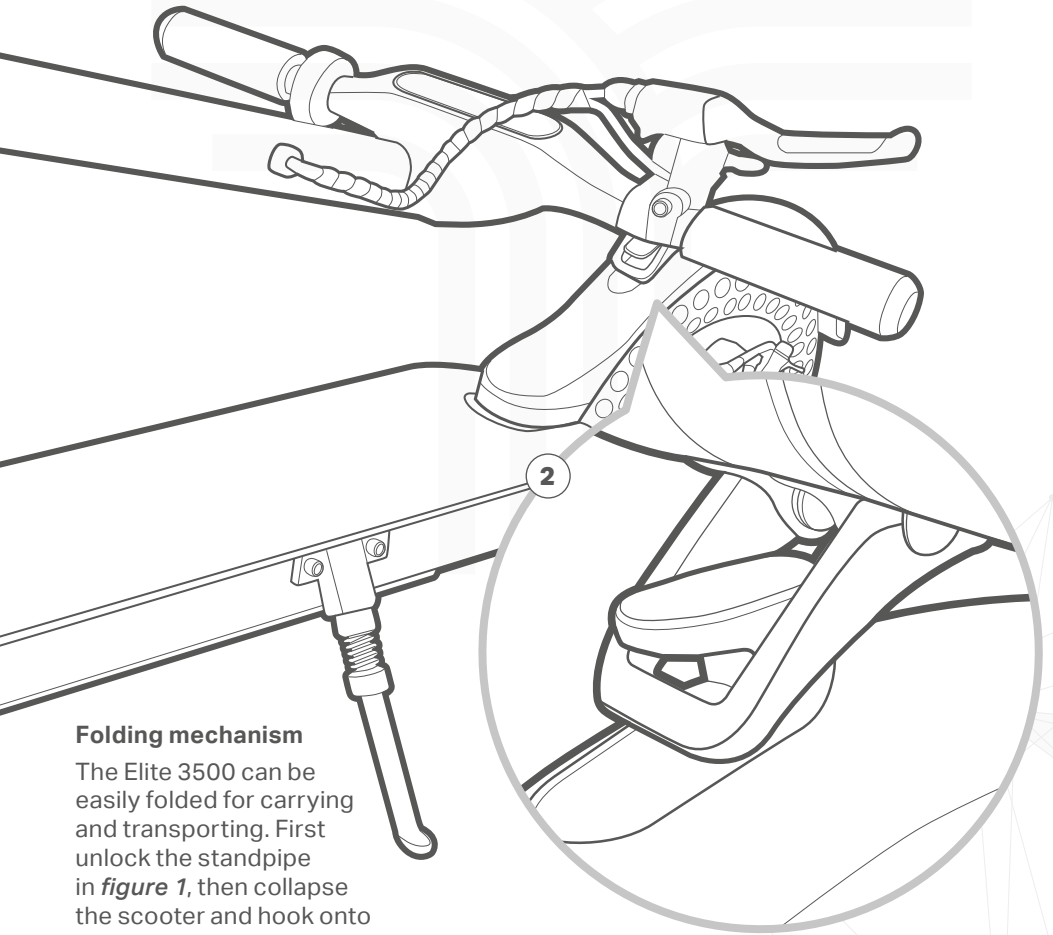

Folding mechanism

The Elite 3500 can be easily folded for carrying and transporting. First unlock the standpipe in *figure 1*, then collapse the scooter and hook onto the folding clasp located on the rear mudguard as shown in *figure 2*.

techtron® Smart App



Your eScooter can be configured using the techtron® smart app. Use it to set up your desired settings such as riding mode and speed limiter. You can even lock the scooter to prevent unauthorised access.

Please note - the eScooter will remember all settings applied in the techtron® smart app even when Bluetooth® is disconnected.

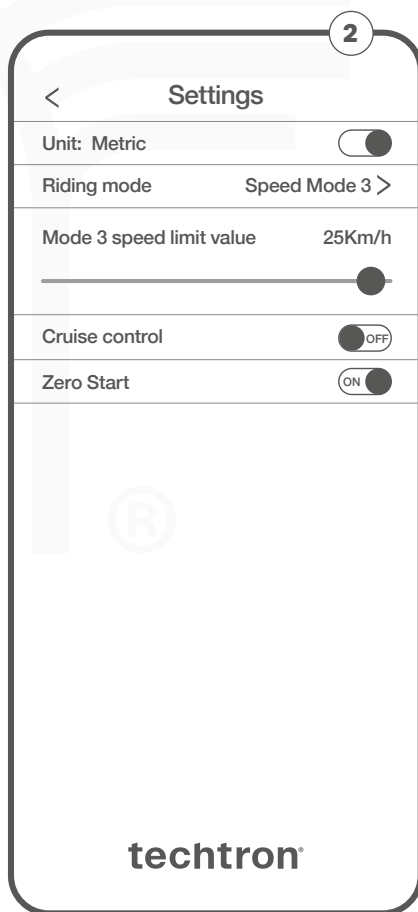
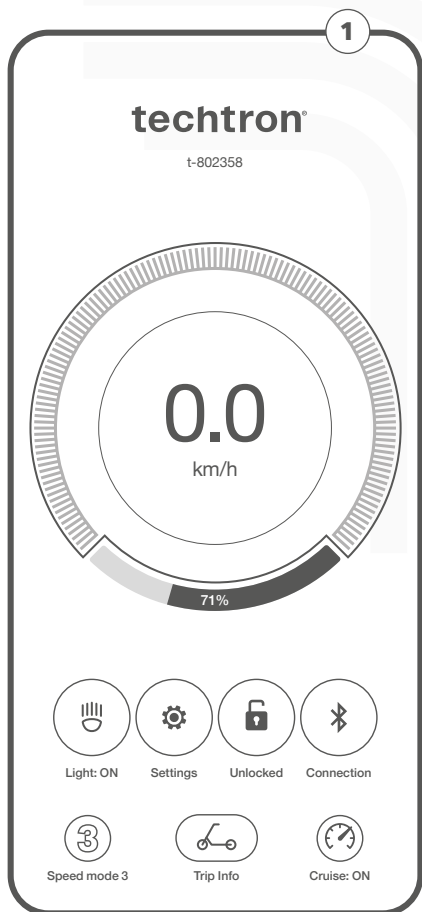

Download to your smart device via the Apple App Store or Google Play.



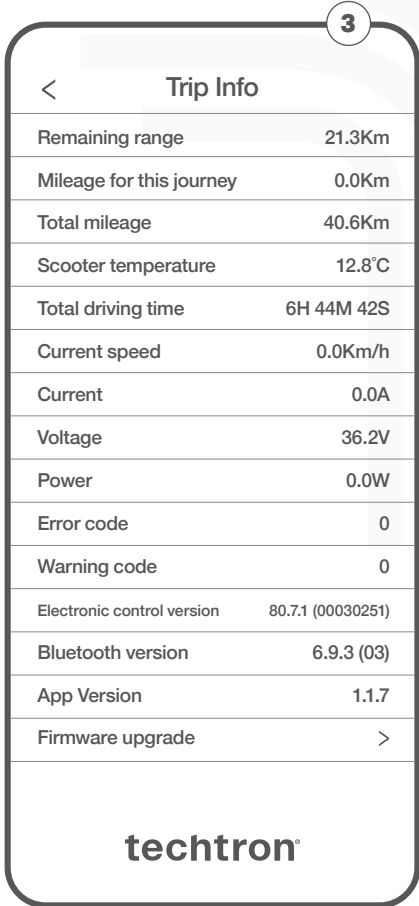

1 Home screen

View the remaining range of your eScooter, so you can plan your journey.

Light - Turn the main light On/Off.

Settings - Access further controls.

Lock - Secure your eScooter against unauthorised access.

Connection - Discover and pair your eScooter to your smart device.

Riding mode - Toggle between riding modes

Trip info - View the latest trip information.

Cruise control - Quickly toggle this option On/Off.

2 Settings

Unit - Change the unit of measurement used to display your speed from km/h to mph.

Cruise control - Maintain a constant speed for those longer journeys.

Riding mode - Choose your preferred speed preset (options vary depending on model).

Speed limiter - Control how fast the scooter can go if being used by children.

Zero start - Enable the option to start your eScooter from stationery position (enabling this option can reduce battery range).

3 Trip info

View your eScooter's latest trip information, anything from total driving time to voltage and power statistics.

The device firmware can also be upgraded by the user from this menu (internet connection required).

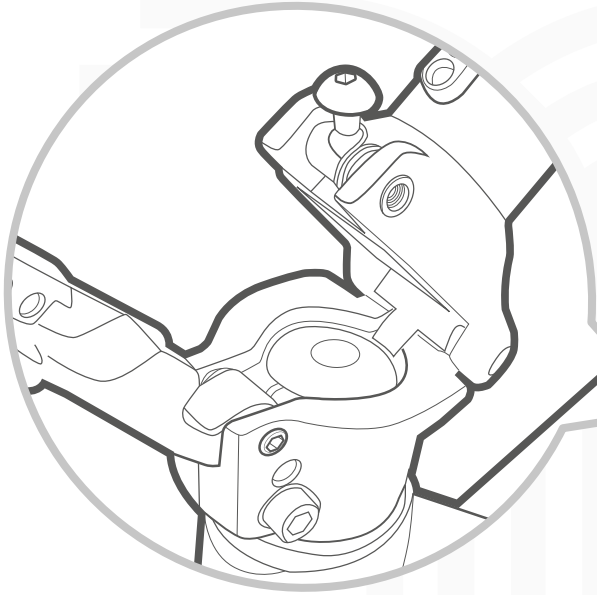

Standpipe shake

Should your eScooter's standpipe develop a slight shake over time, it may be necessary to tighten the two folding mechanism screws, using the M3 hex key.



Brake adjustment

To tighten the brakes, simply insert the M5 hex key into the slot and turn counterclockwise to release the pressure plate screw. Return the brake line to make the exposed tail length slightly longer, then lock the pressure plate screw.

If the brakes are too tight, release the pressure plate screw again and pull the brake cable to make the exposed tail length slightly shorter, then lock.

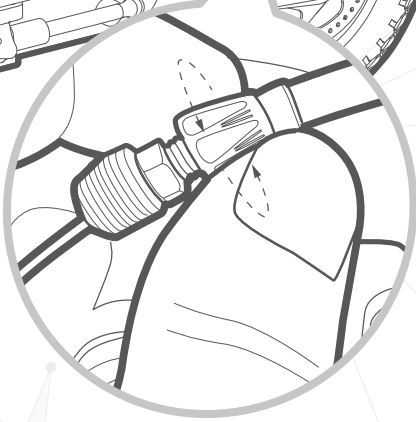
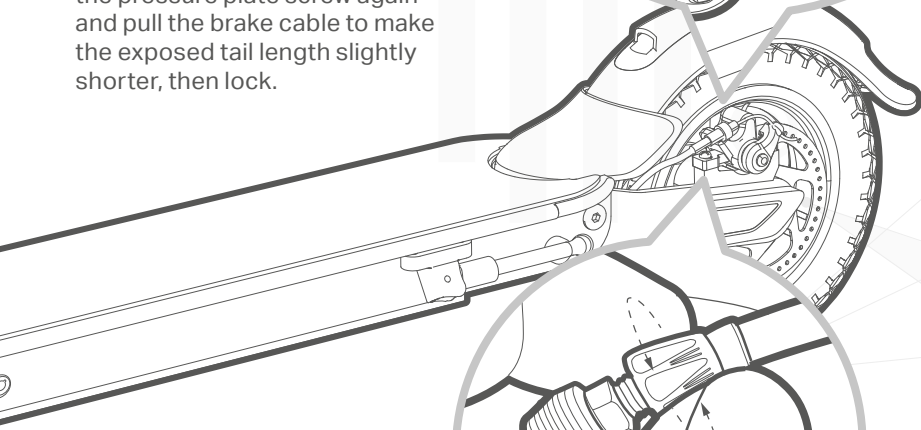
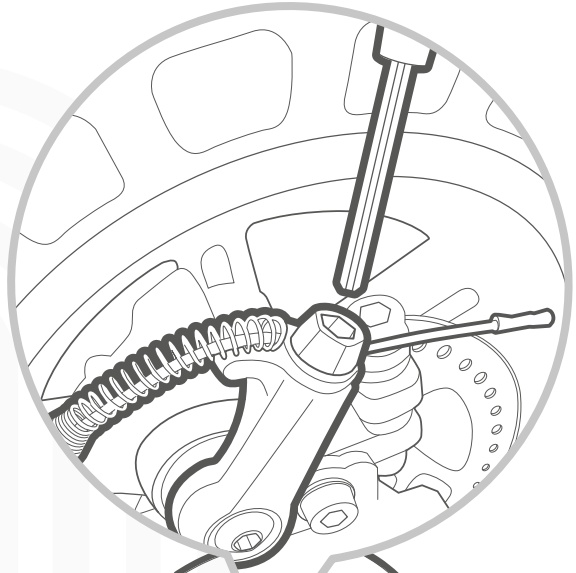

Fine tuning loose or tight brakes

The brakes can be fine tuned by hand. Turn the screw counterclockwise to tighten the brakes and clockwise to loosen.

Maintenance and Warranty

Cleaning and storage

Use a soft cloth dipped in a small amount of water to wipe the eScooter; for any difficult to clean areas, you can use toothpaste and gently brush with a toothbrush, then use a damp cloth to clean.

Do not use alcohol, petrol, kerosene, or other corrosive, volatile chemical cleaning solvents, as this will seriously damage the appearance and internal structure of the body. Do not use pressure washers to clean. Ensure that the charging cable has been unplugged and the rubber stopper on the charging port is closed. Otherwise, there may be a chance of electric shock or serious failure due to internal water intake.

Warranty policy

techtron® offers a one-year guarantee on rechargeable batteries. Two-year guarantee against parts and/or manufacturing defects, Terms & Conditions/Exclusions apply, please see website for further details.

Product registration

For exclusive offers, product support and information on the latest techtron® innovations, register your product by completing the form on the website with your serial number and details - <https://techtron.co/pages/warranty>

Battery maintenance and disposal

Do not touch the battery contacts, and do not open or expose the shell. Avoid metal objects touching the battery contacts, as this will cause a short circuit, damage to the battery, or even personal injury.

Please refer to the model specifications in this manual for your eScooter's charging requirements. Only use a charger with the correct voltage otherwise there will be a risk of damage to components or fire.

Ensure batteries are disposed of responsibly. Recharge the battery and store after use, in order to preserve battery life. Do not place the battery in high temperatures higher than 50°C or below -20°C, or it may lead to battery failure, overheating, or even risk of fire. Always store in a cool dry place fully charged. A battery will be at optimum performance at a standard room temperature. Warranty may be invalid if the battery is removed.



This marking indicates that this product should not be disposed with other household wastes throughout the EU. To prevent possible harm to the environment or human health from uncontrolled waste disposal, recycle it responsibly to promote the sustainable reuse of material resources. To return your used device, please use the return and collection systems or contact the retailer where the product was purchased. They can take this product for environment safe recycling.

All product images shown in this instruction manual are for illustrative purposes only and may differ slightly from the actual product.

Rider Guidance, Safety and Specifications

Helmets and clothing

Wearing cycle helmets are recommended when riding an eScooter, but they are not a legal requirement. Always make sure that your cycle helmet conforms to current regulations, is the correct size, and is securely fastened. Wear light-coloured or fluorescent clothing so that other road users can see you at night or whenever visibility is poor.

As with any vehicle, the faster the user is travelling, the more braking distance is required. Please respect pedestrians' right of way when riding the techtron® eScooter.

Riding safely

Please check the eScooter before riding. Check for loose parts and general tyre wear and tear.

Always start the eScooter by pushing off with your foot first, this reduces the start load on the motor, ensuring a longer battery life.

The techtron® eScooter is designed to perform best on smooth dry surfaces, therefore avoid riding on uneven gravel, sand, grass, slick or wet surfaces. Never ride over curbs or jump. The eScooter is not designed for this type of riding and any damage caused to the eScooter while riding in this manner will void the warranty.

techtron® accepts no liability for any injuries caused to rider or damage to property which may arise while riding the eScooter. Never ride the scooter with more than one person, as this may lead to loss of control. It is the rider's responsibility to ensure they comply with all local laws and regulations that may apply while riding the eScooter.

Model specifications

Model	Elite 3500
Range	30km
Power	350W
Top Speed	25 km/h
Speed Modes	3
Hill Incline	15%
Rider Age	16-50 years
Max. Load	120kg
Battery	37V 10Ah
Charger	42V/2A
Storage Temp	-20°C to 45°C
Working Temp	-10°C to 40°C
Rider Height	120cm - 200cm
Frame Material	Aluminium
Current Limit	16A +/- 0.5V
Motor Type	Brushless DC
IP Rating	IPX4
Foldable	Yes
Tyre Size	10"

Any enquiries regarding maintenance, accessories, security or warranty, please visit the techtron website:

www.techtron.co

or email us:

info@techtron.co

Rules of the road and licensing guidance

For the latest up-to-date safety, licensing guidance and rules of the road for UK eScooter users, please consult the UK Government website:

www.gov.uk/guidance/e-scooter-trials-guidance-for-users

Troubleshooting

Error codes and what they mean

Faults with techtron® eScooters rarely happen, but if you're unfortunate enough to encounter a problem, just cross reference the error code shown on the scooter's display panel with the ones listed in the table opposite.

If the fault can't be resolved through simple troubleshooting, and providing your scooter is in warranty, then get in touch with our customer services team. Let us know the error code displayed on your scooter, or give us an idea of the problem you're having and we'll do our very best to get you back up and riding as soon as possible.

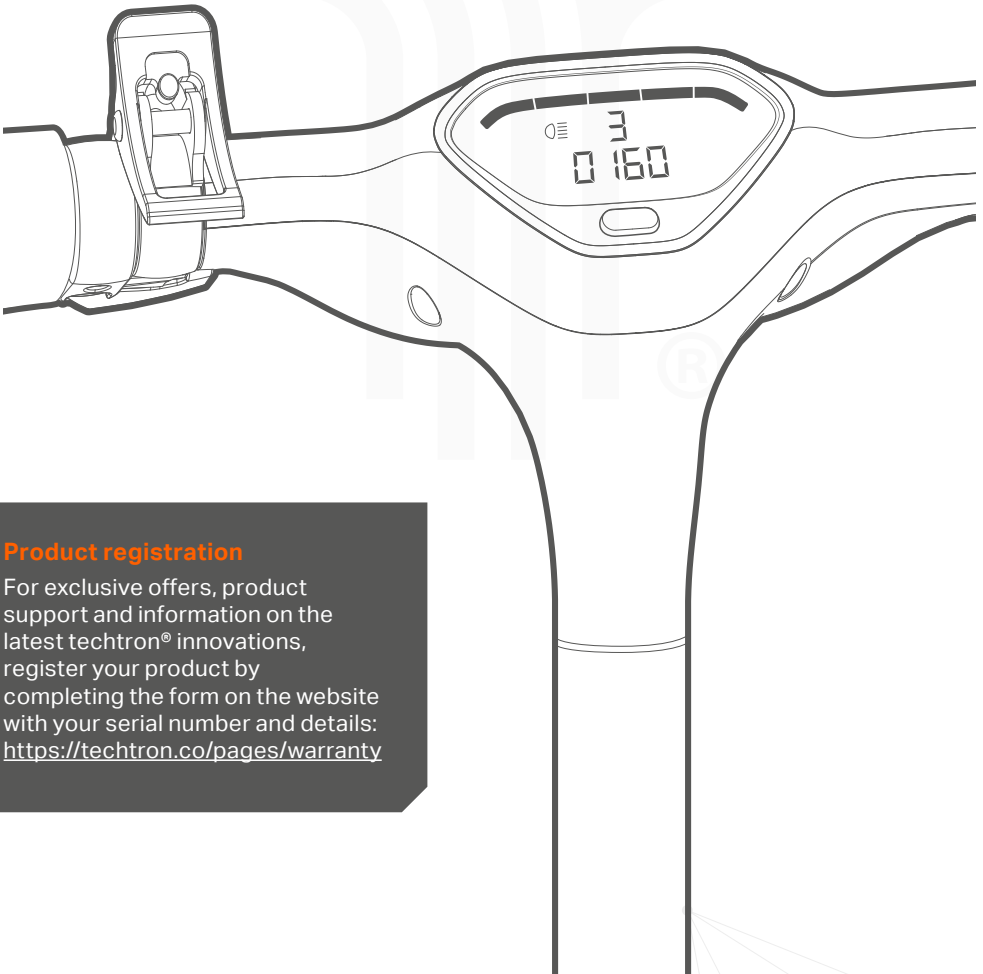

Product registration

For exclusive offers, product support and information on the latest techtron® innovations, register your product by completing the form on the website with your serial number and details: <https://techtron.co/pages/warranty>

Error code	Description	Solution
4	Short circuit	Check for a short circuit in the wiring/installation or replace the controller to eliminate the fault.
9	Sub-motor communication failure (dual drive models only)	Check the connection line between the secondary and primary controller.
10	Display panel communication failure	First check the connection wire between the display panel and the controller assembly line. Then shut down the eScooter, re-plug the assembly line interface and restart. If the fault has not disappeared, instrument or controller may need to be replaced to eliminate the fault.
11	Abnormal motor current sensor	Check the line of the phase line of the controller or motor.
14	Throttle hall anomaly	Check whether the throttle is reset to zero, whether the throttle cable and throttle are normal or not. Unplug the throttle cable and restart the eScooter to troubleshoot the problem.
15	Brake hall anomaly	Check whether the brake is reset to zero position or not, check the brake line and the brake normal or not. Try unplugging the electronic brake wiring and restarting the eScooter to eliminate the problem.
16	Motor hall anomaly	Check that the motor hall wiring looks normal. If problem occurs when braking, the motor or controller will need to be replaced.
19	Secondary motor hall anomaly (dual drive models only)	Check that the secondary motor hall wiring is normal. Replace motor or controller to eliminate the problem.
21	BMS communication anomaly	BMS communication abnormal (non-communication battery is ignored).
50	Bus high voltage	Check the battery voltage is normal, cycling failure. Replace the battery or controller to eliminate the problem.
53	System overload	Shutdown and restart the eScooter. If the error code is still displayed, the controller needs to be replaced.
55	Controller high temperature alarm	If the temperature of the controller is too high, allow the eScooter to cool and then restart. If vehicle fails to boot, the controller will need to be replaced.

techtron®

For further information and advice you can find us at:

**techtron® Unit 2, Jowett Street,
Bradford, BD1 2JX. UK.**

e: info@techtron.co

t: 01274 307310

w: techtron.co

**Research & Development 2100 Geng Road, Suite 210,
Palo Alto, California, 94303 USA.**

e: info@techtroncalifornia.com w: techtroncalifornia.com

techtron® is a division of Multibrands International Ltd.