

ASSEMBLE Top Seat, Vertical and Cover 8RI FRAME

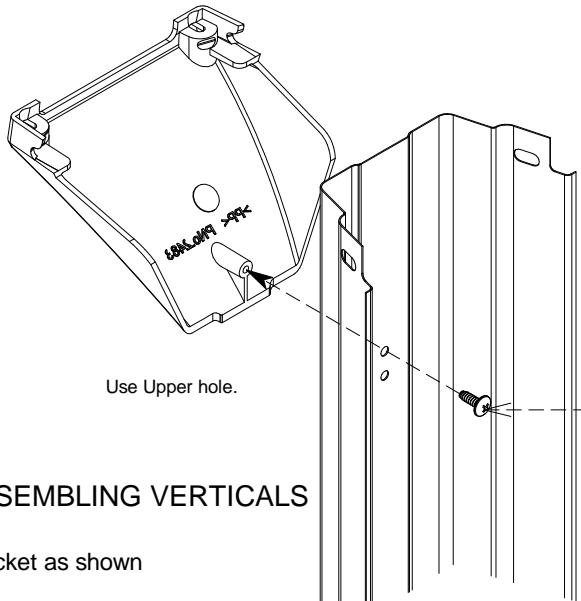

Use Upper hole.

a) PRE-ASSEMBLING VERTICALS

Put cover bracket as shown in the figure.
Tighten up #12 Sheet Metal Screw.

Put Resin Upper Joint as shown in the Figure, tighten up #12 Sheet Metal Screws.

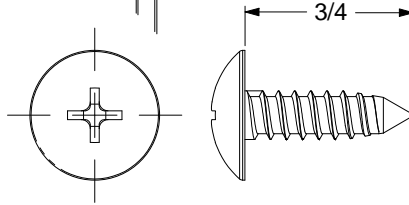

P.No.0341
#12 Sheet Metal Screw

c) INSTALLING TOP SEATS

Place each of the top seat over the upper joints and secure with #12 Sheet Metal Screws.

Install all of top seat in this way around entire pool.
Top seat are installed between verticals.
Each end of top seat rest on upper joint and attached to it.
It may be necessary to move the complete verticals slightly to left or right to accommodate the top seat.
Do this carefully as not disturb the earth mound, Check all screws to be sure they are tight.

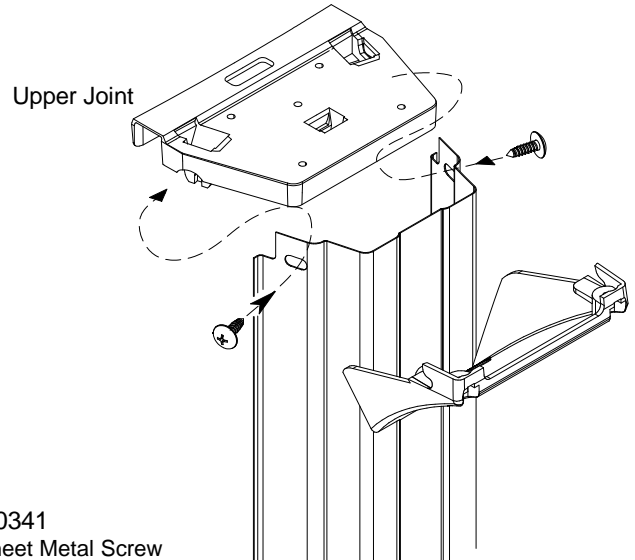

Upper Joint

P.No.0341
#12 Sheet Metal Screw

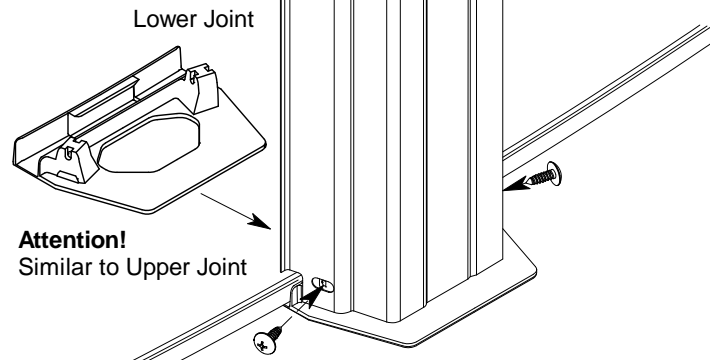

Lower Joint

Attention!
Similar to Upper Joint

b) INSTALLING VERTICALS

Hook Assembled Resin Upper Joint over the top rail. Secure the bottom of vertical to Resin Lower Joint by #12 Sheet Metal Screws, Continue installing verticals in this manner All around the pool.

For 12' round and all 10' and 12' width ovals use different screws for right and left end of the top seat as shown figure.

END ; A use shorter screws. **END ; B** use longer screws.

P.No.0345
5mmx40 Sheet Metal Screw

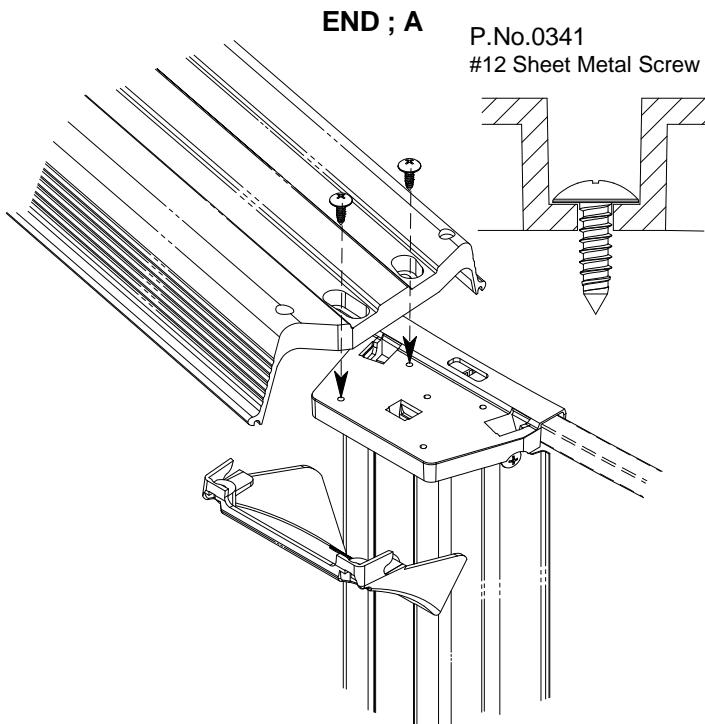

END ; A

P.No.0341
#12 Sheet Metal Screw

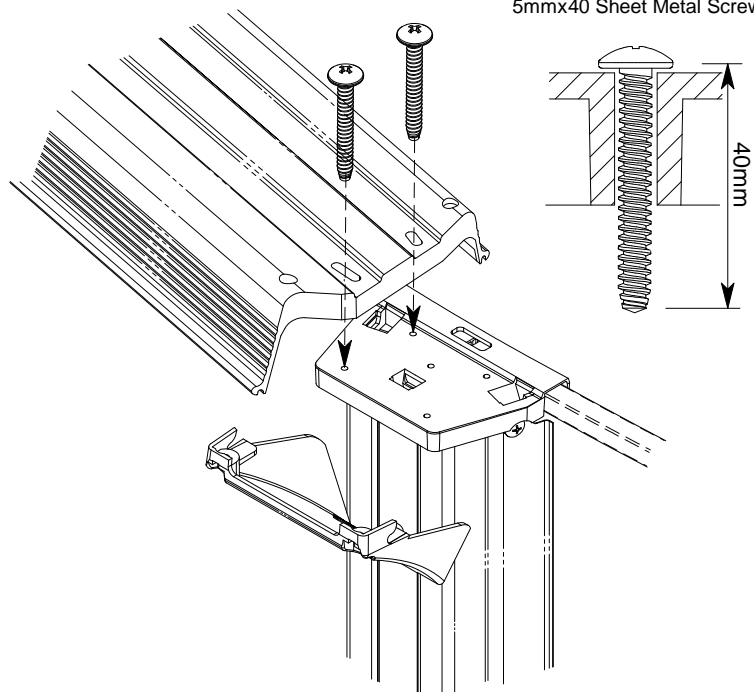

END ; B

P.No.0345
5mmx40 Sheet Metal Screw

40mm

d) INSTALLING SEAT COVERS

P.No.0345
5mmx40 Sheet Metal Screw

Attach seat cover by placing it from inside of pool in right position as shown in the figure.
put seat cover and cover bracket together, Insert #12 Sheet Metal Screw from cover bracket to seat cover, and tighten it up. put 5mmx40 Sheet Metal Screw to seat cover and tighten it up. put seat cover cap on top of cover.

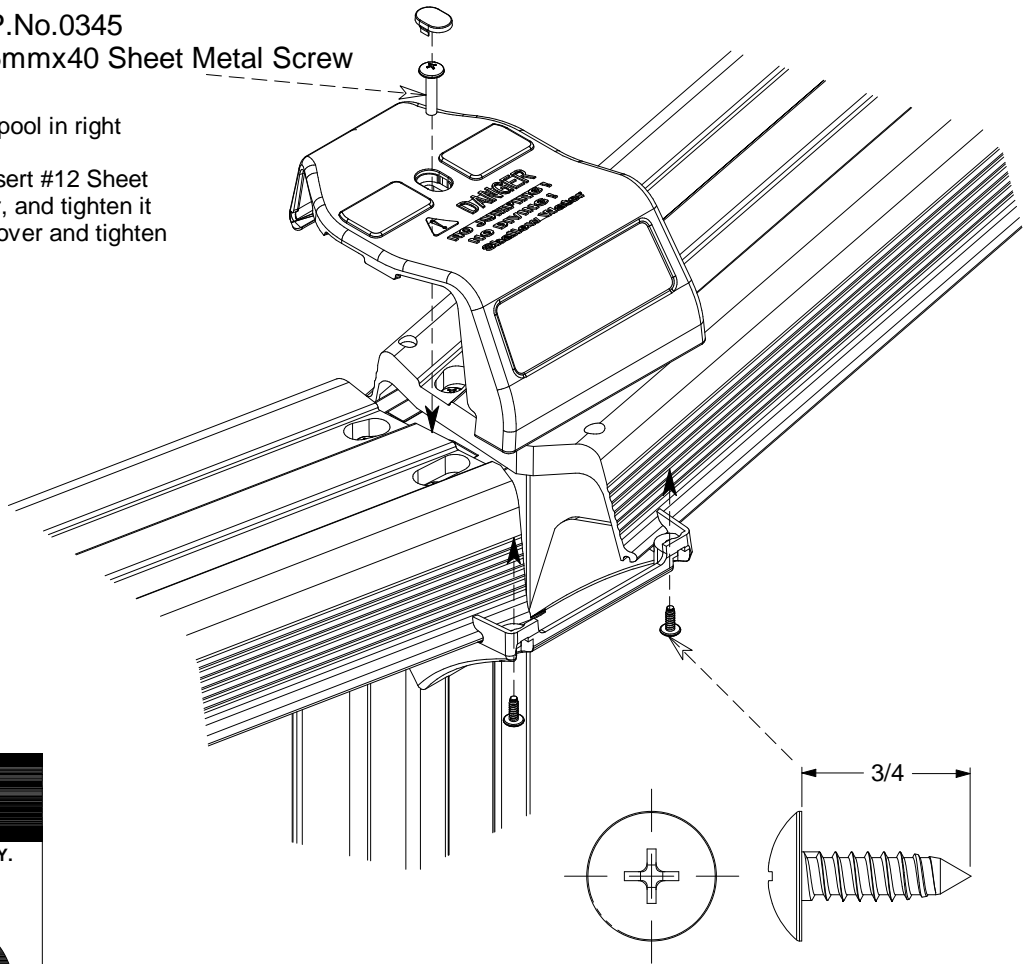

P.No.0341
#12 Sheet Metal Screw



P.No.0345
5mmx40 Sheet Metal Screw

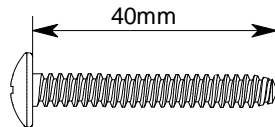

FOR OVAL POOL ONLY

e) INSTALLING OVAL SIDE TOP SEATS AND SIDE SEAT COVERS.

use #12 Sheet Metal Screw to Install oval side top seats on top of Resin side upper joint P.No.3177. then attach side seat cover by placing it from inside of pool in right position as shown in the figure.

Put 5mmx40 Sheet Metal Screw to side seat cover and tighten it up. put seat cover cap on top of side seat cover.

10' and 12'width ovals use different screws for right and left end of the top seat.

Please refer section. "c) Installing top seat "
End A use P.No.0341 #12 Sheet Metal Screw,
End B use P.No.0345 5mmx40 sheet metal screw.

