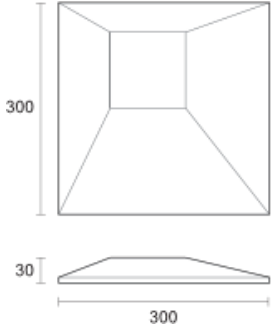
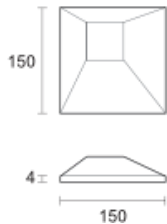

## 3DFORMS CORK WALL TILES

### TECHNICAL SPECIFICATION

#### GENERAL DEFINITION AND PRODUCT COMPOSITION

Definition	Solid agglomerated cork tiles to be used as wallcoverings within buildings, contributing significantly to the acoustic and thermal performance of buildings, improving environmental comfort and reducing energy costs. Tiles are shaped by CNC machining (3 different shapes and 2 different sizes) and finished with a waterbased protector for increased water and stain resistance.	
------------	---	--

Dimensions	Art. 311 XXX XXX 300x300x30 mm	Art. 310 XXX XXX 150x150x30 mm
		

Product structure and materials	 <p>Granulated cork 2.0-3.0 mm size and 45/50 Kg/m<sup>3</sup> density. Polyurethane cork binder. CORKGUARD® Aqueous dispersion (clear or coloured).</p>
---------------------------------	--

Installation system	Glued
---------------------	-------

#### TECHNICAL DATA

Length and width	EN ISO 24342	300 x300 mm ± 0.5 % 150 x 150 mm ± 0.5 %
Overall thickness	ISO 7322	30 mm ± 0.5 mm
Density	ISO 7322	200 Kg/m <sup>3</sup> ± 5 %
Moisture content	EN 12105	< 8 %
Resistance to boiling water	ISO 7322	No disintegration
Reaction to fire	EN ISO 11925-2 EN 13501-1	Extent of flame < 150 mm. No flaming droplets/particles Fire class E



## 3DFORMS CORK WALL TILES

### TECHNICAL SPECIFICATION

TECHNICAL DATA		
Formaldehyde emission	EN 12149	Fulfilled. Below Detection Limit (DL=0.1 mg/kg) No formaldehyde-containing products are added during the manufacturing.
Heavy metals and specific elements Arsenic; Barium; Cadmium; Chromium; Mercury; Lead; Antimony; Selenium	EN 12149	Fulfilled None of these substances are added or have come in direct contact with the product during the manufacturing process
Release of vinyl chloride monomer	EN 12149	Fulfilled Below Detection Limit (DL=0.08 mg/kg)
Determination of the sound absorption in a reverberation room	EN ISO 354 EN ISO 11654	Weighted sound absorption coefficient $\alpha_w = 0.1$
Thermal resistance Thermal conductivity	EN 12667	0.614 (m <sup>2</sup> .K)/W 0.048 W/(m.K)
Sound absorption	ISO 354	Weighted sound absorption coefficient $\alpha_w = 0.1$

GENERAL DATA	
Features	Safe and easy to handle and install; Effective reduction of airborne sound; Increases the thermal comfort; Persistence of characteristics along time; Without the release of toxic gases when burning; Lightweight, elastic and odourless; No harmful chemicals; Contains 92% of post-industrial recycled content; Natural, biodegradable and recyclable product; Product certified FSC Controlled Wood SA-CW-002408.
Packaging	3DForms tiles are packed in cardboard cartons, each containing 72 modules 150x150 or 18 modules 300x300, providing suitable protection for normal transport and storage conditions.  Tiles per carton: 72 (150x150mm) or 18 (300x300mm) Sqm per carton: 1.62 m <sup>2</sup> Weight per carton: 6 Kg Cartons per pallet: 42 Sqm per pallet: 68 m <sup>2</sup>
Lifetime limited warranty	We certify that the product is free from manufacturing and structural defects and will remain free of these defects.
Environment	3DForms tiles are made using more than 90% cork, which is a renewable raw material. It contains no PVC and no softeners or other substances hazardous to health or the environment.



Our supplier reserves the right to make changes to material and structure to improve the quality or technical performance.