

Outdoor | 15" Clear Ice Machine Individual Cube: Gravity Drain and Pump Models



- Produces up to 63 lbs of 1½" x 1½" x 1¼" clear individual cubes per day
- Bin stores up to 25 lbs of clear ice
- Clear ice scoop and storage hook included
- Signature SAPPHIRE blue interior
- Fully wrapped stainless-steel exterior
- Articulating, concealed self-closing hinges with built-in door stop
- Multifunction capacitive touch electronic control
- Auto shut-off when ice bin is full
- Alert notifies when time to initiate easy cleaning process
- Quiet mode feature can be set to suspend ice-making production during specific times of the day
- Full LED theater lighting
- Unit ships right hinged with field-reversible doors
- 1" Diameter stainless steel handle with faceted standoffs (26" length)
- Precise zero clearance design allows for unmatched integration into any built-in setting
- 4 Independent adaptable leveling legs
- Fixed louvered stainless steel grille
- Installation requires a customer-supplied water line and includes a 10 ft factory-installed drain line
- Gravity drain and factory-installed pump models available



Stainless

Model Details

Model	Pump	Finish	Description	Shipping Weight
SIIM15-GD-OD	No	Stainless Steel	15" Outdoor Clear Ice Machine Individual Cube, Gravity Drain	115 lbs
SIIM15-P-OD	Yes	Stainless Steel	15" Outdoor Clear Ice Machine Individual Cube, Factory Installed Drain Pump	117 lbs

Dimensions/Weight	Detail
Product Depth	23 ¼"
Product Height	34" - 35"
Product Width	14 ⅞"
Product Weight	98 lbs
Shipping Dimensions	17 ¾" x 27 ½" x 36 ¾"
Shipping Weight	117 lbs



The Legacy Companies warrants to the original purchaser of its SAPPHIRE products that they will be free from defects in materials and workmanship for the following time periods from the date of purchase shown on the sales receipt:

Two (2) Years Parts & On-Site Labor | Five (5) Years Compressor Warranty (Parts Only)

See complete warranty for details.

SapphireAppliances.com | 1.866.754.6672
The Legacy Companies
3355 Enterprise Avenue, Suite 160, Weston, FL 33331

Model	Details
Control Type	Electronic Capacitive Touch with OLED Screen
Indoor or Outdoor	Outdoor
Built-in Installation	Inset, Frameless / Overlay and Framed Cabinet Styles
Ice Size	1½" x 1½" x 1¼"
Ice Weight (g) per unit	22 g / 0.0485 lbs
Ice Quantity per cycle	24 Individual Cubes (1¼ lbs)
Ice Production Capacity	63 lbs
Ice Storage Capacity	25 lbs
Refrigerant Type	R290

Plumbing Water	Details
Water Inlet Adapter	¾" OD Compression Fitting*
Water Pressure Operating Range (psi)	20 psi – 80 psi
Water Usage	16 ½ gallons per 100 lbs of ice
Factory Installed Drain Line	10 feet
Drain Required	Yes (See manual for details)

*Water line not included

Electrical	Details
Electrical Requirements	115 V / 60 Hz
Volt Range	104 V ~ 127 V
Electrical Service	15 amp
Running Amps	2.4 amps

Approvals – Certifications	Details
ETL Sanitation	Yes
UL Residential / Commercial	Yes

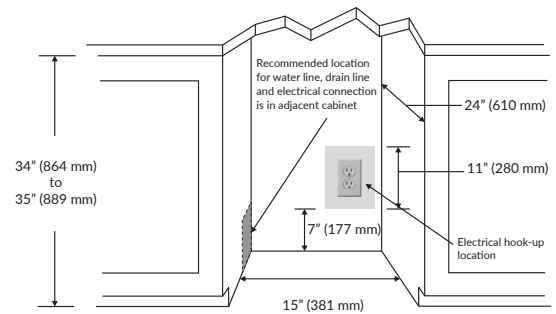

NOTE: For Gravity drain models, the drain hole cannot exceed 7 inches above the floor. For Pump models, the drain hole should be no lower than 7 inches and no higher than 4 feet above the floor.

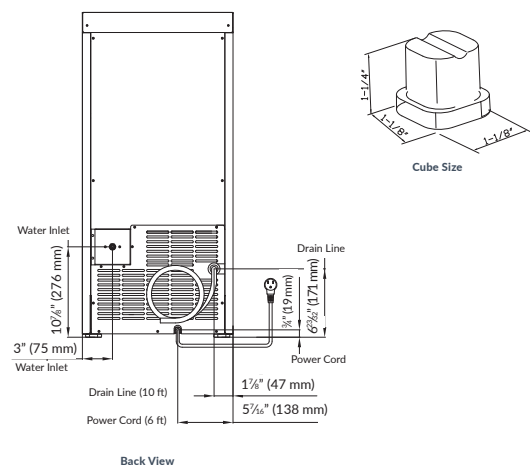
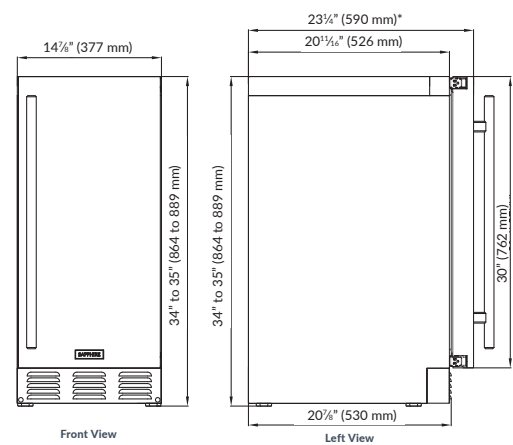

The Legacy Companies warrants to the original purchaser of its SAPPHIRE products that they will be free from defects in materials and workmanship for the following time periods from the date of purchase shown on the sales receipt:

Two (2) Years Parts & On-Site Labor | Five (5) Years Compressor Warranty (Parts Only)

See complete warranty for details.

SapphireAppliances.com | 1.866.754.6672
The Legacy Companies

3355 Enterprise Avenue, Suite 160, Weston, FL 33331