

Model	Details
Control Type	Electronic Capacitive Touch with OLED Screen
Indoor or Outdoor	Outdoor
Built-in Installation	Inset, Frameless / Overlay and Framed Cabinet Styles
Ice Size	1½" x 1½" x 1¼"
Ice Weight (g) per unit	22 g / 0.0485 lbs
Ice Quantity per cycle	24 Individual Cubes (1¼ lbs)
Ice Production Capacity	63 lbs
Ice Storage Capacity	25 lbs
Refrigerant Type	R290

Plumbing Water	Details
Water Inlet Adapter	¾" OD Compression Fitting*
Water Pressure Operating Range (psi)	20 psi – 80 psi
Water Usage	16 ½ gallons per 100 lbs of ice
Factory Installed Drain Line	10 feet
Drain Required	Yes (See manual for details)

*Water line not included

Electrical	Details
Electrical Requirements	115 V / 60 Hz
Volt Range	104 V ~ 127 V
Electrical Service	15 amp
Running Amps	2.4 amps

Approvals – Certifications	Details
ETL Sanitation	Yes
UL Residential / Commercial	Yes

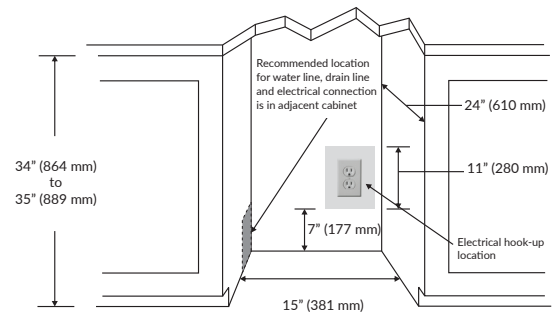

NOTE: For Gravity drain models, the drain hole cannot exceed 7 inches above the floor. For Pump models, the drain hole should be no lower than 7 inches and no higher than 4 feet above the floor.

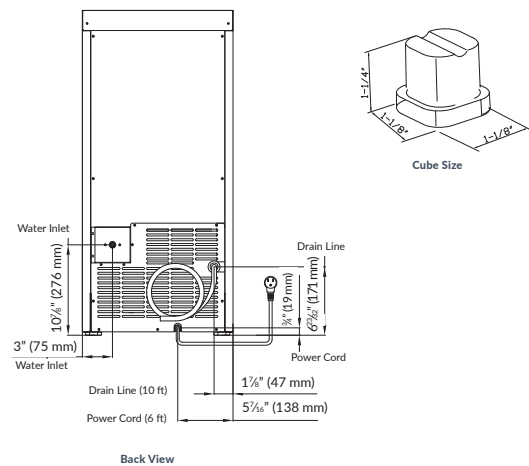
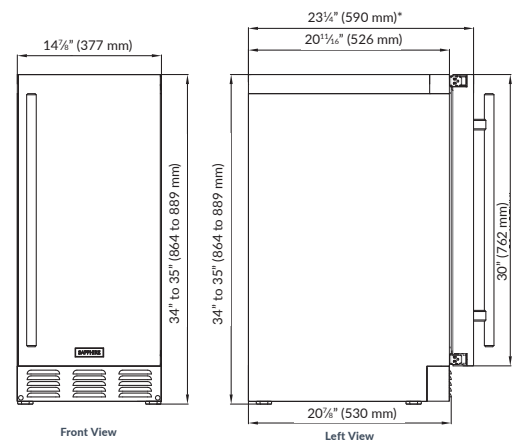

The Legacy Companies warrants to the original purchaser of its SAPPHIRE products that they will be free from defects in materials and workmanship for the following time periods from the date of purchase shown on the sales receipt:

Two (2) Years Parts & On-Site Labor | Five (5) Years Compressor Warranty (Parts Only)

See complete warranty for details.

SapphireAppliances.com | 1.866.754.6672
The Legacy Companies

3355 Enterprise Avenue, Suite 160, Weston, FL 33331