

DIN RAILS

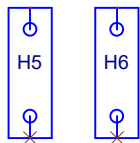

19mm STANDOFFS

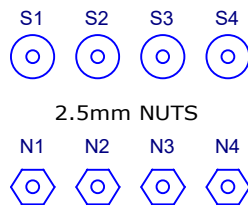

MOUNTING HOLES

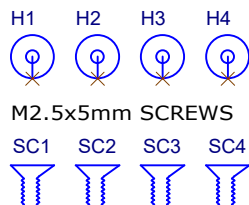

JUMPERS



SEQUENTMICROSYSTEMS.COM		
Title 3 RELAYS		
Size A	Document Number BLOCK DIAGRAM	Rev 1.0
Date: Sunday, July 31, 2022	Sheet 1	of 5

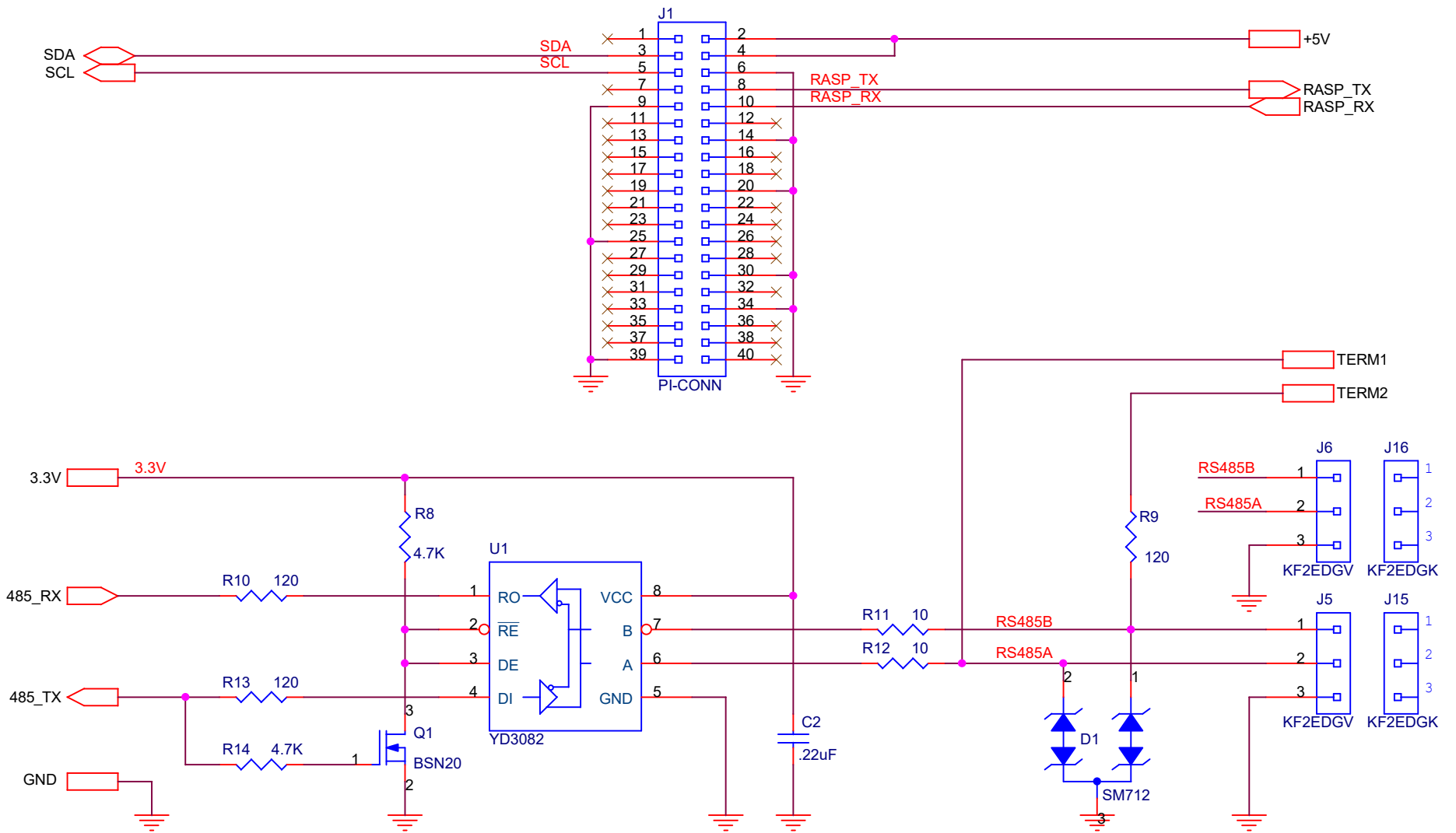

SEQUENTMICROSYSTEMS.COM		
Title		
3 RELAYS		
Size	Document Number	Rev
A	CONNECTORS	1.0
Date:	Sunday, July 31, 2022	Sheet 2 of 5

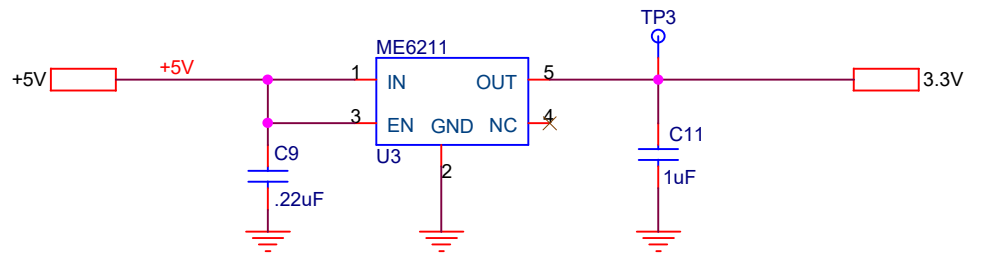
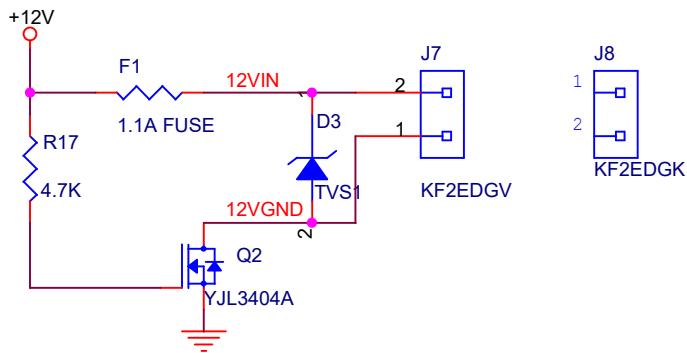
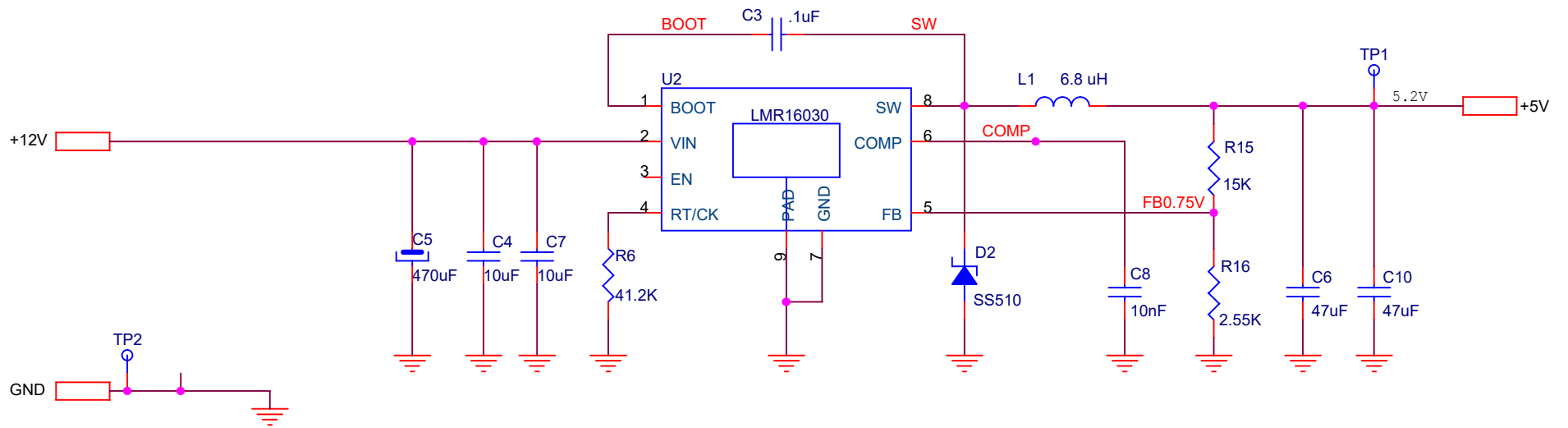

SEQUENTMICROSYSTEMS.COM		
Title		
3 RELAYS		
Size	Document Number	Rev
A	POWER SUPPLY	1.0
Date:	Sunday, July 31, 2022	Sheet 3 of 5

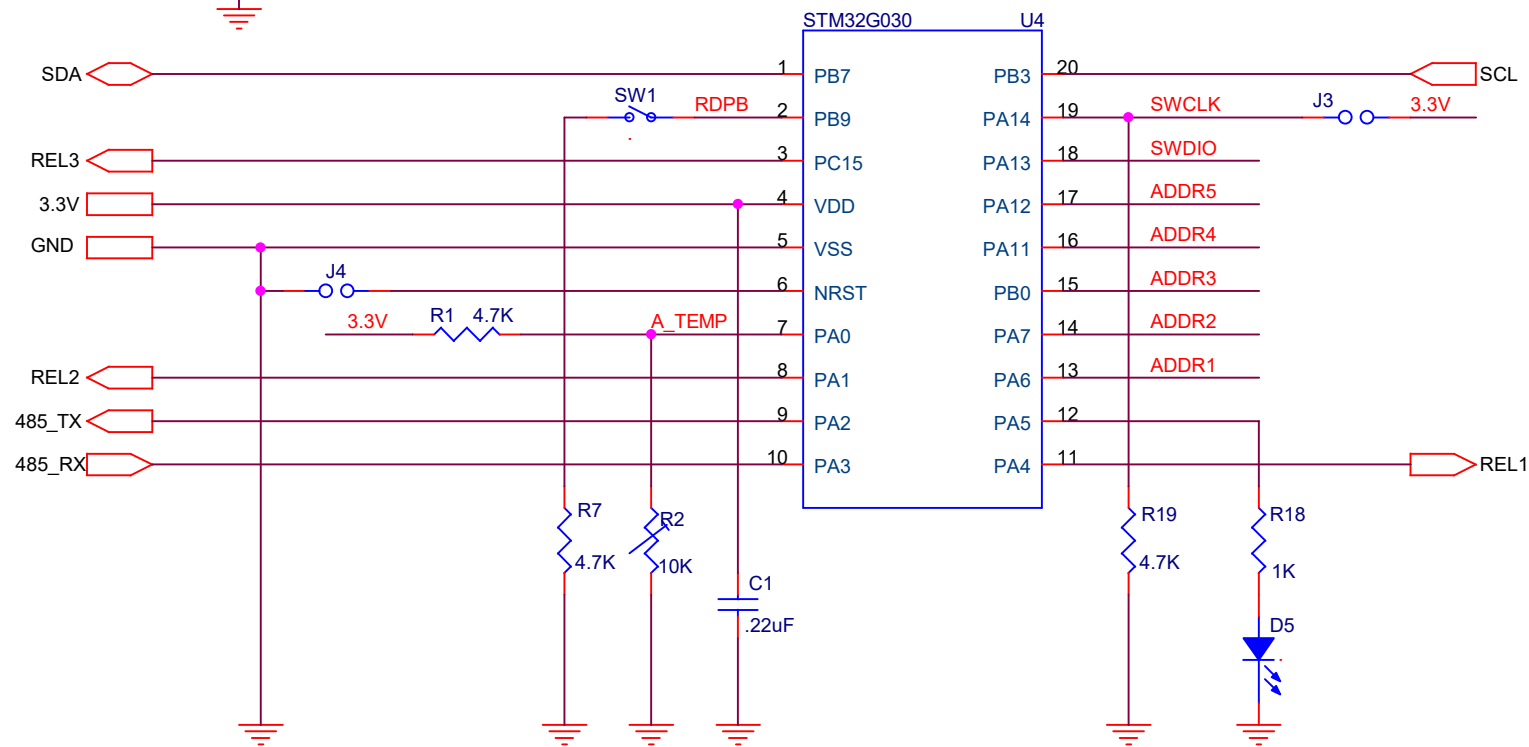
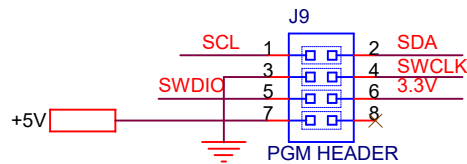
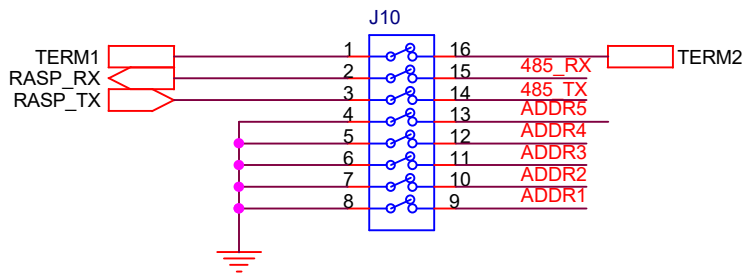

SEQUENTMICROSYSTEMS.COM		
Title		
3 RELAYS		
Size	Document Number	Rev
A	PROCESSOR	1.0
Date:	Sunday, July 31, 2022	Sheet 4 of 5

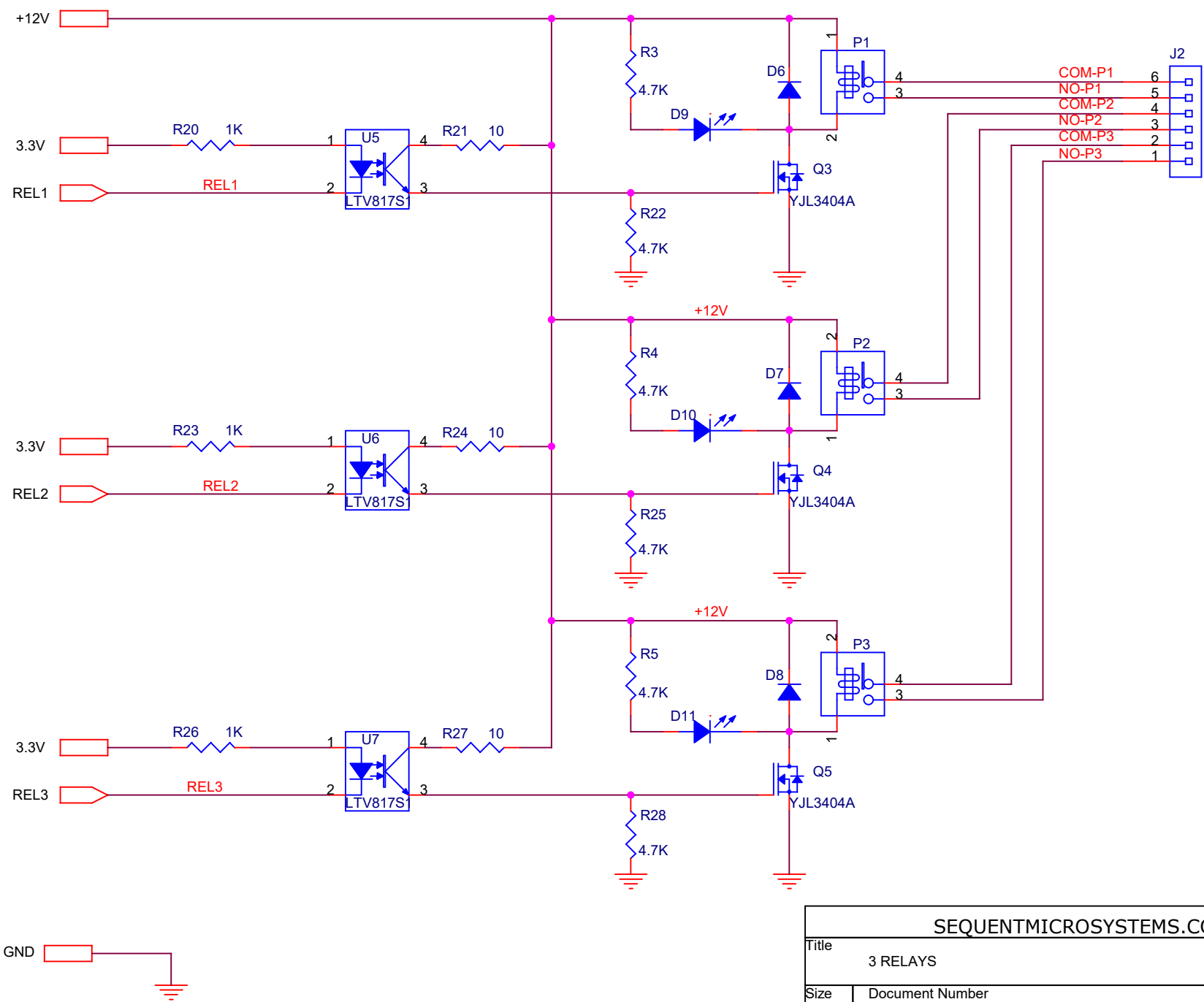

SEQUENTMICROSYSTEMS.COM		
Title		
3 RELAYS		
Size	Document Number	Rev
A	RELAYS	1.0
Date:	Sunday, July 31, 2022	Sheet 5 of 5

5 4 3 2 1

D

D

C

C

B

B

A

A

5 4 3 2 1