



Intertek

5024463

CONFORMS TO

ANSI-Z21.58

BUCK OUTDOOR GAS BURNERS

Owner's Care & Use Guide

Model BG-PB (LP or NG) & BG-SB2 (LP or NG)

DANGER - IF YOU SMELL GAS:

- 1) Shut off the gas supply to the appliance at its source.
- 2) Extinguish any open flames.
- 3) Remove burner lid to release any accumulation of gas vapor.
- 4) If a gas odor persists, keep away from your appliance and contact your gas supplier or fire department immediately.

WARNING

- 1) Do not store or use gasoline or other flammable liquids or vapor in the vicinity of this or any other appliance
- 2) An LP cylinder not connected for use shall not be stored in the vicinity of this or any other appliances.

! ATTENTION:

INSTALLER: PLEASE LEAVE THESE INSTRUCTIONS WITH THE CONSUMER.

CONSUMER: PLEASE READ & RETAIN THESE INSTRUCTIONS FOR FUTURE REFERENCE AND BEFORE INSTALLING

Contact Information
Buck Stove, New Buck Corp
200 Ethan Allen Drive, Spruce Pine NC 28777, US
828-765-6144 | www.buckstove.com

Table of Contents

Product Inspection	3
Product Specifications	4-5
Safety Information	6-9
Install & Operation Instructions	10
Gas Leak Information	11-13
Electrical Safety Warnings	14
Appliance Location & Clearances	15-16
Custom Cabinet Installation	17-20
Lighting the Burner	21-22
Flame Adjustment	23
Maintenance & Cleaning	24
LED Replacement	25
Troubleshooting Guide	26
Replacement Parts	27-30
Wiring Diagram	31
Customer Service & Warranty Information	32-33

Product Inspection



- Check to see all parts are received as per the order placed.
- Contact New Buck Corporation at 1(828)765-6144 for any missing parts.
- Inspect the products for any damages before starting the installation.
- Go through the installation instructions carefully before starting the installation.

VISIBLE LOSS OR DAMAGE

Be certain any visible damage to the carton is noted on freight bill or express receipt and signed by the person making delivery.

FILE CLAIM FOR DAMAGES IMMEDIATELY,

Regardless of extent of damage.

CONCEALED LOSS OR DAMAGE

If damage is unnoticed until the burner is unpacked, notify the transportation company or carrier immediately and file a “concealed damage” claim with them. This should be done within (5) days of the date delivery is made to you. Be sure to hold on to the container for inspection. We cannot assume responsibility for damage or loss incurred in transit.

Product Specifications

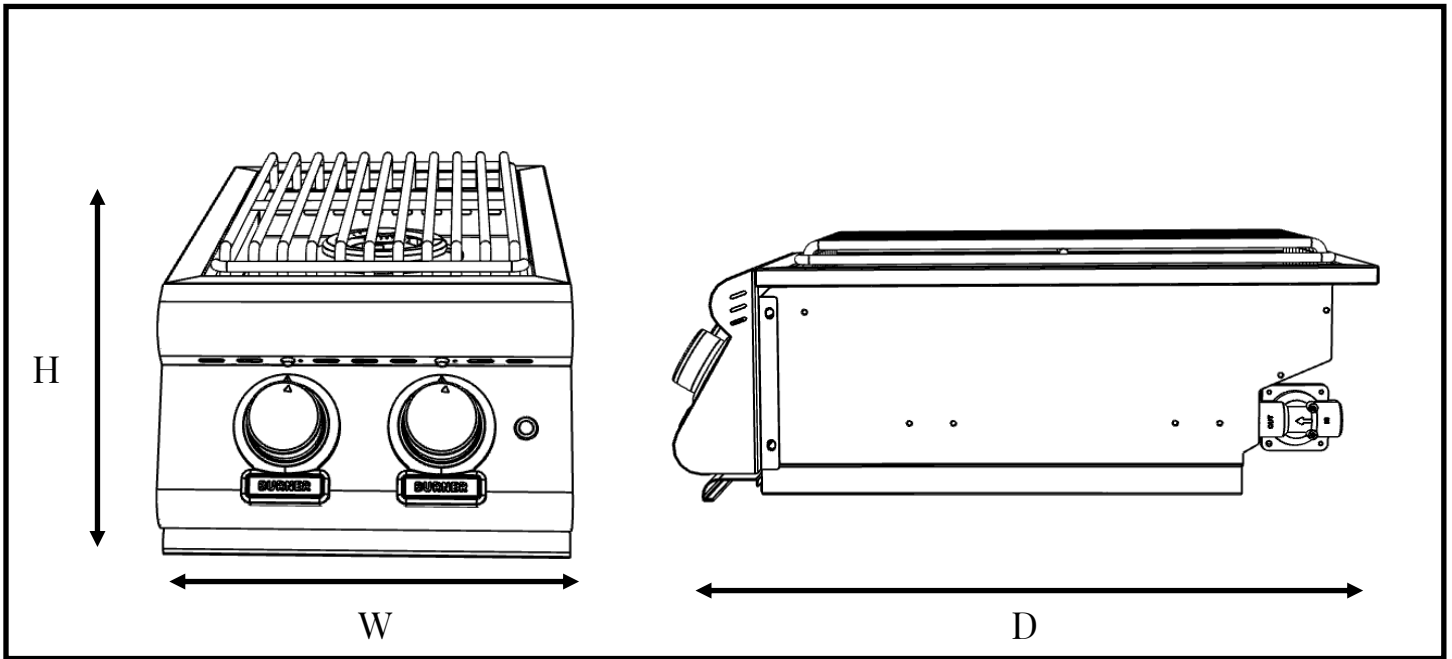

Buck Double Side Burner

Dimensions			
Width (W)	12 5/8"		
Depth (D)	25 1/4"		
Height (H)	9 1/4"		

Details

Material	Stainless Steel	Cutout Width	11 1/8"
Single Burner BTU	12,000 BTU	Cutout Depth	20 5/8"
Total Power Output	24,000 BTU	Cutout Height*	8 1/2"
Fuel Type	Natural Gas / Propane		

NOTE: ALWAYS have equipment measured by a Contractor before beginning any project.

*These dimensions create the required air gap underneath this appliance. This air gap serves multiple purposes, such as preventing a build-up of heat in the island cavity and helping provide proper airflow for combustion and/or cabinetry.

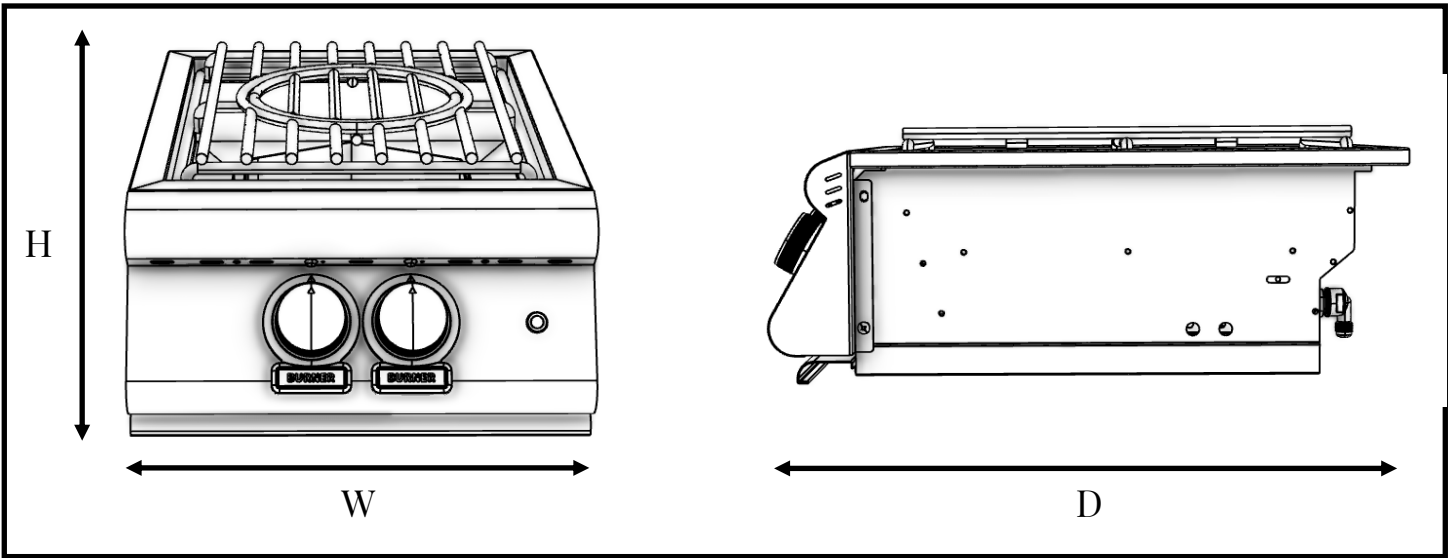

Buck Power Burner

Dimensions			
Width (W)	15 3/4"		
Depth (D)	23 1/4"		
Height (H)	9 1/8"		

Details

Material	Stainless Steel	Fuel Type	Natural Gas / Propane
Inner Burner BTU	25,000	Cutout Width	14 1/8"
Outer Burner BTU	35,000	Cutout Depth	18 7/8"
Total BTU	60,000	Cutout Height*	8 1/2"

NOTE: ALWAYS have equipment measured by a Contractor before beginning any project.

*These dimensions create the required air gap underneath this appliance. This air gap serves multiple purposes, such as preventing a build-up of heat in the island cavity and helping provide proper airflow for combustion and/or cabinetry.

Important Safety Information

WARNING

Please read this manual carefully and before using your burner to ensure proper operation, installation, servicing and to reduce the risk of fire, burn hazard and or other injury. This manual should be retained for your information

NOTE:

Improper installation and service or maintenance may cause property damage, injury or death. Do not operate this appliance without having read this manual.

All gas installations and gas conversions must be performed by a qualified technician or authorized service agent.

NOTE:

This appliance is not intended for commercial use.

FOR YOUR SAFETY!

If you smell gas:

1. Shut off gas to the appliance.
2. Extinguish any open flame.
3. If odor continues, immediately call your gas supplier or your fire department.

General Safety & Installation Warnings

Safe operation of the Buck Power/Side Burner depends upon its proper installation. Only a qualified professional installer and service technician must perform adjustments and service of the burner. Proper location and proper use is essential to insure safe and continued trouble-free operation. Any non-approved alterations made to the appliance will void the product's warranty.

NOTE:

The manufacturer cannot be held responsible for damage or injury caused by improper use of this appliance.

Please read and follow these basic precautions to ensure the proper function of the appliance and the safety of the consumer:

WARNING

To reduce the risk of fire, electric shock, or injury, read and follow these basic precautions before installing/operating your appliance.

APPLIANCE INSTALLATION

This gas appliance must be installed in accordance with all local codes.

If installation is planned in an area with no local codes, the gas appliance must be installed in accord with the National Fuel Gas Code ANSI Z223.1 and storage and handling of liquefied petroleum gases, ANSI/NFPA 58 or CSA B149.1 natural gas and propane installation code.

CALIFORNIA PROPOSITION 65 WARNING

1. This product can expose you to chemicals including Carbon Monoxide, which is a byproduct of combustion known to the State of California to cause cancer and birth defects or other reproductive harm. For more information go to www.P65Warnings.ca.gov.
2. California law requires businesses to warn customers of potential exposure to such substances. To minimize exposure to the substances, always operate this unit according to the use and care instructions found in this manual. Be certain to provide adequate ventilation when cooking.
3. Warning: Handling the brass material on this product exposes you to lead, a chemical known to the state of California to cause cancer, birth defects or other reproductive harm. (Wash hands after handling this product.)

STATE OF MASSACHUSETTS

WARNING: All gas products must be installed using a “Massachusetts” licensed plumber or gasfitter. A “T” handle type manual gas valve must be installed in the gas supply line to this appliance. This applies to permanently installed natural gas and propane installations. This does not apply to propane portable installations using a 20 pound tank.

WARNING: Improper installation, adjustment, alteration, service or maintenance can cause injury or property damage and will void your warranty. Read the installation, operating and maintenance instructions thoroughly before installing or servicing this equipment.

WARNING

EXPLOSION HAZARD!!!

Do not store flammable materials near or inside the appliance. Keep area clear and free from combustible materials, gasoline, and other flammable vapors and liquids. Failure to do so can result in death, explosion, or fire.

NOTE

Have an ABC Fire Extinguisher accessible at all times. Never attempt to extinguish a grease fire with water or other liquids.

IMPORTANT: Consult the AHJ (Authority Having Jurisdiction) or local contractor of any uncertainty.

WARNING

THIS UNIT IS FOR OUTDOOR USE ONLY!

Do not operate in a building, garage or any other enclosed areas. This could result in carbon monoxide buildup which could result in injury or death. Burners are not designed or intended for installation near a window or vent that goes into the house.

WARNING

Do not store or use gasoline or other flammable liquids or vapors in the vicinity of this or any other appliance.

The installation must conform with local codes or, in the absence of local codes, with either National Fuel Gas code, ANSI Z223.1/NFPA 54 or the National Gas and Propane installation code, CSA B149.1, or the Propane storage and Handling Code, CSA B149.2, or the Standard for Recreational Vehicles, ANSI A119.2/NFPA, and CSA Z240 RV Series, Recreational Vehicle Code as applicable.

WARNING

1. The outdoor cooking gas appliance and its individual shutoff valve must be disconnected from the gas supply piping system during any pressure testing of that system at test pressures in excess of 0.5 psi (3.5 kPa)
2. The outdoor cooking gas appliance must be isolated from the gas supply piping system by closing its individual manual shutoff valve during any pressure testing of the gas supply piping system at test pressures equal to or less than 1/2 psi (3.5kPa).

FOR YOUR SAFETY!

1. Do not store or use gasoline or other flammable vapors and liquids in the vicinity of this or any other appliance.
2. Do not store any propane/butane (G31-G30) cylinder (that is not connected for use) in the vicinity of this or any other appliance.
3. Do not attempt to heat unopened containers on the burners as pressure may build up and cause the container to explode.
4. Never use charcoal or any other solid fuel in the burners.
5. Never cook without the drip pan in place.
6. Never operate this burner while under the influence of alcohol or drugs.

NOTE: Check with City and Fire department for Local Building Codes. A Permit may be required for outdoor kitchen construction.

Please read all instructions before installing or operating your gas appliance to prevent injury and appliance damage.

- All gas appliances will get hot during use. Use extreme caution when operating the appliance.
- Do not touch hot surfaces. Always use the handle when removing the lid.
- Close supervision is necessary when this or any appliance is used near children. Keep children away from the appliance during operation and until the appliance has cooled off.
- Do not store any LP cylinder or tank not connected for use with the appliance, in the area of this appliance or any other appliance. Never store an LP cylinder or tank indoors, or within the reach of children.
- Never test the appliance for gas leaks using a lighted match or any other open flame; see leak test procedures using soap/water solutions – see section on Leak Testing.
- The use of accessories, regulators, or components not recommended by the appliance manufacturer may cause injuries and will void warranty.
- Never light the appliance without the lid removed and be certain that the burners are positioned and seated over the gas valves and on the burner support.
- Never lean over the cooking surface when lighting or operating the appliance.
- Use cooking utensils with wood handles and insulated oven mitts when operating the appliance.
- Do not store anything in the appliance. Make sure food is not forgotten in the appliance; forgotten items could melt or catch fire when the appliance is turned on.
- To prevent injuries, do not use accessories that are not recommended by the manufacturer.
- Before cleaning the appliance, "trip" the circuit breaker and disconnect the transformer.
- Never use the appliance in windy conditions. If located in a consistently windy area (oceanfront, mountaintop, etc.) a wind break will be required. Wind blowing into or across the burner, can cause poor performance and / or cause the control panel and knobs to get dangerously hot.
- Always remove the appliance lid carefully, using only the handle – the lid may be hot.
- Children should not be left alone or unattended in an area where any appliance is in use. They should never be allowed to touch, sit or stand on any part of the appliance.
- Do not store items of interest to children in cabinets above the appliance or in the appliance. Children climbing on the appliance to reach these items could be seriously injured.
- Wear proper clothing when operating this appliance. Loose-fitting or hanging garments should never be worn while using the appliance.
- Do not leave the appliance unattended while in use.
- Do not use water on grease fires! A violent steam explosion may result. Instead, smother the fire with a multipurpose ABC extinguisher.



WARNING

GAS LEAK WARNINGS

- ◆ Finding and/or fixing a gas leak is NOT a “DO-IT-YOURSELF” procedure – ONLY USE A PROFESSIONAL.
- ◆ NEVER USE THE BURNER WITHOUT FIRST LEAK TESTING THE GAS CONNECTIONS INCLUDING ALL OF THE VALVES, FITTINGS, LINES ETC. (ALL GAS CONNECTIONS SHOULD BE CHECKED)
- ◆ WARNING: DO NOT USE OPEN FLAME TO CHECK FOR LEAKS. USE OF AN OPEN FLAME COULD RESULT IN A FIRE, EXPLOSION AND BODILY HARM.
- ◆ DO NOT SMOKE WHILE PERFORMING THE LEAK TEST. Any open flame will ignite the gas.
- ◆ To prevent fire or explosion hazard, Perform leak test outdoors only.
- ◆ Check to ensure that flexible hoses do not have any cuts and wear that may affect the safety before each use. Only the factory supplied hose and regulator must be used. Use only replacement regulator and hose assemblies specified by New Buck Corporation.

Checking for Gas Leaks

Perform a leak test before each use whether the gas supply cylinder has been disconnected or not. In addition, whenever the gas cylinder is connected to the regulator or whenever any part of the gas system is disconnected or replaced, perform a leak test.

As a safety precaution, remember to always leak test your appliance outdoors in a well-ventilated area. Never smoke or permit sources of ignition in the area while doing a leak test. Do not use a flame, such as a lighted match to test for leaks. Use a solution of soapy water.

- Prepare a leak testing solution of soapy water by mixing in a spray bottle one part liquid soap to one part water.
- Make sure all the control knobs are in the OFF position.
- Turn on the gas.
 - ◇ On Natural Gas systems, turn the main feed valve to the appliance.
 - ◇ On LP systems, turn the cylinder valve knob counter clockwise one turn to open.
- Apply the leak-testing solution by spraying it on joints of the gas delivery system. This includes all valves, pipe connections, joints, lines and every point from the gas source to the burners.
- Blowing bubbles in the soap solution and/or there is a faint gas smell (Typically Gas has a rotten egg smell) indicates that a leak is present. Do not attempt to ignite the burner.
- Turn all control knobs back to the full OFF position



FOR YOUR SAFETY!



If you smell gas:

1. Shut off gas to the appliance.
2. Extinguish any open flame.
3. If odor continues, immediately call your gas supplier or your fire department.

- Stop a leak by tightening the loose joint and/or resealing with a gas approved thread sealant , removing sealant in the event of a flared connection or by replacing the faulty part with a replacement part recommended by the manufacturer. Do not attempt to repair the cylinder valve if it is damaged. The cylinder must be discarded to a proper LP tank location (company or facility) and then replaced.
- If you are unable to stop a leak turn all control knobs back to the full OFF position, shut off the gas supply to the appliance and release pressure in the hose and manifold by pushing in and turning any of the control valves one quarter turn counter-clockwise.
- On LP systems, remove the cylinder from the appliance.
- Call an authorized gas appliance service technician or an LP gas dealer.
- Do not use the appliance until the leak is corrected.
- The below diagram is intended to show what a leaking connection would look like.

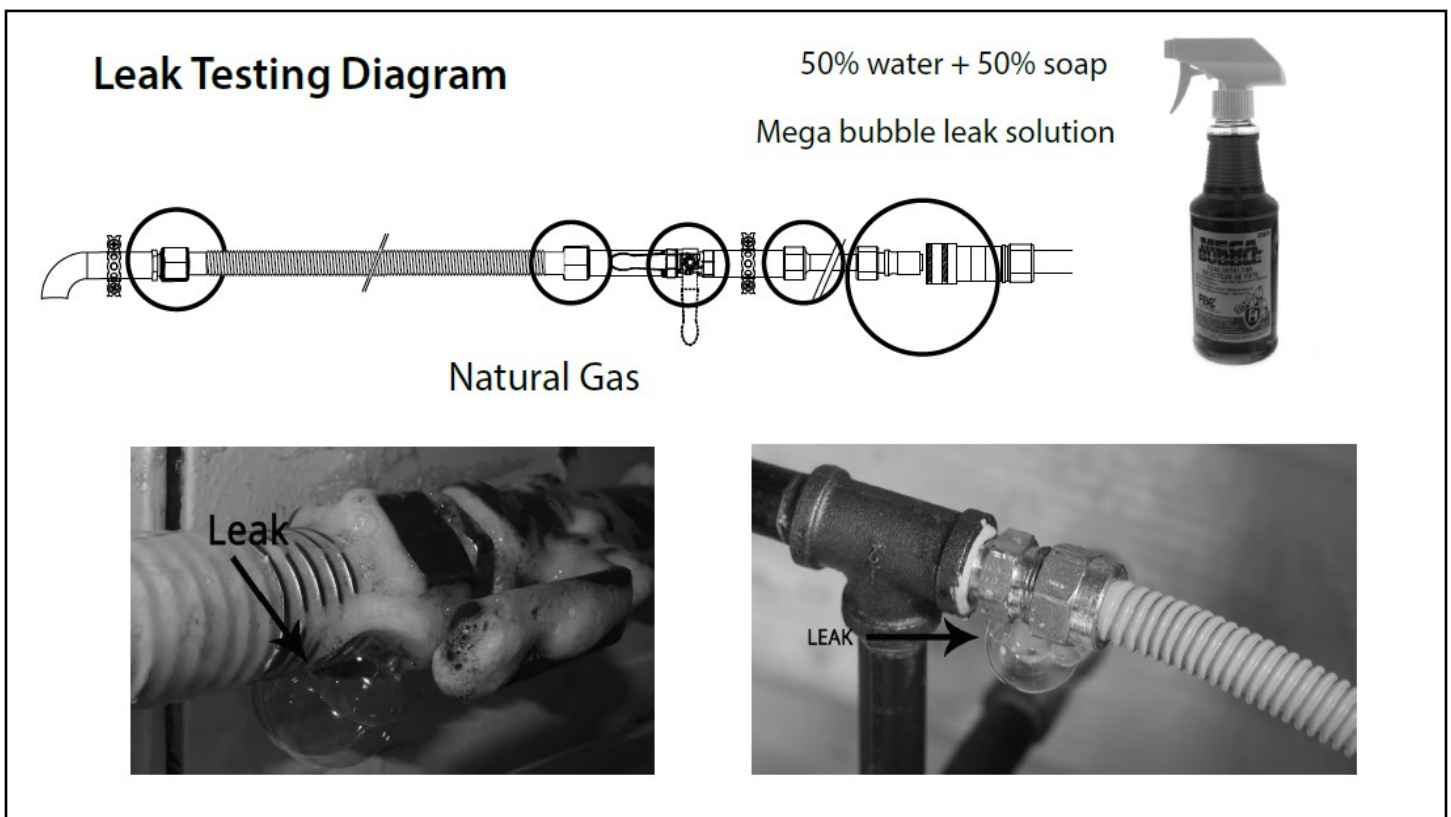

Leak Testing

- All gas piping and connections must be tested for leaks after installation or service along with before each use. This includes all valves, pipe connections, joints, lines and every point from the gas source to the burners.

All leaks must be corrected immediately. Remember-before exchanging an empty bottle for a new one; make sure all control valves are in the “off” position. This can create a low flow of gas through the burner. This would require the tank to be disconnected from the regulator, and then reconnected to reset the regulator.

Open the valve (shut-off or ‘ON’ LP tank). Test for leaks by applying liquid soap solution to all joints. Bubbles forming indicate a gas leak.



WARNING

Filling and Refilling LP Gas Cylinders:

All purging and refilling of LP Gas cylinders must be performed by qualified personnel in the LP Gas industry. Never store a spare LP Gas cylinder under or near this appliance. Never fill the LP gas cylinder beyond 80 percent full. Failure to follow these instructions may result in explosion, personal injury or death.

- Turn control knobs and cylinder valve to the OFF position. Unscrew valve.
- Remove cylinder and have it filled at your local qualified propane dealer.
- Once filled, carefully connect the valve and make sure it is secure and not leaking.
- With the control knobs in the OFF position, turn on the cylinder valve.

If you smell gas or hear a hiss of gas escaping from the tank, get away from the tank and do not attempt to correct the problem yourself. Call the Fire Department immediately.

If your appliance has no leak at the cylinder, then re-check for loose connections and retest for leaks using the method detailed in the following pages with soapy solution.

Do not subject your LP gas cylinder to excessive heat, and always store the cylinder in an upright position. Never store your LP cylinders indoors.

Make sure that when attaching components, all connections are secured and fully tightened to prevent leakage.

Always check for leaks before every use.

If one is not already available, it is required that an ON-OFF shutoff valve be installed at the gas supply source, and that the gas supply be turned off when either Natural Gas or LP Gas appliances are not in use.

Transporting and Storing LP Gas

Transport only one cylinder at a time. Ensure the cylinder is secured in an upright position with the control valve turned off and the dust cap in place. Store cylinders outdoors and out of the reach of children. Do not store cylinders in a building, garage, or any other enclosed area.

Electrical Safety and Installation Warnings

Extension cords may be used if care is exercised in their use. If an extension cord is used:

- ⇒ The marked electrical rating of the cord set or extension cord should be at least as great as the electrical rating of the appliance.
- ⇒ The cord should be arranged so that it will not touch hot surfaces, sharp edges or drape over the countertop or tabletop (where it can be pulled or tripped over unintentionally).

Outdoor extension cords should be used with products suited for outdoor use. They are surface marked with suffix letters "W" or "W-A" and with a tag stating "Suitable for Use with Outdoor Appliances".

To protect against electrical shock, the power cord and plug should be kept dry and off of the ground. Do not clean this product with water spray; do not spray cleaners into the lamp socket area.

Gasoline, lighter fluid or other flammable liquids and vapors should never be stored in the area of this appliance or any other appliance.

Before installation or service, disconnect the power supply to the work area by removing the fuse, "tripping" the circuit breaker, or unplugging the unit.

NOTE: Use a 15 AMP Breaker with GFI protection.

NOTE: This burner uses a "Transformer" to provide power to the LED lights. This diagram provides you with connection information.



Keep any electrical supply cord and fuel supply hose away from any heated surfaces, sharp edges and dripping grease.

Be certain your appliance is properly installed and grounded by a qualified technician in accordance with applicable codes. To guarantee the electrical safety of this appliance, continuity must exist between the appliance and an effective grounding system. It is imperative that this basic safety requirement be met. The manufacturer cannot be held responsible for damages caused by the lack or inadequacy of an effective grounding system.

Do not operate any appliance with a damaged power cord or power plug, and do not operate any appliance after the appliance malfunctions or has been damaged in any manner. If this should occur, return the appliance to the nearest authorized service facility for examination, repair or adjustment.

This appliance conforms to all uniform electrical safety codes and electrical grounding regulations. Install unit according to I.A.W. local codes or with National Electrical Code ANSI/NFPA 70 or CSA C22.1 in their absence.

Location of Appliance

Most importantly, this is an outdoor appliance. Ensure your appliance is positioned safely away from anything that can catch fire. *Under no circumstance is this appliance to be used indoors. This includes garages or any other enclosed area.* This outdoor cooking gas appliance is not approved to be installed in or on any recreational vehicles and /or boats. Buck burners are for single family/residential use only.

When determining a suitable location take into account concerns such as exposure to wind, proximity to traffic paths and keeping any gas supply lines as short as possible.

Do not store combustible materials, gasoline or flammable liquids or vapors around the appliance. This Buck burner must be located outdoors only. As with any gas appliance, harmful carbon monoxide is produced during the combustion process that should not be allowed to accumulate in a confined space. Please note since hot air rises above the Buck burner while in operation, covered locations should be avoided. Do not locate the Buck burner where an overhang or awning may cover it.

- DO NOT obstruct the flow of combustion and ventilation air to this appliance.
- Keep any electrical supply cords and the fuel supply hoses away from any heated surfaces and/or sharp and aggressive edges.
- Non-Combustible Enclosure: The Buck burner must be installed in a NON-COMBUSTIBLE ENCLOSURE ONLY. The determination of whether a location is combustible or non-combustible construction is made by the local fire marshal, building inspector or the local safety authority having jurisdiction.
- Clearance from Combustibles: Ensure your appliance remains at a distance of at least 14” from sides & 18” from back from any combustible material such as wood, gyprock, paper and plants. Do not store combustible materials, gasoline or flammable liquids or vapors around the appliance.
- Adequate Ventilation: Ensure there is adequate ventilation for both the appliance and/or the outdoor kitchen cavity. This is required not only for proper combustion, but also to prevent gas build up. While the amount of venting required varies on a case by case basis, consult with your local licensed professional and local code for adequate venting requirements. Keep the ventilation openings of the enclosure free and clear from any debris.
- Firm Level Surface: Use your appliance only on a firm level surface. This appliance is not designed for recreational vehicles, and should not be installed on a boat or marine craft.
- Protection from Weather: Keep the appliance protected from adverse weather, including rain and winds. Wind can back up the heat behind the control panel potentially creating a gas leak, damage to the product, and injury.
- Maintenance Access: When your appliance is installed, you should be able to access the gas supply line including the gas piping or hose, gas regulator, gas cylinder and any shut off valves. Allow clear access to the entire gas supply hose and regulator.
- Partial Enclosures: Many backyards have areas that are partially closed off, such as balconies and pergolas. In some cases, it is hard to decide whether these partially enclosed areas should be classified as indoor areas, particularly in terms of permanent (non-closable) ventilation. Consult the AHJ (Authority Having Jurisdiction) or local contractor of any uncertainty. This outdoor cooking gas appliance shall not be located under overhead construction.

CLEARANCES

TO NON-COMBUSTIBLE CONSTRUCTION

A minimum of 4" clearance from the back of the gas appliance to non-combustible construction is required.

TO COMBUSTIBLE CONSTRUCTION

This appliance should NOT be installed over, under or next to unprotected combustible construction. A minimum clearance to vertical and rear combustible material is 18" and 14" on the sides. The minimum vertical clearance to combustible materials means that ALL combustible materials must be outside this 18" zone. As an example, if you have an outdoor kitchen with a stucco or tiled surface and wood-frame construction beneath, the wood is considered combustible, even though the gas appliance is touching the stucco or tile surface, which is noncombustible. Therefore, the entire outdoor kitchen must be constructed from a non-combustible material. In extreme circumstances, the wood could potentially get hot enough to burn.

Installing Gas Appliance in Custom Built Cabinet

The installation must conform with local codes or, in the absence of local codes, with the National Fuel Gas Code, ANSI Z223.1/NFPA 54, Natural Gas and Propane Installation Code, CSA B149.1. If you are connecting an appliance to a fixed fuel piping system specifying the use of a rigid pipe, semi-rigid tubing, and/ or a connector that complies with the standard for Connectors for Outdoor Gas Appliances and Manufactured Homes, ANSI Z21.75

WARNING

ALL PARTS OF AN OUTDOOR KITCHEN MUST BE CONSTRUCTED FROM NON-COMBUSTIBLE MATERIALS.

DO NOT store or use products with flammable liquids or vapors in the vicinity of the Buck Gas appliance Cabinet, Outdoor Kitchen cabinets or any appliances.

NOTE TO INSTALLERS: All built-in appliances must use rigid pipe, semi-rigid tubing, or a connector complying with the standard for Connectors for Gas Appliances, ANSI Z21.24. CSA 6.10, or Standard for Connectors for Outdoor Gas Appliances and Manufactured homes, ANSI Z21.75. CSA 6.27, for the appliance which are connected to fixed fuel piping system (Natural Gas).

WARNING

This gas appliance is designed for non-combustible enclosures only, and must be installed and serviced by a licensed gas professional to local codes. As indicated on the rating plate, this gas appliance is designed to operate with supply pressure of 4" WC for Natural Gas & 11" WC or LP gas. For installations where the gas supply pressure exceeds these requirements, a regulator must be installed upstream of the burner's components. If the gas supply pressure is lower than these requirements, the unit will be under-fired and will not reach the maximum temperatures. Ensure that the supply line size complies with local and/ or national installation codes.

Built in Gas Appliance Dimensions

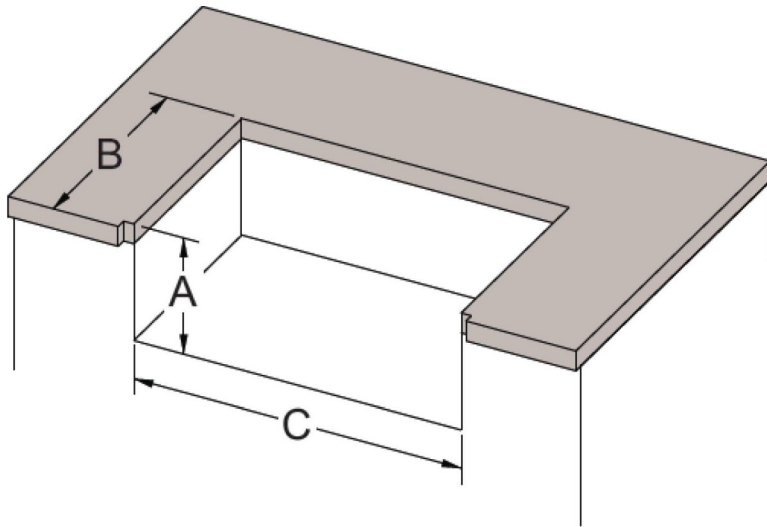

If the outdoor kitchen countertop will overhang the face of the outdoor kitchen, notching out the two front countertop edges will be necessary to allow the burner to slide flush against the outer front wall of the outdoor kitchen. Due to differing personal preferences of the size of the notch out, this is recommended to be done at the point of installation so that the consumer can dictate their preference.

Must conform with local codes or, in the absence of local codes, with either the National Fuel Gas Code, ANSI Z223.1/NFPA 54, or the Natural Gas and Propane Installation Code, CSA B149.1, or the Propane Storage and Handling Code, CSA B149.2, or the Standard for Recreational Vehicles, ANSI A119.2/NFPA 1192, and CSA Z240 RV Series, Recreational Vehicle Code, as applicable.

Cutouts		A	B	C
Double Side Burner	BG-SB2	8 1/2"	20 5/8"	11 1/8"

Double Side Burner

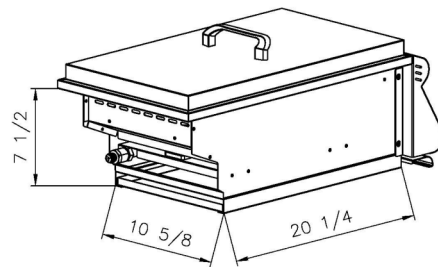
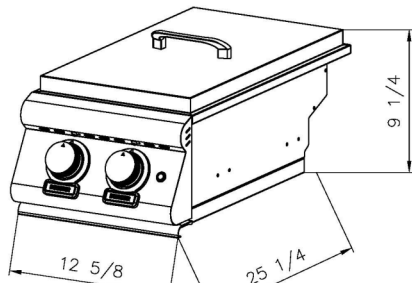

Cutouts		A	B	C
Power Burner	BG-PB	8 1/2"	18 7/8"	14 1/8"

Power Burner

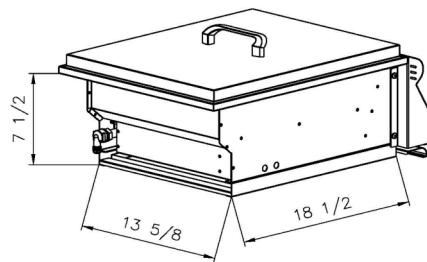
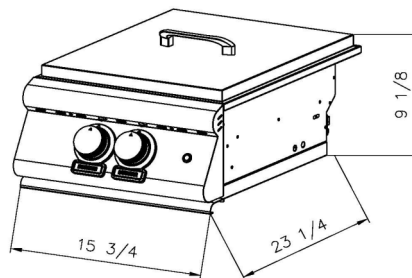

Custom Cabinet Installation Vent Locations

The following diagram shows a variety of examples of venting locations and configurations for an outdoor kitchen. These are not the only possible options for venting but instead simply some examples of the more common configurations found. Notice the middle set of vents being positioned lower on the outdoor kitchen cavity for LP gas.

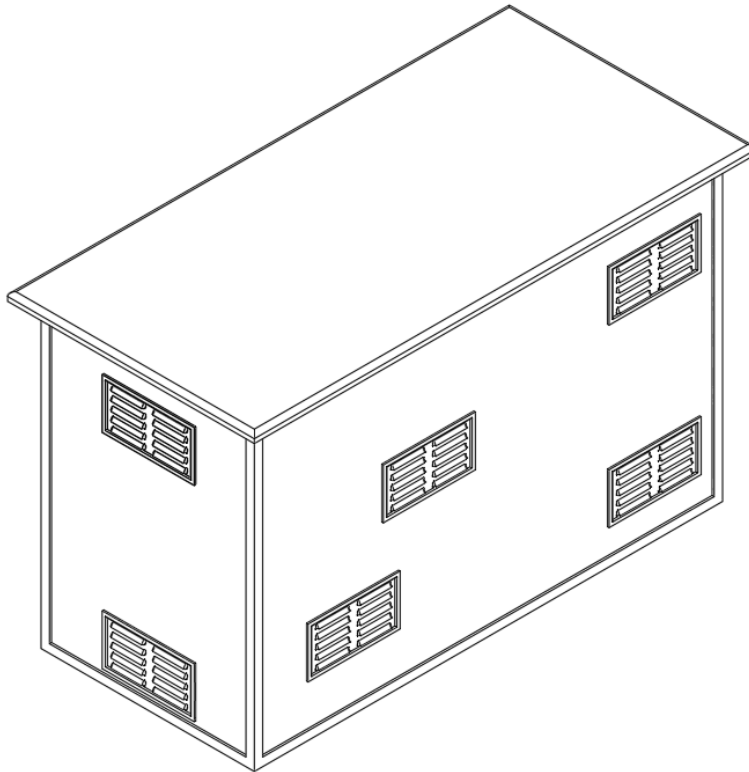

BUILDING BBQ SPECIFICATIONS

ALL GAS CONNECTION POINTS SHOULD BE TESTED FOR LEAKS AFTER INSTALLATION
PRIOR TO EACH USE OF THE GAS APPLIANCE(S).

Before installing an appliance in any outdoor kitchen cut out, make sure that the opening is not bigger than the outside frame of the appliance unit. The appliance should rest on the lip of the frame.

Pay careful attention to the location of the gas line. It should be routed away from sources of heat, sharp edges, and aggressive surfaces and should make as few bends as possible.

Ensure the gas line connection will be accessible when appliance is installed. A safety shutoff valve is required at this gas connection point

Insulated Liner Information

IMPORTANT: Before you build the frame, you must take into consideration the total weight of the sleeve, gas appliance and any finishing materials. Review the table on the next page for the proper framing dimensions for the insulation sleeve. Determine the entry point for both the gas inlet and electric connections. Make the 4" square holes for gas and electrical connections (rear or bottom access) based on your requirements. Note that the gas and electrical connections are located on the right side. A "Level" should be used to assure that the framing is level, both front to back and side to side.

NOTE: Never under any circumstance should you install the transformer or run a gas hose in between the gas appliance and the firebox!

SLEEVE INSTALLATION

Position the sleeve into the frame. No part of the combustible enclosure can protrude above the top surface or in front of the face surface of the liner.

Gas Appliance INSTALLATION

Use the proper equipment to support the gas appliance. Place the gas appliance into the sleeve and place it over the sleeve lip across the back and sides. The liner is designed to support the gas appliance without additional fasteners.

FINISHING

If desired any gap remaining between the sleeve and the combustible enclosure may be filled with a non-combustible sealant.

Insulated Liner Warning



- Never install this product into a combustible enclosure without an insulated jacket. Doing so could result in fire, property damage and personal injury.
- Never locate the gas appliance under a roof or overhang, in a building, garage, shed or other such enclosed area.
- Never locate the gas appliance under combustible construction.
- Installation must conform with local codes or, in the absence of local codes, with either the National Fuel Gas Code, ANSI Z223.1/NFPA 54, Natural Gas and propane Installation Code, CSA B149.1, or Propane Storage and Handling Code, B149.2, in Canada.

Do not store any chemicals in the outdoor kitchen. Pool chemicals or any chemical will corrode the gas hoses and manifold / valves and may cause a leak resulting in an explosion and/or bodily harm or death. Warranty on all equipment will be void if chemicals are stored in the outdoor kitchen.

Lighting The Burner

WARNING

- Always keep the lid removed when lighting the side burner.
- Never leave children unsupervised around the Gas appliances. Do not store items of interest to children around or below the side burner, or in the cabinet. Never allow children to crawl inside a cabinet or enclosure.

FOR YOUR SAFETY!

If you smell gas:

1. Shut off gas to the appliance.
2. Extinguish any open flame.
3. If odor continues, immediately call your gas supplier or your fire department.

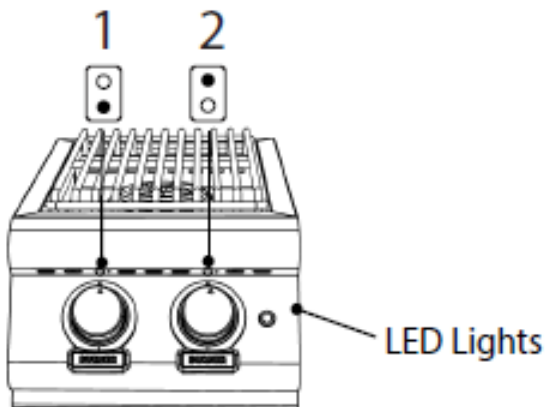

1. Front Burner | 2. Rear Burner

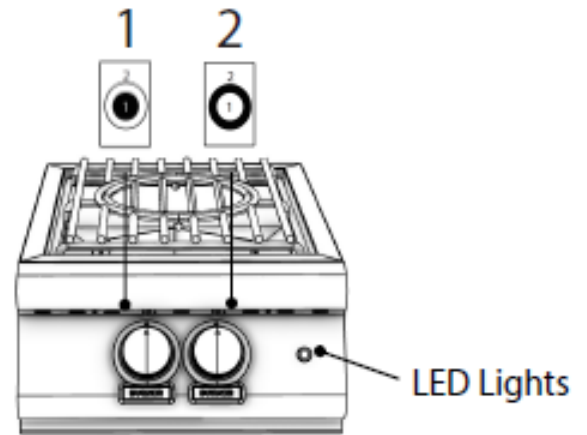

1. Inside Burner | 2. Outside Burner

Flame-Thrower Ignition

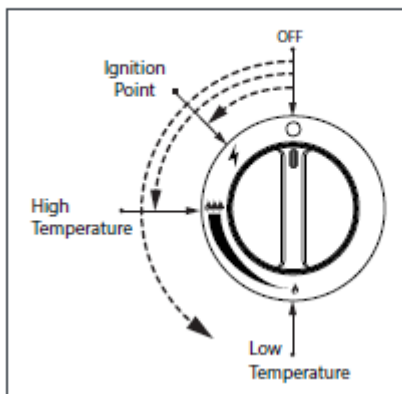

Ignition for BURNERS(1 and 2):

1. Read and complete Pre-Cooking checklist.
2. Make sure all control knobs are set to off.
3. Always light the side burner with lid open.
4. Turn fuel supply on.
5. Push in, turn the control knob counter-clockwise to the ignition point () and hold in for 5 seconds until the burners ignite. It will immediately be on high.
6. Once the burner is lit, adjust the temperature using the Max-to-Min settings.

Manually Lighting the Burner

Manual Lighting

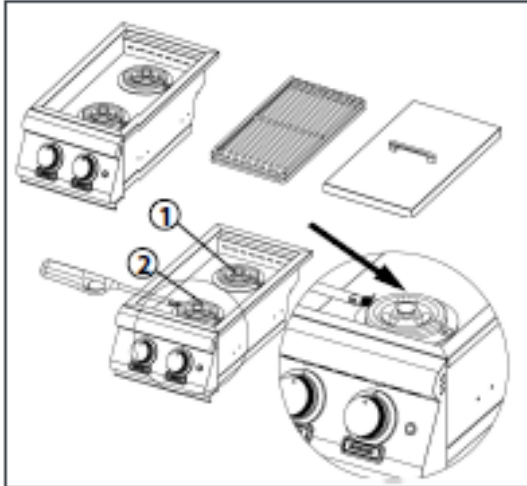

Always light the burner closest to you first in order to avoid unexpected ignition of the incorrect burner which could potentially result in injury.

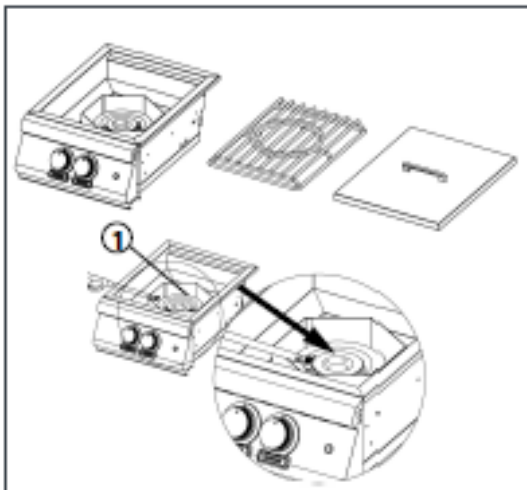

If the burners fail to light with the ignition, Follow the steps below for manual burner lighting.

1. Read and complete Pre-Cooking checklist.
2. Check for gas leaks see page 12.
3. Make sure all control knobs are set to off.
4. Always light side burner with lid removed.
5. Turn fuel supply on.
6. Place the kitchen lighter close to the holes surrounding the burner and light it up.
7. Push the left control in and turn it to HIGH to ignite the front burner. Check that the flame is lit . You should see a flame.
8. Repeat steps 6 for the other burner. If any of the burners fails to ignite during the lighting process, within three (3) seconds, stop, turn the burner control knob to OFF and wait five minutes with the lid removed and doors open to allow the gas to clear before you try again.

Flame Characteristics

⚠ CAUTION

Proper placement of each burner is critical after cleaning they must be centered on the brass orifice, resting level without any rocking. Failure to meet these conditions may cause a very dangerous condition that can cause personal injury and property damage.

Gas control knobs should be in the "OFF" position, and fuel line should be disconnected from gas valve manifold. To reduce the chance of FLASHBACK, the procedure below should be followed at least once a month or when your side burner has not been used for an extended period of time.

⚠ FOR YOUR SAFETY! ⚠

If you smell gas:

1. Shut off gas to the appliance.
2. Extinguish any open flame.
3. If odor continues, immediately call your gas supplier or your fire department.

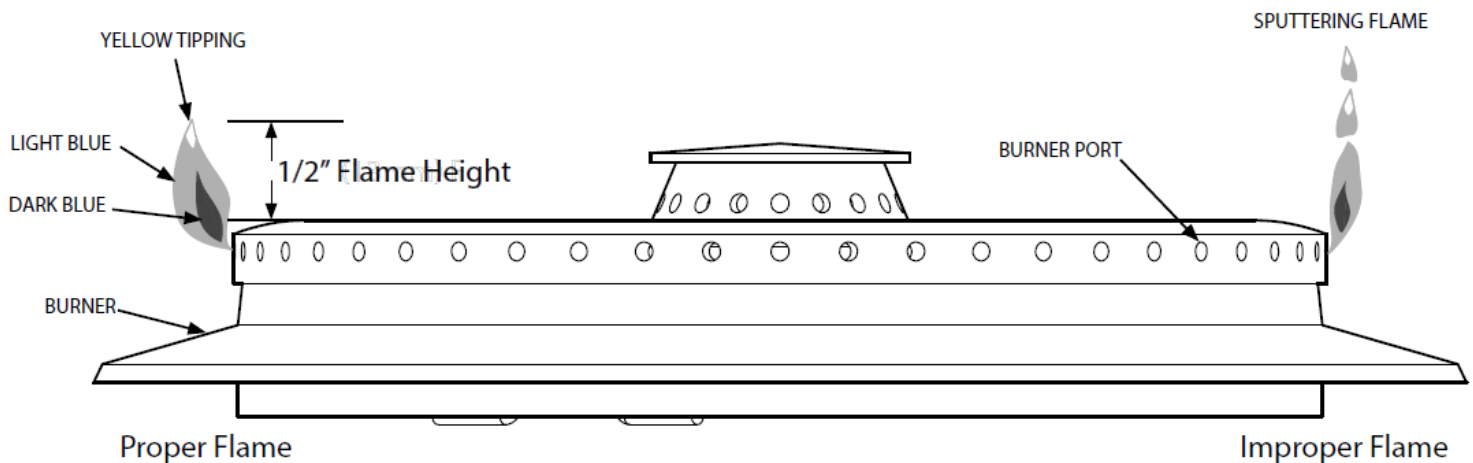

⚠ CAUTION

Turn off gas at source and disconnect the unit before servicing. To avoid the possibility of burns, maintenance should be done only when the side burner is cool. A leak test must be performed before each use and whenever any component of the gas train is replaced or gas smell is present.

Maintenance & Cleaning

The stainless steel material used in the construction of a appliance is highly rust resistant, however, chlorine in the air from swimming pools or the salt from sea air may cause surface rust to appear and even create some pitting if left on the product.

Here are a few tips to avoid this:

- Wipe down the exterior surfaces with a damp cloth after each use. Micro fiber cloths perform very well.
- Allow the surfaces to dry before installing the cover. Do not cover a damp side burner.
- In extreme environments apply a rust inhibitor which leaves a microscopic protective layer on the side burner. Products that provide a layer of vapor corrosion inhibitors (VpCI™) protect the surface very well.
- For seasonal storage use the product referred to above, ensure the side burner is dry and then cover and secure the cover to minimize the amount of damp air getting to the surfaces.

THE WARRANTY DOES NOT COVER OCCASIONAL SURFACE RUST OR STAINING DUE TO ENVIRONMENTAL CONDITIONS.

ACCESSING AND INSPECTING THE CONDITION OF THE SUPPLY HOSE

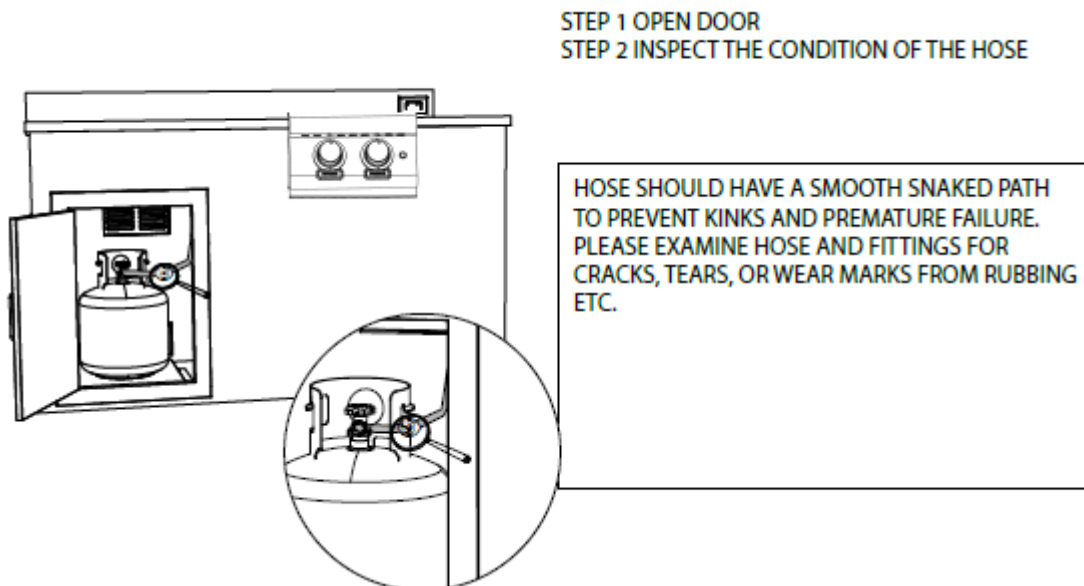

Replacing the LED Lights

⚠ NOTE

- Disconnect burner at power source before replacing lightbulbs
- The oil from your fingertips will reduce the life of the bulb. It is recommended to touch the bulb as little as possible and to wipe the bulb with a cloth after handling with bare fingers.

- 1 Remove the screw holding the LED light holder using a Phillips head screw driver.

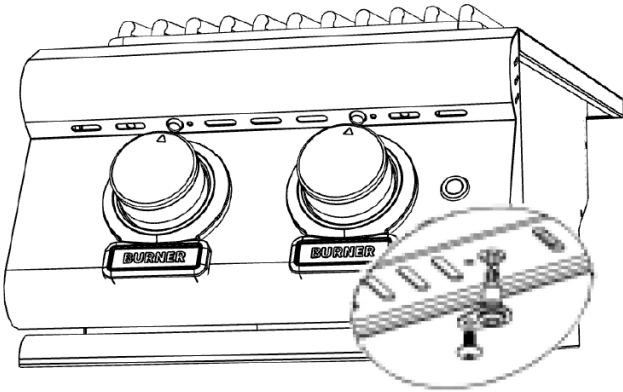

- 2 Remove the LED light assembly and disconnect it from the power connector.

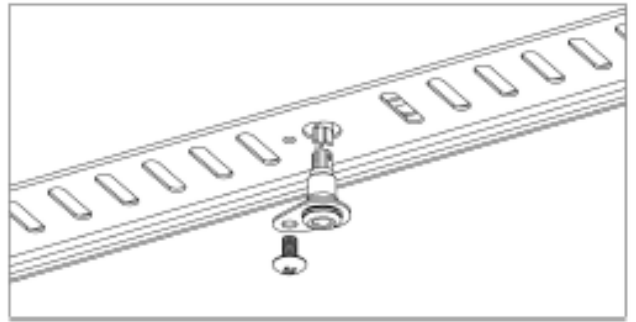

- 3 Loosen the lock nut and replace the LED

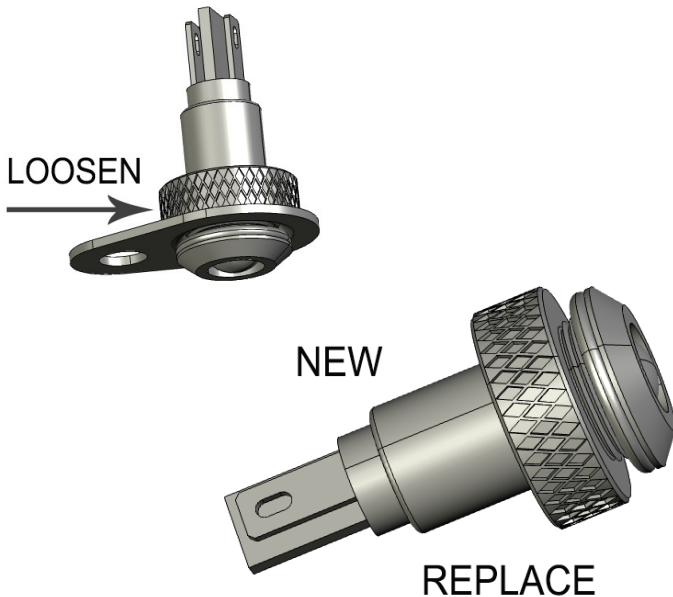

- 4

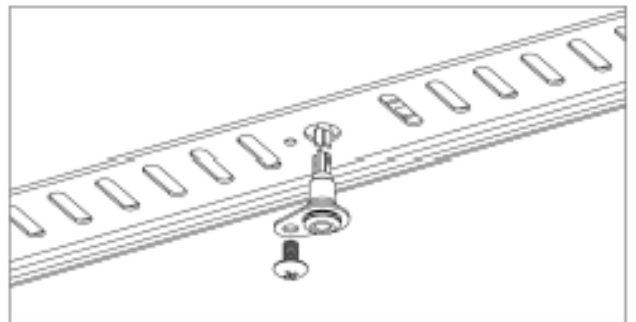

Troubleshooting

If Power or Side Burner fails to light

1. Turn off gas at source, turn control knob(s) to “OFF”, and wait five minutes with the lid removed and doors open before trying again.
2. Check gas supply/connections.
3. Repeat lighting procedure.

If the side-burner still fails to operate properly, TURN “OFF” GAS AT SOURCE, TURN CONTROL KNOBS TO “OFF”, wait for dual side burner to cool, and check the following:

Problem	Possible Causes / Correction
1. Misalignment of burner heads	Reposition burner head and make sure it sits properly on top of the burner chamber.
2. Obstruction in gas line	Consult your local gas professional.
3. Misalignment of igniter on burner	<p>Check for proper position of igniter tip. The tip of the igniter should be relatively close to the burner ports and free from grease for spark discharging. The ignition wire should be firmly connected to the valve ignition and igniter. Replace the ignition wire if the wire is broken or cracked. With gas supply closed and the control knobs set to “OFF”, check the positive igniter individually for presence of spark at igniter tip. Push the control knob in fully and rotate about 1/4 turn to the left (counter-clockwise) until click is heard; the trigger hitting the strike block should produce a blue spark at the igniter tip. Return control knob to “OFF”.</p> <p>If re-ignition is necessary - While the dual side burner is still hot, you must wait for a minimum of five minutes before commencing to re-ignite (this allows accumulated gas fumes to clear). If all checks/corrections have been made and the burner still fails to operate properly, consult your burner dealer or gas appliance service person.</p>
4.FLASHBACK	<p>When fire occurs in and around the burner tube(s), immediately turn off gas at its source and turn the control knob(s) to “OFF”. Check burners, venturi tubes, and burner ports for obstructions.</p>

Power Burner

Exploded View & Parts Breakdown

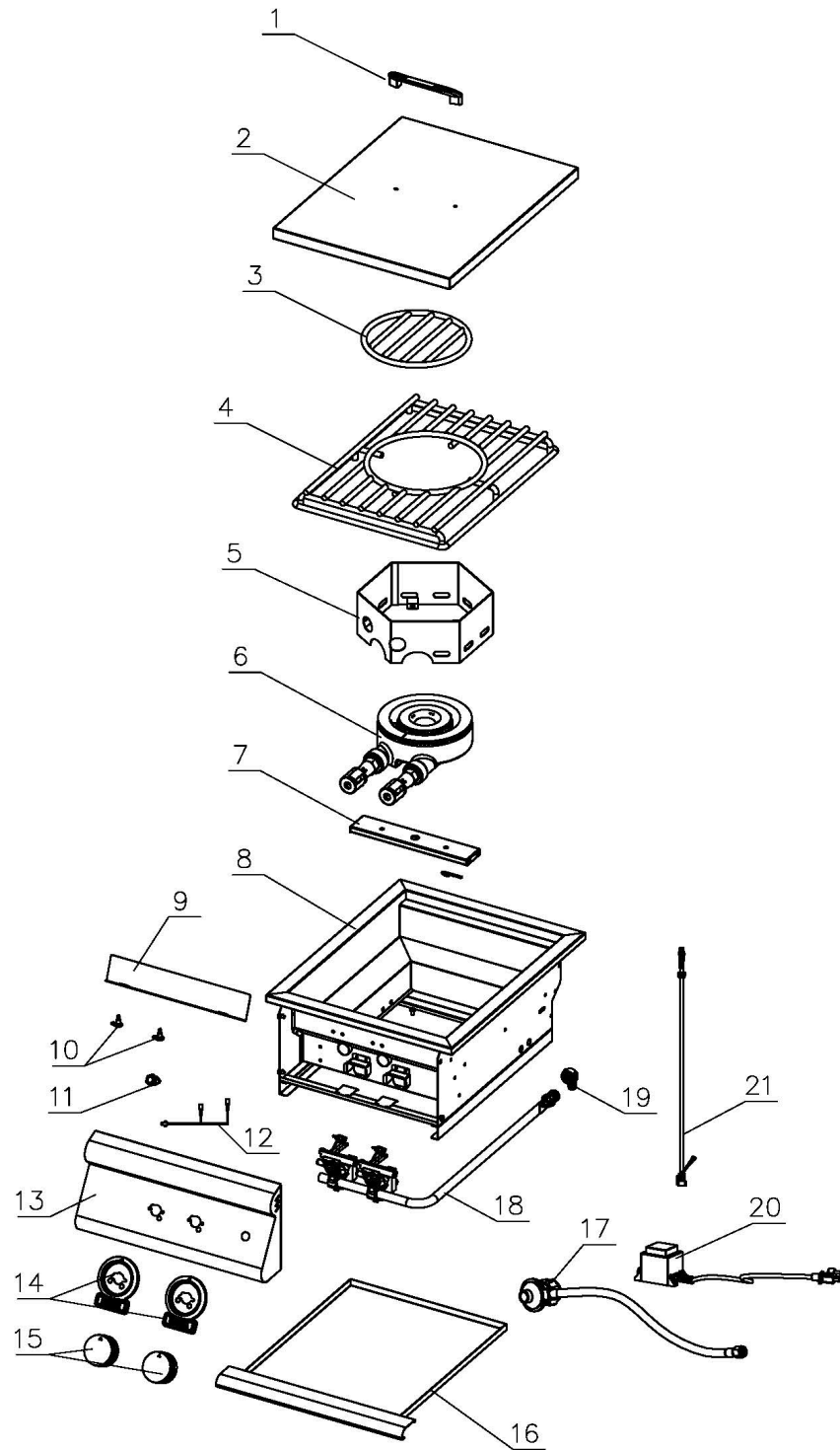

Double Side Burner

Exploded View & Parts Breakdown

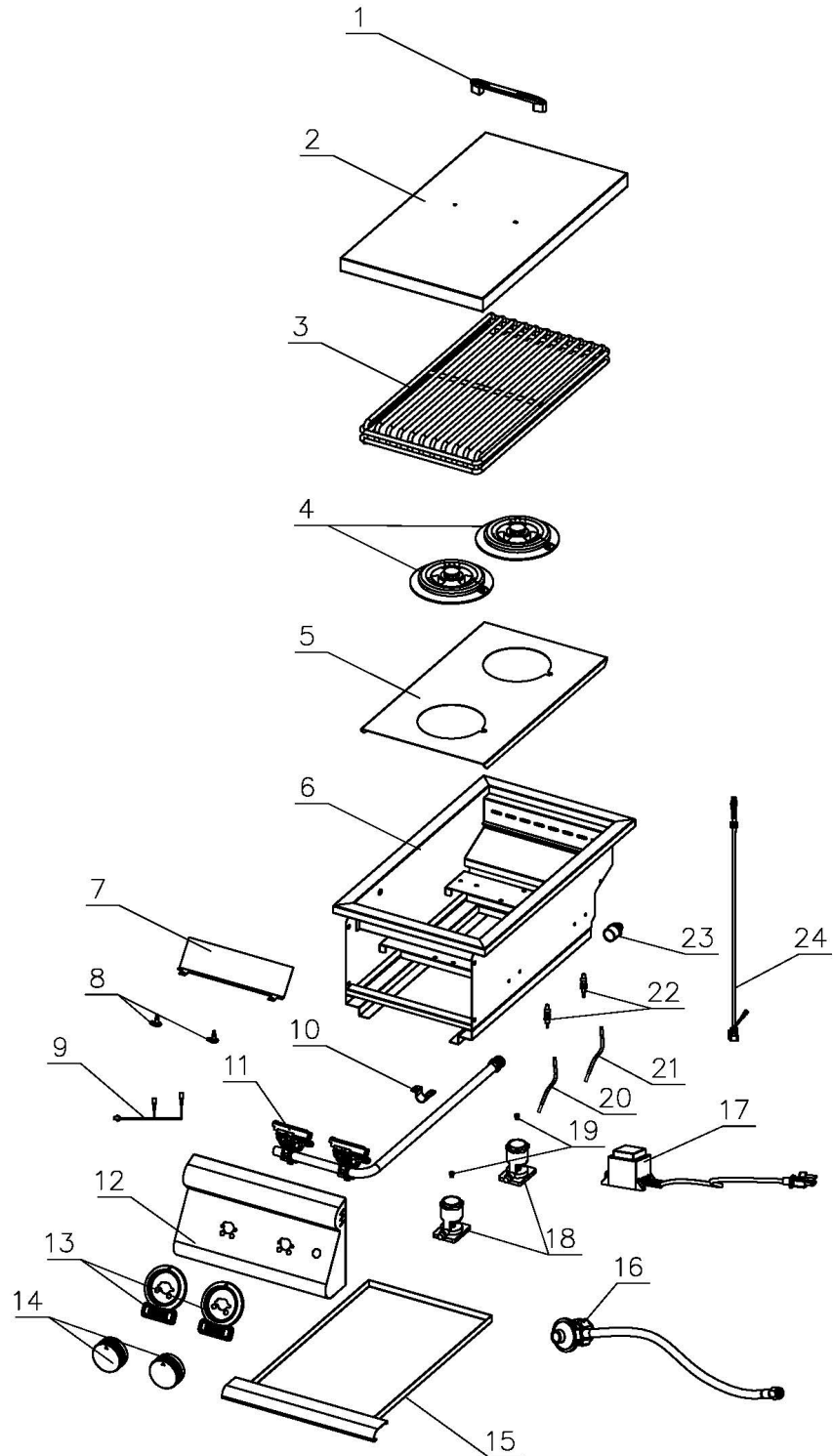

Power Burner Spare Parts List

Item #	Q'ty	Part #	Description
1	1	GP LIDHNDL	Lid Handle
2	1	GP PBLID	Lid
3	1	GP PBCOOKGRID	Cooking Grid Inner
4	1	GP PBCOOKGRIDOUT	Cooking Grid Outer
5	1	GP PBBNRSHIELD	Wind Shield
6	1	GP PBBNRASM	Burner Assembly
7	1	GP PBBRNMOUNT	Burner Fixing Plate
8	1	GP PBFIREBOX	Firebox Assembly
9	1	GP PBLEDHEATSHLD	LED Heat Shield
10	2	GP LEDBULB	LED Light
11	1	GP BTTNSWTCH	LED Switch
12	1	GP PBLEDWIRE	LED Wire
13	1	GP PBCTRLPNL	Control Panel Assembly
14	2	GP KNOBBZL	Knob Bezel
15	2	GP KNOB	Knob
16	1	GP PBDRIPTRYASM	Drip Tray Assembly
17	1	GP HOSEREG	Gas Hose Assembly
18	1	GP PBMAINVALVE	Main Valve Assembly
19	1	GP PBFITTING	Fitting
20	1	GP BNRTRNSFRM	Transformer
21	1	GP PBWIREHRNS	Wiring Harness

Double Side Burner Spare Parts List

Item #	Q'ty	Part #	Description
1	1	GP LIDHNDL	Lid Handle
2	1	GP DSBLID	Lid
3	1	GP DSBCOOKGRID	Cooking Grid
4	1	GP DSBBNRASM	Burner Assembly
5	1	GP DSBBNRMOUNT	Burner Fixing Plate
6	1	GP DSBFIREBOX	Firebox Assembly
7	1	GP DSBLEDEHEATSHLD	LED Heat Shield
8	1	GP LEDBULB	LED Light
9	1	GP DSBLEDWIRE	LED Wire
10	2	GP DSBMAINVLVFIX	Main Valve Fixing Plate
11	1	GP DSBMAINVALVE	Main Valve Assembly
12	1	GP DSBCTRLPNL	Control Panel Assembly
13	1	GP KNOBBZL	Knob Bezel
14	2	GP KNOB	Knob
15	2	GP DSBDRIPTRYASM	Drip Tray Assembly
16	1	GP HOSEREG	Gas Hose Assembly
17	1	GP BNRTRNSFRM	Transformer
18	1	GP DSBBRNHOUSE	Burner Chamber
19	1	GP DSBLPGASORIFACE	Propane Gas Oriface
20	1	GP DSBWIRESHORT	Wiring Short
21	1	GP DSBWIRELONG	Wiring Long
22	2	GP DSBIGNITER	Ignition Assembly
23	1	GP PBFITTING	Fitting
24	1	GP DSBWIREHRNS	Wiring Harness
25	1	GP FLXLINEASM	Flex Line Assembly 1
26	1	GP FLXLINEASM2	Flex Line Assembly 2

Wiring Diagram

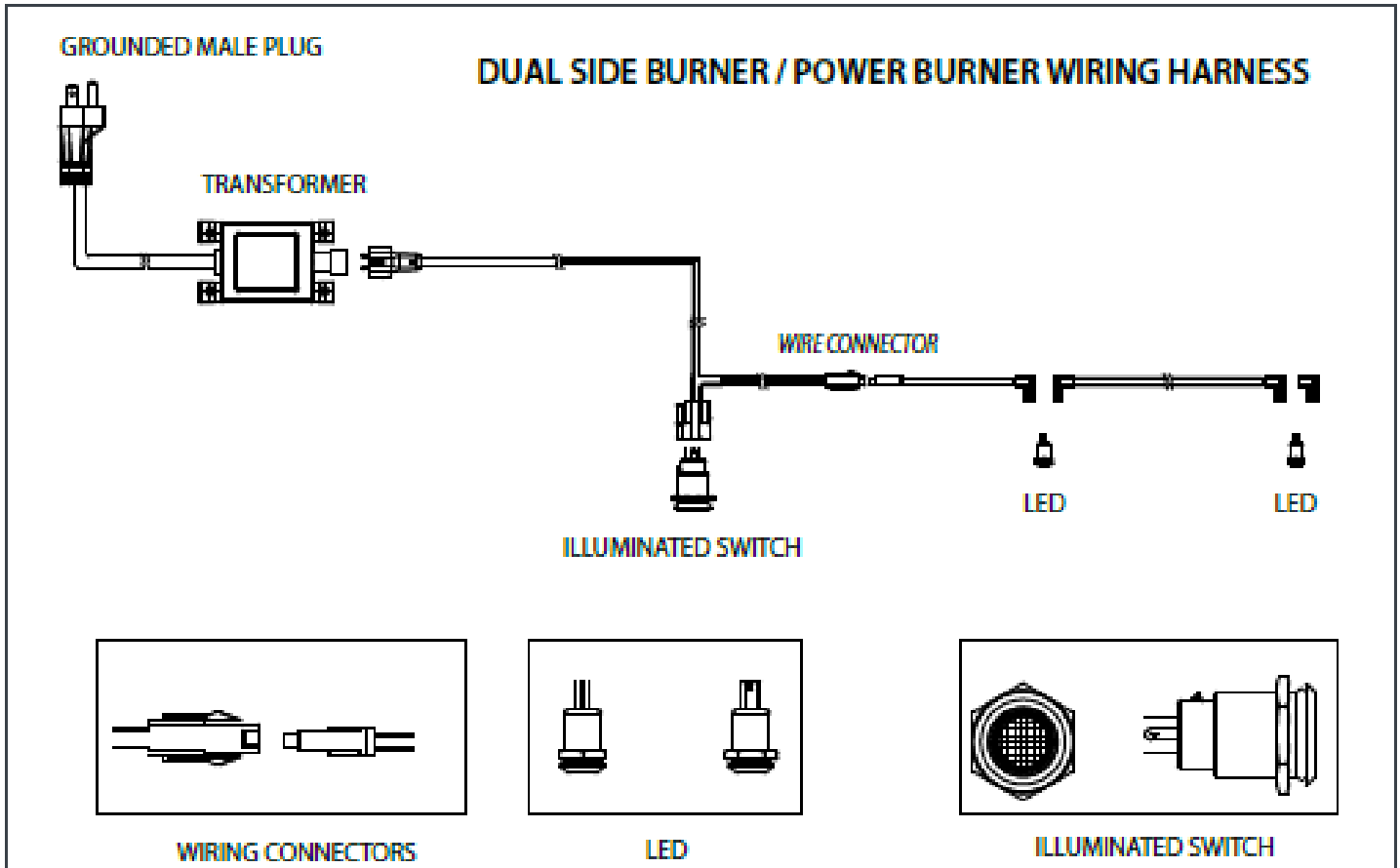

Customer Service

When contacting New Buck Corporation for customer service, please have the following information ready.

- Model number
- Date of purchase
- Proof of purchase by the original owner
- Serial Number (located on the left outside of burner.)

NEW BUCK CORPORATION (NBC)
"LIMITED WARRANTY" FOR THE POWER/SIDE BURNER
PLEASE READ THIS WARRANTY CAREFULLY
PRODUCTS COVERED

This warranty covers the Buck Outdoor Gas Side & Power Burner, so long as it is owned by the original purchaser, including optional and standard accessories purchased at the same time, subject to terms, limitations, and conditions herein set out.

This Warranty will not cover any damage and/or failure caused by abuse or improper installation of the products covered.

WARRANTY TIME PERIODS

(A) Period I For one (1) year from the date of purchase, NBC will replace or repair, at its option, any part defective in materials or workmanship. Only the cost of parts are included. The customer pays any labor or transportation charges required.

Thereafter,

(B) Period II For the period after the first year from the date of purchase and extending for five (5) years as long as the Power / Side Burner is owned by the original purchaser, NBC will repair or replace, at its option, any part defective in materials or workmanship, with the exception of: wiring, switches, components, optional and standard accessories and all parts not permanently attached to the burner unit. Parts not permanently attached to the burner unit are defined as those items designed to be removed from the burner, including those removable with common hand tools. The costs of parts only are included. The customer pays any labor or transportation charges required.

PROCEDURE

Should you feel that your Power/Side Burner is defective, you should contact any NBC authorized dealer for the name of your nearest authorized NBC service representative, who will instruct you on the proper procedure, depending on which Warranty Time Period (Period I or Period II) applies.

If for any reason you are dissatisfied with the suggested procedures, you may contact us in writing at:

New Buck Corporation
Customer Service Department
P. O. Box 69
Spruce Pine, NC 28777
Email: info@buckstove.com

CONDITIONS AND EXCLUSIONS

- (A) Replacement of parts may be in the form of new or fully reconditioned parts, at NBC's option.
- (B) There is no other express warranty. All implied warranties of merchantability and fitness for use are limited to the duration of the Express Warranty.
- (C) New Buck Corporation is not liable for indirect, incidental, or consequential damages in connection with the use of the product including any cost or expense of providing substitute equipment or service during periods of malfunction or non-use. Some states do not allow the exclusion of incidental or consequential damages, so the above exclusion may not apply to you.
- (D) All warranty repairs under this warranty must be performed by an authorized Buck Stove service representative. Repairs or attempted repairs by anyone other than an authorized service representative are not covered under this warranty. In addition, these unauthorized repairs may result in additional malfunctions, the correction of which is not covered by warranty.

OTHER RIGHTS

This warranty gives you specific legal rights, and you may also have other rights, which vary from state to state.

OWNER REGISTRATION CARD

The attached Owner Registration Card must be completed in its entirety and mailed within 30 days from the date of purchase or from the date of installation, if installed by a factory certified installer, to New Buck Corporation in order for warranty coverage to begin.

PLEASE NOTE: The Owner Registration Card must contain the Authorized NBC Dealer Code Number and the Certified Installer's number (if applicable) for warranty coverage to begin.

To be completed by selling distributor/ dealer/ customer:

Name

(Last) (First)

Address

City _____ State _____ Zip _____

CUSTOMER EMAIL: _____

Burner—Serial Number _____

Date of Installation: Day _____ Month _____ Year _____

Installer's Name _____

Installer's Certification Number _____

Dealer's Name _____

City _____ State _____ Zip _____