

No.	PARTS NAME	MATERIAL	NOTES	QTY
①	CONVERSION BRACKET	STEEL PAINTED BLACK	2-M8 NUT WELDING	2
②	BOLT	Cr3 M8x16	with WASHER, SPRING WASHER	4

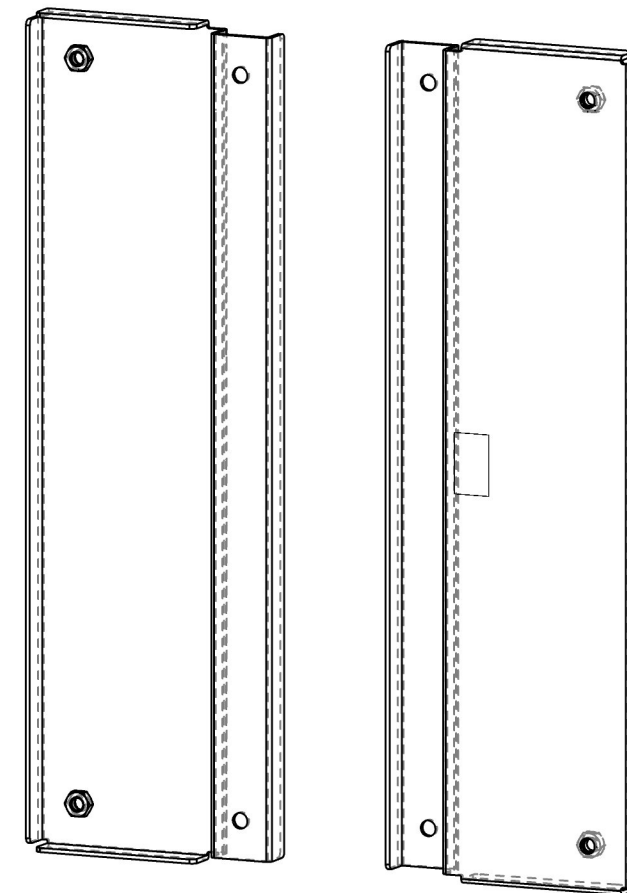
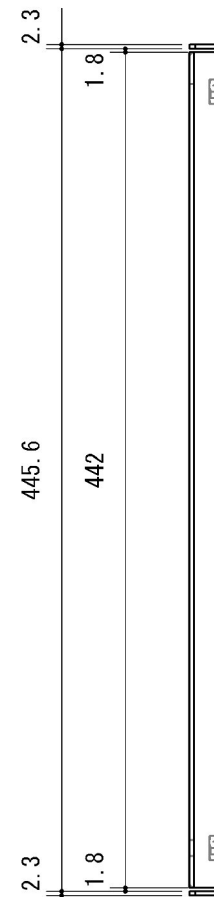
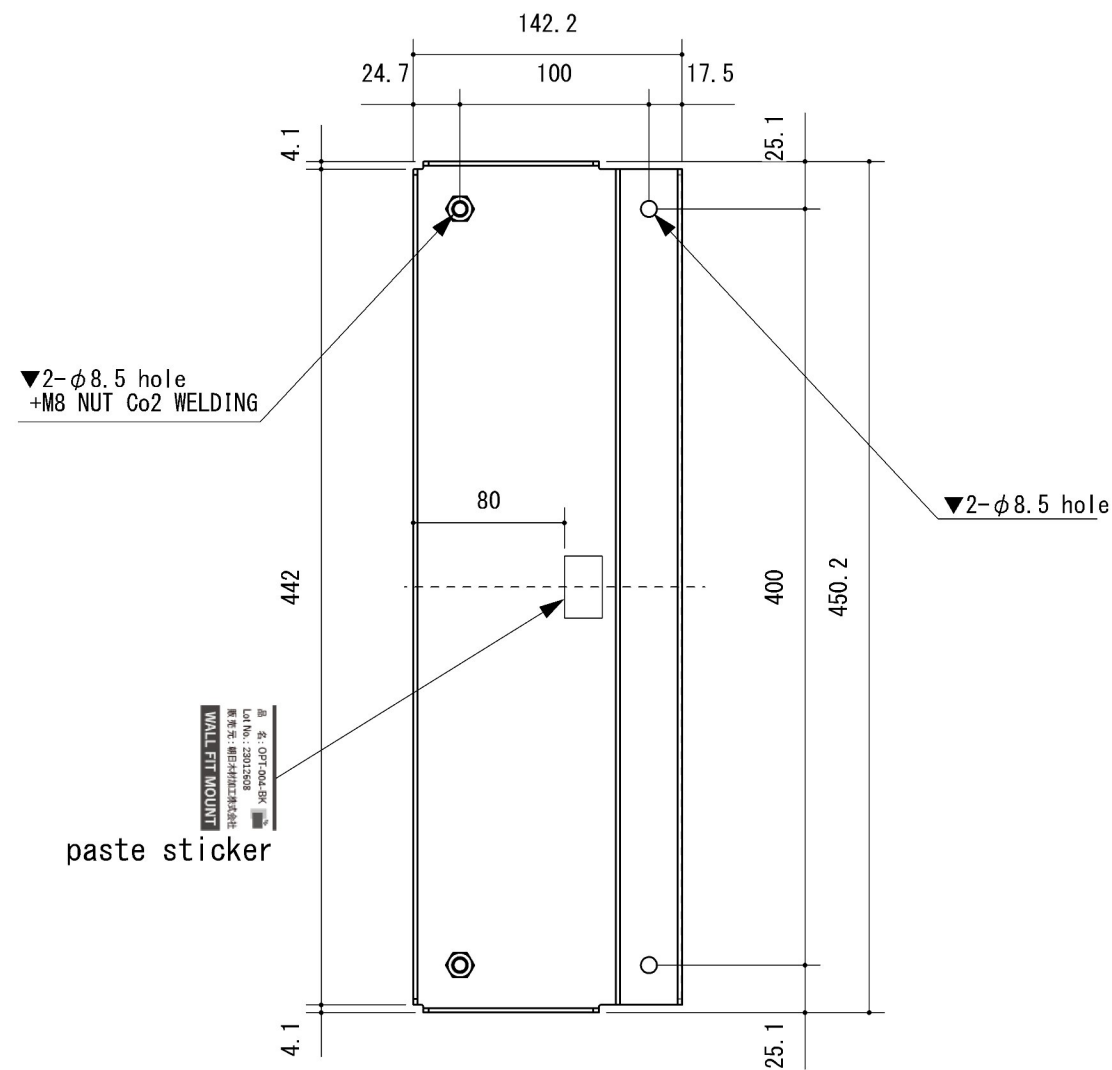
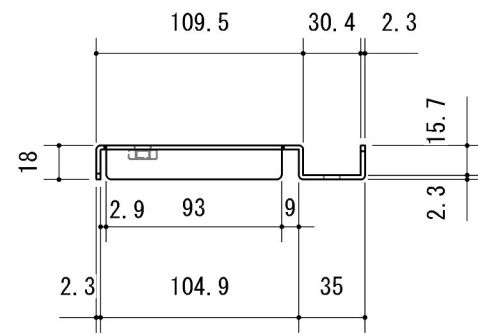

NOTE) RoHS Compliance
 NOTE) WITHOUT BURR, SHARP-EDGES, RUST.
 NOTE) PAINTING COLOR : BLACK
 ref. Painting color sample.

MARK	ALTERATION CONTENTS	ALTERATION DATE	DRAWN BY
△ X			
△ X			
△ X			
△ X			
△ X			

DATE: 2023.01.26

STAMP		承認 APPROVED BY		検図 CONFIRMED BY		担当 PLANNED BY		製図 DRAWN BY		部品名称 TITLE	
										ASSEMBLE DRAWING	
										型名 MODEL No.	
										OPT-004-BK	
		単位 UNIT		尺度 SCALE		個数 QTY		図番 DRAWING NO.			
		mm		1/4							