



ELECTRIC TANKLESS WATER HEATER - POINT OF USE

INSTANT-FLOW® C-MICRO - LOW ACTIVATION

APPLICATION: commercial, industrial, residential, public lavatories, kitchen/bar sink

PRODUCT FEATURES

- Uses a digital microprocessor for temperature control, Ultra quick response times for temperature variations - 120 times per second. Microprocessor use is the most energy efficient means of heating water
- Unlimited hot water
- Ideal for sensor /hands-free faucets with the 104°F (40°C) factory preset setting; no mixing valve needed
- Ultra Low Flow Activation - 0.20 GPM (0.75 LPM)
- Saves water and energy - 99% energy efficient
- Meet all CAL GREEN low flow requirements
- Meets LEED v4 low flow requirements
- Vandal resistant rugged cast aluminum housing
- Space saving compact size: 6-1/4" (H) x 9-5/8" x 2-3/4" (159 (H) x 244 x 70mm)
- Meets applicable building codes including ADA, UL, IAPMO, UPC, CSA.
- Environmentally friendly
- Made in the U.S.A.
- Patent Pending
- Field Adjustable Temperature 104-125°F (40-52°C) (Option -ADJ)

Chronomite Instant-Flow® C-Micro - Low Activation models are manufactured to provide reliable point-of-use hot water. There is no pressure and temperature relief valve needed (unless required by code), saving time and money on installation.

Housing is fabricated from rugged cast aluminum alloy.

Element assembly is fabricated from Celcon plastic.

Heating coils are nichrome.

Faucet flow controls are supplied with each unit. 3/8" compression fittings are supplied (standard). Optional 1/2" male NPT water connections available.



Instant-Flow® C - Micro - Low Activation

GUIDE SPECIFICATION

Tankless Water Heater shall be a Chronomite Laboratories Model

CM - L / VOLTS OPTIONS

AMPS

with and

to heat to a preset temperature of:

- 104°F (40°C) 110°F (43°C) Other temperature settings available upon request (specify below)
- 120°F (49°C) (Meets health code)

Unit shall be provided with Celcon waterways, and Nichrome heating coils. Temperature controlled by microprocessor.

OPTIONS

- PA 765 ABS Housing (P)
- Satin Finish Stainless Steel Housing (SS)
- High Polish Finish Stainless Steel (SSP)
- Pressure & Temp Relief Valve Assembly (TP)
- 1/2" Male NPT (NPT08)
- Field Adjustable Temperature (ADJ)
- Disconnect Switch, Rotary 40A - Lockable Nema 4X (2095-1)



Member of U.S. Green Building Council



Water Conserving Product



Made in the USA

Complies with Standards for:

LISTED TO: UL STD 499

CERTIFIED TO: CAN/CSA STD C22.2 No. 98



Federal Public Law 111-380 (No Lead)

Intertek 5001365 CALGreen

CHRONOMITE LABORATORIES, INC.

17451 Hurley St. :: City of Industry, CA 91744
 Phone 800-447-4962 :: 626-937-4270
 Fax 626-937-4279 :: www.chronomite.com

MEMBER OF





ELECTRIC TANKLESS WATER HEATER - POINT OF USE

INSTANT-FLOW® C-MICRO - LOW ACTIVATION

For the model being selected, please place the corresponding amps and volts values in the Guide Specifications on the first page.

MODEL	AMPS	VOLTS	90°C WIRE	WATTS	ACTIVATION GPM	°F TEMPERATURE RISE @				
						0.35 GPM	0.50 GPM	1.00 GPM	1.50 GPM	2.00 GPM
CM-12L/120	12	120	14 AWG	1440	0.20	28	20	---	---	---
CM-12L/208	12	208	14 AWG	2500	0.20	49	34	---	---	---
CM-12L/240	12	240	14 AWG	2880	0.20	56	39	20	---	---
CM-12L/277	12	277	14 AWG	3320	0.20	65	45	23	---	---
CM-15L/120	15	120	14 AWG	1800	0.20	35	25	---	---	---
CM-15L/208	15	208	14 AWG	3120	0.20	61	43	21	---	---
CM-15L/240	15	240	14 AWG	3600	0.20	70	49	25	---	---
CM-15L/277	15	277	14 AWG	4150	0.20	81	57	28	---	---
CM-20L/120	20	120	12 AWG	2400	0.20	47	33	---	---	---
CM-20L/208	20	208	12 AWG	4160	0.20	81	57	28	---	---
CM-20L/240	20	240	12 AWG	4800	0.20	90+	66	33	22	---
CM-20L/277	20	277	12 AWG	5540	0.20	90+	76	38	25	---
CM-30L/120	30	120	10 AWG	3600	0.20	70	49	25	16	---
CM-30L/208	30	208	10 AWG	6240	0.20	90+	85	43	28	21
CM-30L/240	30	240	10 AWG	7200	0.20	90+	90+	49	33	25
CM-30L/277	30	277	10 AWG	8310	0.20	90+	90+	57	38	28
CM-40L/208	40	208	8 AWG	8320	0.20	90+	90+	57	38	28
CM-40L/240	40	240	8 AWG	9600	0.20	90+	90+	66	44	33

Note 1: Maximum temperature rise may be governed by preset outlet temperature.

Note 2: Local plumbing and electrical codes must be followed for installation of water heater and the accessories.

INSTANT-FLOW® C-MICRO - LOW ACTIVATION METRIC CHART

MODEL	AMPS	VOLTS	90°C WIRE	WATTS	ACTIVATION LPM	°C TEMPERATURE RISE @				
						1.30 LPM	2.00 LPM	4.00 LPM	6.00 GPM	8.00 LPM
CM-12L/120	12	120	14 AWG	1440	0.75	16	10	---	---	---
CM-12L/208	12	208	14 AWG	2500	0.75	28	18	---	---	---
CM-12L/240	12	240	14 AWG	2880	0.75	32	21	10	---	---
CM-12L/277	12	277	14 AWG	3320	0.75	37	24	12	---	---
CM-15L/120	15	120	14 AWG	1800	0.75	20	13	---	---	---
CM-15L/208	15	208	14 AWG	3120	0.75	34	22	11	---	---
CM-15L/240	15	240	14 AWG	3600	0.75	40	26	13	---	---
CM-15L/277	15	277	14 AWG	4150	0.75	46	30	15	10	---
CM-20L/120	20	120	12 AWG	2400	0.75	27	17	---	---	---
CM-20L/208	20	208	12 AWG	4160	0.75	46	30	15	10	---
CM-20L/240	20	240	12 AWG	4800	0.75	50+	34	17	11	---
CM-20L/277	20	277	12 AWG	5540	0.75	50+	40	20	13	10
CM-30L/120	30	120	10 AWG	3600	0.75	40	26	13	---	---
CM-30L/208	30	208	10 AWG	6240	0.75	50+	45	22	15	11
CM-30L/240	30	240	10 AWG	7200	0.75	50+	50+	26	17	13
CM-30L/277	30	277	10 AWG	8310	0.75	50+	50+	30	20	15
CM-40L/208	40	208	8 AWG	8320	0.75	50+	50+	30	20	15
CM-40L/240	40	240	8 AWG	9600	0.75	50+	50+	34	23	17

Note 1: Maximum temperature rise may be governed by preset outlet temperature.

Note 2: Local plumbing and electrical codes must be followed for installation of water heater and the accessories.

Chronomite Laboratories assumes no responsibility for use of void or suspended data. © Copyright Chronomite Laboratories, Inc. Member of Morris Group International, City of Industry, CA Please visit www.chronomite.com for most current specifications.

SELECTION SUMMARY & APPROVAL FOR MANUFACTURING	Company _____	CHRONOMITE LABORATORIES, INC. PH. 800-447-4962 626-937-4270 FAX 626-937-4279 www.chronomite.com
	Model Number & Options _____ Quantity _____	
	Contact _____ Title _____	
	Signature (Approval for Manufacturing) _____	
	Date _____	

INSTANT-FLOW® C-MICRO - LOW ACTIVATION

TECHNICAL DIMENSIONS

INSTANT-FLOW® C-MICRO - LOW ACTIVATION

Dimensions:	159 (H) x 244 x 70mm
Weight:	2.27 Kg
Materials:	Rugged cast aluminum housing Celcon plastic element assembly with nichrome coils
Housing Color:	White
Minimum Operating Flow Rate:	0.75 LPM
Minimum Operating Pressure:	172 kPa
Maximum Operating Pressure:	552 kPa
Maximum Pressure:	1034 kPa
Maximum Water Temperature:	71°C
Maximum Ambient Operating Temperature:	60°C
Listing:	UL, IAPMO, UPC, ADA, ETL

GENERAL NOTES:

- The microprocessor adjusts the heater's power for variations in flow rates, inlet water temperature and pressure to assure the selected factory preset water temperature.
- 240V models when operated at 220V will have approximately a 15% wattage decrease.
- 120V models when operated 110V will have approximately a 15% wattage decrease.
- Instant-Flow C-Micro is ideal for sensor/hands-free faucets with the 104°F (40°C factory preset setting temperature ; no mixing valve needed
- Factory setting of 110°F or above require cold water mixing at the hand wash faucet.
- Microprocessor limits temperature increase according to the pre-selected temperature.

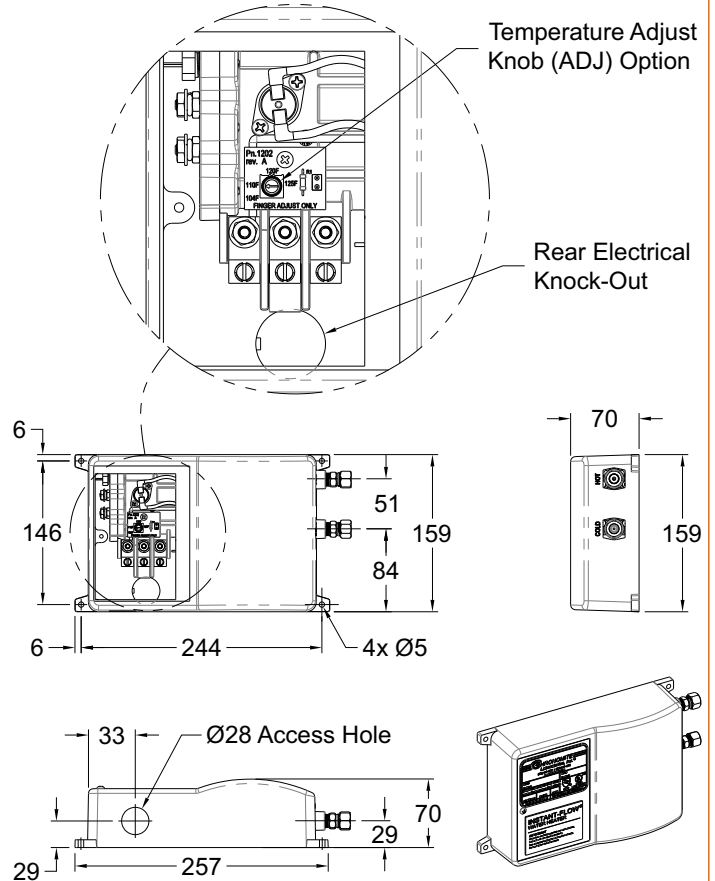

Chronomite Laboratories assumes no responsibility for use of void or suspended data. © Copyright Chronomite Laboratories, Inc. Member of Morris Group International, City of Industry, CA Please visit www.chronomite.com for most current specifications.

SELECTION SUMMARY & APPROVAL FOR MANUFACTURING	Company _____
	Model Number & Options _____ Quantity _____
	Contact _____ Title _____
	Signature (Approval for Manufacturing) _____ Date _____

CHRONOMITE
LABORATORIES, INC.
PH. 800-447-4962
626-937-4270
FAX 626-937-4279
www.chronomite.com

INSTANT-FLOW® C-MICRO - LOW ACTIVATION

TECHNICAL DIMENSIONS

INSTANT-FLOW® C-MICRO - LOW ACTIVATION

Dimensions:	6-1/4" (H) x 9-5/8" x 2-3/4"
Weight:	5 lbs.
Materials:	Rugged cast aluminum housing Celcon plastic element assembly with nichrome coils
Housing Color:	White
Minimum Operating Flow Rate:	0.2 GPM
Minimum Operating Pressure:	25 PSI
Maximum Operating Pressure:	80 PSI
Maximum Pressure:	150 PSI
Maximum Water Temperature:	160°F
Maximum Ambient Operating Temperature:	140°F
Listing:	UL, IAPMO, UPC, ADA, ETL

GENERAL NOTES:

- The microprocessor adjusts the heater's power for variations in flow rates, inlet water temperature and pressure to assure the selected factory preset water temperature.
- 240V models when operated at 220V will have approximately a 15% wattage decrease.
- 120V models when operated 110V will have approximately a 15% wattage decrease.
- Instant-Flow C-Micro is ideal for sensor/hands-free faucets with the 104°F (40°C) factory preset setting temperature ; no mixing valve needed
- Factory setting of 110°F or above require cold water mixing at the hand wash faucet.
- Microprocessor limits temperature increase according to the pre-selected temperature.

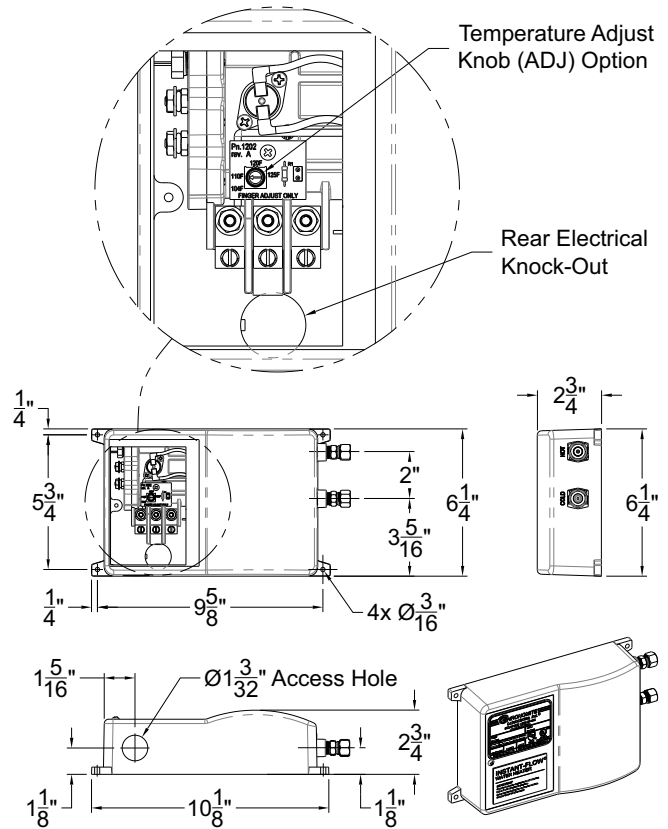

Notes:

- Heater to be installed below the level of all hot water outlets serviced by the Heater.
- Diagram shown with standard 3/8" Compression Fitting. Optional 1/2" NPT Male water connections available.

- ① Instant-Flow Micro Heater
- ② Electrical Junction Supply Box (Optional)
- ②A 2095-1 Disconnect Switch (Optional)
- ③ Electrical Supply Conduit
- ④ Electrical Supply Wire
- ⑤ Dual Outlet Stop, 3/8" Comp. Outlet Connections
- ⑥ 3/8" Comp. x 1/4" NPT Fittings (supplied)
- ⑦ 3/8" Hot Water Outlet
- ⑧ 3/8" Cold Water Inlet

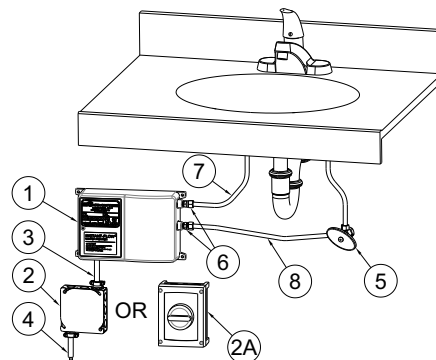

WIRING CONNECTION

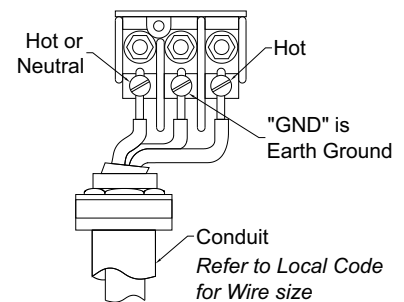

ATTENTION:

Unit must be hard wired.

NOTE: Heaters are single phase. All tests are measured at the output of the heater.

Chronomite Laboratories assumes no responsibility for use of void or suspended data. © Copyright Chronomite Laboratories, Inc. Member of Morris Group International, City of Industry, CA Please visit www.chronomite.com for most current specifications.

SELECTION SUMMARY & APPROVAL FOR MANUFACTURING

Company _____

Model Number & Options _____ Quantity _____

Contact _____ Title _____

Signature (Approval for Manufacturing) _____ Date _____

CHRONOMITE
LABORATORIES, INC.
PH. 800-447-4962
626-937-4270
FAX 626-937-4279
www.chronomite.com