

RHINO

greenhouses *direct*

Premium

10x10, 10x12, 10x14, 10x16, 10x18, 10x20
Assembly instructions



Greenhouses Direct Ltd
www.greenhousesdirect.co.uk
Service department open Monday to Friday 9am - 5.30pm
0344 493 1929
service@greenhousesdirect.co.uk

RHINO Premium greenhouses *direct*

Online video

Go to our YouTube channel: www.youtube.com/user/Rhinogreenhouses

Please start by watching the Greenhouse delivery and installation video, this will provide important background information.

QR codes



As you will be in your garden erecting the greenhouse it may well be that you will find it easier to watch the videos on a smartphone or tablet. To help with this, each video has been assigned a QR code.

QR code scanners can be downloaded for free online. Once installed, simply scan the code with your smartphone or tablet and it will take you directly to the correct video.



Digitally printed on 120gsm Recycled Evolution paper
Dynamic Print Norwich capture the CO2 emissions from their paper purchases by planting native woodland, right here in the UK, through the Woodland Trust and the Woodland Carbon scheme.

10x10

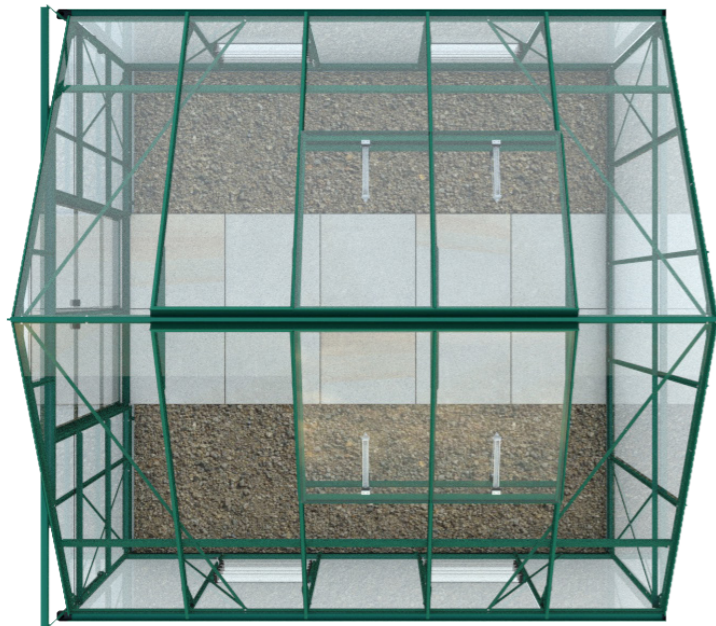
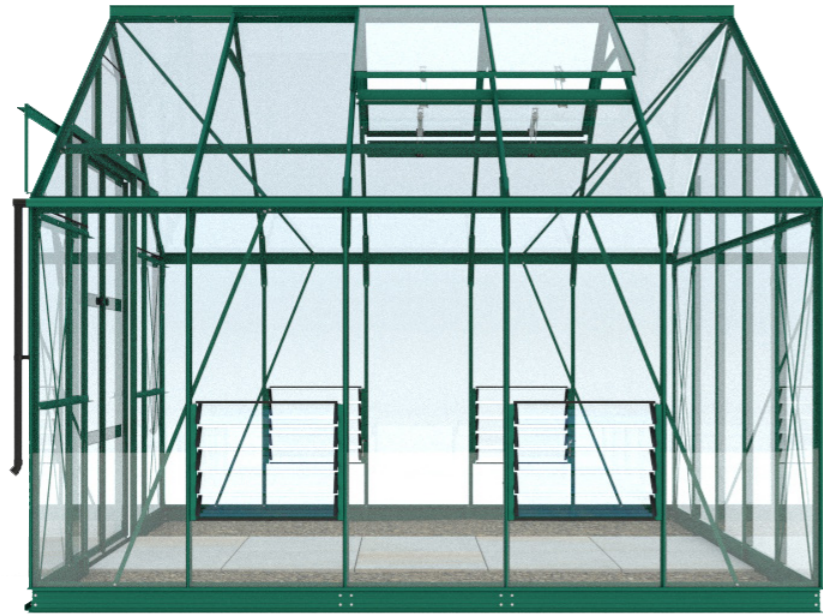

10x12



10x14

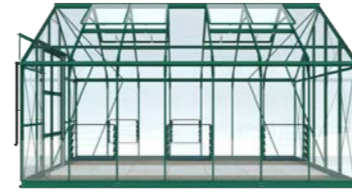

10x16



10x18

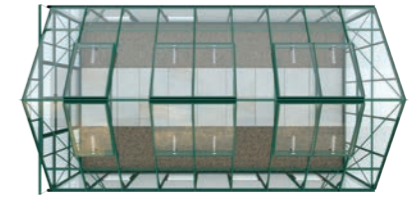

10x20



Part No	Description	10x10	10x12	10x14	10x16	10x18	10x20
R93/45	Bayliss XL Autovent Opener	4	6	8	8	10	12
End pack							
R05/1	Heavy glazing bar rear size 8 2351mm	2	2	2	2	2	2
R05/3	Heavy glazing bar rear size 6 1928mm	2	2	2	2	2	2
● R15/1	2ft Door x member top 614mm	2	2	2	2	2	2
● R16/1	2ft Door transom 575mm	4	4	4	4	4	4
R17/4	10' door track mount 1886mm	1	1	1	1	1	1
R18/3	10' door track 3088mm	1	1	1	1	1	1
● R31/4	Door track support 368mm	2	2	2	2	2	2
R32/41	10' top stay rear 3068mm	1	1	1	1	1	1
R32/43	10' top stay front 923mm	4	4	4	4	4	4
R33/2	end stay 1535mm	8	8	8	8	8	8
R33/4	10' stay roof 2215mm	4	4	4	4	4	4
R71/1	Door post 1993mm	2	2	2	2	2	2
R72/10	Base 10' end 3160mm	1	1	1	1	1	1
R72/23	Base Flush Door end LH 961mm	1	1	1	1	1	1
R72/24	Base Flush Door end RH 961mm	1	1	1	1	1	1
R74/5	Lower Door guide 10ft wide	1	1	1	1	1	1
R75/3	Ramp 4ft 1238mm	2	2	2	2	2	2
● R79/3	Glazing bar ctr front 440mm	2	2	2	2	2	2
R79/4	Glazing bar 1910mm	2	2	2	2	2	2
R83/1	Door stile 1913mm	3	3	3	3	3	3
R85/1	Meeting stile 1913mm	1	1	1	1	1	1
● R86/1	Door x member bottom 614mm	2	2	2	2	2	2
R92/9	Glazing Bead long 2347mm	18	18	18	18	18	18
R92/57	Door Wool Pile Classic/Premium Fitted	1	1	1	1	1	1
R92/58	Guide Rail woolpile Fitted	1	1	1	1	1	1
R92/21	Low modulus clear silicone	1	1	1	1	1	1
R93/55	Corner Base Anchor	4	4	4	4	4	4
R92/14	H Section (Above Door) 588mm	3	3	3	3	3	3
R92/64	Guide rail filler strip 926mm	2	2	2	2	2	2
Door fixings pack							
R90/10	M8 Hexagonal Lock Nuts Stainless Steel	8	8	8	8	8	8
R90/11	M8 nyloc Insert Nuts Stainless Steel	4	4	4	4	4	4
R90/9	M8x25 hex set stainless steel	4	4	4	4	4	4
R91/5	Glazing clips "W"	12	12	12	12	12	12
R92/1	Door wheels	4	4	4	4	4	4
R92/6	Door handle nylon male	2	2	2	2	2	2
R92/7	Door handle nylon female	2	2	2	2	2	2
R94/28	Door stop bracket	2	2	2	2	2	2
R90/46	M6 Flat nut stainless steel	4	4	4	4	4	4
R90/47	M6x8mm Socket button head stainless steel	4	4	4	4	4	4
R90/48	M4x8mm Pozi pan stainless steel	4	4	4	4	4	4
R90/49	Door stop buffer	4	4	4	4	4	4
Plate fixings pack							
R91/3	Eave plate	4	4	4	4	4	4
R91/4	Ridge plate	2	2	2	2	2	2
R93/56	Zed Bracket	2	2	2	2	2	2
R32/5	staging /hanging bskt cleat 16mm	4	4	4	4	4	4
R93/53	Guide Rail End Cap	2	2	2	2	2	2
R90/40	3.9x9.5mm Pan pozi self tapper stainless steel	4	4	4	4	4	4
Gutter fixings pack							
R92/25	LH outlet	1	1	1	1	1	1
R92/26	RH outlet	1	1	1	1	1	1
R92/27	LH stopend	1	1	1	1	1	1
R92/28	RH stop end	1	1	1	1	1	1
R92/29	LH downpipe clip	1	1	1	1	1	1
R92/30	RH downpipe clip	1	1	1	1	1	1
R92/31	32mm Bend-45 Degree Black	4	4	4	4	4	4
R90/23	M4 x 12mm hex set stainless steel	2	2	2	2	2	2
R90/24	3.5 x 12mm stainless self tapping screw	2	2	2	2	2	2
R90/3	M4 hex full nut stainless steel	2	2	2	2	2	2

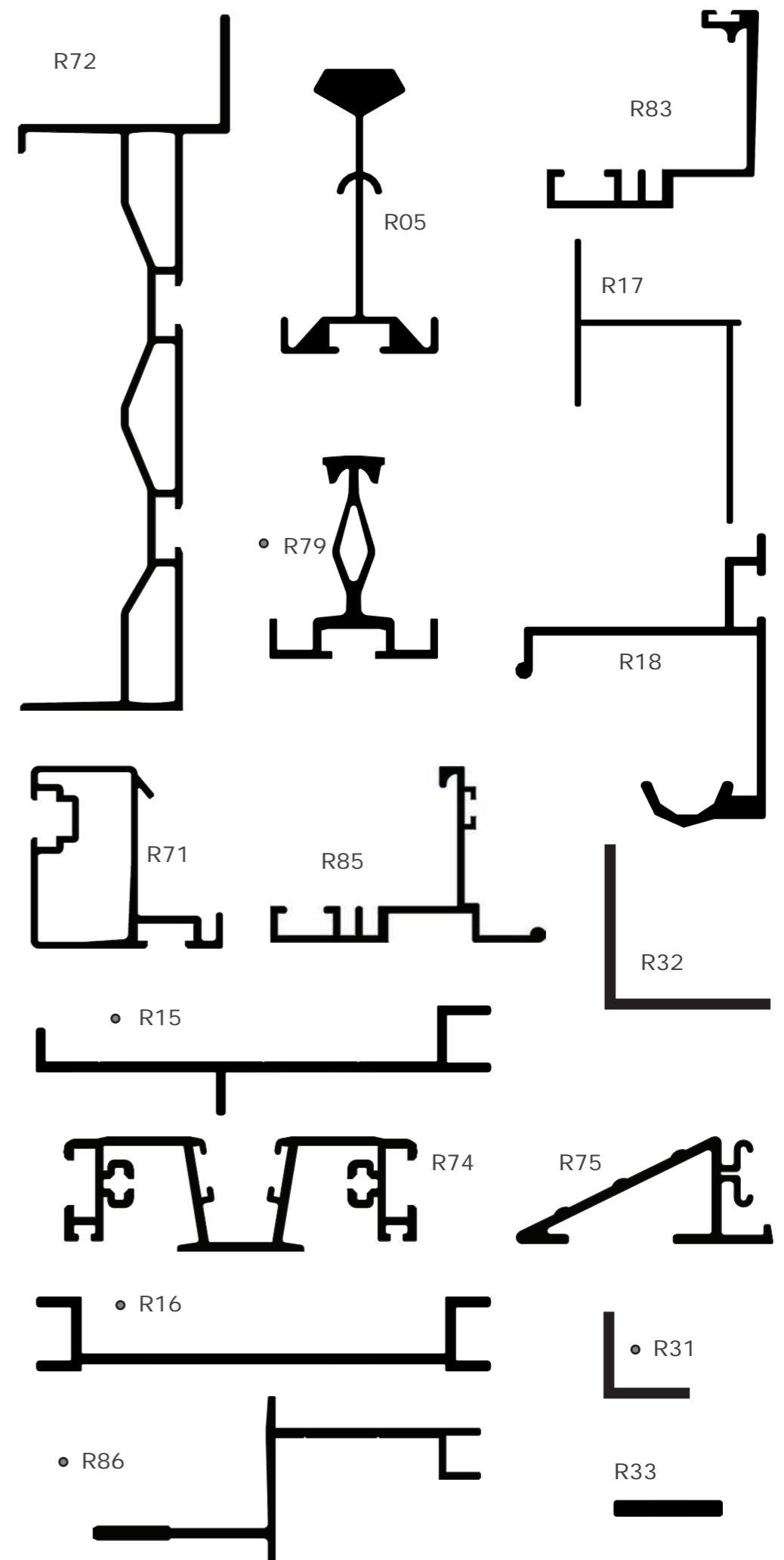

● Wrapped together

Part No	Description	10x10	10x12	10x14	10x16	10x18	10x20
LP1	Length pack 1						
R04/3	ridge 10' long 3113mm	1					
R04/4	ridge 12' long 3731mm		1				
R04/5	ridge 14' long 4349mm			1			
R04/6	ridge 16' long 4967mm				1		
R04/7	ridge 18' long 5585mm					1	
R04/8	ridge 20' long 6203mm						1
R08/11	hd eave 10' long 3113mm	2					
R08/12	hd eave 12' long 3731mm		2				
R08/13	hd eave 14' long 4349mm			2			
R08/14	hd eave 16' long 4967mm				2		
R08/15	hd eave 18' long 5585mm					2	
R08/16	hd eave 20' long 6203mm						2
R34/22	10' hanging basket rail 3050mm	2					
R34/23	12' hanging basket rail 3668mm		2				
R34/24	14' hanging basket rail 4286mm			2			
R34/25	16' hanging basket rail 4904mm				2		
R34/26	18' hanging basket rail 5522mm					2	
R34/27	20' hanging basket rail 6140mm						2
R72/3	Base 10' side 3121mm	2					
R72/4	Base 12' side 3739mm		2				
R72/5	Base 14' side 4357mm			2			
R72/6	Base 16' side 4975mm				2		
R72/7	Base 18' side 5593mm					2	
R72/8	Base 20' side 6211mm						2
LP2	Length pack 2						
R21/1	vent cill 1 bay 597mm		2			2	
R21/4	vent cill large cut out 2 bay 1215mm	2	2	4	4	4	6
R23/2	large vent side 960mm	4	8	8	8	12	12
R24/1	Large vent hinge 1bay 630mm		2			2	
R24/2	Large vent hinge 2 bay 1248mm	2	2	4	4	4	6
R32/7	vent crossbar 1 bay LARGE (87 degree) 634mm	4	6	8	8	10	12
R33/1	side/roof stay 1606mm	4	4	4	4	4	4
R79/7	Large vent glazing bar 960mm	2	2	4	4	4	6
R91/1	M8 'J' Bolt	9	9	11	11	11	13
R91/6	Tie rod Brackets	2	2	4	4	4	6
R92/12	glazing rubber	124	136	148	160	172	184
R92/16	H section glass joint	13	13	13	13	13	13
R92/17	H section glass joint 10/12ft roof	6	6	6	8	8	8
R92/35	32mm outlet pipe 1 metre Black	2	2	2	2	2	2
R92/46	Louvre Glass Seal Strip 558mm	8	8	10	10	12	12
R93/2	Louvre 5 blade frame 460mm	4	4	5	5	6	6
	Anchor fixings pack						
R90/15	M8 Full Nut Stainless Steel	22	22	30	30	30	38
R90/16	M8 flat washer stainless steel	22	22	30	30	30	38
R91/20	6 x 75 HEX FLANGE ANKERBOLT ZINC	9	9	11	11	11	13
R93/54	Base Anchor	5	5	7	7	7	9
	Nut and bolt fixings pack						
R90/19	M6 x 11 bolt High Tensile	430	450	470	490	500	520
R90/2	M6x22 Cruciform Head Aluminium Screws	2	2	2	2	10	2
R90/20	M6 Nut High Tensile	436	456	476	496	506	526
R90/22	M3 x 8mm bolt Stainless st	8	8	16	16	16	24
R90/38	M3 nyloc inserts stainless steel	8	8	16	16	16	24
	Vent and louvre fixings pack						
R90/5	M6x11 cropped head aluminium	2	4	4	4	6	6
R91/17	Large window lock L/H	2	3	4	4	6	6
R91/22	Large window lock R/H		1				
R92/49	Louvre End Cap	16	16	20	20	24	24
R92/55	Roof Vent Stops	4	8	8	8	12	12
R92/7	Door handle nylon female	2	4	4	4	6	6

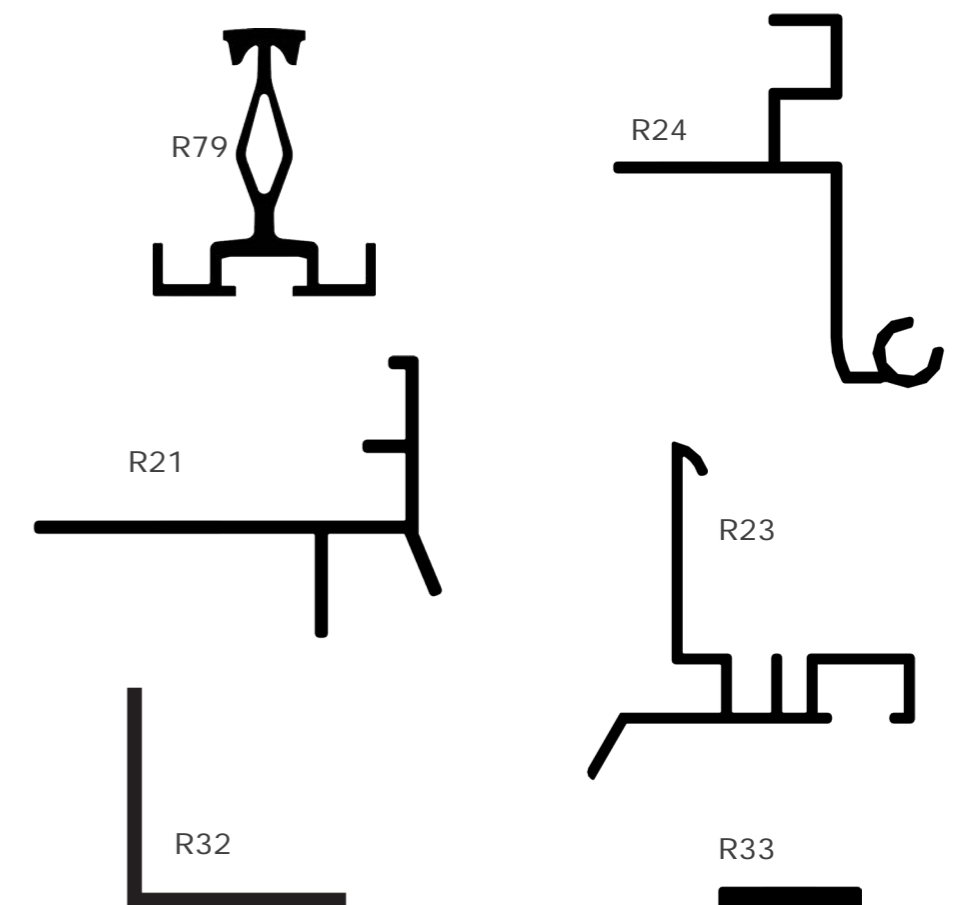
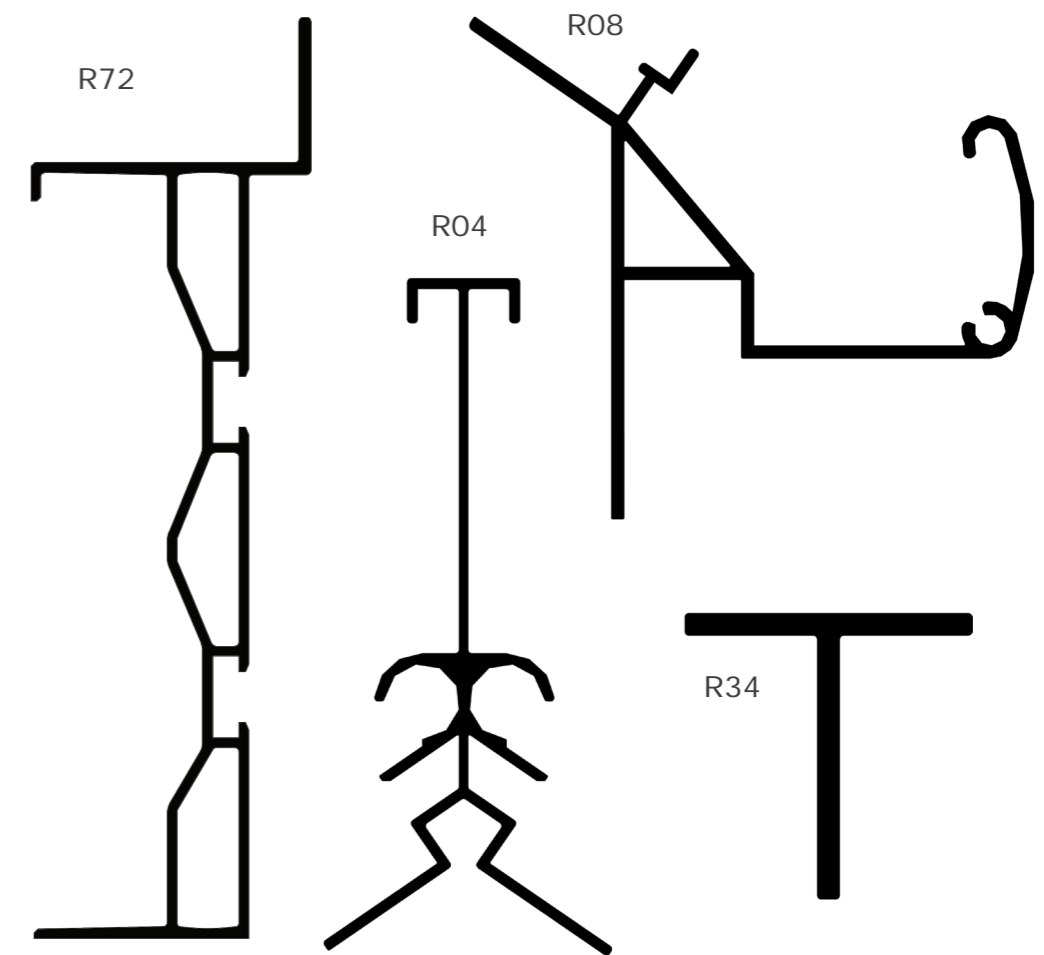

Part No	Description	10x10	10x12	10x14	10x16	10x18	10x20
RP Roof pack							
R05/10	Heavy glazing bar, 10' roof 1866mm	8	10	12	14	16	18
R07/13	10' corner roof LH 1866mm	2	2	2	2	2	2
R07/14	10' corner roof RH 1866mm	2	2	2	2	2	2
R91/7	Tie rod 1800mm	1	1	2	2	2	3
R92/45	glazing bead 10ft roof 1924mm	25	29	33	37	41	45
SP Side pack							
R05/2	Heavy glazing bar size 1 1492mm	8	10	12	14	16	18
R07/1	corner side LH 1492mm	2	2	2	2	2	2
R07/2	corner side RH 1492mm	2	2	2	2	2	2
R34/20	Eave brace 360mm	8	10	12	14	16	18
R34/21	Ridge brace 680mm	4	5	6	7	8	9
R92/8	Glazing beads medium 1489mm	25	29	33	37	41	45
Glass							
RG/A 295x405	Glass A 295x405	2	2	2	2	2	2
RG/B 605x972	Glass B 605x972	10	12	14	16	18	20
RG/C 605x1502	Glass C 605x1502	13	15	16	18	19	21
RG/E 605x610	Glass E 605x610	4	4	4	4	4	4
RG/F 605x421	Glass F 605x421	3	3	3	3	3	3
RG/G 605x903	Glass G 605x903	14	12	14	16	18	20
RG/K 605x512	Glass K 605x512	2	2	2	2	2	2
RG/L 542x100	Glass L 542x100	20	20	25	25	30	30
RG/N Apex	Glass N Apex	2	2	2	2	2	2
RG/R 605x848	Glass R 605x848	4	4	5	5	6	6
RG/S Triangle Shape	Glass S Triangle Shape	8	8	8	8	8	8
RG/T 605x192	Glass T 605x192	4	4	5	5	6	6
RG/V 605x410	Glass V 605x410	2	2	2	2	2	2
RG/Z 295x1502	Glass Z 295x1502	2	2	2	2	2	2

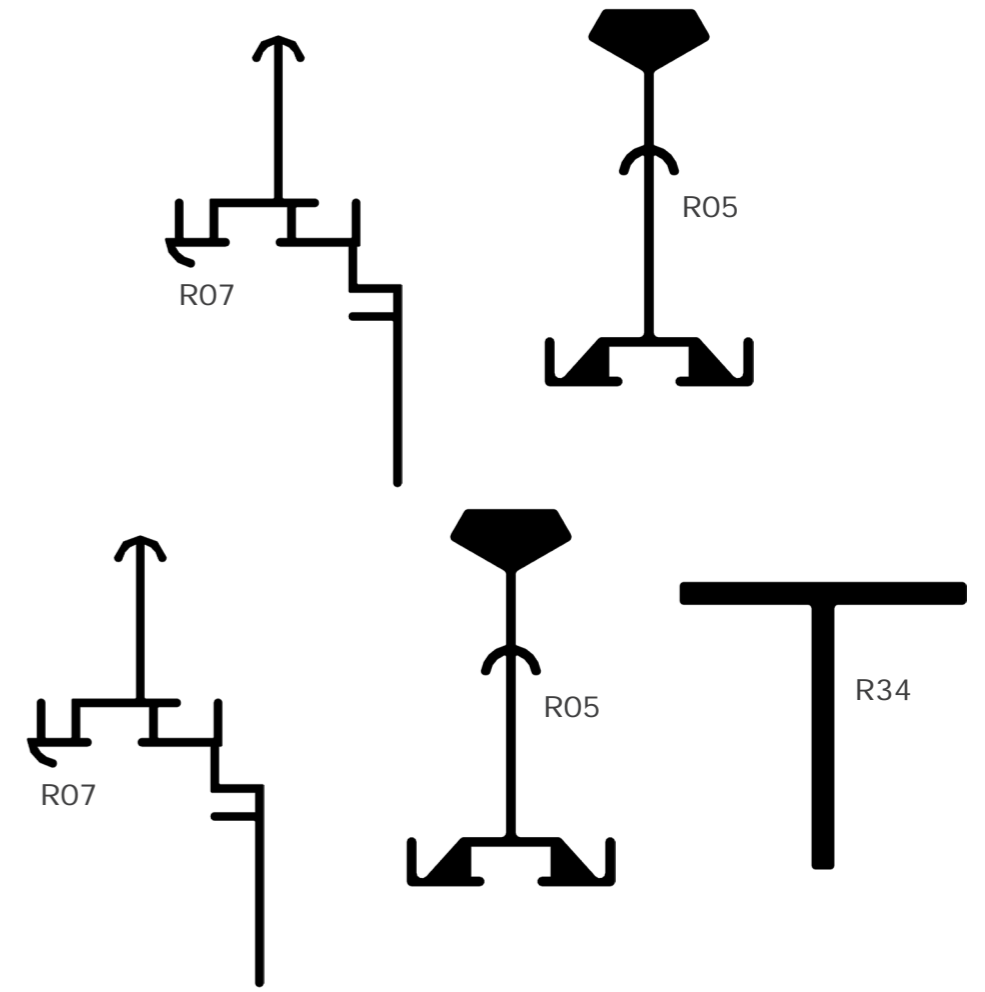

General Points before you start

1st of 6 pages



Introduction

You will need the following:

Someone to assist you
Sturdy stepladder
10mm spanner
10mm nut driver
13mm spanner
Hacksaw-preferably small
Tape measure
Skeleton gun for silicone
Spirit level
Drill (drill bits HSS 4.5 & 7mm. Masonry 6mm)
plus a few common tools
Bags of readymix for the anchors if erecting
on a soil site

In addition there are a few tools which are useful but not essential:

Glass sucker (for handling and adjusting the
large panes of glass) a rubber mallet and a
glazing paddle

These, more specialist tools, are available from
Greenhouses Direct if you wish to buy them.

Thoughts & considerations

Where you choose to site your greenhouse will
usually be dictated by the design of your garden
and personal choice so we will confine ourselves
to considering the different types of ground that
it is built on. Rhinos can be sited on either soil or a
hardstanding. Either way the main requirements
are that the greenhouse is erected both **square
& level**.

Soil bases are perfect provided that the soil is
compacted so that it doesn't subside or get washed
away, avoid freshly dug soil for this reason. If
siting on a lawn we would recommend that the
turf is cleared from an area at least 300mm (1ft)
greater than the size of the greenhouse - you
won't want grass inside and this will allow an
edge to mow over rather than cut right up to the
greenhouse base.

Rhinos all include integral aluminium bases
which sit directly onto the soil and have sturdy
ground anchors which can be concreted in to
the ground at strategic points. The concreting is
done last of all once the greenhouse is glazed.

Hardstanding bases are no problem for the
Rhino as the integral base has a wide lip.

Brick plinth bases are perfect for the Rhino,
but please make sure you study the specific
base plan on page 4.

Please also consider the following points:

Is the site level?

If not find some means of packing underneath
the aluminium base **it must be level**.

Is the area likely to flood?

Water on the outside of an oversize concrete pad
is likely to make its way under the aluminium
base and settle inside the greenhouse unless
steps are taken to seal the base or drain the
water away.

How will you fix it down?

Please see the next page

Proximity to fences, buildings etc

If at all possible leave adequate room all round
the Rhino to ease initial construction and any
subsequent maintenance for the greenhouse
and adjacent walls or fences.

Construction order

It is important to construct the Rhino in the
correct order. You may expect to have to position
the integral base as the first job but this would
in fact greatly complicate matters later on.
Once again it will help to have read the plans in
advance.

Open & identify the parts

We suggest that you are careful to lay out parts
in an orderly fashion - grouping sections that
are made of the same profile together but in
their different lengths.
Most sections either have a sticker containing
the part number on them or are grouped with
identical sections which include a sticker. This
will help you greatly in identifying the various
parts.

Consider the weather

Erecting a large greenhouse will take more than
a day. Before you start please consider what
steps you will take to protect the greenhouse
if you are leaving it overnight or for a few
days without the frame being fully glazed and
anchored. Even a completely unglazed frame
will need to be anchored down in some way if
there is a possibility of strong winds.

Colour powdercoat finish

The optional powdercoated finish is strong and
durable. Unlike traditional paint finishes it will
not flake and is very resistant to fade. Don't be
concerned if you notice some areas on a few
profiles where the paint is less dense. This is
due to some of the profiles being very intricate
with channels & cavities on both sides. The
decision of where the primary and secondary
painting surfaces and jig points are situated is
deliberate. This takes into account how visible
the profile will be on the finished greenhouse.

Caution

The edges of the extrusion can be extremely
sharp. You may wish to consider wearing thin
gloves at certain stages.
During glazing and handling glass we advise
you to wear protective eye goggles.

Handling glass

While you are moving & handling the glass be
aware that the toughening process makes it
vulnerable to knocks on its edges. Catching an
edge on concrete or brickwork whilst carrying it
can easily cause it to break. Of course, when it
is installed in the greenhouse the edges are all
well protected.

Step ladders

Take care when working on your stepladder,
especially when the ground is soft.

Is your level, level?

This may sound a daft question but it is surprising
how often it crops up. You will have real difficulty
erecting your greenhouse if your level is giving
the wrong readings.

Check it before you start:

Try it on a surface you believe to be level, note
the position of the bubble, turn it round (180
degrees) and check that the bubble gives the
same reading. If it doesn't buy a new one quickly
-you've just saved yourself a lot of work!

Plan ahead

See page 24 point 12. The roof vents are slid into
the end of the ridge section so enough clearance
must be allowed when siting the greenhouse.

Construction method

The greenhouse is assembled using aluminium
bolts & nuts because they will not rust. These
can be tightened reasonably tight but be careful
not to over-tighten, as being much softer than
steel they will eventually shear.

**PLEASE NOTE! BEFORE USING THESE
FIXINGS IT IS ESSENTIAL THEY ARE
LUBRICATED WITH WD40 OR EQUIVALENT.**

The method used mostly in the construction of
your greenhouse is shown below. The head of a
bolt is slid in to the channel in the glazing bar
where it is held captive and cannot turn.

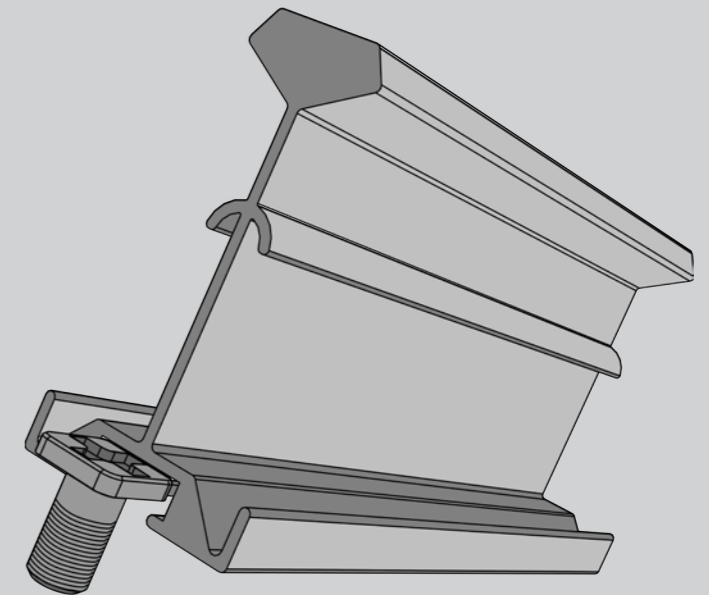

Generally it is best to leave nuts reasonably loose
in the early stages of assembling the frame as it
is possible to tighten them in slightly the wrong
position and then find that the various parts will
not fit together correctly. Certainly where the
bolt is passing through two holes such as at the
eave and ridge plates it is best to leave them
loose. Where the bolt slides in a captive nut
channel such as when fitting the glazing bars
you will have to partly tighten the nut so that
the bolt doesn't slide out.

The instructions will tell you when to go round
and tighten the bolts.

**General Points
before you start**
2nd of 6 pages



Ground anchors on a soil site

This section describes the anchor system and will be referred to later in the instructions.

The Rhino is very strong but to resist being blown over in high winds it must be anchored firmly to the ground. The **ground anchors** are made from stainless steel. They not only provide a secure anchor point but also add rigidity to the base. There are two types of anchors.

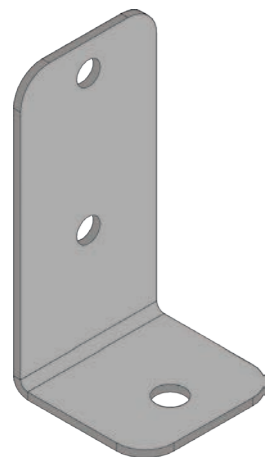

Base anchor

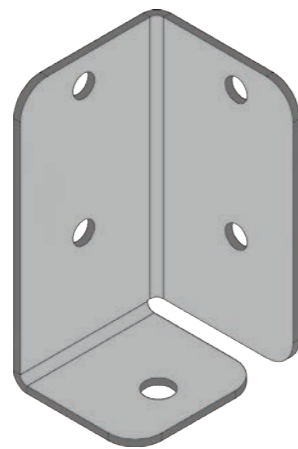

Base corner anchor

The number and location of the ground anchors will depend upon the size of Rhino you have ordered. Please refer to the plans on page 6 for more details.

Method

The ground anchors fix to the frame as shown here. Note that you will need to slide bolts along the nut channels in the base to the correct position.

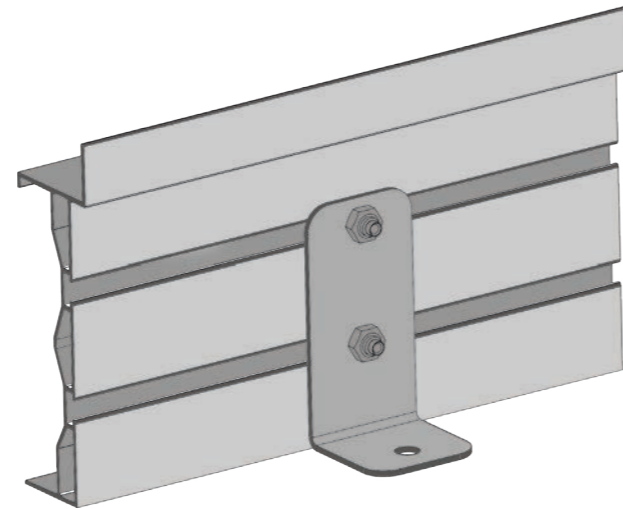

Fitting onto soil

Dig a good hole under each ground anchor. The exact dimensions of the hole will depend on ground conditions but approx 6" x 6" wide x 10" deep (150mm x 150 x 250 deep) will usually suffice.

Fit one of the "J" bolts to the anchor (with 2xM8 washers & 2xM8 nuts) and leave it hanging in the hole until the instructions indicate you should concrete it into position. Note that this will be after glazing has been completed, thereby allowing any adjustments to be made to the frame.

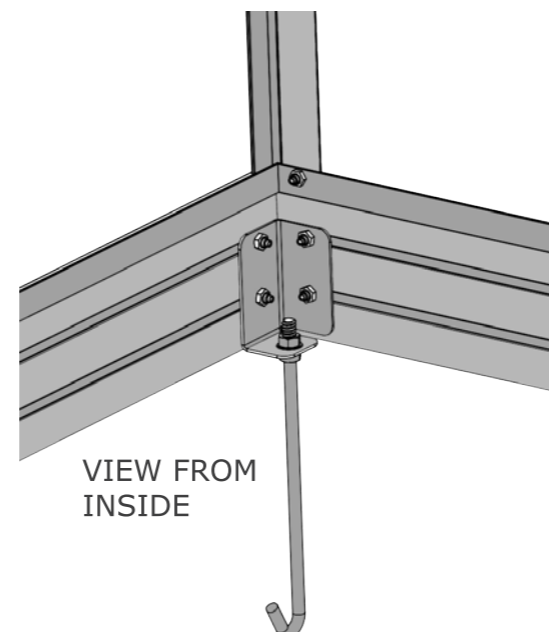

VIEW FROM INSIDE

Fitting onto concrete

The base on a Rhino is ideally suited to fixing onto a hardstanding because it is well balanced with the wide flat bottom section. Concrete pads are not always dead level and it may be that the base will need packing to even out any undulations. The base of the greenhouse must be fitted level.

The Ground Anchors are fitted in the same way as described in the previous section but note that the "J" bolts are not used in this instance.

Drill into the concrete through the hole in the ground anchor using a 6mm masonry drill bit. Fix down using the special concrete screws as provided. These screws are tightened directly in to the hole, no rawl plugs are required. Again, be sure not to fix the base down until indicated in the instructions.

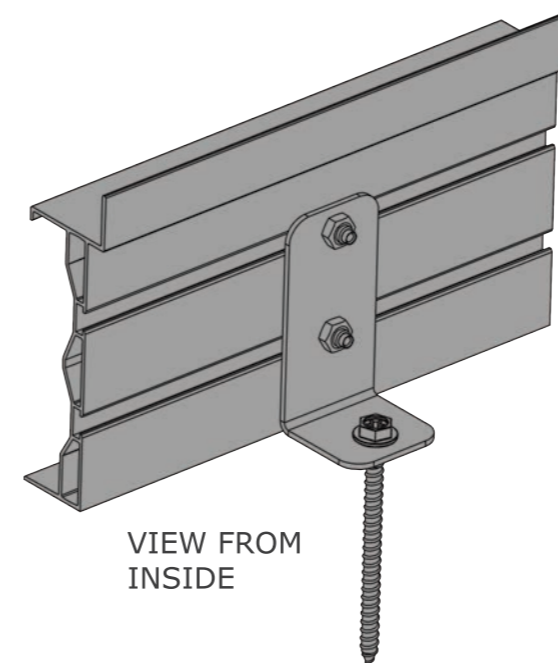

VIEW FROM INSIDE

Fitting onto paving slabs

Whilst a well laid paving slabbed area is ideal as a location for a Rhino, please be aware of the following.

Let us assume that your size of Rhino has 9 Ground Anchors supplied and that you screw all of these down to the slabs. All that has been achieved is that the Rhino has 9 slabs added to the weight of it, not the whole concrete slabbed area. In sheltered situations this may be adequate as it is likely to be sufficient to prevent the greenhouse being blown sideways.

In a windy location we would recommend lifting the slabs where the anchors are positioned and fixing it as described in the section "Fitting onto soil." You could make good with the concrete or by cutting and refitting the slabs around the anchors. This will ensure that the greenhouse is adequately anchored, bear in mind too, that we can supply further anchors if needed.

One final consideration. If you plan to lay slabs but have not already done so, you could fit the greenhouse onto soil and fix it down with concrete as previously described. You could then slab all or part of the inside of the greenhouse once it is installed.

Fitting to brickwork (as in a brick perimeter wall). Much of what we have written in the previous section "Fitting onto paving slabs" applies here.

Note that you are only really fixing the greenhouse to one brick with each ground anchor. You may wish to order additional anchors for this arrangement.

Fitting onto brickweave paving

Please see the earlier section "Fitting onto paving slabs."

We supply sufficient anchors to suit the vast majority of locations. If, however you feel that your particular site warrants extra fixings then please contact our sales department who will be pleased to assist (Telephone 0344 493 1929 service@greenhousesdirect.co.uk)

Check & tick before moving on...

- Do not fix the anchors down until told to do so, later in the instructions!!!

**General Points
before you start**
3rd of 6 pages

Base Footprint

The footprint shown here is the point of contact between the base section and the ground. The most common installation method is for the greenhouse to be sited on firm soil and for the ground Anchors (supplied) to be concreted into the soil after the greenhouse has been glazed. The location of the anchors varies according to the model.

Please ensure that 32.00mm is added to the overall base length to accommodate the door ramp.

Soil bases

Please note that on completion of your Rhino, the internal and external ramps must be supported. The best way to achieve this is to excavate the soil and lay a path as shown.

Hardstand

The most common hardstand bases are either a full slab base, or full concrete base.

However if for example you decide on installing a concrete strip foundation, you must be sure to make allowances for fixing down through each anchor as shown below. Failing to make the concrete strip wide enough could result in the foundation cracking as you drill the anchors points.

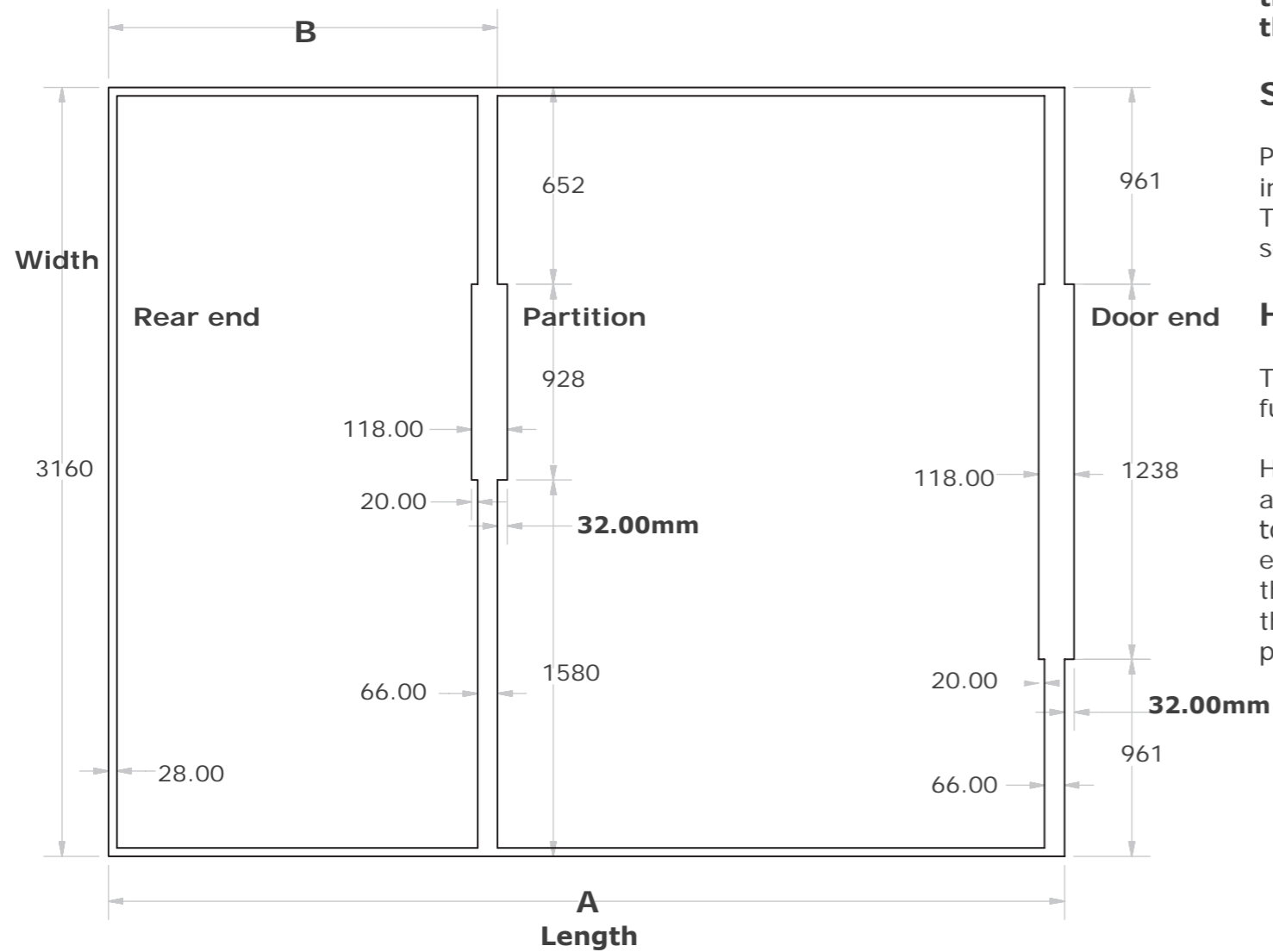
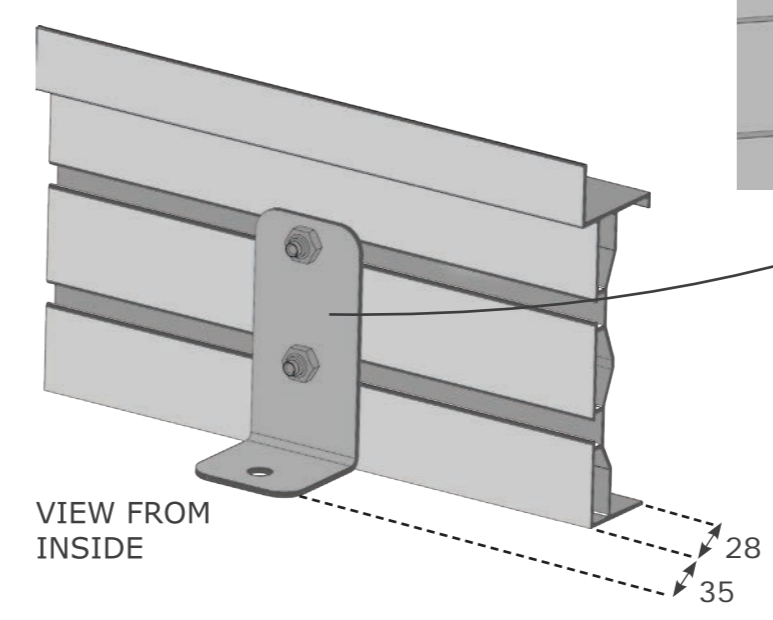
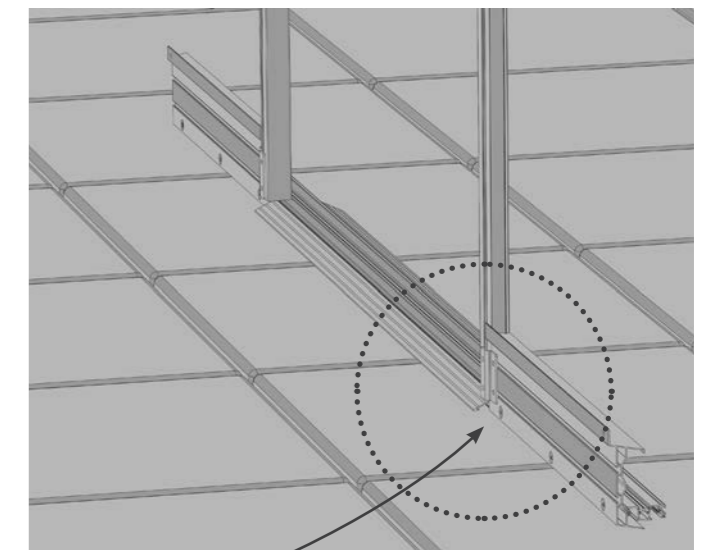
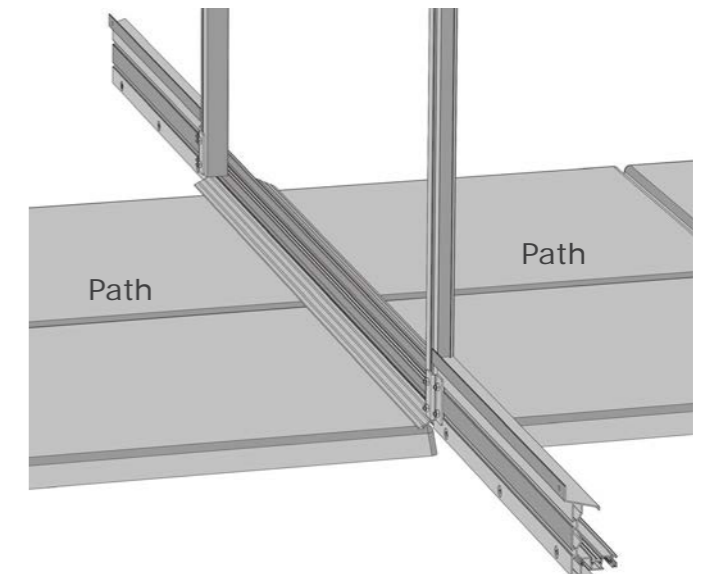

		12'	14'	16'	18'	20'
Length mm	A	3777	4395	5013	5631	6249

Please note, the dimensions below are only required if you have ordered a partition with your greenhouse.

		6'	8'	10'
Partition mm	B	1897	2515	3133

Greenhouses Direct DO NOT RECOMMEND the use of hardcore or hogging as suitable base materials due to issues surrounding levelling and securing of greenhouse.

**General Points
before you start**
4th of 6 pages

Brick Plinth Base plan

This Base plan must be adhered to allow the correct installation and subsequently allow for correct anchoring.

Once the base is built, position the greenhouse so that the Inside of the front door base is aligned

flush with the inside row of bricks. The sides and rear base will finish flush with the outside edge of the bricks. This will ensure that the Anchors can be fitted correctly. See below for full details.

Please note that on completion of your Rhino the internal ramp must be supported. The best way to achieve this is to install a path as shown.

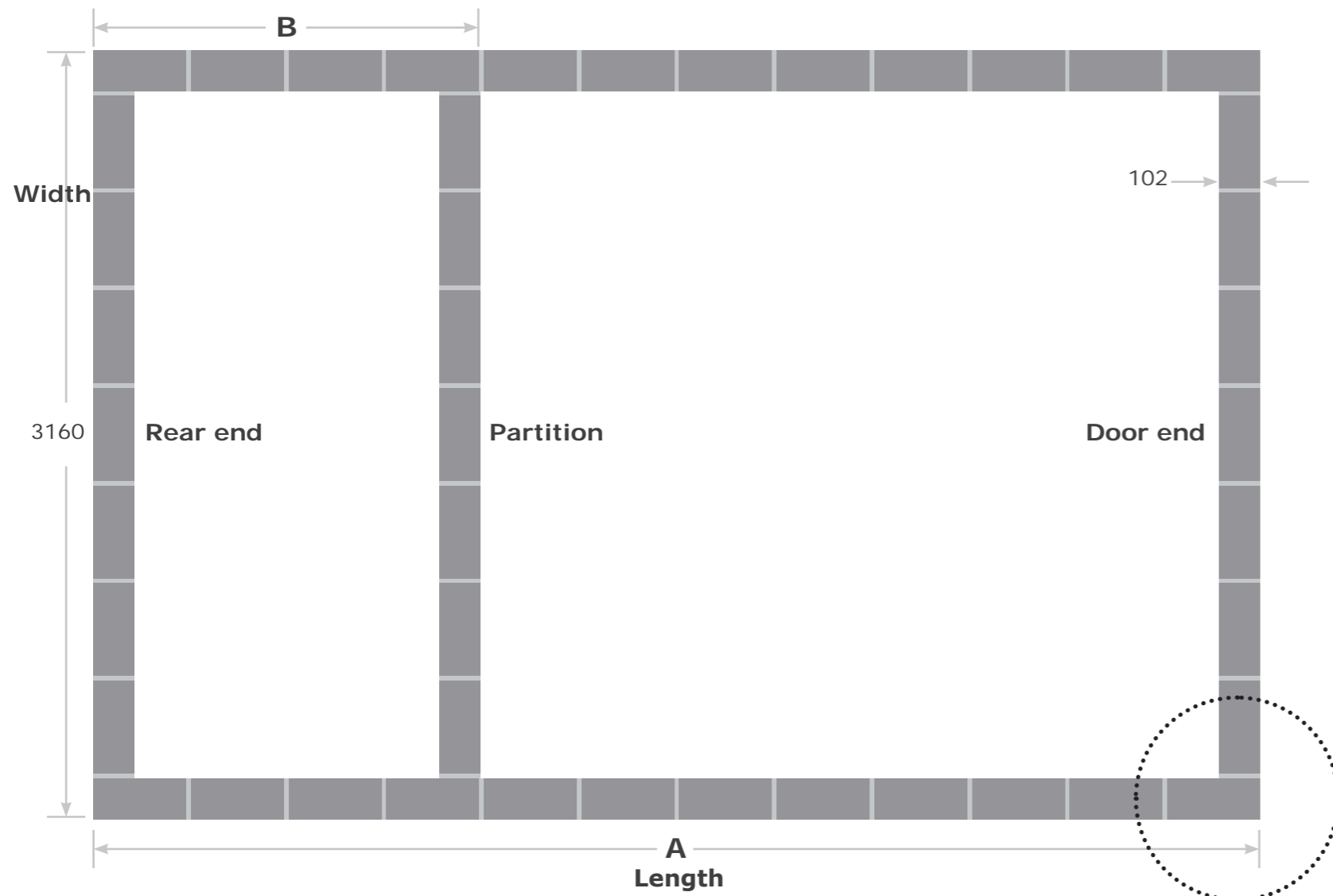

		10'	12'	14'	16'	18'	20'
Length mm	A	3195	3813	4431	5049	5667	6285

		6'	8'	10'
Partition mm	B	1929	2547	3165

Greenhouses Direct do not recommend the use of hardcore or hogging as suitable base materials due to issues surrounding levelling and securing of greenhouse.

If opting for this type of installation, please contact the service desk on 0344 493 1929 to request 2x modified ground anchors.

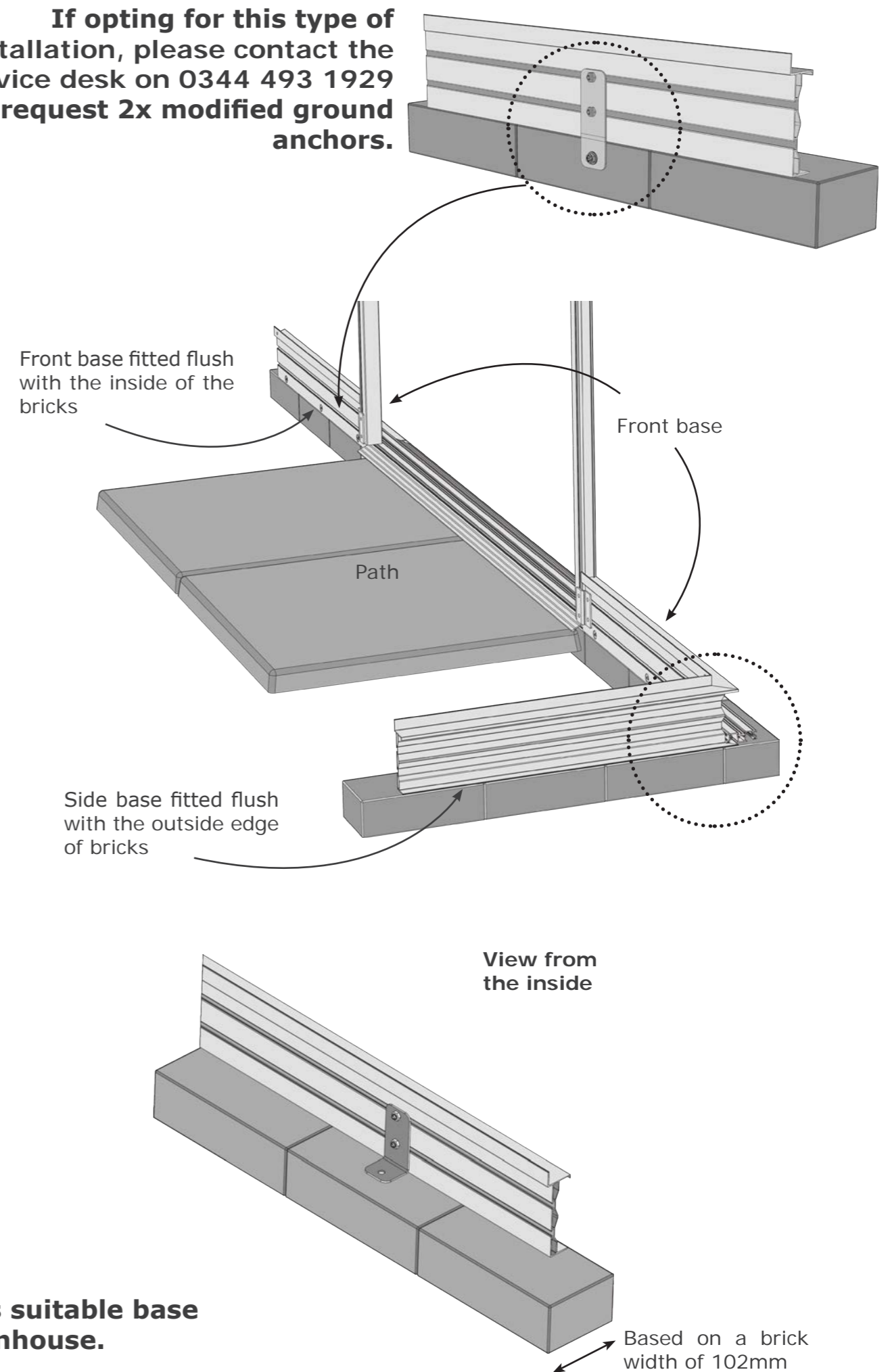

**General Points
before you start**
5th of 6 pages

The next 2 pages describes the layout of your Rhino and will be referred to later in the instructions.

Familiarise yourself with the layout of your Rhino by checking your order/invoice. Your frame and glass will be packed according to the specification noted on that document.

Roof vents

Unless specified differently on your order, your Rhino will have the roof vent configuration as shown here. There are a few models where some variation to the plans is possible, but note that roof vents will not fit in adjacent bays – there must be at least one bay between vents:

Partition

If you have ordered a partition, draw its position on the plan to act as a reminder and so that you can refer back to it during construction.

When you are building the sides, as early as page 7 you will need to refer to these plans for the position of the partition.

Louvre vents

Your Rhino will include 5 blade louvres as standard. The quantity does vary between sizes. Please check the parts list to determine the quantity for your model. Decide where you want to fit them and draw them on the plan for later reference.

Note: The louvres can not be fitted in the bays shown shaded on the plans on page 6.

Louvres can fit singly in bays like this:

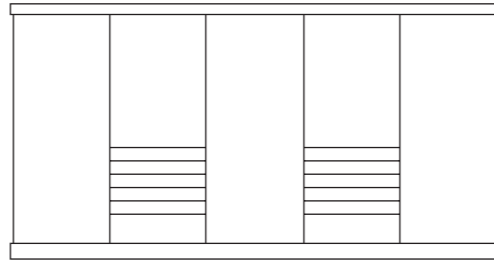

Or side by side like this:

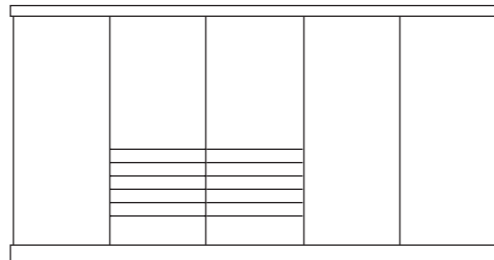

Fitting of Louvres in the rear:

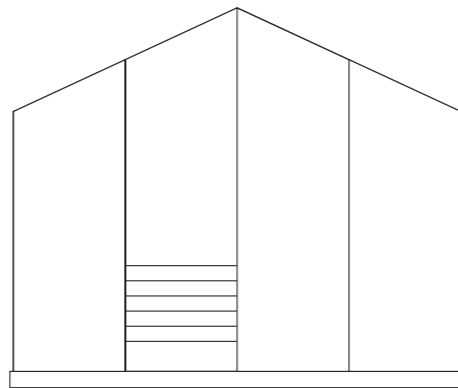

Singly

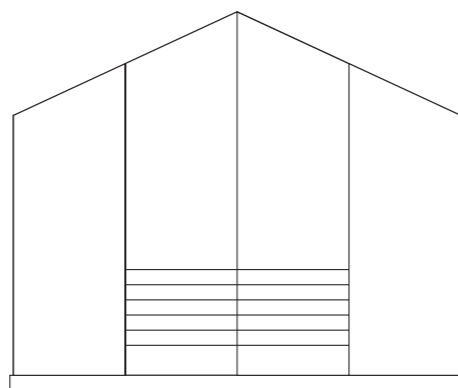

Side by side

Glazing plans

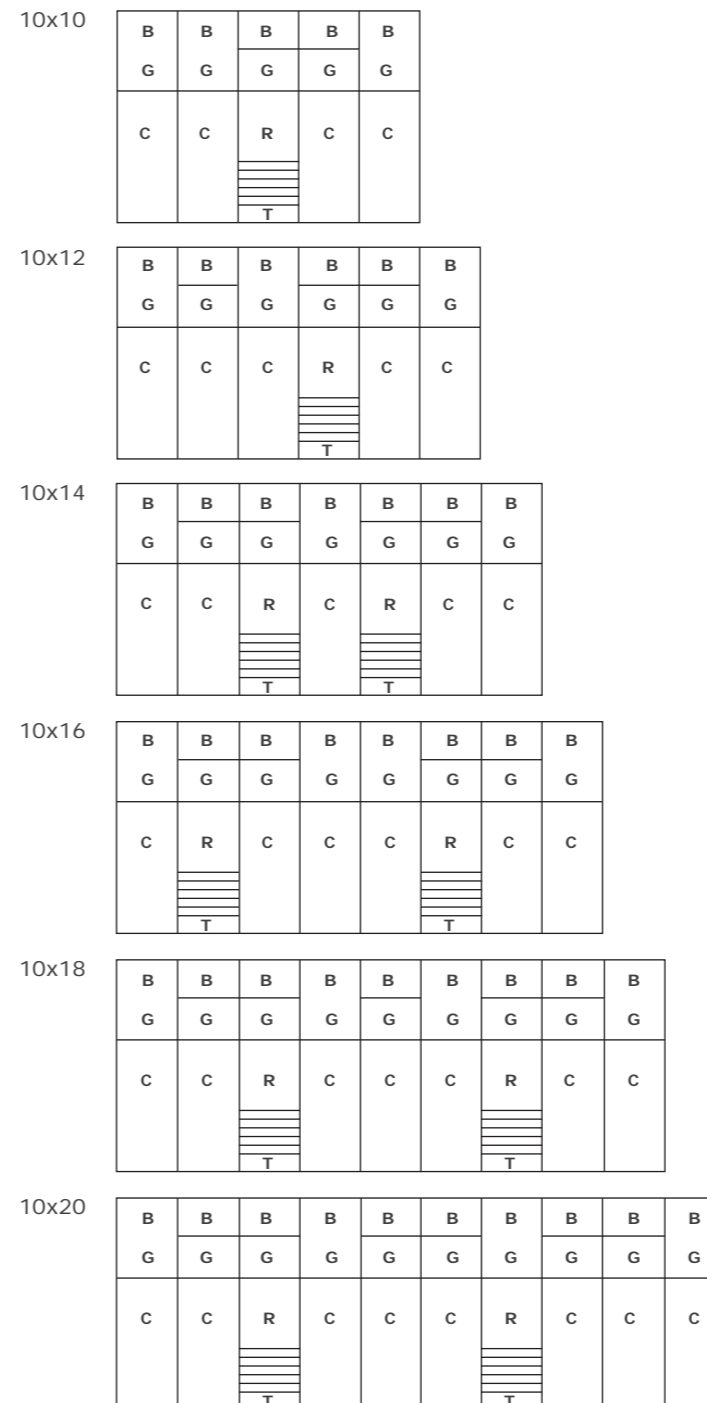
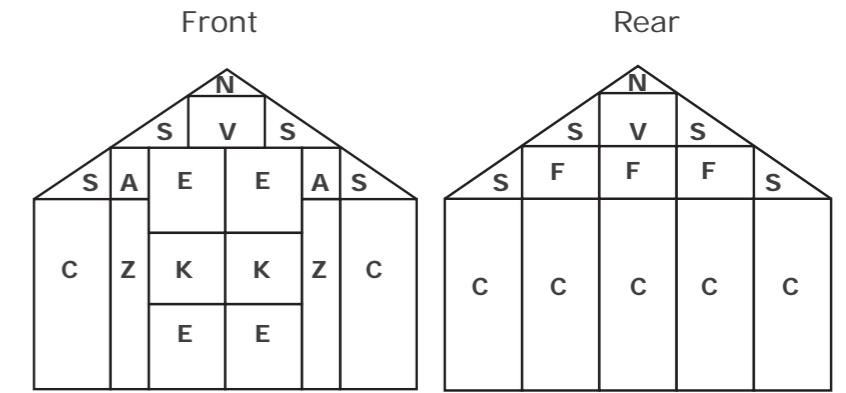

**General Points
before you start**
4th of 4 pages

**Plans showing details of roof
vents, louvre vents & ground
anchors**

If you have ordered extra anchors, draw them in now on the plans so that you can turn back and refer to this during construction.

Flush Door front view

10x10

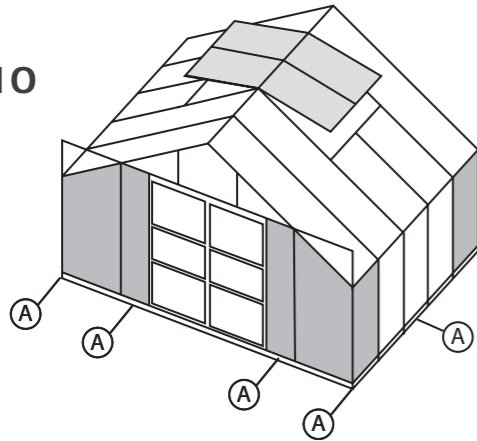

10x12

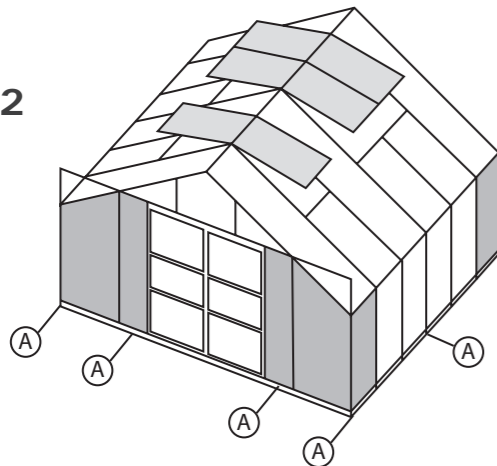

10x14

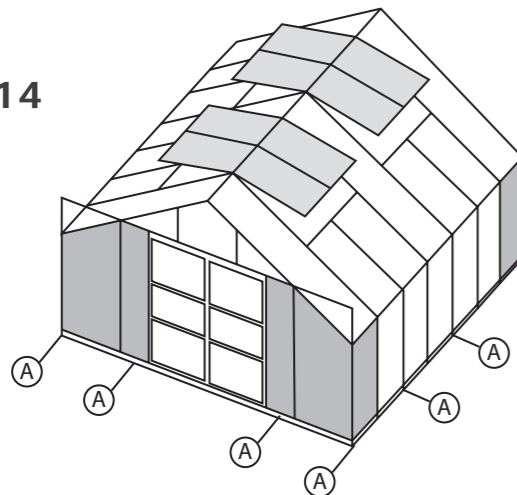

All Models rear view

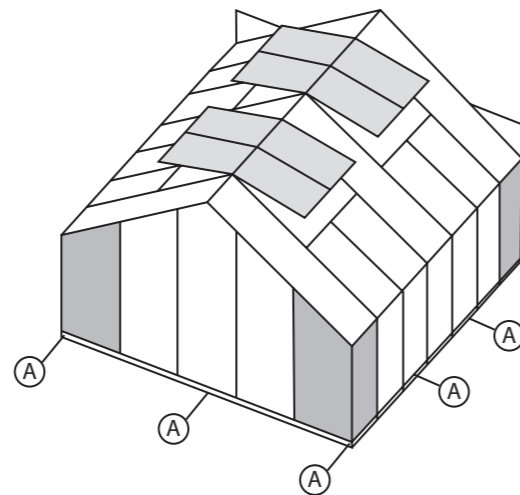
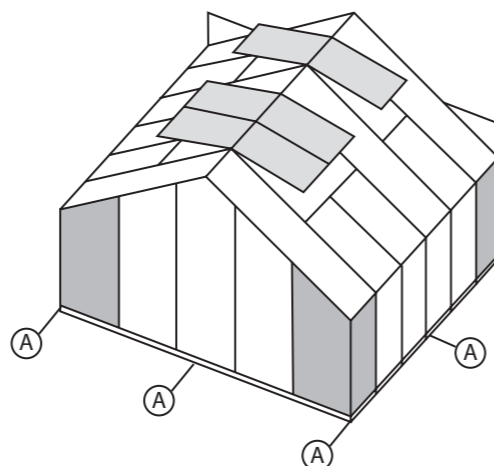
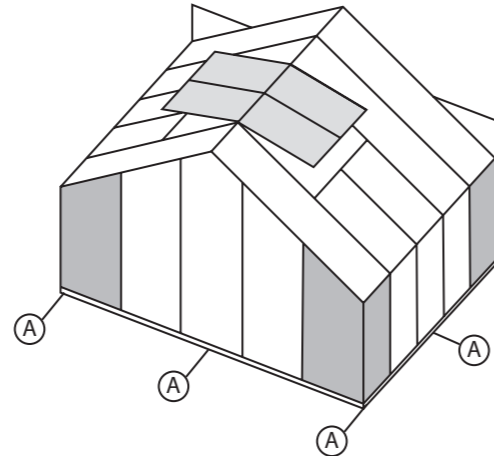

Flush Door front view

10x16

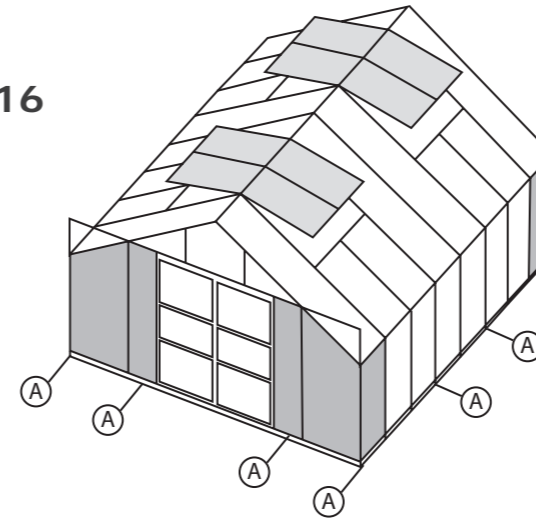

10x18

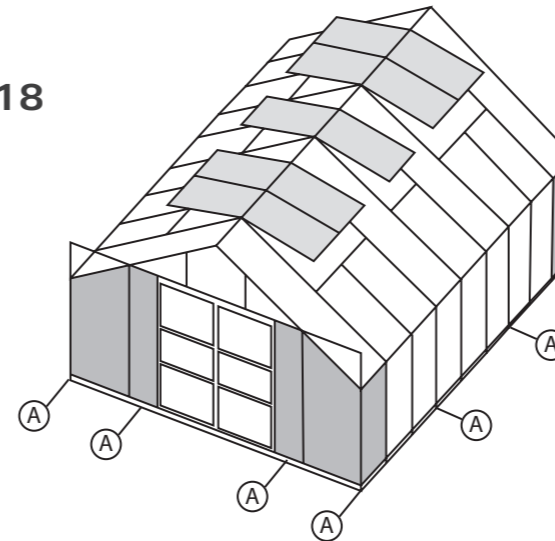

10x20

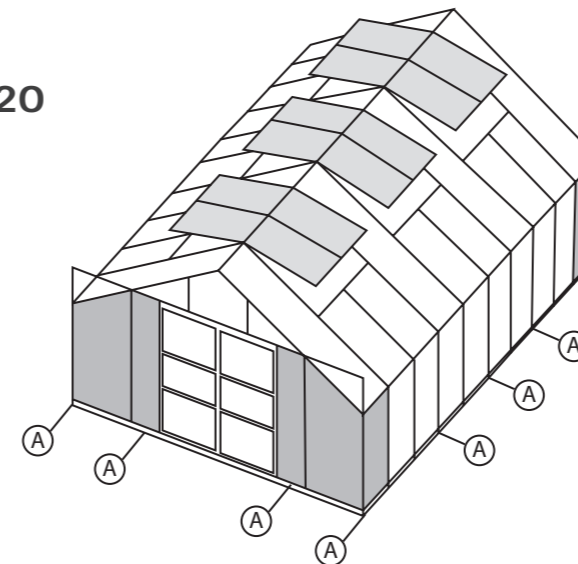

All Models rear view

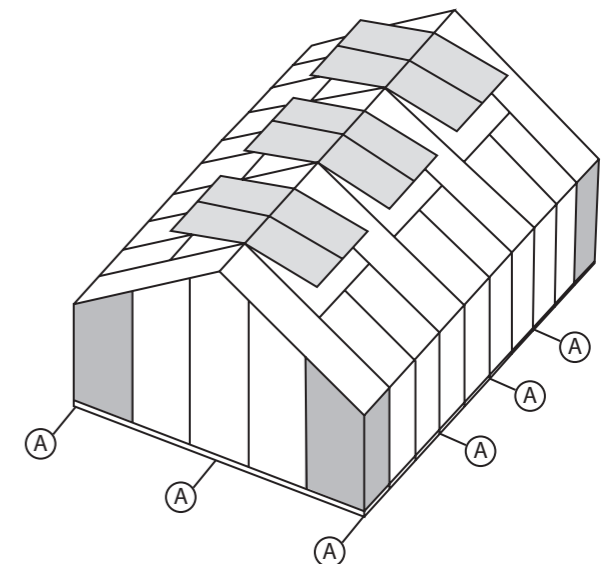
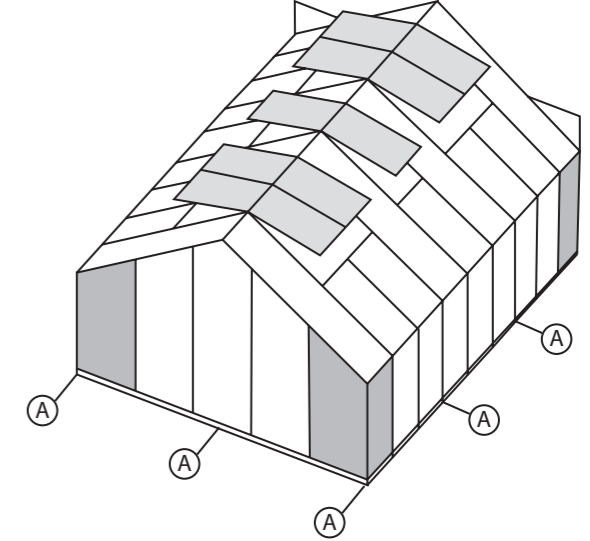
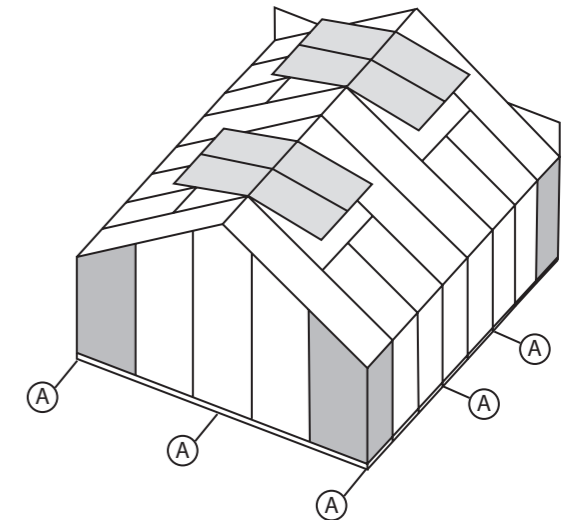





Plan ahead

If you have ordered **integral shelving** for your greenhouse, you should now slide additional fixings in the channels. Please read separate shelving instructions for more details.

Construct the sides

You will need...

LP1		Base side	2xR72/*
LP1		Eave	2xR08/*
RS		Glazing bar	R05/2*
LP1/ LP2		Side/roof stay	4xR33/1
LP1/ LP2		Anchor	R93/54*

From the Nut and bolt fixings pack

LP1/LP2	M6x11 bolt	R90/19
LP1/LP2	M6 nut	R90/20

* after the part number, either the quantity or the part length varies with the greenhouse size – check the parts list for details.

Plan ahead

If you have ordered a partition please refer to the PARTITION INSTRUCTIONS packed separately in the Partition box. You will need to fit some partition parts at this stage.



If you have a partition



Adding extra bolts for accessories

Method...

You will make the frame with the outside face of the frame facing down. For example, the eave bar will have the gutter part facing down as will the other parts.

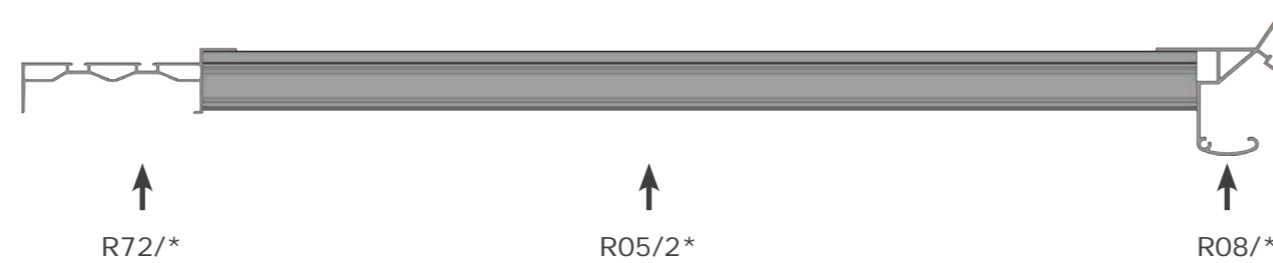

BEFORE STARTING - LUBRICATE THE M6 NUTS AND BOLTS WITH WD40 LUBRICANT OR EQUIVALENT.

The flat stays have 2 holes approx halfway along their length. Place them loosely in position and check that the bottom one of the two holes aligns with the glazing bar.

Slide extra bolts in the glazing bar channels. Each bar needs at least one extra bolt for the attachment of the heavy duty eave brace (point 2 page 14). In addition slide one extra bolt in each of the end bars for the stay and three for each louvre side (in the position you have chosen).

Lay the parts out as shown right then bolt together. Make sure that the glazing bars are pushed tight against both the eave and the base. Fit the ground anchors to the side bases in the correct places for your model.

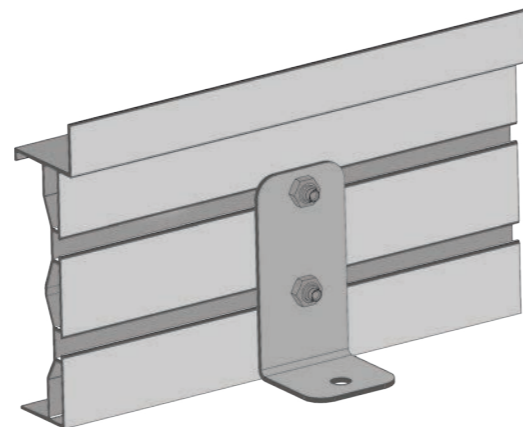

If you have a partition, make sure that you fit the partition side corners now. Please note that you will have been packed less glazing bars if this is the case. You must also slide a bolt in to each nut channel of the side bases. See drawing top right.

Bolt the flat stay to the glazing bar where they cross using the bottom of the two holes.

All 3 nuts on the stay should be left loose at this stage

If you are fitting integral staging DO NOT fit the side/roof stays.

Extra bolts for partition

This finished side is from a 10ft model

10ft

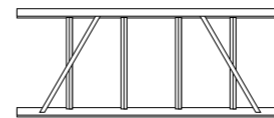

12ft

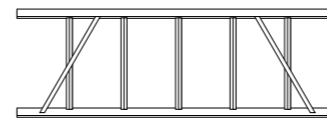

14ft

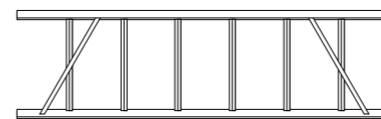

16ft

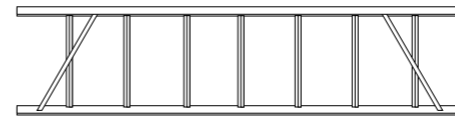

18ft

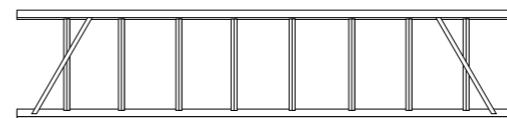

20ft

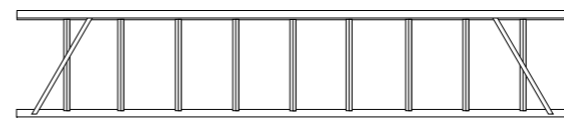

Check & tick before moving on...













- That each glazing bar is pushed tight against both the eaves and the base.
- That you have tightened all nuts except for those on the stays (R33/1).
- That you have slid extra bolts in the glazing bar channels for the eave braces and louvres. You will fit these later.
- That you have fitted the ground anchors.
- Have you added extra bolts for integral staging & shelves?
- Have you fitted your partition corners (but only if you've ordered one).
- Have you slid extra bolts in to the side bases - only if you have a partition
- If you are fitting integral staging DO NOT fit the side/roof stays.
- That you lubricated the M6 nuts and bolts with WD40/equivalent

Well done! When you have completed both sides you can move these out of the way and move on to construct the rear - see the next section.

Construct the rear

1st of 2 pages

You will need...

EP		Base rear	R72/10
EP		Top stay rear	1xR32/41
EP		End stay	R33/2
EP		Corner side	1xR07/1 LH
EP		Corner side	1xR07/2 RH
EP		Corner roof	1xR07/13 LH
EP		Corner roof	1xR07/14 RH
EP		Heavy duty glazing bar	2xR05/1
EP		Heavy duty glazing bar	2xR05/3
EP		Base corner anchors	2xR93/55
LP1/ LP2		Ground anchor	1xR93/54
From the Plate fixings pack			
EP		Eave plate	2xR91/3
EP		Ridge plate	1xR91/4
From the Nut and bolt fixings pack			
LP1/LP2	M6x11 bolt		R90/19
LP1/LP2	M6 nut		R90/20

Plan ahead

We have spread this section over 2 pages. Carefully study the diagrams on this page before continuing with laying out the rest of the parts on the next page.

If you have constructed a greenhouse before, please pay special attention to the drawing on the right. The corner sections on a Rhino are fitted in a very different manner to other makes. The eave and ridge pass through slots in the corner section and bolt on the outside, this gives the Rhino more rigidity than conventional greenhouses (this can be seen in the drawing, top right on page 12).

Just as with the sides you will make the frame with the outside face of the frame facing down. You have already used some of these sections so we will concentrate on the corner section.

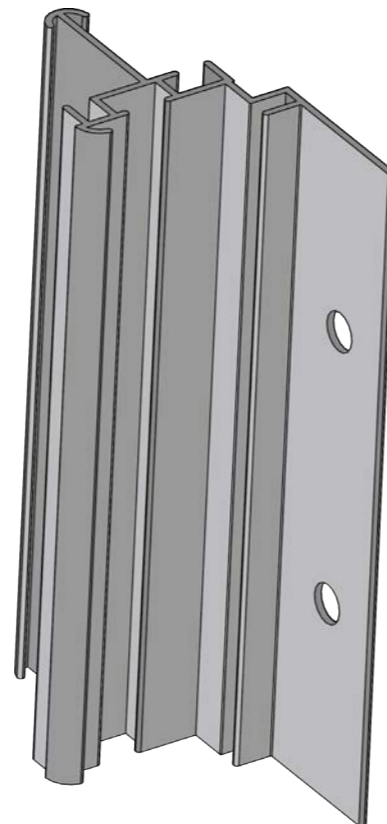

This is the corner section.

The drawing above, may look as though you are viewing the inside face of the corner section. In fact it is the outside face you are looking at.

You have to get the corner sections the right way round at this early stage so have a look at the illustration below to make sure you have set them correctly.

Lay the corners this way up when you lay them on the ground to start construction. Refer to the large drawing on page 7 for the layout.

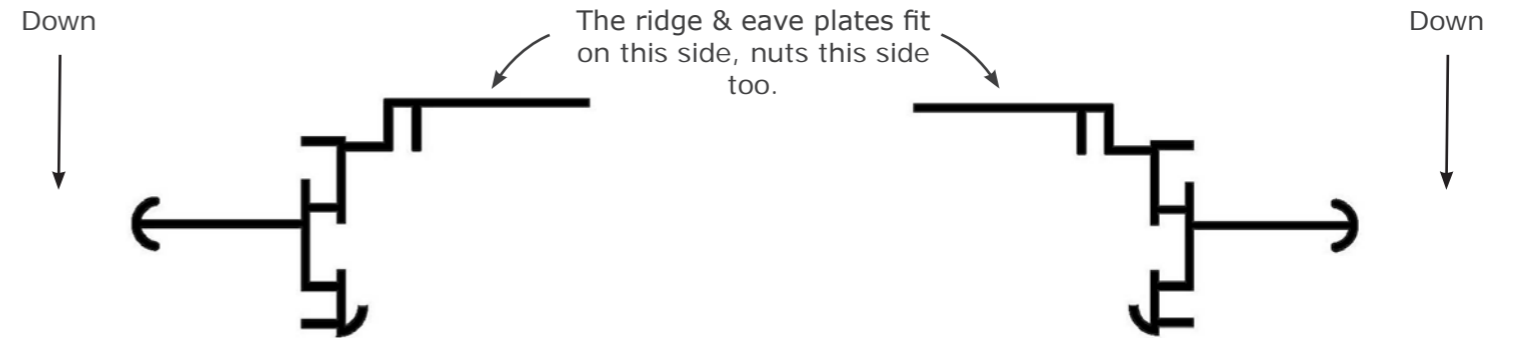

Method...

Lay the parts out as shown on page 9 then bolt together. Leave the bolts loose on the eave and ridge plates.

The corner side profiles are cut square at both ends. The corner roof profiles are mitred at one end. Mind you don't get them muddled up. **The mitred end fits at the ridge.**

Note that the bolt is always on the outside and the nut on the inside of the frame.

Remember to slide extra bolts to the appropriate glazing bars if you have chosen to fit a louvre at the rear of the greenhouse or have integral staging.

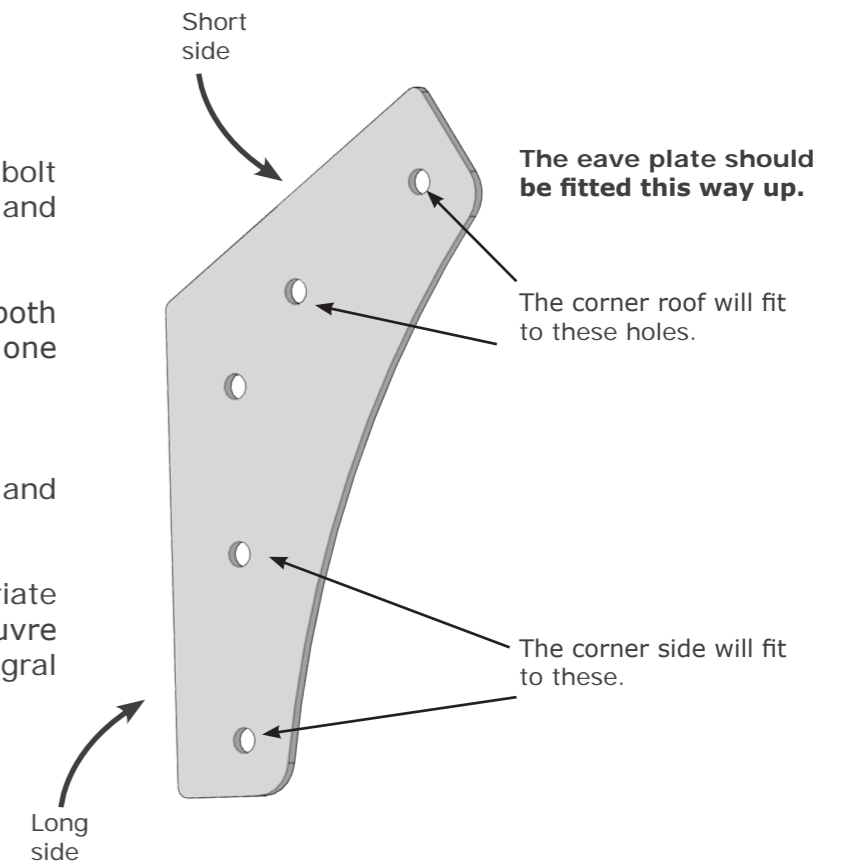

Continued on the next page...

Construct the rear
2nd of 2 pages



Eave and ridge nuts and bolts

Viewed from inside

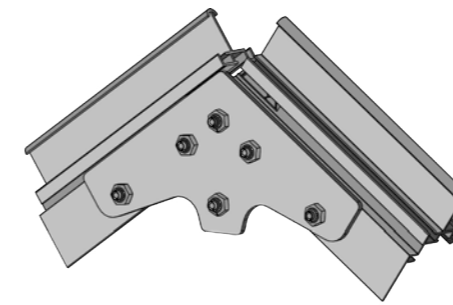

Finally...

When you have constructed the rear frame turn it over and fit 1 nut & bolt in the bolt channels (six in total) ready for when the sides are all to be connected together (stage 2 page 12).

Fit these as shown and tighten so that they stay in place.

Their positions are shown in the main drawing by this '*' symbol and arrows.

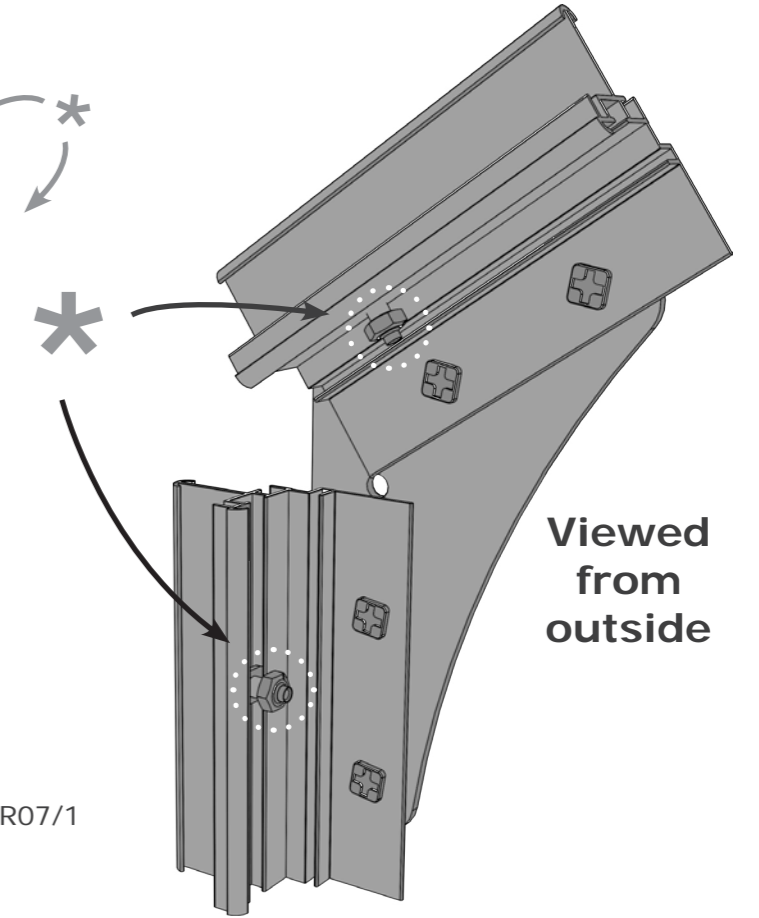
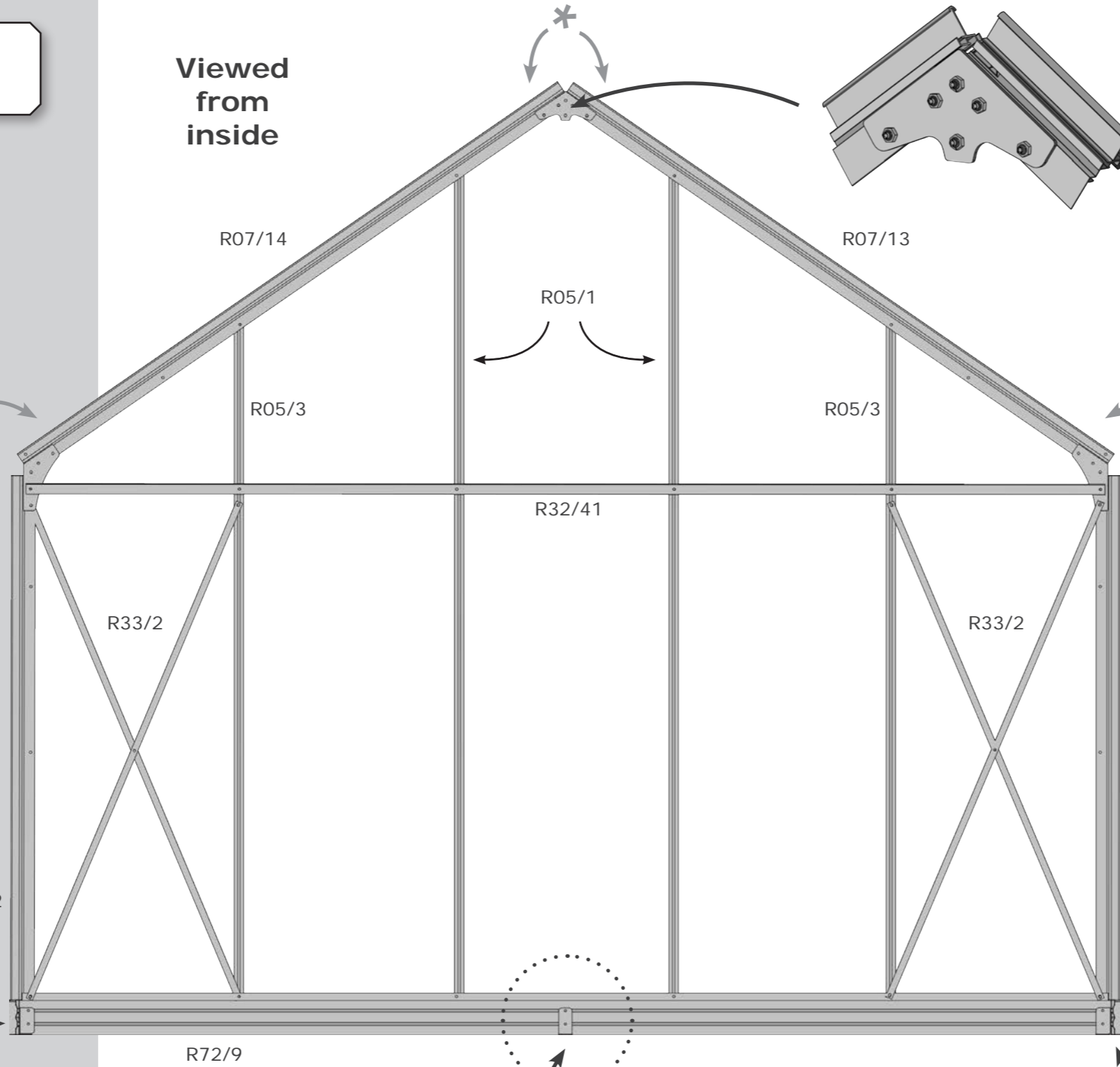
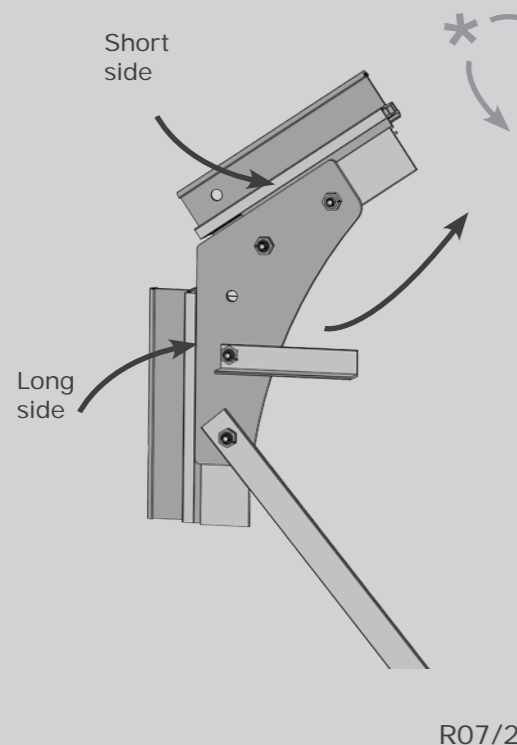

Viewed from outside

Fit the corner anchors R93/55 & leave loose.

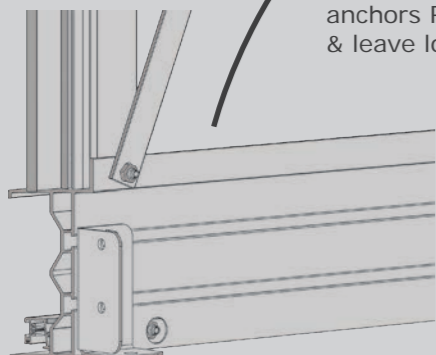

R93/54

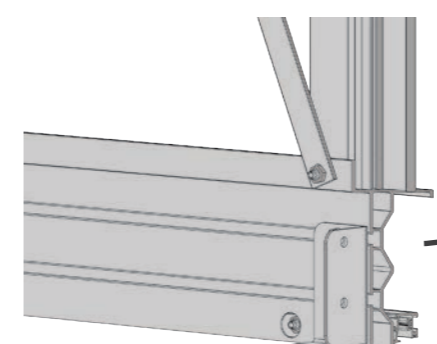
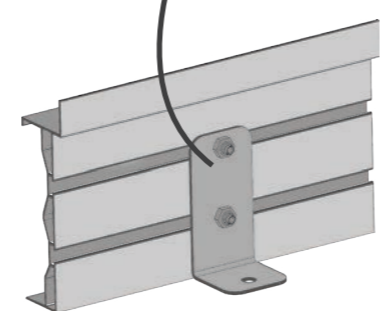



















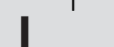

Check & tick before moving on...

- That nuts have been left loose and that you have fitted the 6 nuts and bolts at the ridge and eaves. All nuts must be fitted to the inside of the frame.
- That you have slid extra bolts in the glazing bar channels for the louvres (if you are fitting in the rear) and for integral staging.

Construct the front
1st of 2 pages

You will need...

EP		Base Flush Door end LH	1xR72/23
		Base Flush Door end RH	1xR72/24
EP		Flush Door Guide	1xR74/5
EP		Corner side	1xR07/1 LH
		Corner side	1xR07/2 RH
		Corner roof	1xR07/13 LH
		Corner roof	1xR07/14 RH
EP		Door post	2xR71/1
EP		Glazing bar	2xR79/4
		Glazing bar centre front	2xR79/3
EP		Door track mount	1xR17/4
EP		Top stay front	4xR32/43
EP		Base corner anchors	2xR93/55
EP		End stay	4xR33/2
LP1/LP2		Ground anchor	2xR93/54
EP		Ramp	2xR75/3
EP		Wool pile (fitted)	2xR92/58
EP		Guide rail filler strip	R92/64
From the Plate fixings pack			
EP		Z Brackets	2xR93/56
EP		Eave plate	2xR91/3
EP		Ridge plate	1xR91/4
EP		Guide rail end cap	2xR93/53
From the Nut and bolt fixings pack			
LP1/LP2	M6x11 bolt		R90/19
LP1/LP2	M6 nut		R90/20
From the Door fixings pack			
EP	M6 flat nut		4xR90/46

1 As with the rear build – start by laying out the parts as shown below, but at this point do not connect the parts together. Before you bolt any parts together refer to page 11.

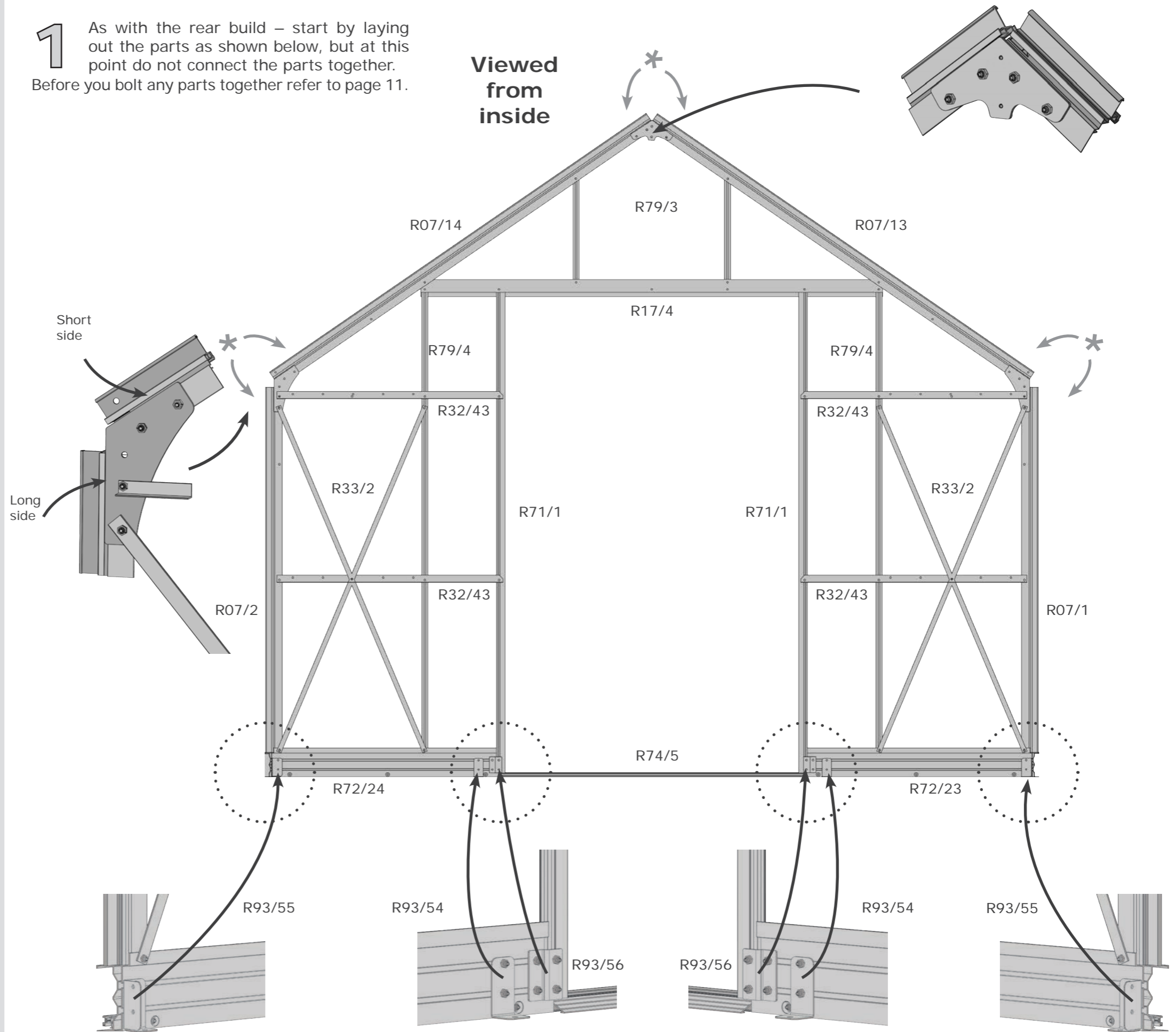

2 Start by sliding the two half ramps into the centre of the guide rail. Loosely connect the flush door bases as shown below making sure that the mitres are towards the outside, and that they are fitted hard against the ramp on both sides. Centralise the guide rail to the bases and tighten the fixings. Next secure the guide rail end caps using the fixings provided. Lastly clip the filler strip R92/64 into the guide rail either side of the outer door ramp.

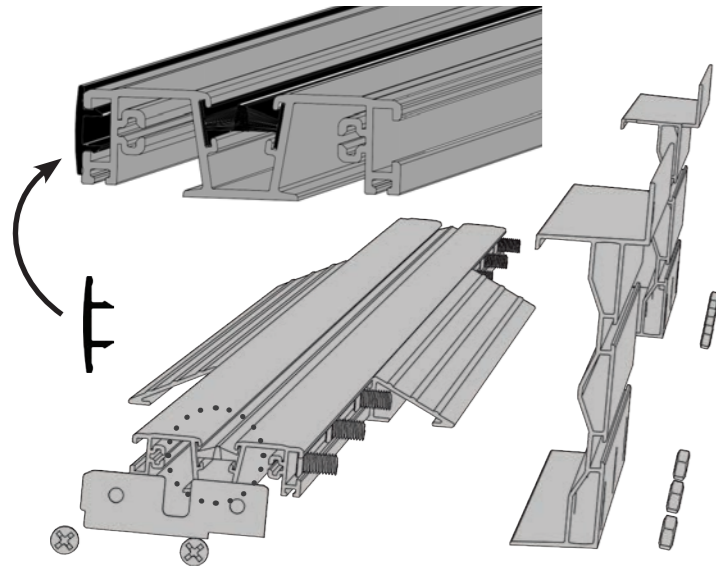

3 Connect the corner sides, end stays and base brackets to the base. Repeat for the other corner.

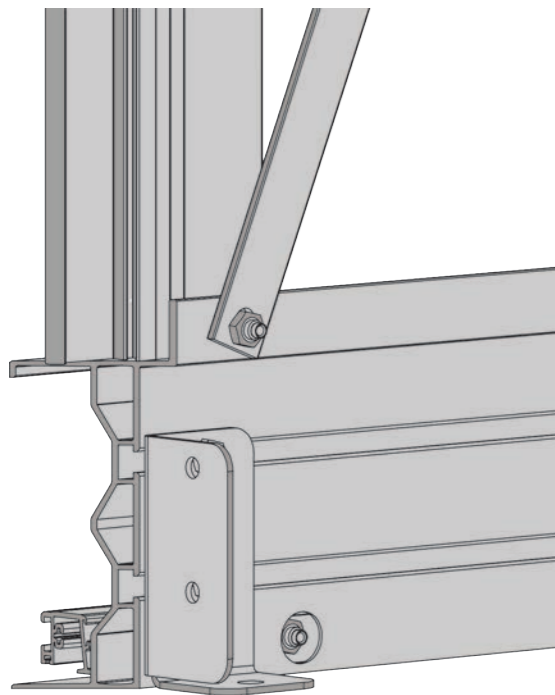

4 Slide 2 x M6 flat nut stainless steel into each door post (these will be used much later to connect the door stops), also slide 4 x M6 x 11 bolt into the door post. Slide an extra M6 x 11 for each additional integral staging (but only if you have ordered one of these optional accessories).

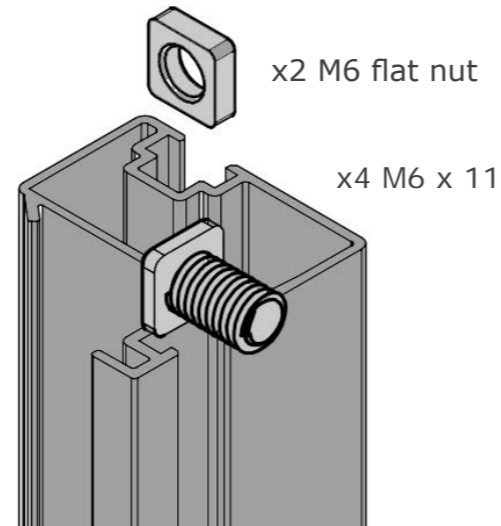

5 Connect the ground anchor as shown. Using the bottom two fixings connect the door posts to the base using the zed bracket. Use the next fixing up to connect the end stay to the door post. Repeat for the other side.

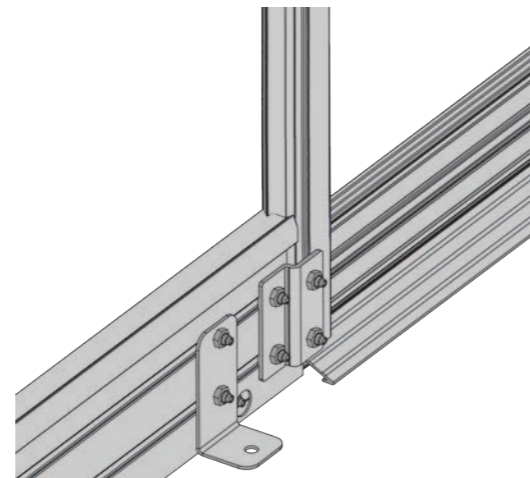

6 Connect the eave plate (refer back to page 9 if you can't remember which way up they go), top stays and end stays as shown page 9. Make sure to leave the plate fixings finger tight at this point. Repeat for the other side.

7 Loosely fit a nut and bolt into the door track mount as shown at position below.

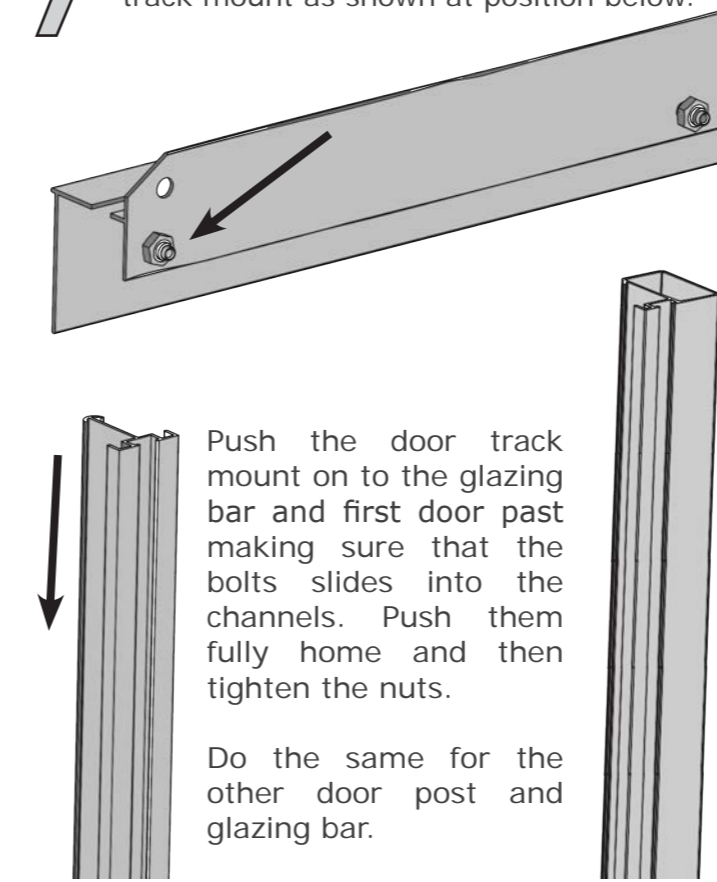

Loosely bolt the door track mount to the corner section at the hole marked below.

Do the same for the opposite end.

Leave both loose at this stage as you will need some movement in order to fit the ridge plate in task 7.

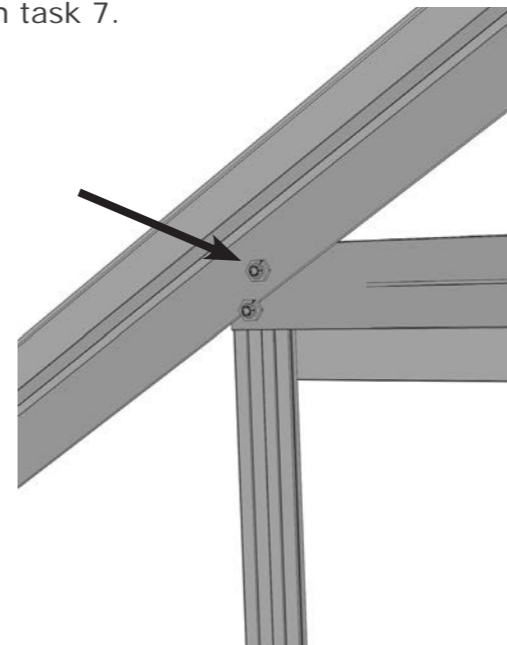

8 Connect the Ridge Plate R91/3 to the Roof Corners R07/13 and 14 and leave these fixings loose for the moment.

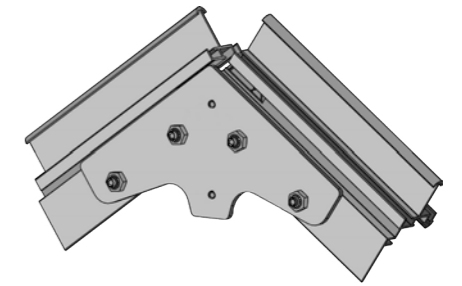

9 Insert 6 extra bolts and nuts to the corners as shown below, exactly as you did on page 9

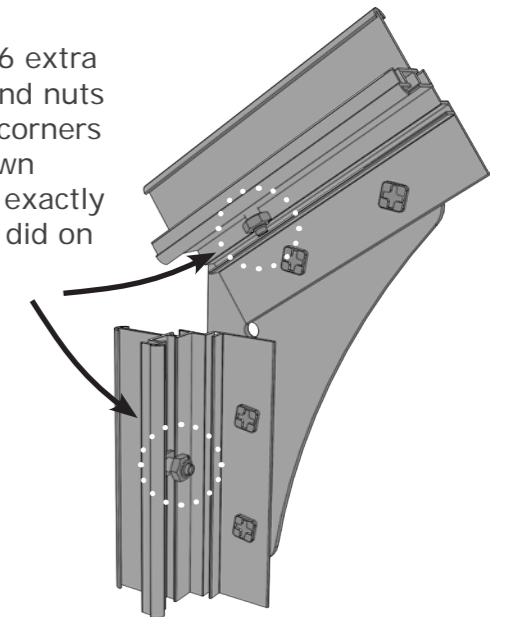

Check & tick before moving on...

- That nuts have been left loose at the eave & ridge plates but that everywhere else they have been tightened.
- That you have fitted the 6 nuts and bolts at the ridge and eaves on the outside.
- That you have fitted the ground anchors.
- Have you ordered integral staging? If so did you fit extra bolts in task 4?
- That you slid 2xM6 flat nut in to each door post.

Join the four sides



Connect the four sides

You will need...

You don't need any new parts in this section but you will need someone to hold the section upright while you bolt it to the next side.

Plan ahead

From now on most jobs will involve working with the greenhouse in its final position so if you have not already prepared and levelled the ground do so now.

It is helpful to have someone to hold the sections because the frame will be quite flexible at this stage.

1 Hold the rear end upright, lift the side into position and slide the eave section through the gap in the rear frame. This will be a fairly tight fit which is why we left the nuts loose at the eave & ridge plates. The 2 slots in the eave section should be aligned with the bolt channels in the rear corner frame (remember that you slid a total of 6 nuts & bolts in these channels earlier). Loosen 2 of these and slide the nut & bolt into the slot in the eave to secure it in position. See top right for more details.

2 Note that this drawing is of the outside of the rear section.

Before trying to connect these 2 sections, study the end of the eave bar circled here. You will see that there are 2 slots rather than holes. The nuts and bolts that you left in the end section will be loosened & slid into these slots as you can see in drawing top right.

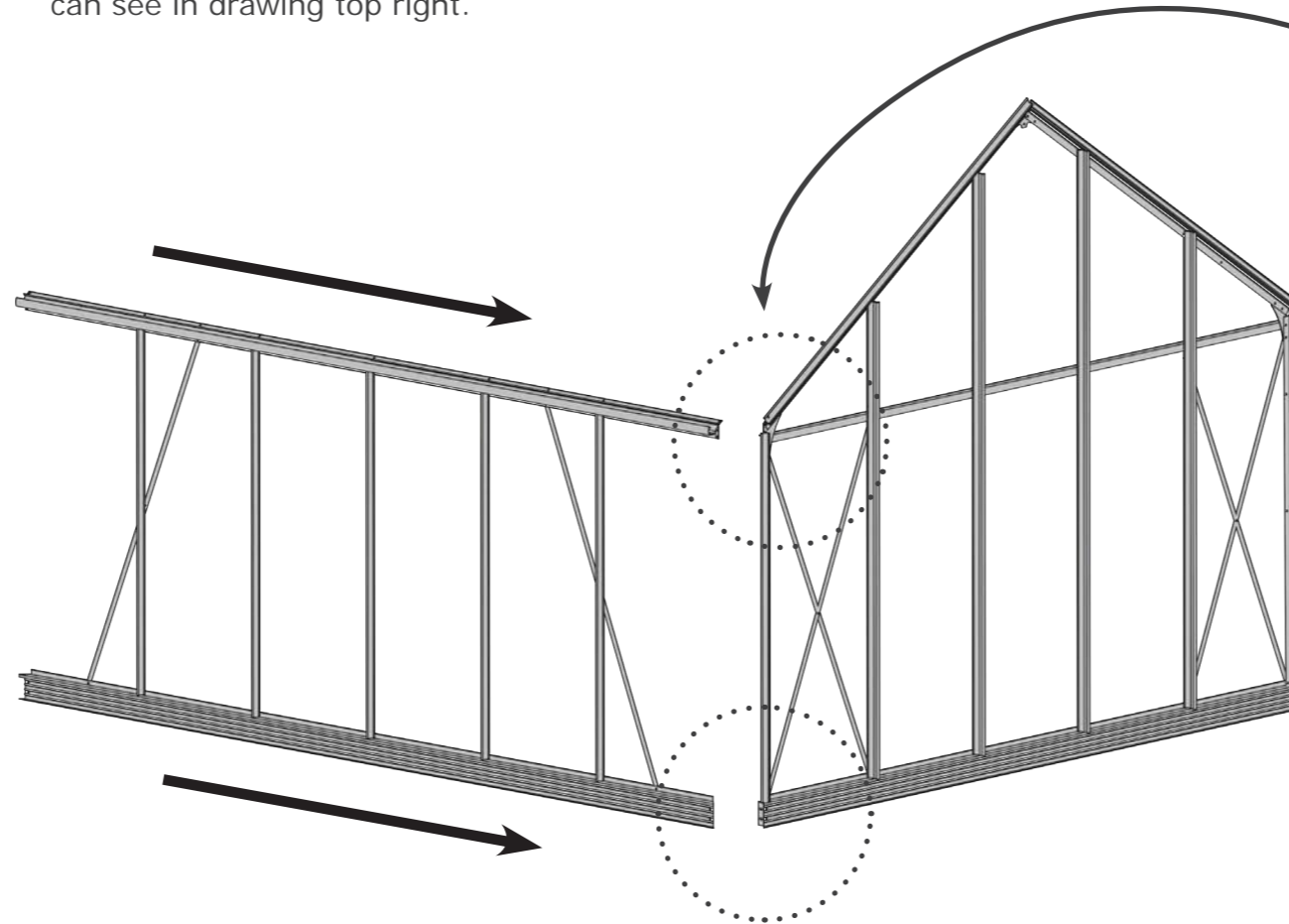

3 Bolt the base corner anchors to join the end and side frames. These can be tightened.

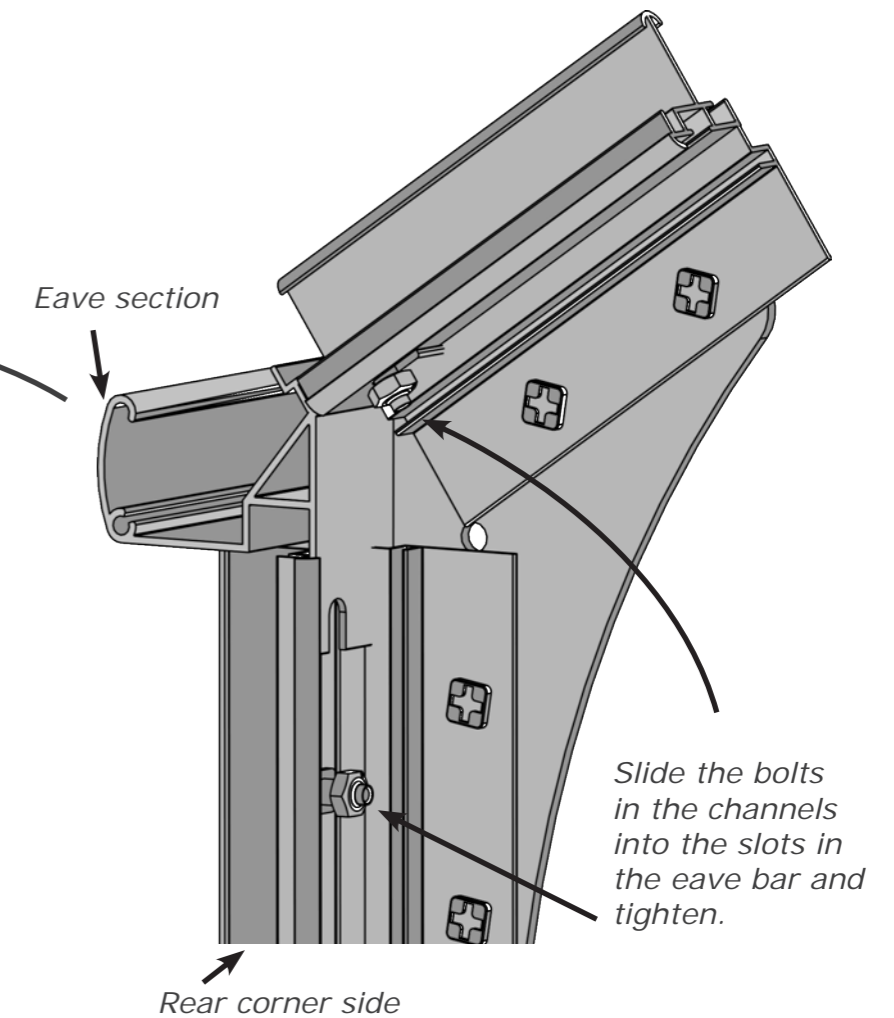
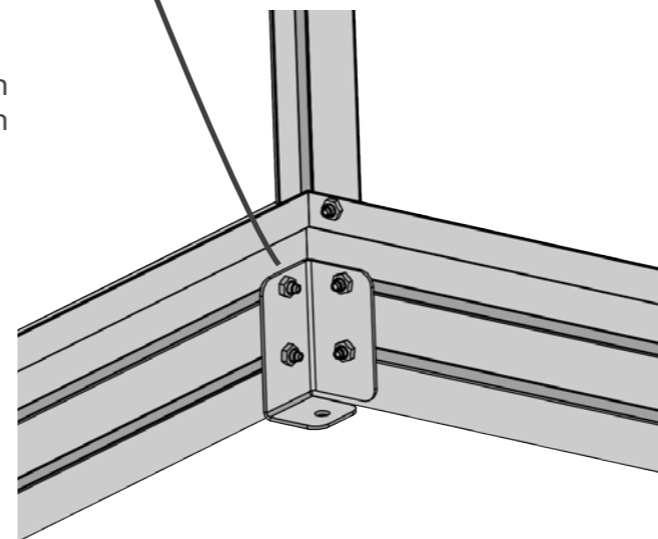

4 Repeat steps 1 to 3 for the second side and then connect the door end in the same way.

Check & tick before moving on...

- That the nuts have been left loose at the eave plates.
- That you have connected the eave section to the corners at all 4 corners.
- That you have bolted the 4 sides of the base together tightly and that the mitres are fitting snugly.

Fit the ridge & roof bars

You will need...

* after the part number = either the quantity or the part length varies with the greenhouse size –check the parts list for details.

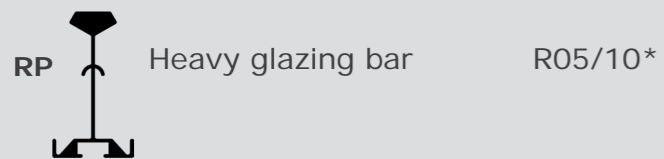
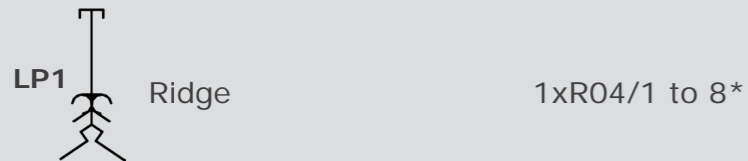

From the Nut and bolt fixings pack

LP1/LP2	M6x11 bolt	R90/19
LP1/LP2	M6 nut	R90/20

Plan ahead

You will be required to slide a number of EXTRA bolts into the roof glazing bars during this task so that they are in position for fitting the braces, hanging basket rails and roof crossbars. The drawings of the roof layout will show how many EXTRA BOLTS you need.

Don't be too concerned if you get your sums wrong as it is not difficult to quickly undo a glazing bar and slip another bolt in the channel.

If you have ordered a partition you will be fitting the partition roof corners now. Please also refer to the separate partition instructions.

1 With the ridge on the ground fit nuts and bolts to each of the holes (with the exception of the first two and the last two which are used for the roof stays). The nuts should be on the underside and left very loose. Position your step ladder on the inside of the greenhouse just at the point where the ridge will connect to the door end. It would be really useful if you could borrow another step ladder for the other end as your assistant will need to support this end of the ridge to keep it level for a few minutes.

2 The ridge fits to the front and rear sections in exactly the same way as the eave bars did in the previous section. Push the ridge bar through the gap in the corner roof sections. Secure it by loosening the 2 nuts & bolts that you slid into these sections when you constructed the ends, slide them up into the slot in the ridge and tighten. Do not tighten the ridge plate at this stage.

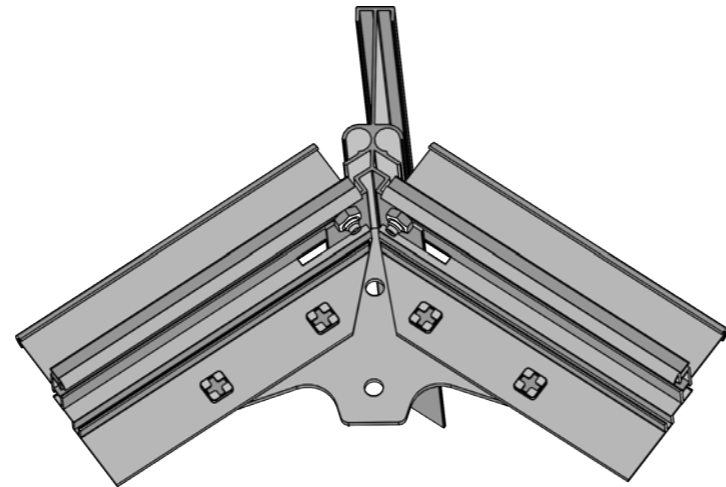

The ridge has been pushed through the corner roof bars & secured with 2 bolts.

Your greenhouse will now look like this.

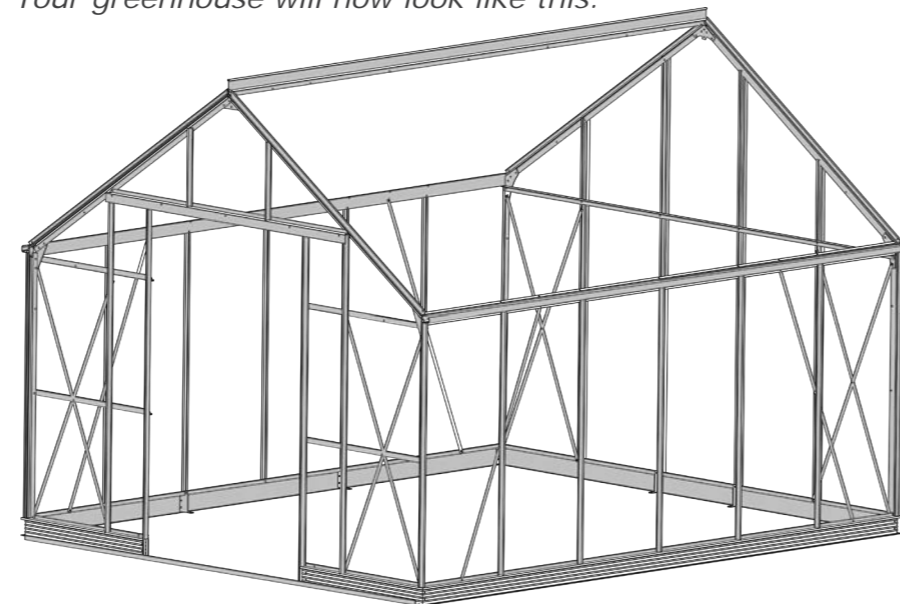

3 Begin fitting the roof glazing bars. Always start with the bars in the centre as this will take the whip out of the ridge – check the number of bolts you need to slide up the bars, this is detailed later in this section.

The roof layout varies with the size of the greenhouse. Refer to the diagram to identify the position of the vents.

Slide the bar onto one of the bolts that you fitted to the ridge in stage 1. **It must be pushed tight against the ridge and the nut tightened.**

Leave the bottom ends loose at this stage and fit all the glazing bars to the ridge.

Refer to the 6 diagrams showing the roof layout below & select your model.

Slide extra bolts into each glazing bar as indicated by the number (i.e. slide 5 extra bolts into the roof glazing bar on the first bay of a 10x14). These are the EXTRA bolts required so slide one more bolt into the glazing bar and use this to attach to the eave section.

The glazing bars must be pushed tight against the eaves when bolting into position. If a gap is left between the glazing bar and the eave then the glass will not fit correctly when the roof is glazed.

Repeat for the other side of the greenhouse.

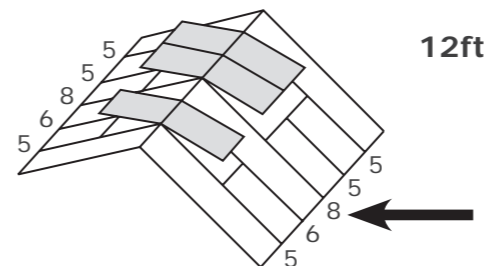
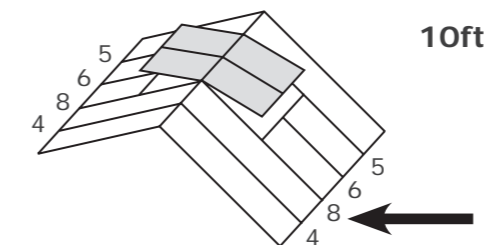
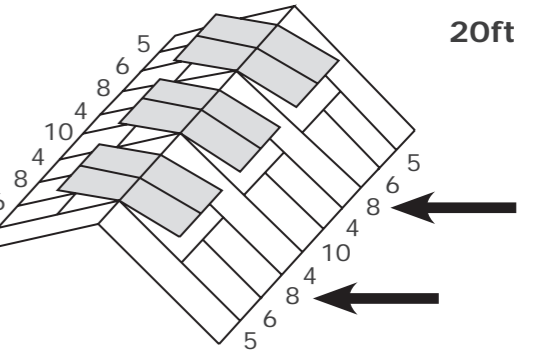
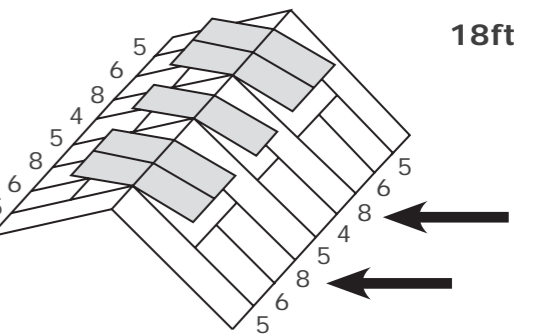
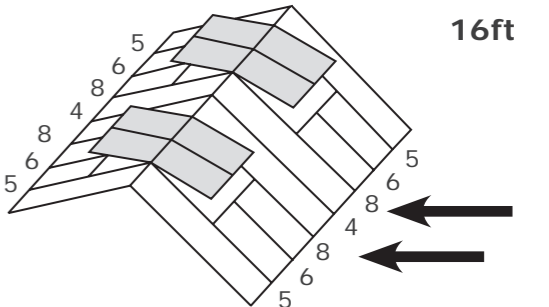
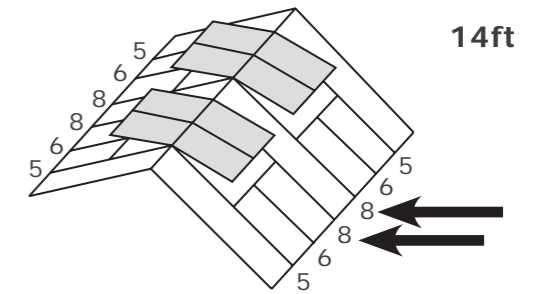

← Indicates the position where you will fit the Tie rod and brackets.

Have you fitted your partition roof corners, but only if you ordered one.

You now have enough bars fixed in place to begin fitting the vent crossbars – please see the next section.





Complete the roof

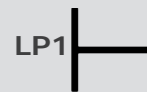

Bolts in the roof bars

You will need...

* after the part number = either the quantity or the part length varies with the greenhouse size –check the parts list for details.

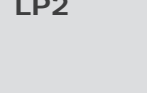
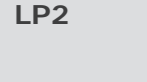
LP2		Vent crossbar This angle section has several cut outs and holes – see drawing on this page to help identify it.	R32/7*
LP1		Hanging basket rail	4xR34/22 to 27*
SP		Eave brace 360mm long	R34/20*
SP		Ridge brace 690mm long	R34/21*
EP		10ft Roof stay	4xR33/4
RP		Roof tie rod	R91/7
LP2		Roof tie rod brackets	R91/6
From the Anchor fixings pack			
LP2		M8 nuts	R90/15
		M8 washers	R90/16

From the Plate fixings pack

EP		Hanging basket rail bracket 4xR32/5 These 4 parts are 16mm long with 2 slotted holes.
----	--	--

The numbered drawing below, is of the inside of a Premium 10ft looking up at the roof. It shows what each of the extra bolts is used for. Different sized greenhouses will have slightly different arrangements but the principle is the same.

1 Fit the ridge braces (these are the longer of the 2 types of heavy "T" section brace) to the glazing bars immediately below the ridge. Start by fitting the braces from the middle out. After fitting the first brace look along the ridge and check that it is level and has not bowed downwards - if it has push it up. When you're happy that the ridge is perfectly horizontal fit the remaining braces using the first brace as a template for the rest.

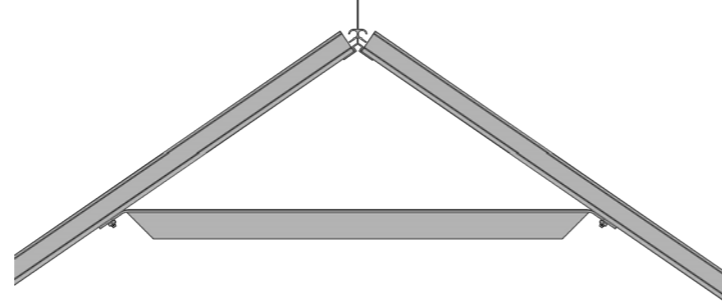

2 Fit the eave braces (these are the shorter of the 2 types of heavy "T" section brace) to the glazing bars immediately above and below the eave section like the ridge braces their position being set by the bent angle.

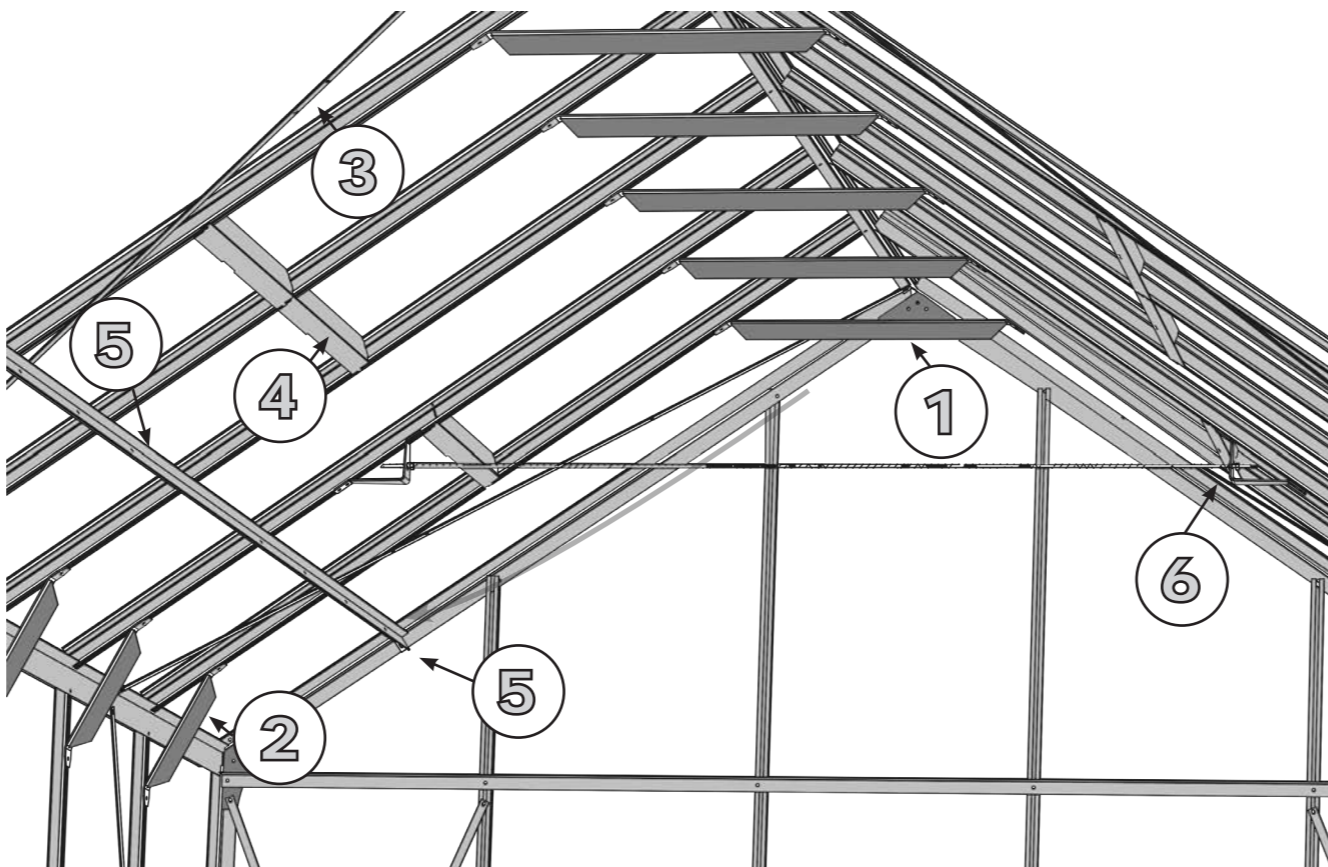

3 Fit the 4 flat stay bars diagonally to the roof. These fit to the bottom of the second glazing bar then at the ridge just in from the ridge plate. Repeat this at the rear end.

Bolt it LOOSELY to the ridge & tighten at the eave. This may well require some effort as you will be pulling the building square by fitting these braces then connect the top hole of the two centre holes to the glazing bar, again leaving loose.

4 The simplest way to fit the vent crossbars in the correct position is to take a pane G (605x903) and place it temporarily in position (see glazing plan on page 23).

Make sure that you have the crossbar the right way up (see drawing below) you will notice that each end has a cut out which will fit around the side of a glazing bar. Slide each end over the glazing bar and move it into its approximate position.

When you have fitted all the roof vent crossbars remove the temporary pane of glass for reasons of safety.

5 Fit the 4 hanging basket rail brackets to the holes in the corner roof sections.

Bolt the hanging basket rails to the brackets & then to every roof glazing bar.

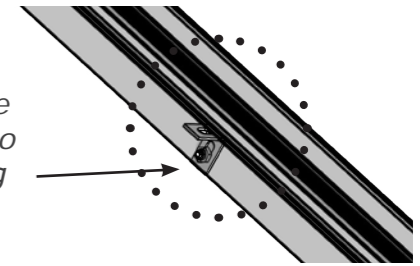

6 If the ridge sags then the eaves will bow outwards at the gutter. It is useful at this stage to use the tie rods to pull the eaves in just a shade (the ridge will then bow upwards very slightly). When the glass is fitted it will settle back to being level and the eaves straight.

With your assistant, loosely fit the threaded M8 Tie Rod to the stainless steel Tie Rod Brackets leaving plenty of room for adjustment of the nuts. Fit the brackets to the appropriate glazing bars as indicated by the arrows on the previous page.

Your Rhino may have more than one Tie Rod, if so fit them all - see below.

Each end of the tie rod is secured with two M8 nuts and washers, one either side of the tie rod bracket.

Partition

Please note the following parts will have been removed if you have a partition.

2 x R34/20 Eave brace
1 x R34/21 Ridge brace

Check & tick before moving on...

- That the nuts have been left loose at the eave plates & the diagonal braces at the eave & ridge.
- That you have fitted all the vent crossbars (4 or 12) depending on the model and that the hanging basket rails are bolted tightly.

Fit the downpipe brackets



Downpipe bracket

You will need...

EP Gutter fixing pack

Plan ahead

This section is all about preparing early for tasks you will have to do later. In the long run the greenhouse will be constructed more simply and to a higher standard if these are tackled now.

Don't be tempted to screw the frame down at this stage.

Your greenhouse is supplied with 2 downpipes which can be fitted at either the front or the rear of the greenhouse.

Have you ordered a two into one downpipe kit? If so take a look at page 28 point 8. This will explain that you may want to fit the downpipe bracket higher up the corner post.

The drawing below, shows the complete downpipe assembly and how it can fit into a water butt (butts are not supplied with your greenhouse). At this point you will only be fitting the downpipe brackets but it is vital that you fit them now as this will not be possible once glazing has commenced.

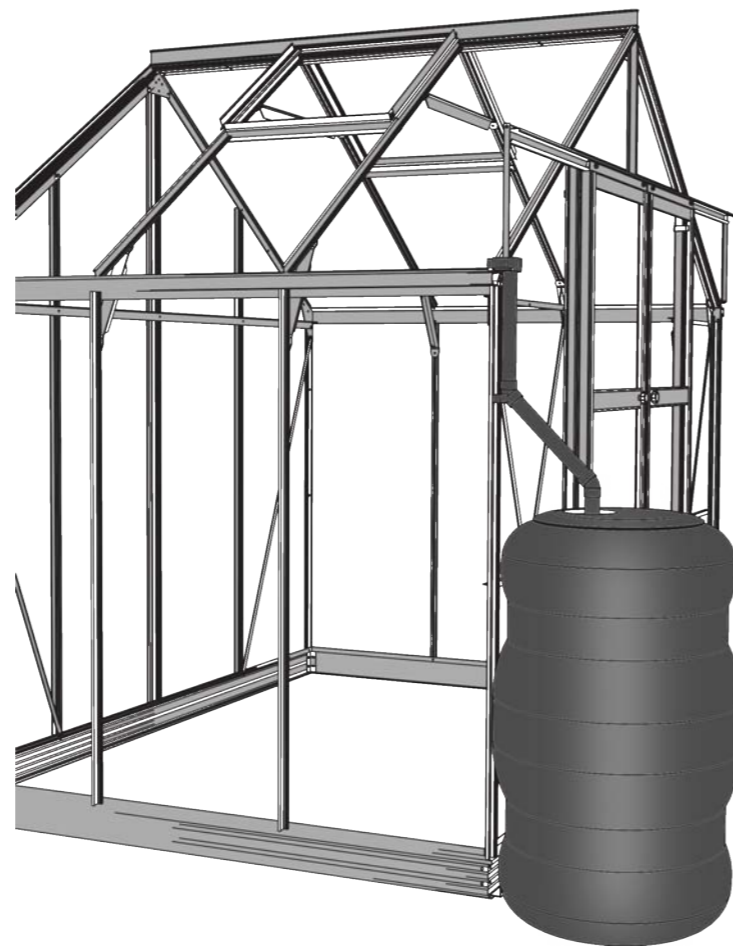

Note that the downpipe clips are offset, as shown below.

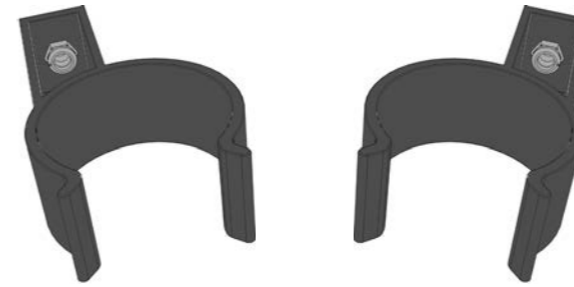

Offer up the clip to the corner bar at a suitable height (according to your own requirements) and mark the position of the hole. Drill a hole through the corner using a 4.5mm bit.

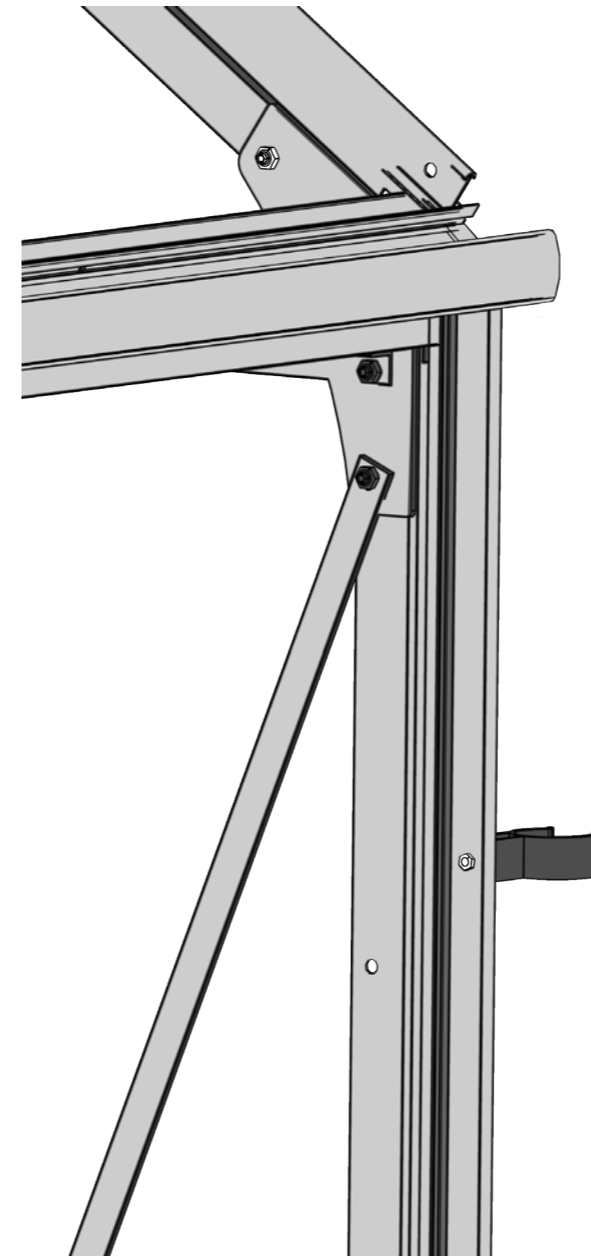

Fit the small M4 nut into the bracket as shown left. Push the bolt through the corner bar and secure the bracket. Be sure that the head of the bolt is tightened right up to the corner bar.

Do not fit the downpipes at this stage, just the bracket.

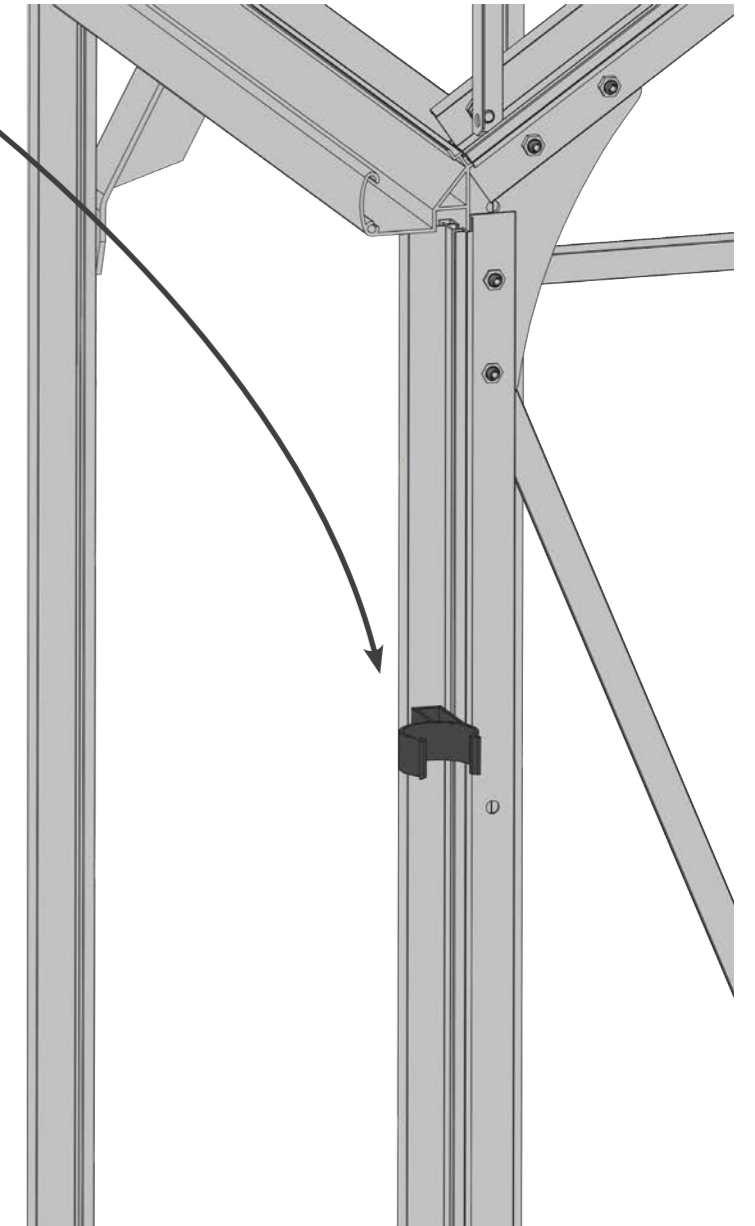

Check & tick before moving on...

- Have you fitted the downpipe brackets (this is tricky once it is glazed so make sure you have done it now).

Important Checks and adjustments

1 Have you ordered integral staging?

300mm and 600mm integral Rhino stagings are very popular. If you have ordered one or both of these please refer to those separate instructions now.

'a' indicates the approximate position of the 300 staging. The corner has been pre drilled, but if you wish to fix your integral support at a desired height of your own it is quite acceptable to drill your own hole. If you did not slide the extra bolts in when building front and rear ends, then a crop head bolt can be used in the door post.

'b' indicates the position of the 600 staging. The corner has been pre-drilled. The 600 staging, unlike the 300 cannot be fitted lower than the pre-drilled position (you can fit it higher if you wish). If you have already fitted the top stay front replace with the integral end support.

Now fit the other end support at the same height at the rear of the greenhouse.

Please note, if you haven't purchased integral staging but may wish to in the future it would be advisable to add fixings through the corner sections now!!

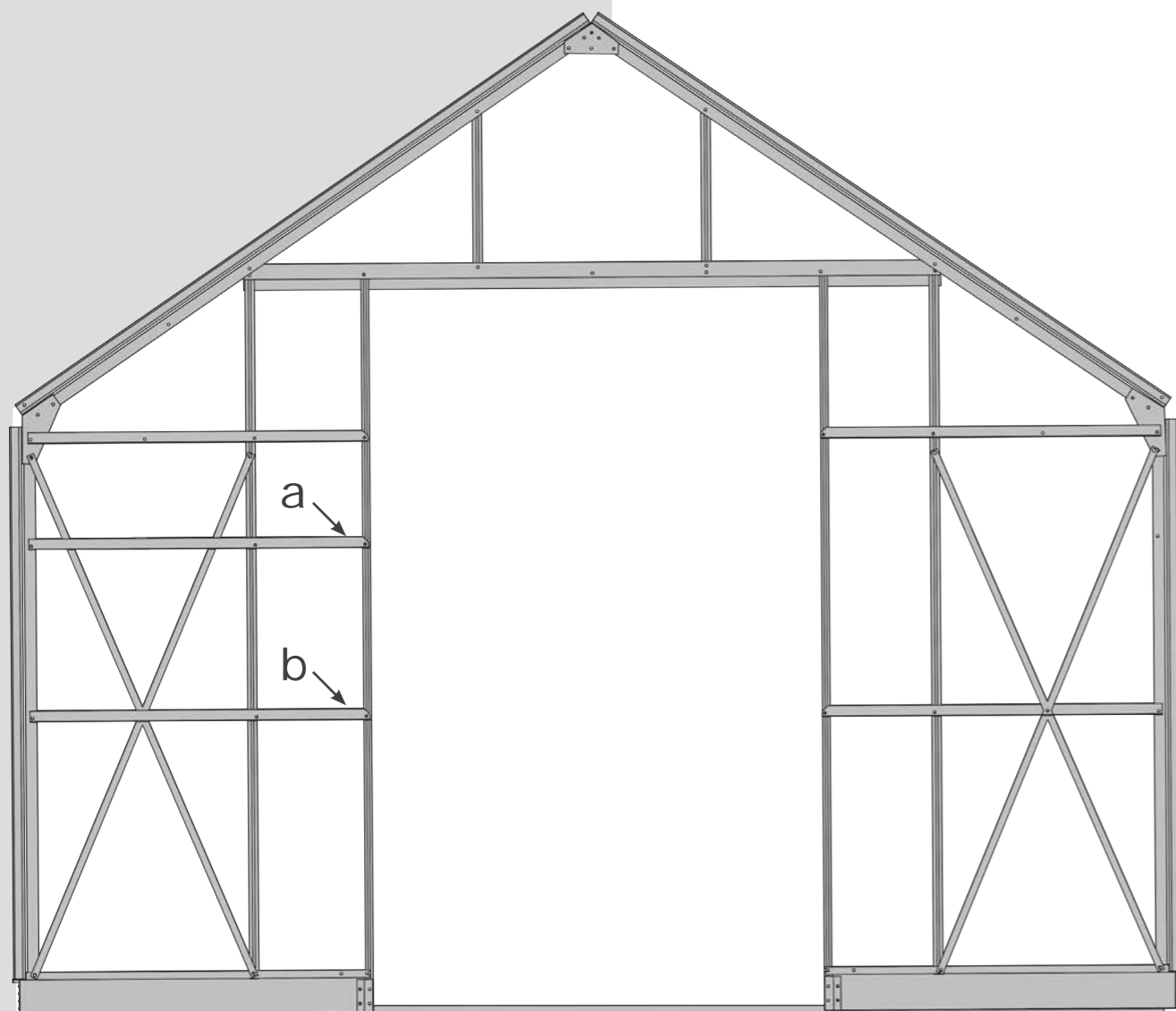

2 If your greenhouse is being sited onto soil, give some consideration now to whether the ground may settle at some future date. If this is a possibility, then take steps now to avoid any future damage occurring.

In this instance we recommend that the corners be supported under the base with a brick, block, paving slab or perhaps even a concreted area to spread the load.

Ignore this section if you are building your greenhouse on a hardstanding.

3 If you are fitting your Rhino onto soil or if you are digging holes to anchor the greenhouse then please refer back to page 3 'Before you start-Ground Anchors' Now is the best time to dig the holes and fit the "J" bolts. leave them dangling in the holes for later concreting.

Do not concrete the bolts into position, this will be one of the last jobs.

4 The greenhouse should already be level but it is important to check it again now and make any necessary adjustments.

In fact it is possible to position the greenhouse on a slight slope in order to direct the water in the gutters to whichever end you want to place your water butts. If you do decide on this then be aware that the whole greenhouse will have to lean slightly forwards or backwards as you must retain a right angle between the base and the vertical glazing bars (otherwise the glass would not fit in the sides).

In fact the gutters are fairly deep and it is unlikely that they will overflow if the greenhouse is erected dead level.

5 Check also that the greenhouse is square. Measure the diagonals across the corners.

The measurements must be equal. Another method is to fit a pane of long glass in each of the roof corners. Ensure that the bottom edge of the glass is sitting level with the eave and check to see if the long edge is reasonably parallel with the glazing bar.

If the greenhouse is not square, with the aid of your assistant you can push it into the correct position – THIS IS WHY WE HAVE LEFT THE CORNER PLATES FINGER TIGHT, SO THAT THERE IS SOME ADJUSTMENT. Be aware that one corner being a little higher than the others will give the impression that the building is not square so keep using your spirit level. Be sure to remove the glass from the corners before continuing.

When all is square & level, tighten all the corner & ridge plates **but not the eave, ridge, roof & side braces.**

Check & tick before moving on...

- With the exception of side and roof stays, (these will be tightened on Page 20 section 2) all remaining nuts should be tightened.
- Are you happy with the preparations & precautions you have made for concreting the ground anchors & preventing any subsidence at the corners?

Construct the roof vents





Assemble single roof vent



Assemble double or triple roof vent

You will need...

LP2  Vent Side R23/2

LP2  Glazing bar Centre Roof Vent R79/5

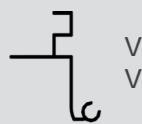
LP2  Vent Hinge single bay R24/1*
Vent Hinge double bay R24/2*

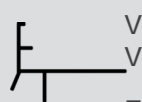
LP2  Vent Cill single bay R21/1*
Vent Cill double bay R21/2*

From the Nut and bolt fixings pack

M3 Nyloc insert SS R90/38*
M3 x 8mm screw R90/22*

* The length and quantity of the vent hinges and vent cills will depend upon the size and layout of your Rhino.

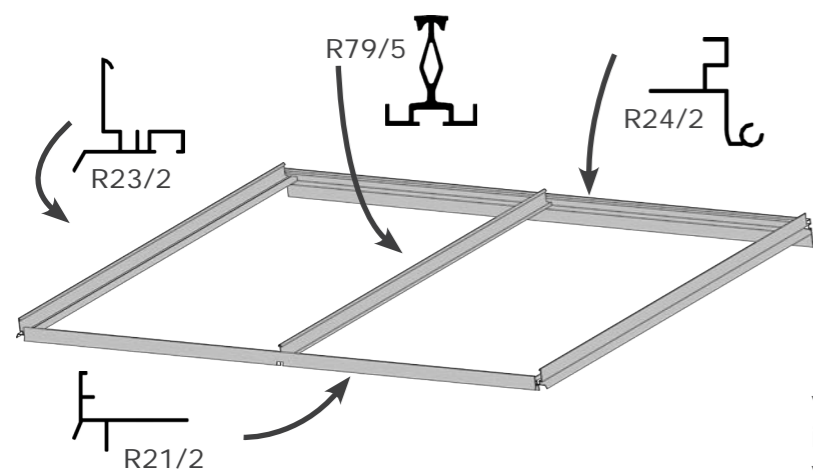

Above shows the layout of a double roof vent

1 Begin by fitting nuts and bolts loosely to the vent hinge and vent cill as shown below. Be sure that the bolt is fitted as shown or the vent sides will be upside down and it will be impossible to fit the glass correctly.

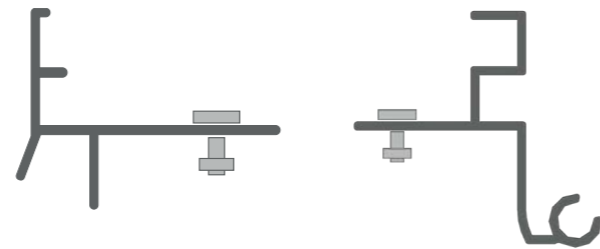

2 Slide the vent side onto the bolt on the vent cill as shown in drawing A

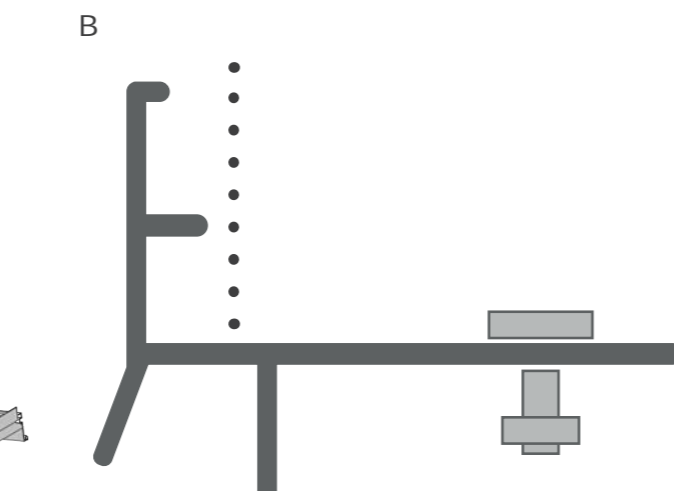
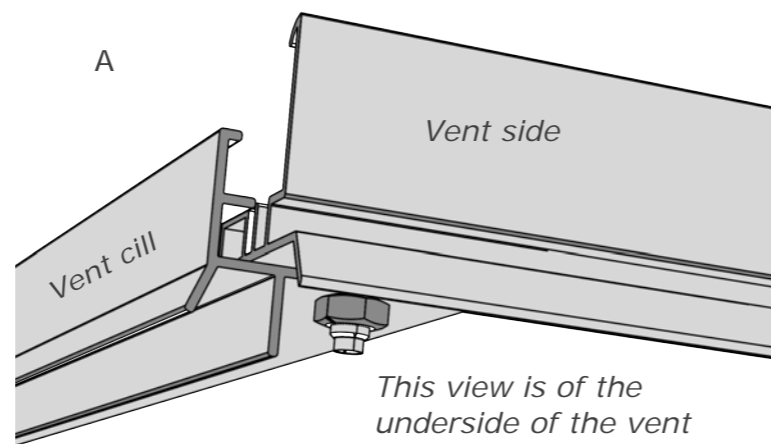

Important: note that the nut channel on the vent side should be fitted up to the dotted line in drawing B but no further. If you force it beyond this point then you will not be able to fit the pane of glass as it will appear to be a few mm too long.

3 Fit the vent hinge. You will now have a rectangle

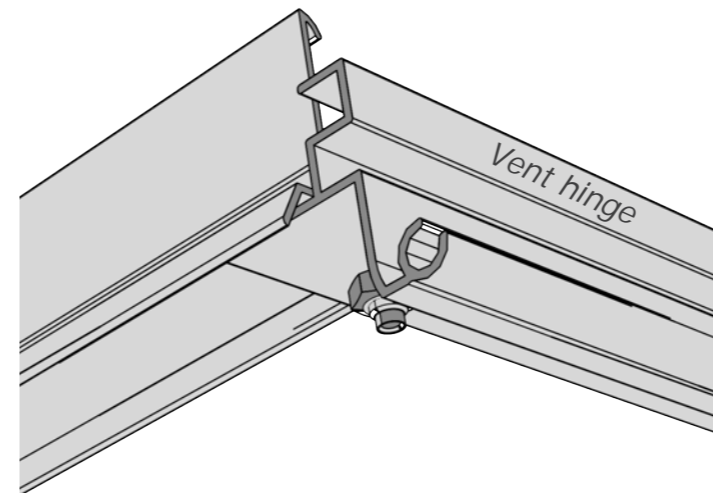

If you are constructing a single vent you have finished and can move on to page 18.

If you are constructing a double vent then you will need one vent centre glazing bar.

4 You will have noticed an extra section to the plastic bag containing the nuts and bolts which warns you to keep these small items safe. You will need these now. Please construct the next part of the vent on a flat surface such as a patio or the cardboard box so that the small nuts can be found if you drop them, they are a bit fiddly.

You will note that the drawing in section 2a is viewed from the underside of the vent. The glazing bar should be fitted to the top side.

The small bolts will be inserted from the underside through the holes in the vent hinge and cill into the glazing bar. The small rectangular nuts fit into the slot as shown below. Tighten the bolts using a screwdriver.

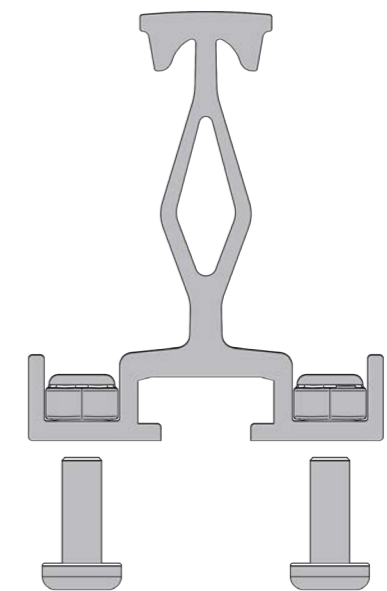



Complete the remaining frames and move on to glazing them on page 18.

Check & tick before moving on...

That you have avoided the mistake described in point two.

Glaze the windows

You will need...

- RS  Glazing rubber
- Glass – panes B 605 x 972mm
- RP  Glazing beads 1924mm R92/45

You will need a hacksaw – a junior may be best but a full size one will be quite adequate.

If space is limited or for some other reason you prefer not to glaze the windows now, just read this section and then press on with the main greenhouse.

Plan ahead

Glazing the windows now is actually a bit premature as one of the last jobs will be to slide them into position. The reason for glazing them now is that it will allow the opportunity to try out the glazing method before starting on the main greenhouse.

- 1** Start by fitting the glazing rubber to the glazing fins exactly as you did with the door.

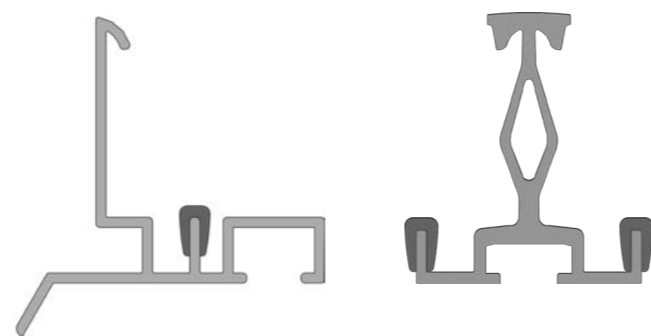

- 2** Cut the glazing beads to the length of the sides of the windows (the section shown above).

Use a new bead each time & keep the offcut OR YOU WILL BE SHORT OF BEADS!! You will need these later when you glaze the pane below the vents.

- 3** Lay the first piece of glass into the frame but be careful to get it the right way round or you won't be able to fit the beads.

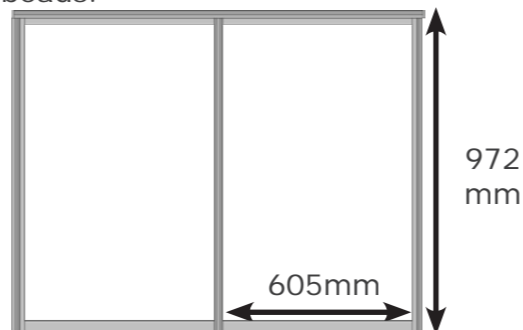

The glass measures 605 x 972mm. Slide the glass fully up into the recess in the vent hinge as in arrow A

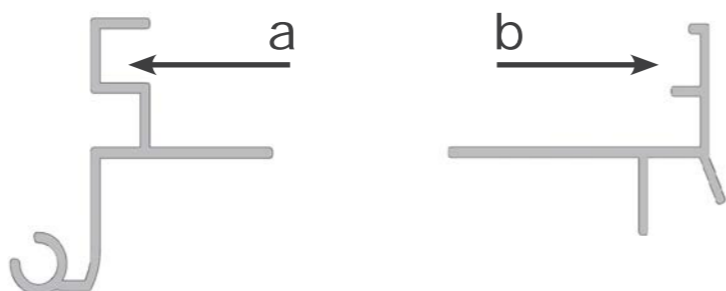

Now slide the glass back down towards the vent cill as in arrow B. This will be a fairly tight fit and you may well have to spring the frame a little to get it past the lip on the vent cill. Once the glass is in the frame, slide it fully down so that it **sits flush into the vent cill.**

- 4** Now you are ready to try the first glazing bead.

Whichever profile you are clipping the bead into, throughout the whole greenhouse it is important to note that the glass needs to be reasonably square within the frame so that the back leg of the bead has room to fit behind the glass as you can see in drawing E.

Similarly it is just as important to ensure that the glass is centralised within the glazing bars otherwise one of the beads will be loose and the other difficult to clip into place.

As a rule it is better to begin one bead off (start at one end or the other not in the middle) and then move to the other starting that off too. This way you avoid pushing the glass completely to one side and having trouble clipping the second bead in.

The soft black fin is the edge which seals against the glass. Start by tucking the other end under the lip on the vent side glazing bar as shown in C.

Now push the bead back as in D.

The back leg of the bead will tuck in behind the glass as in E.

Drawing F shows how the bead will look when clipped in.

The rest of the vents can be finished now. Don't worry about the automatic vent openers at this stage they are fitted once the windows are installed in the greenhouse.

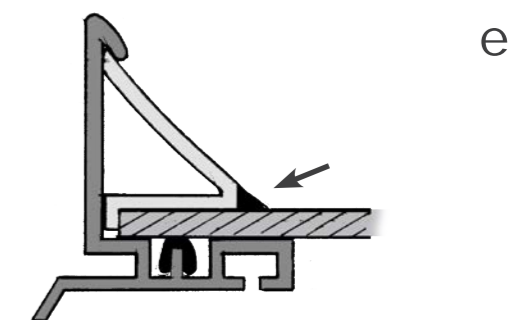
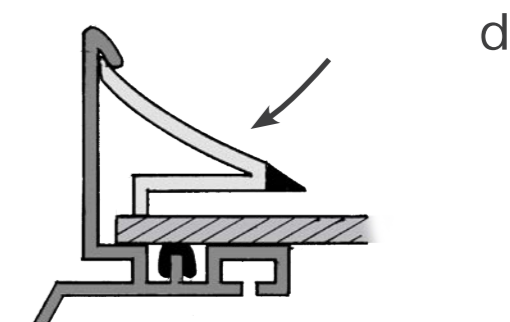
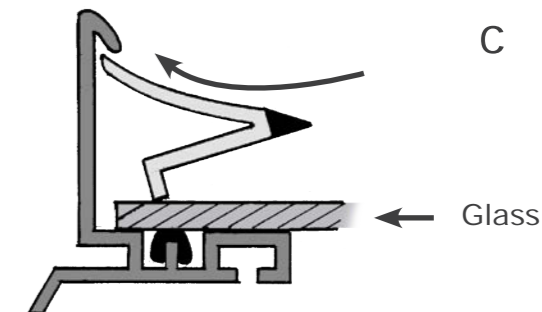
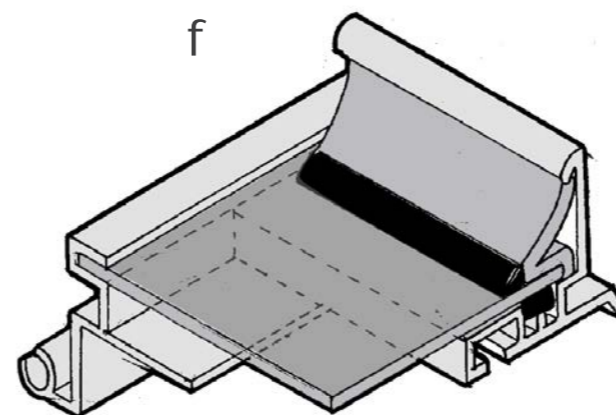







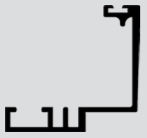

If you have a 'glazing paddle' and a rubber mallet you may find them useful here to ensure that the beads snap home. Place the end of the paddle against the soft rubber fin on the bead (see arrow) and tap it with a mallet. Be sure to tap a few inches one side then move to the opposite bead, this will keep the glass centralised.

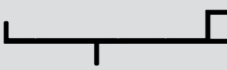
Sometimes the beads can appear stiff to fit, this is usually caused by colder conditions when installing. This can be resolved by applying warm soapy water to them before they are fitted.

Assemble and glaze the doors

You will need...

- EP  Flush door stile 3xR83/1
- EP  Flush door meeting stile 1xR85/1
- EP  Door cross-member top 2xR15/1
- EP  Door cross-member bottom 2xR86/1
- EP  Door transom 4xR16/1
- EP  Wool pile (fitted) 2xR92/57
- RS  Rubber R92/12
- EP  Glazing beads long (2347mm) R92/9

From the door fittings pack you will need:

- 4 x door knobs
- 4 x door wheels
- 4 x M8 bolts stainless steel
- 8 x M8 flat nuts stainless steel
- 4 x M8 Nyloc nuts stainless steel

Other items you will need:
Drill bit 7mm (not supplied)

Glass:
4 x E - 605x610
2 x K - 605x512

1 Start by laying the parts out as shown below. This section could be tackled at any time, so if you get a wet spell while building your greenhouse you could still be making progress by building the doors.

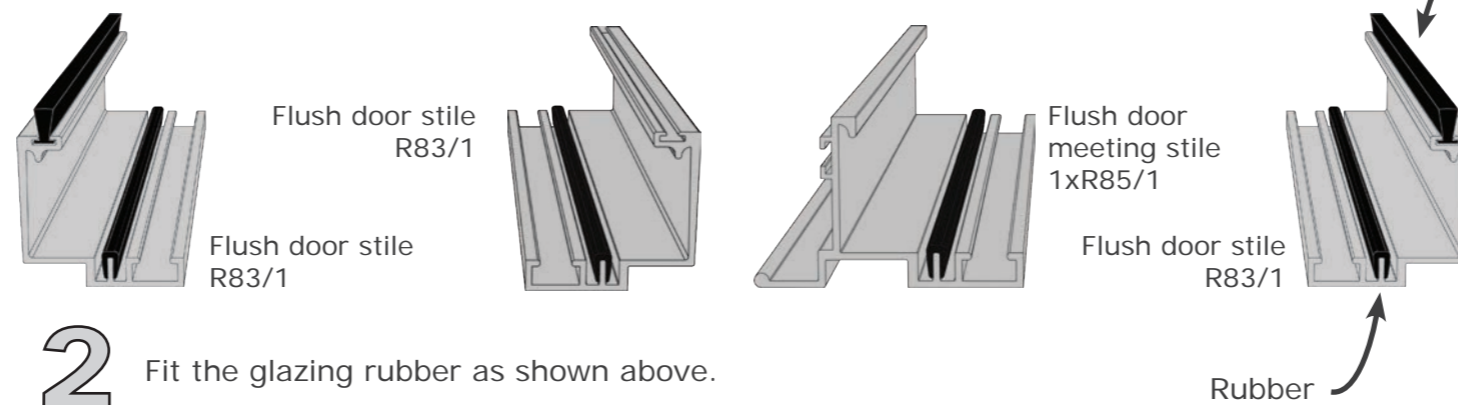
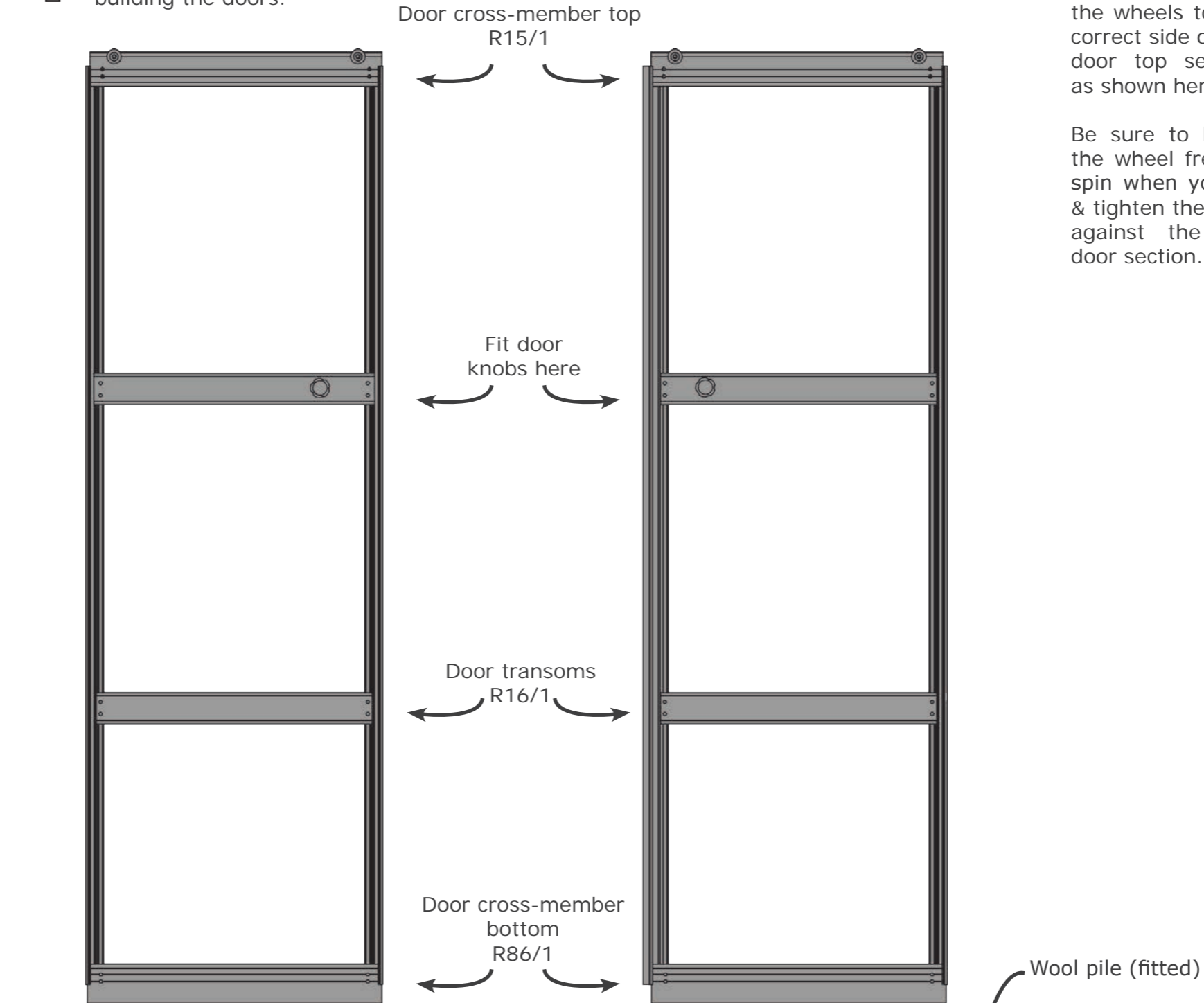

2 Fit the glazing rubber as shown above.

3 Fit the wheels to the door cross member tops using the M8 bolts. Be sure to fit

the wheels to the correct side of the door top section as shown here.

Be sure to leave the wheel free to spin when you fit & tighten the nuts against the top door section.

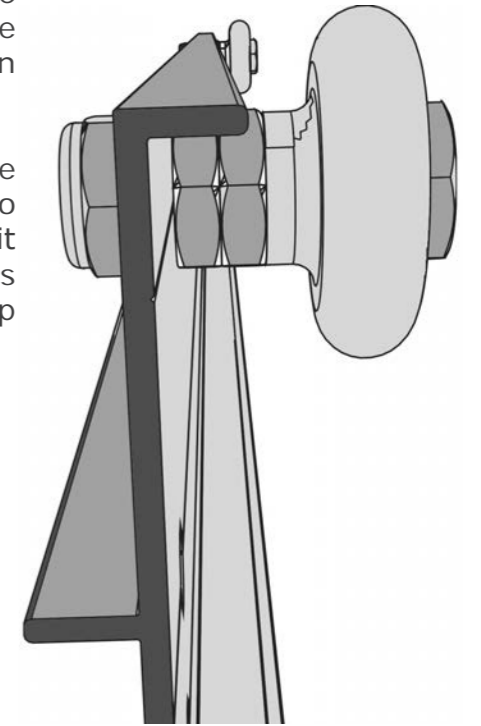

Check & tick before moving on...

- That you have fitted the rubber.
- Are the door wheels held securely whilst still turning freely?

4 Bolt the top door section to the door stiles and tighten the 4 nuts. Be sure to push the stiles right up to the stop as shown by the arrow A (right) otherwise the door will end up the wrong length.

Fit the transoms (right) approx 620mm below the top door section but leave the nuts loose.

Note that pane E is fitted here with the 610mm edge running vertically along the door stiles.

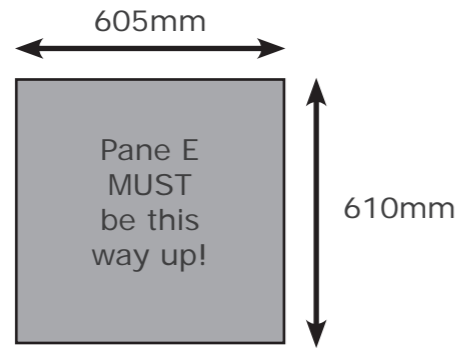

Take glass pane E (605X610) and push the longer 610 mm edge up into the "U" groove on the top door section (as shown by arrow C right). Slide the transom up to the glass and ensure that it is pushed fully home.

Now you have fitted the first pane of glass, the rest of the door can be finished in the same way.

Fit pane K (605x512) as the centre pane and bolt the transom into position exactly as before.

Do the same for the bottom pane E. Fit the bottom door cross-member making sure its pushed hard up to the door stile as shown by arrow D.

Repeat this for the other door.

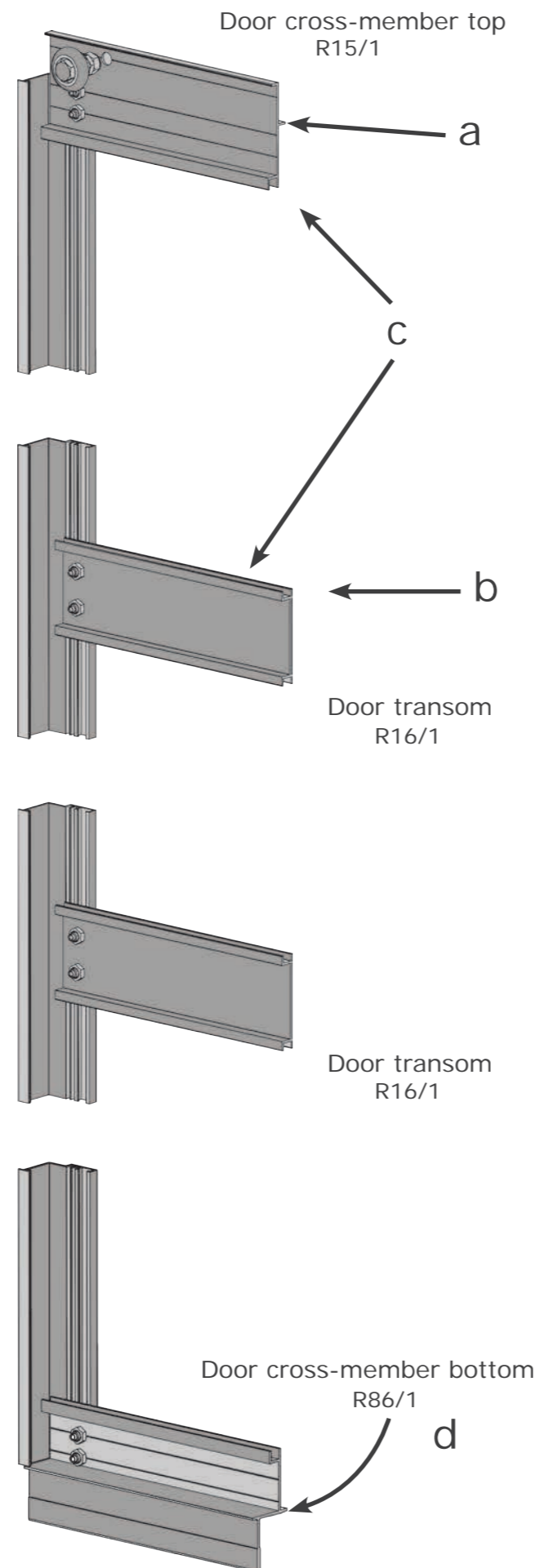

Finish the doors

5 FITTING THE GLAZING BEADS

Before fitting the glazing beads, ensure that the doors are square and that the glass is centralized between the door stile sections. Refer back to page 18 point 4 as a reminder of the method.

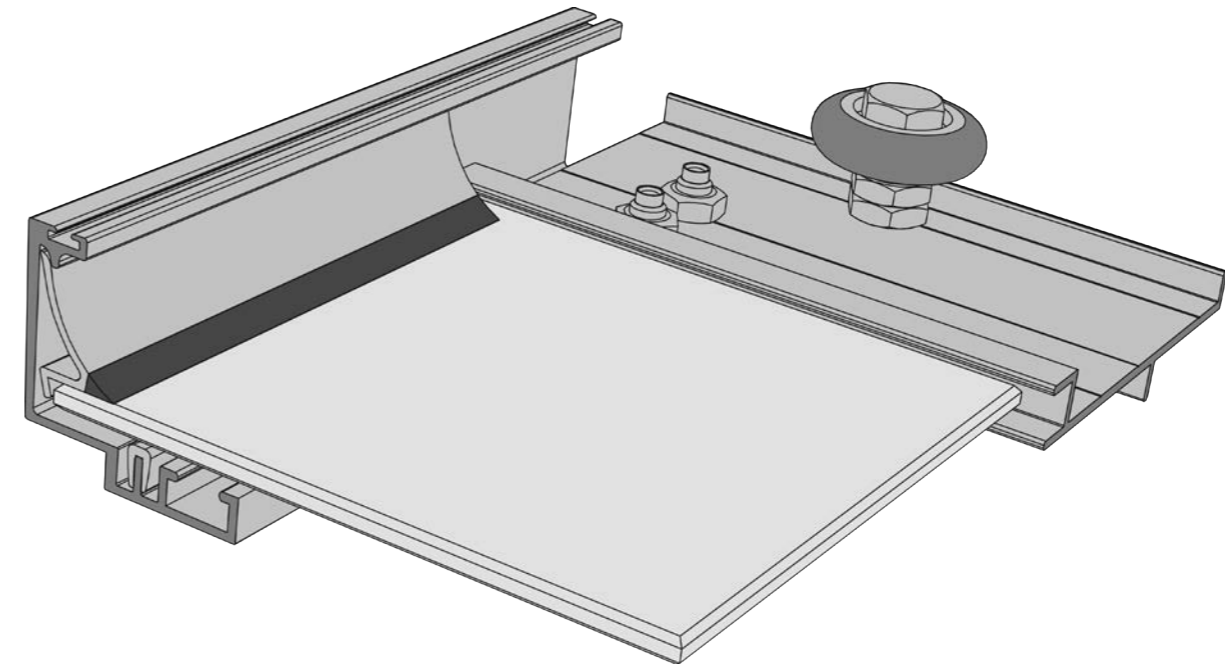

6 FITTING THE DOOR KNOBS

Drill a 7mm hole in the higher of the two door transoms at a convenient point as shown below. Screw the male and female handle together.

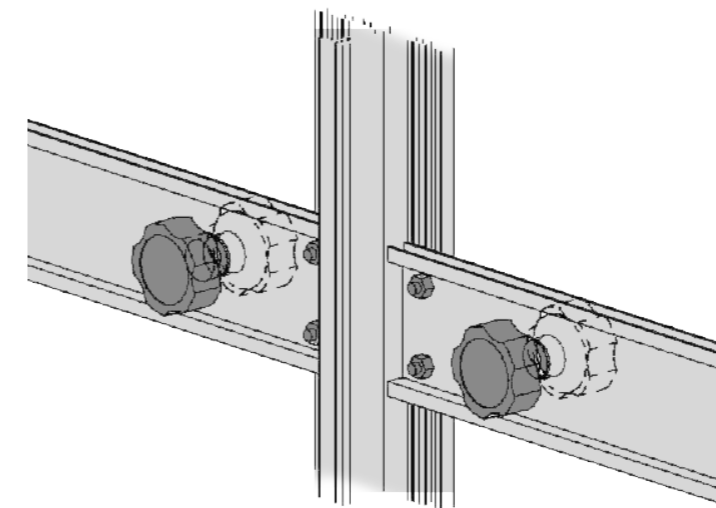

Check & tick before moving on...

The door wheel is free to spin

Prepare for glazing

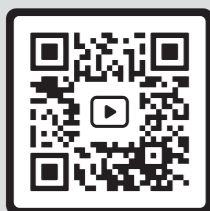

Louvre



Automatic louvre opener

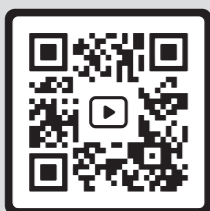

Weigh the greenhouse down

You will need...

From the Nut and bolt fixings pack

2 x M6 x 22 R90/2
6 x M6 nuts R90/20

RS  All the glazing rubber R92/12

LP2 Louvres R93/2

SP  Glazing beads medium R92/8

1 Fit an M6x22 bolt to both the LH & RH front roof corners (as shown below by the arrow), ready for the door support stay which will be one of the last jobs.

The bolt head must be on the side of the bar where the roof glass will be with the nuts on the front of the greenhouse. Fit 3 (yes 3) nuts.

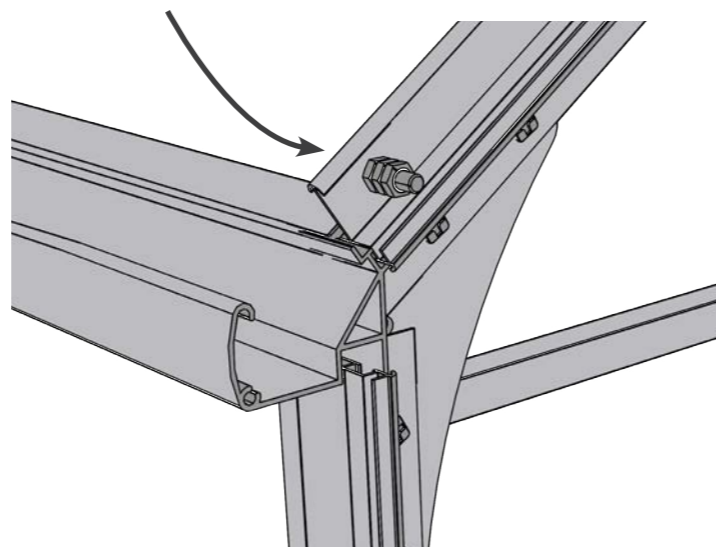

2 Fit the glazing rubber.

Having glazed the doors & windows you will be familiar with the fin that the rubber attaches to. Every profile to be glazed has this apart from the horizontal ones where rubber is not required. Fit the glazing rubber to the rest of the frame.

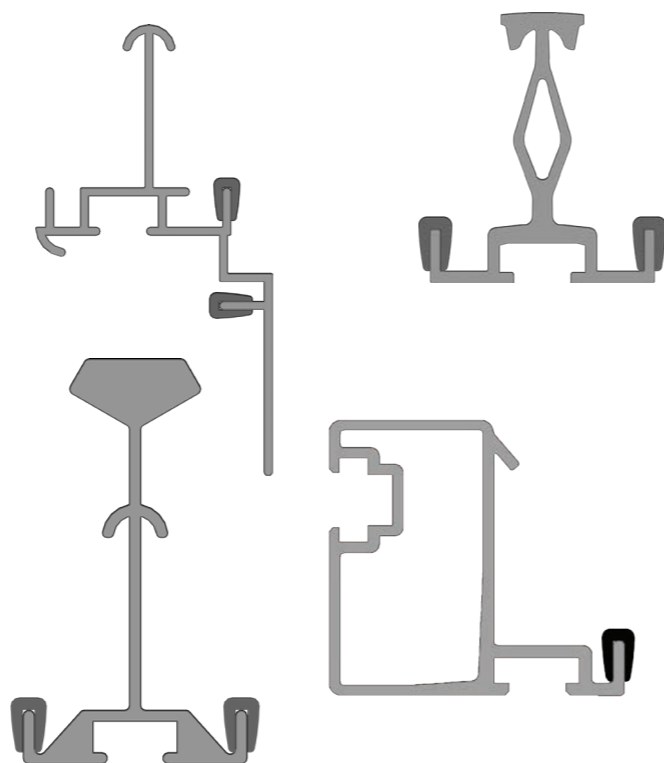

The following do not need rubber:

Glazing bars above the vent crossbar where the windows will fit.
Vent crossbar, Eaves, Ridge, Base.

3 Fit the louvre frames.
Back on Page 6 where you chose to draw them.

Each louvre consists of 2 parts, a right hand side which incorporates the handle & a left hand side which has no handle.

These are designed to fit in any bay on the sides or rear of the greenhouse except next to a corner bar.

If you are fitting your louvres in the sides of your greenhouse select 2 lengths of 1489mm glazing beads. Cut a piece 190mm from each. Place glass pane glass T (605x192mm) hard to the bottom of the base and secure using the two beads you cut down. Repeat this process for each louvre saving the large off cut of beading each time, this will be used for fitting the glass above the louvre. Use the longer beads if you wish to fit a louvre in the rear. Fit in exactly the same way as the side.

Before fitting the louvre sides to the greenhouse you must attach the end caps (R92/49) as indicated in louvre diagram, these are fitted at either end of the louvre frames (2 per side).

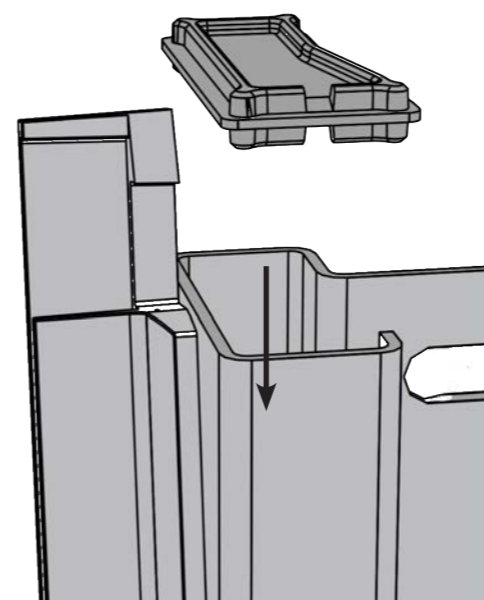

Fit the louvres sides hard onto glass pane T making sure that the louvre side containing the handle is fitted on the right hand side, this is shown in the diagram below.

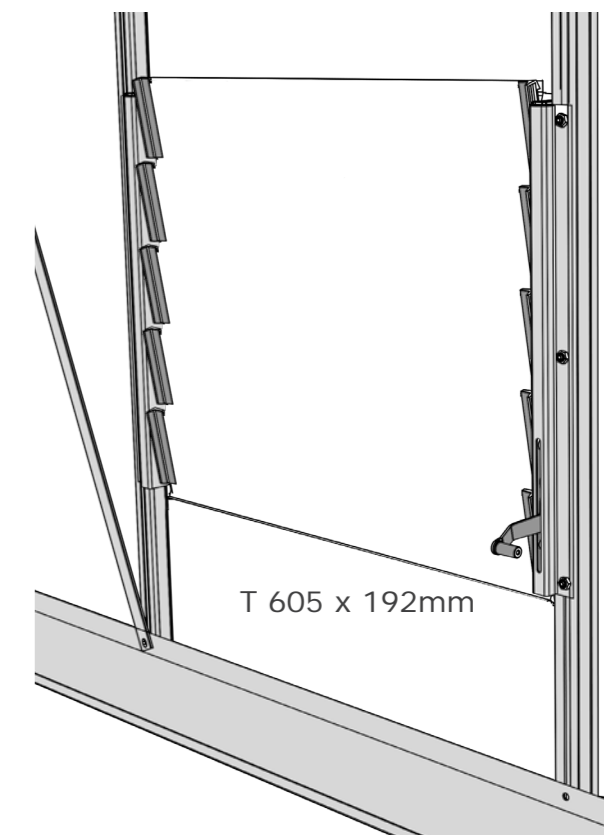

Check & tick before moving on...

- Have you fitted the M6x22 bolts?
- Have you fitted glazing rubber to the corners, glazing bar and door posts?
- Have you fitted glass pane T 192mm and your louvre frames?
- Have you fitted louvre end caps?

Partition? Then.... Glazing!

IF YOU HAVE ORDERED A PARTITION....

We recommend that you glaze the partition before the main greenhouse. No need to fit the partition door until later. Refer to the Partition Instructions, which are packed with the partition frame.

FOR GLAZING YOU NEED....

All sizes of glazing bead

EP  H section (above door) R92/14

LP2  H section glass joint R92/16

From the door fixings pack

EP  Glazing clips 'W' R91/5

At least one assistant, a sturdy and fairly tall stepladder, a hacksaw (a small one for preference but any size will suffice) & safety goggles.

A glass sucker is useful but not essential.

SAFETY ISSUES

Being toughened, the glass is a lot safer and easier to handle than the normal horticultural glass – you will notice for example that the edges are not sharp & of course, it will take a much harder blunt blow to break it.

But be aware that toughened glass has certain properties which mean it must still be treated with respect:

Toughened glass can still break, when it does it will immediately collapse into thousands of tiny pieces – this is designed to protect you from serious personal injury by avoiding long shards of glass. The small pieces are still sharp and small cuts are possible. Be aware of the danger to your eyes – especially if you are standing inside the greenhouse whilst glazing the roof. Just as you see on so many DIY television programmes - WEAR SOME SAFETY GOGGLES.

While you are moving & handling the glass be aware that the toughening process makes it vulnerable to knocks on its edges. Catching an edge on concrete or brickwork whilst carrying it can easily cause it to break. Of course, when it is installed in the greenhouse the edges are all well protected.

We hope this section hasn't alarmed you. There is no need to be worried when you know the areas to take care over.

Of course take care when working on your stepladder, especially when the ground is soft.

Caution – glazing suckers

These are very useful at manoeuvring the glass within the frame or as a third hand on the glass but we would advise you not to use it as the primary means of carrying the glass in case it slips.

And finally a note about the weather.

At this stage your greenhouse is not anchored down and is therefore vulnerable to damage by high winds.

An unglazed or partially glazed greenhouse is far more vulnerable than a fully finished model. If you are leaving a partially finished greenhouse overnight do take steps to anchor it temporarily.

1 By now you are familiar with the method of fitting the beads so we won't repeat that instruction here (refer to the window page 17 & 18 if you need a refresher).

Reminder:

Ensure that the bottom edge of the glass is sitting down fully on the horizontal profile, whether that is on the base, or eave.

Ensure that the sides of the glass are parallel to the glazing bars. Centralise the glass within the glazing bars.

Sometimes the beads can appear stiff to fit, this is usually caused by colder conditions when installing. This can be resolved by applying warm soapy water to them before they are fitted or store in a warm environment.

2 Start by glazing the 4 corners of the sides and roof as this will show you whether you have the greenhouse set perfectly square.

Once you are sure it is square, tighten the remaining loose nuts on the side and roof stays.

Slide the top edge of the glass up under the recess in the eave immediately below the gutter – as shown by the arrow. Let the glass gently down so that the bottom edge is resting on the base and the sides are pushed in tight against the glazing bars. As long as it doesn't get knocked, it can't fall out.

A glass sucker would be useful during this process if you have one as it would allow you to control the operation more accurately. If not place a hand on each face of the glass by putting your hand through the next bay.

CHECK THE REMINDERS IN SECTION 1

Start clipping the beads in from the bottom on the roof and the top on the sides. The roof beads will require cutting, but the side beads will not. Clip the glazing beads into position using the method described in the window section. Make sure that the beads are fully snapped in otherwise they are not retaining the glass. You can tell if part of the bead is not fully clipped in because there will be a slight bulge in the bead. The front & rear pane C can be glazed in exactly the same way as the side but note that there are three differences with the beads.

3 Glazing the roof. We would urge the person on the inside to wear safety goggles if not both of you.

Note that the roof glass is joined with an "H" section plastic strip and sealed at this point with silicone. There are 3 different types of "H" section supplied. For the roof, use the type shown here 

Note also that it must be fitted this way up with the longer sides facing down.

Lay pane G in position, take a couple of "W" glazing clips and secure the bottom of the glass with them temporarily. Don't lose them you will need them later.

Squeeze sufficient silicone into both sides of the "H" so that you will ensure a good seal but not too much otherwise it will look messy.

Push the "H" over the top edge of the glass so that it is positioned centrally.

Place pane B in position. To do this push it up into the recess in the ridge, lift pane G up slightly at the top and push the top pane, B back down into the "H" so that you have a good seal.

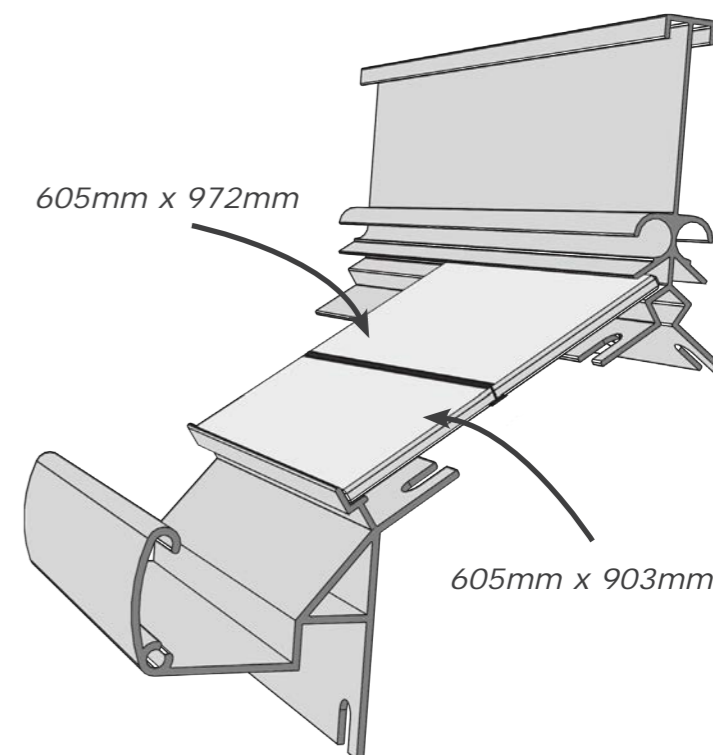

Squeeze a little more silicone from the "H" onto the glazing bars.

Use the 1924mm glazing beads for the roof. Remove the temporary "W" clips.

Start the bead level with the end of the glazing bar, not the end of the glass. Start clipping the beads in at the bottom and work your way up, a few inches at a time on alternate sides. If you were to clip a whole bead in and then move to the other bead the glass will have been pushed over and the second bead will not clip in.

4 Use the standard 1489mm bead next to the corner but this will need to be cut short to 1470mm because of the nuts and bolts at the eave.

- A. Use the longer 2347mm bead on the other side. Start this off at the bottom but stop clipping it into place 150mm from the top of the glass at this stage.
- B. Well done, hopefully that wasn't too bad. Have a break & Imagine how many panes you would have fitted already if you were using the standard 24" x 18" glass!

5 Glaze the corner panes S.

Start at the rear end in the right hand corner. Fit the "H" section glass joining strip on top of the pane C already in position in the frame. Make sure that it is this way up. The longer downward leg is to be on the outside.

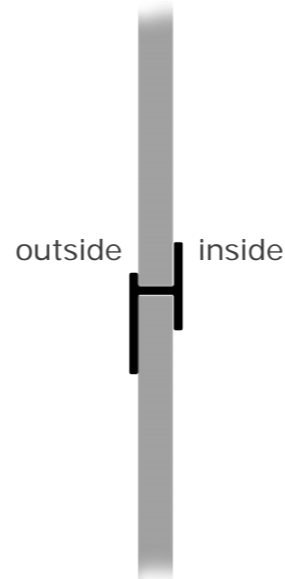

Place pane S on top of the "H" section. You will note that the corner of this pane has a cutaway to help it pass behind the nut and bolt at the eave.

Use two of the 'W' clips to temporarily hold the 'S' pane while you make progress elsewhere.

6 Glaze the next end bay using pane F and corner pane S.

Fit the H-section glass joining strip on top of the pane C already in position in the frame.

Place pane F on top of the H-section and clip in the glazing beads a bit further up to retain the glass.

Fit a further H-section on pane F. Fit pane S as described in section 5 again using 2 "W" clips on the corner roof profile. Cut the beads as previously described.

7 Cut a bead measuring 1924mm down to 1824mm and feed it behind the glazing bar.



There is an alternative method if you find this difficult. The beads could be cut to shorter lengths to fit one per bay. This is only a cosmetic issue really, either method will retain the glass perfectly well.

Continue to glaze the rest of the rear in the same way.

When glazing above the door you will need to use the black 'H' section strips R92/14, these are needed to space the glass correctly.

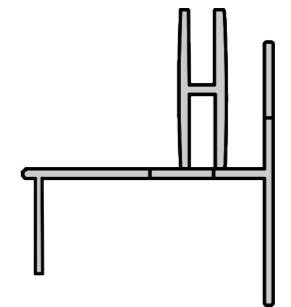
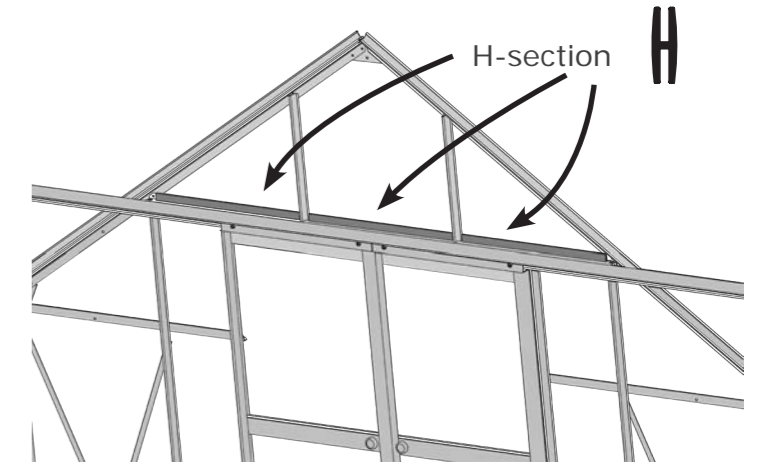

8 Cut the last two long beads down to 1900mm and use these for the door posts.

Proceed in exactly the same way as you did for the rear but note that the top point of the corner panes pass through a cut-out in the door track mount just behind the door track.

That's the hardest part of the glazing completed, well done.

Glaze the shaped panes

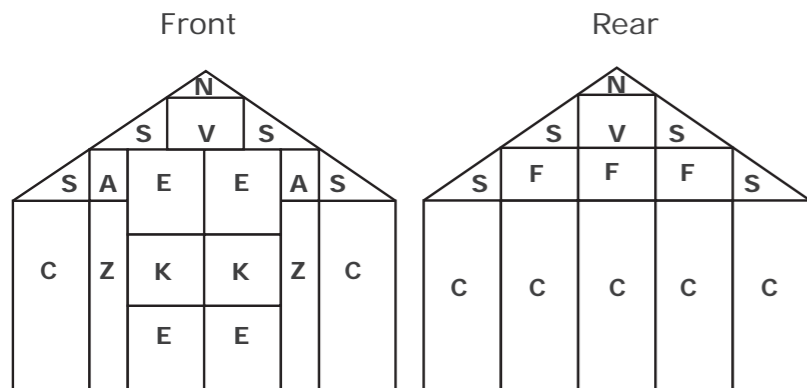

The glazing plan below is for a 10x14 – other sizes vary only in the number of windows.

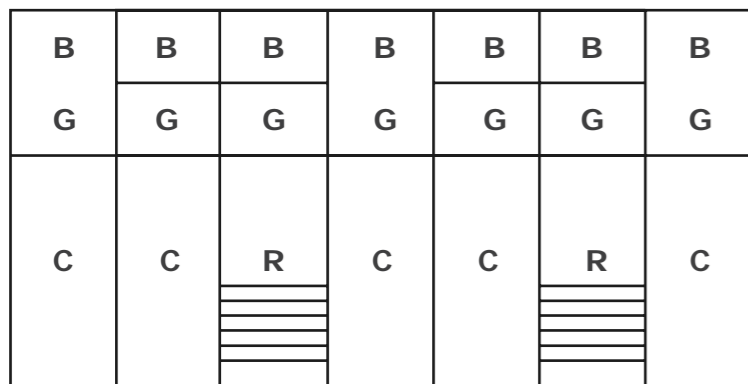

Still on this pane fully clip the long glazing bead all the way to the top of the glazing bar.

Finish glazing



single roof vent



triple roof vent

You will need...

Vent and Louvre fixings pack

LP1/
LP2  R92/55 Roof vent stops

R90/52 M5x12 pozi pan

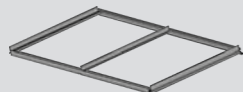
 Single or double vents

8 Two people are needed to finish glazing the roof, one on the outside and the other supporting the glass from the inside. We would urge the person on the inside to wear safety goggles if not both of you.

A. First push the glass into this recess in the ridge.

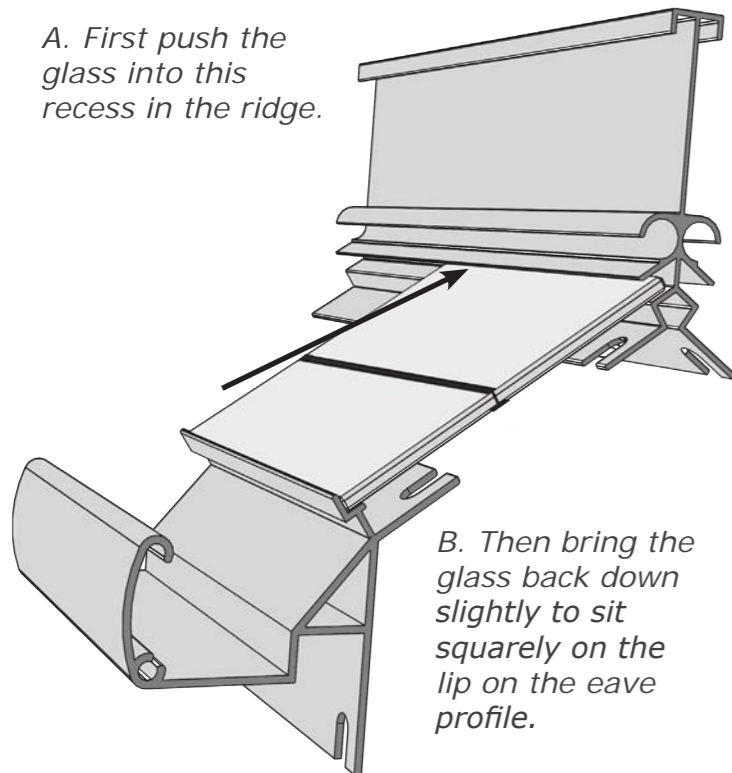

B. Then bring the glass back down slightly to sit squarely on the lip on the eave profile.

9 Clip the beads into place just as before – a little one side then the other for the length of the beads.

Start the bead level with the end of the glazing bar, not the end of the glass.

You may wish to apply a bead of silicone to ensure a good seal between the ridge and the top of the glass, although we do not believe this to be necessary in normal conditions.

10 If the glass is slightly more to one side than the other you may find that one of the beads is tightly in position while the other is loose. Don't worry, if it has been fully clipped in then it won't fall out but it may slip down the glass towards the gutter. To prevent this, apply a little silicone to the upper part of the inside of the glazing bead at the exposed end at the eave.

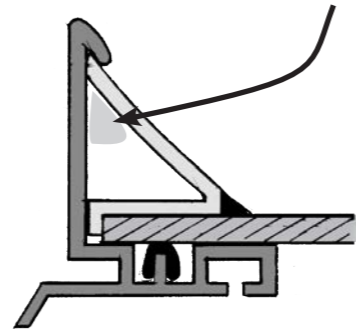

Try & avoid sealing the whole of the bead as you would block any water from draining that may find its way behind the bead.

11 When you fit pane G 605x903mm below the roof vent you may well need to make a final adjustment to the vent crossbar which you fitted earlier in approximately the right position. Move it up or down in order that it is close to the top of pane G.

You will recall that when you glazed the roof vents you cut the glazing bead and saved the off-cut. Use this now on pane G.

Once the beads are clipped in apply a bead of silicone to seal between the top of the glass & the underside of the vent crossbar.

12 With the glazing now complete the roof vents can be slid into position. Note that the vent has to be slid into the ridge from the end of the greenhouse (as in both drawings top right)
If your greenhouse has more than one vent

assembly per side of the roof you will be required to slide the roof vent stops between vents. See main drawings which indicate this.

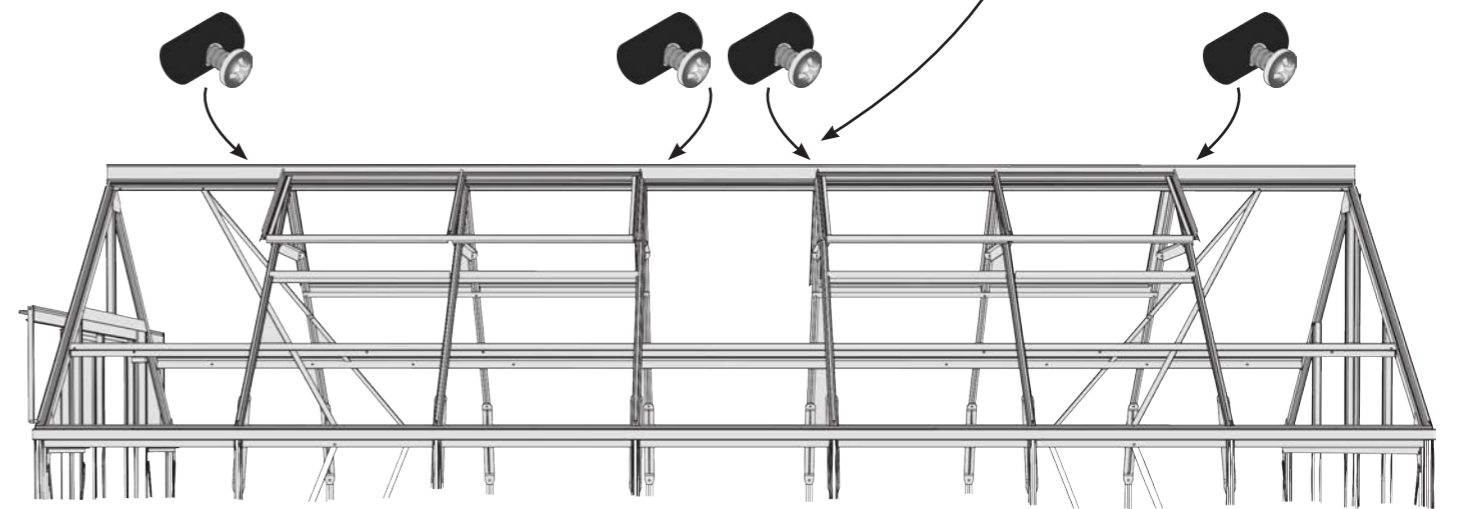
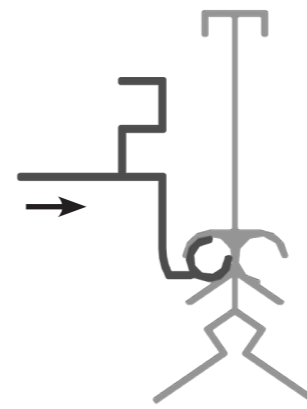
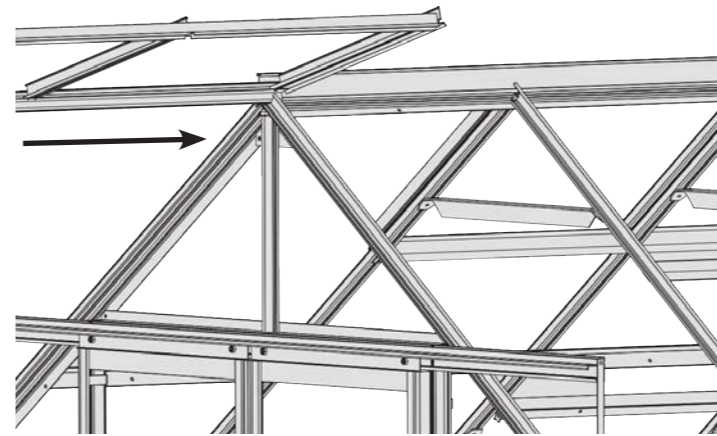

13 Prior to fitting the auto vent openers to the roof vents, please make sure to fit the vent stops R92/55, these will ensure that the vent cannot move once in the Ridge.

The method for fitting the roof stops varies between different sized greenhouses. You can either reach from each gable end. Or, if you simply can't reach or for larger greenhouses then propping open the window, and reaching out from the inside. In both cases screw the machine screw into the vent stop, slide into the ridge, just as you did with the vent and with them pushed hard against the vent hinge tighten the screw.

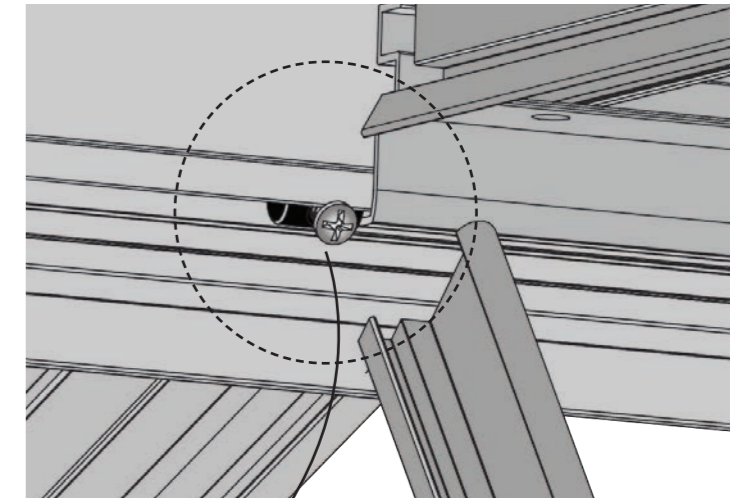

ATTENTION!

The roof vents are heavy! You and your assistant will need to stand on stepladders, holding the vent above your heads. Consider the hazards and take adequate precautions: Ensure that your stepladders are firm, level and not slippery. Wear eye protection. Eliminate any trip hazards. Practice lifting the vent between you before you consider doing this for real on a stepladder. It can be helpful to apply some WD40 to the circular part of the hinge before inserting in to the ridge

Check & tick before moving on...

- That the roof vents do not foul on the vent crossbars –if they do catch then after centralising the vent move the vent crossbar up a few mm. Ensure that the vent cross-member is sealed with silicone.
- That you have fitted the roof vent stops.

Final jobs
1st of 4 pages



Fit door track



Fit sliding doors

You will need...

EP Door track R18/3

EP Door track support R31/4

From the door fixings pack

EP Door stop bracket R94/28
M6x8 socket button head S/S R90/47
M4X8 Pozi pan S/S R90/48
Door stop buffer R90/49

1 The door track R18/3 can now be fitted to the door track mount. Slide bolts into the channel in the back of the door track and offer it up to the holes in the track mount, tighten the nuts by hand then offer the Door Track support R31/4 to the track to get the correct position. Now the nuts can be tightened.

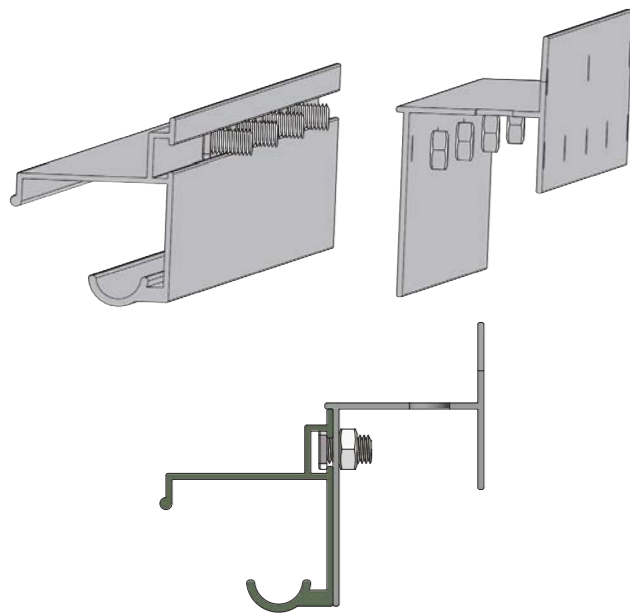

IF YOU HAVE CHOSEN TO FIT DOWNPIPES TO THE DOOR END OF YOUR GREENHOUSE YOU WILL NEED TO REMOVE ONE OF THE DOWNPIPE BRACKETS TO ALLOW THE DOORS TO SLIDE ONTO THE TRACK. Having done this Slide the doors onto the track making sure that the door with the odd meeting Stile is fitted as the left hand door.

You can now refit the Downpipe bracket, and clip in the loose glazing bead.

2 Fit the door track supports 2 x R31/4 (16mm angle).

On page 21 you fitted the long bolt & 3 nuts into the roof corners for the door support stays. Fit the support now & bolt to the channel on the back of the door track.

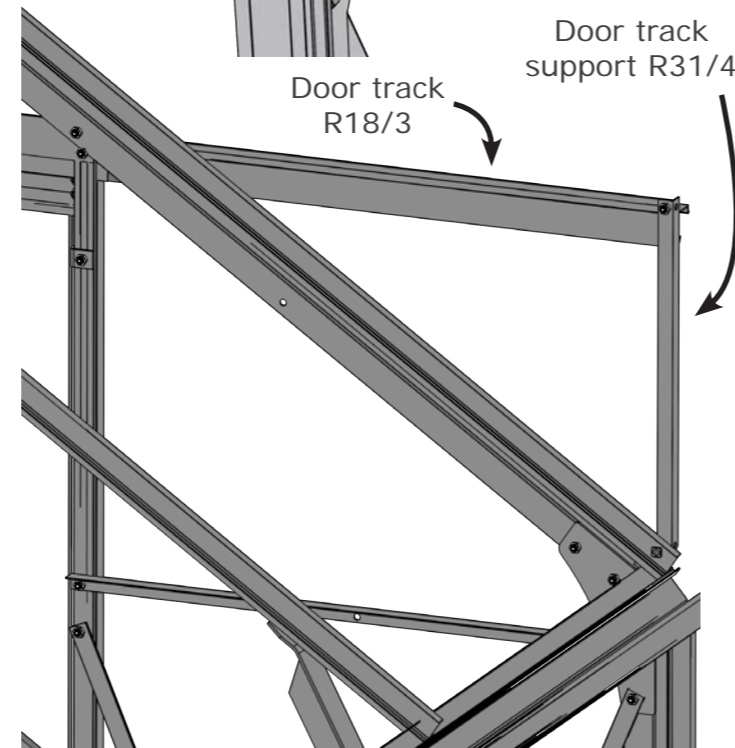
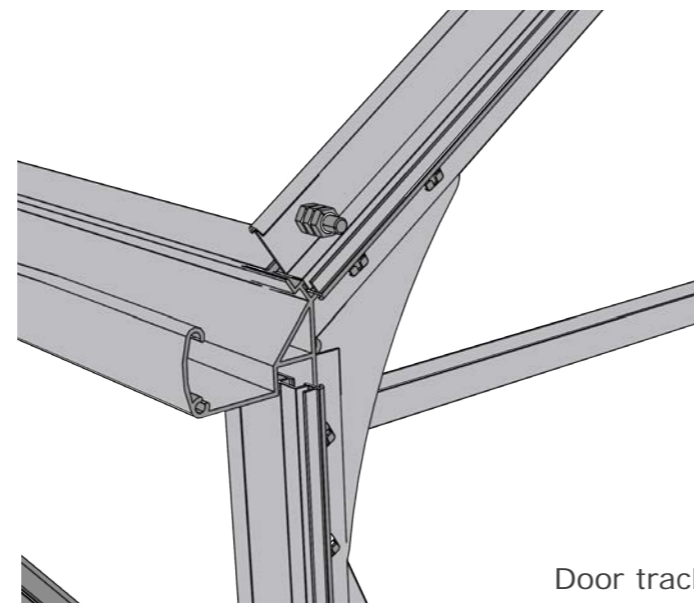

3 Fit the door stop brackets R94/28 to the door posts.

Much earlier on page 11 point 4 you slid 2xM6 flat nuts in to each door post. Use these to connect the parts as shown below, but leaving the R90/47 finger tight.

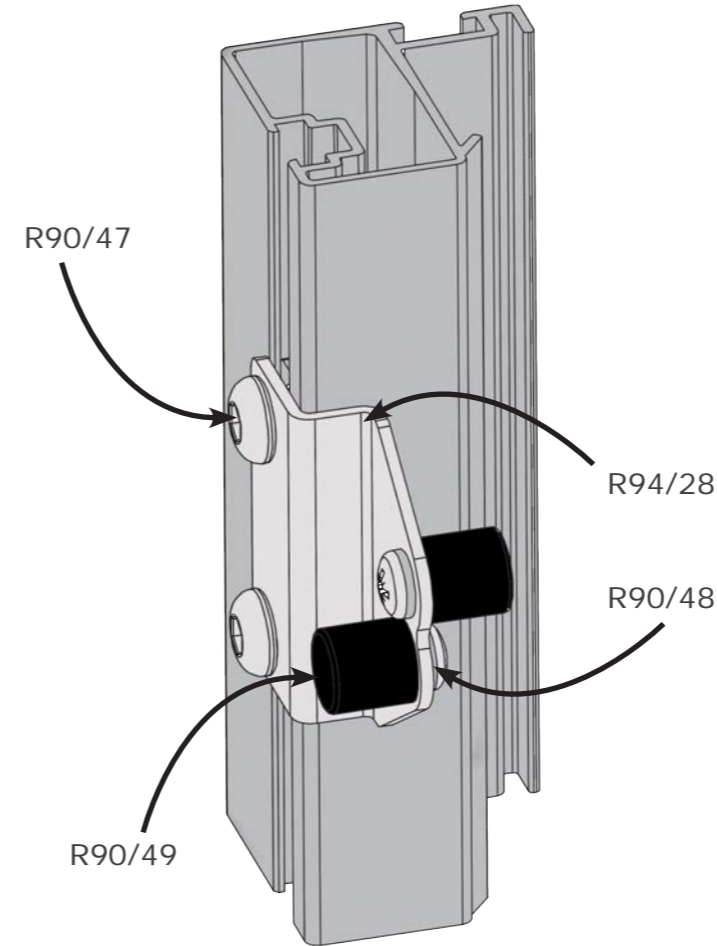

4 Position the door stop bracket level with the lower door transom and tighten the R90/47 repeat for the other door post.

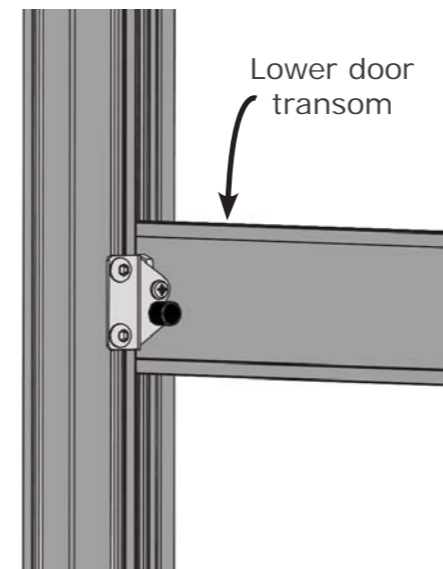

Final jobs
2nd of 4 pages



Autovent



Roof vent storm lock

4 Fit the Autovents

Two autovents are required for a double vent, a single vent requires one.

Refer to the instructions inside the autovent box and fit the cylinder to the assembly. Please note that before screwing the cylinder into position within the autovent frame please lubricate the thread with oil. Failure to do this is likely to make it difficult to adjust the temperature and can lead to damage.

Fit the autovents by using the clamps to fit to both the vent cill, and vent crossbar. Make sure when connecting to the vent crossbar that you use the centre holes in the clamp, and secure through the slot.

See drawing's below.

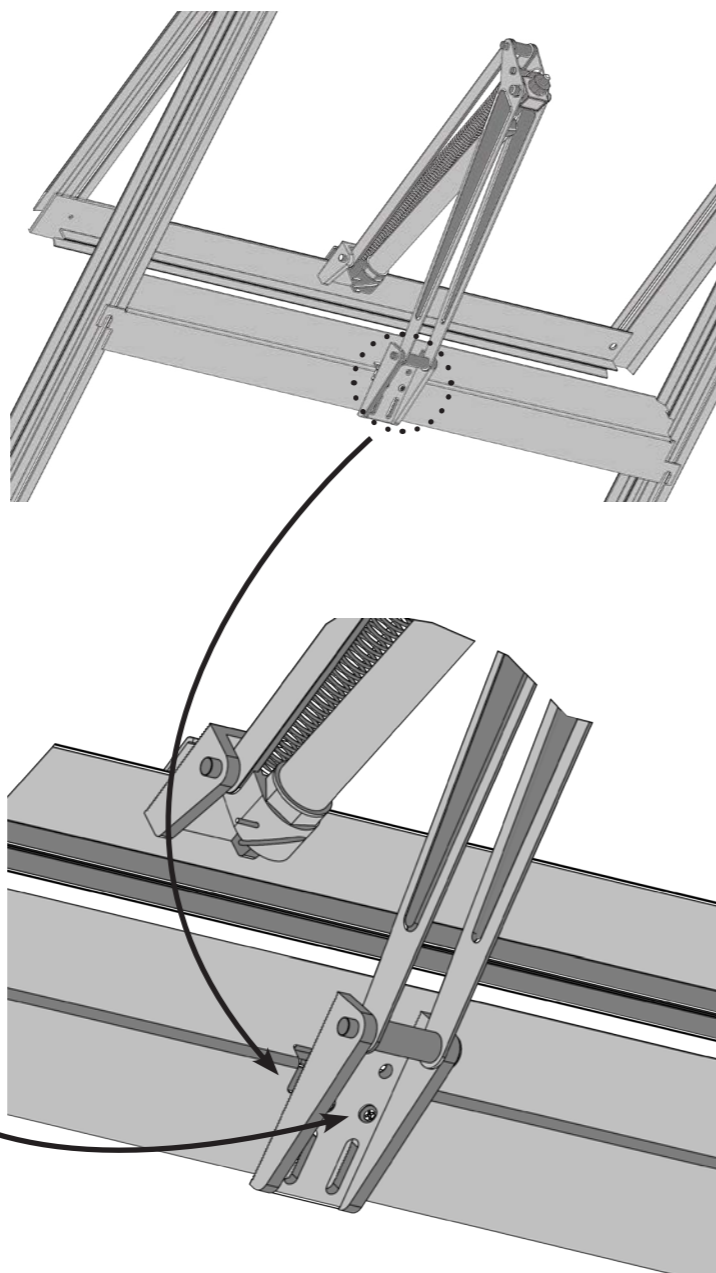

5 Fit the window locks

The autovents supplied with your greenhouse are a good quality to help stop the roof vents being lifted in strong winds. There is still a risk that a strong gust of wind will lift the vents and cause damage to your greenhouse. To prevent this we have supplied window locks. Before locking the windows make sure you have disconnected the autovent, you do this by simply removing the pin and releasing the cylinder from its housing, (refer to autovent instructions).

Single Vents

Fit the lock to the glazing bar immediately to the left of the vent.

Double Vents

Fit the lock to the glazing bar in the centre of the vent.

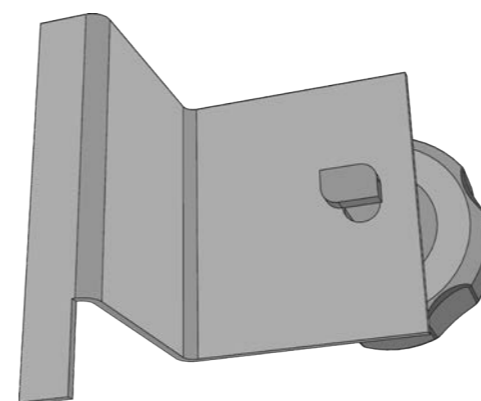

We have supplied a crop-head style bolt. This allows the bolt head to be slid diagonally into the glazing bar but will also allow it to fall out if it is left loose so tighten the knob whether you are leaving the window lock in either the open or locked position.

IMPORTANT:
WHEN LOCKING THE VENT YOU MUST FIRST OF ALL DISCONNECT THE AUTO VENT BY REMOVING THE CYLINDER RETAINING PIN AND REMOVE THE CYLINDER FROM ITS HOUSING.

The window lock in the unlocked position. The autovents must be connected when the lock is in this position. Note that it is perfectly acceptable for the lock to be removed and kept somewhere safe when not required.

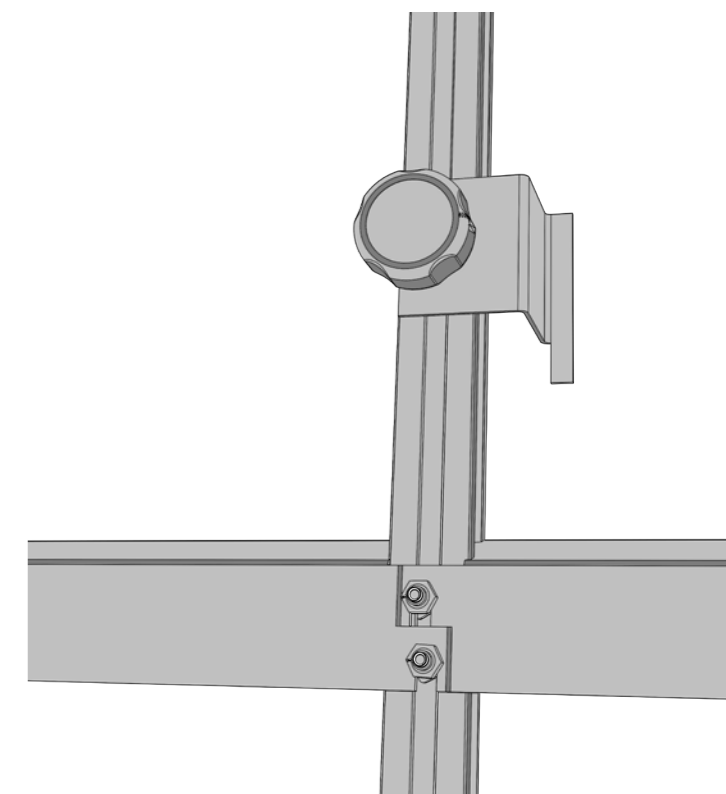

The window lock in the locked position. The vents can no longer open, The autovents must be disconnected when the lock is in this position. Otherwise they will suffer damage and need replacing.

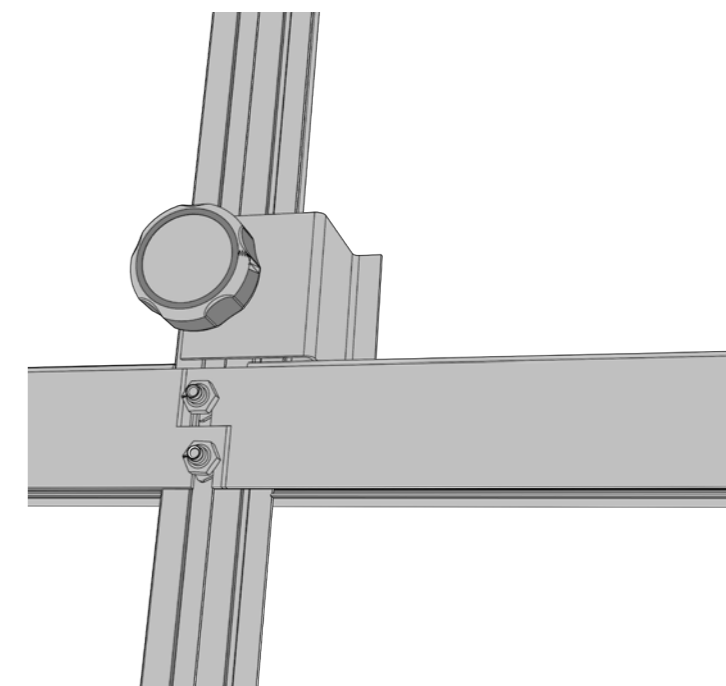

Final jobs
3rd of 4 pages



Ground anchors on a soil site

6 Fix the greenhouse down.

Refer to the pages 2 & 3 at the beginning of this manual "Before You Start Ground Anchors". Either concrete the "J" bolts into position or drill and secure the concrete anchor bolts to your concrete pad.

7 Fitting the louvre glass

Slide the louvre panes in to the carriers from the top, this will be made easier if you have the louvre in the open position.

8 Fitting the louvre glass seals

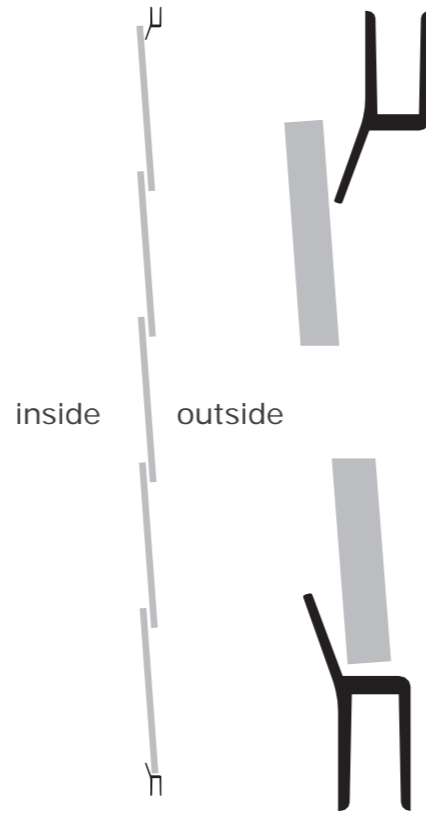

Finally, when the glass has been installed above and below the louvre you'll be able to attach the louvre glass seal strips (R92/46). The strips are fitted to both 848 & 192 panes as indicated by arrows in the diagram below with the angled edge facing inwards.

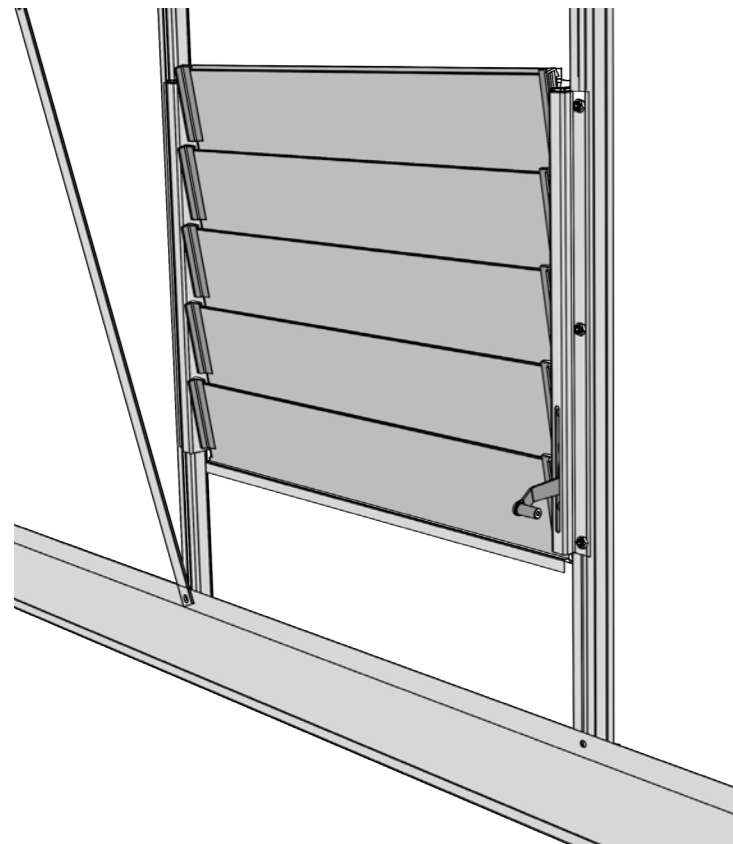

8 Fit the downpipes

Push the end cap into place and seal it inside the gutter with silicone. Do the same for the outlet and screw this into the gutter using a little oil if the screw is tight. Apply some silicone to the inside of the elbow joints.

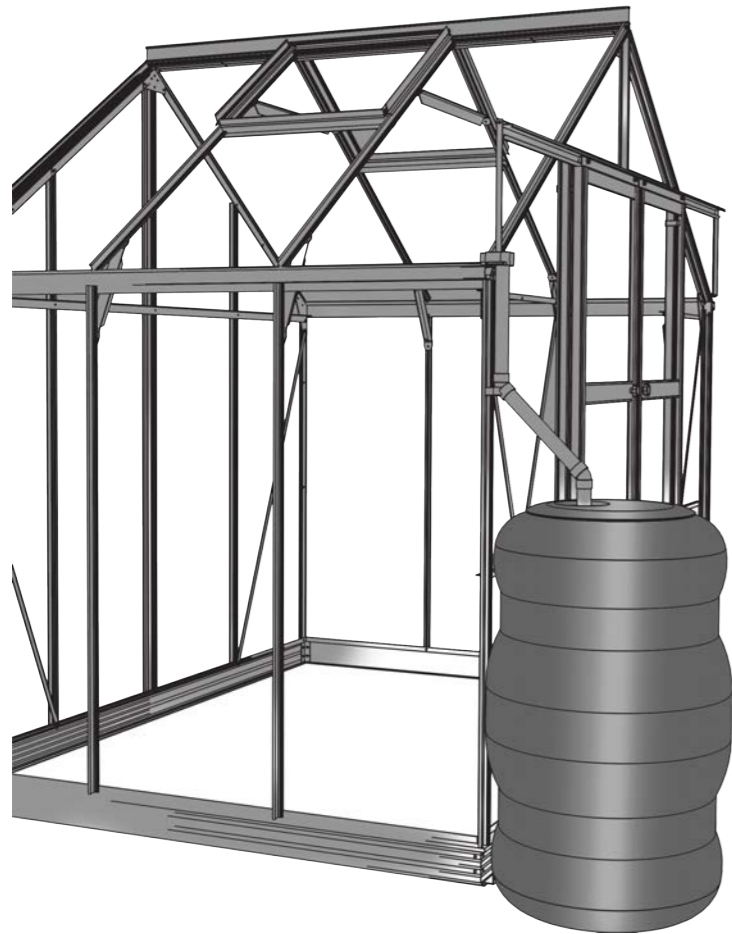
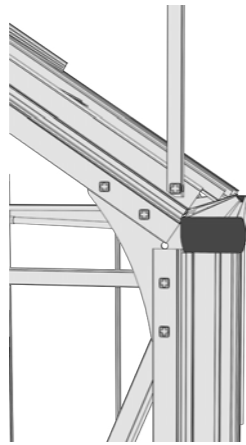

The location, shape and capacity of water butts will vary from one customer to the next so we have supplied the pipe in 1m lengths for you to cut as best suits your requirements. Should you need more pipe or fittings these will be readily available from builders merchants and DIY stores.

We have used standard 32mm waste pipe made by Osma.

9 Fitting the optional "two into one" pipes

You may have ordered the optional "two into one" downpipe kit (to join the pipes across the rear so that you only require one water butt).

The method is the same as for fitting the individual pipes but please note the following:

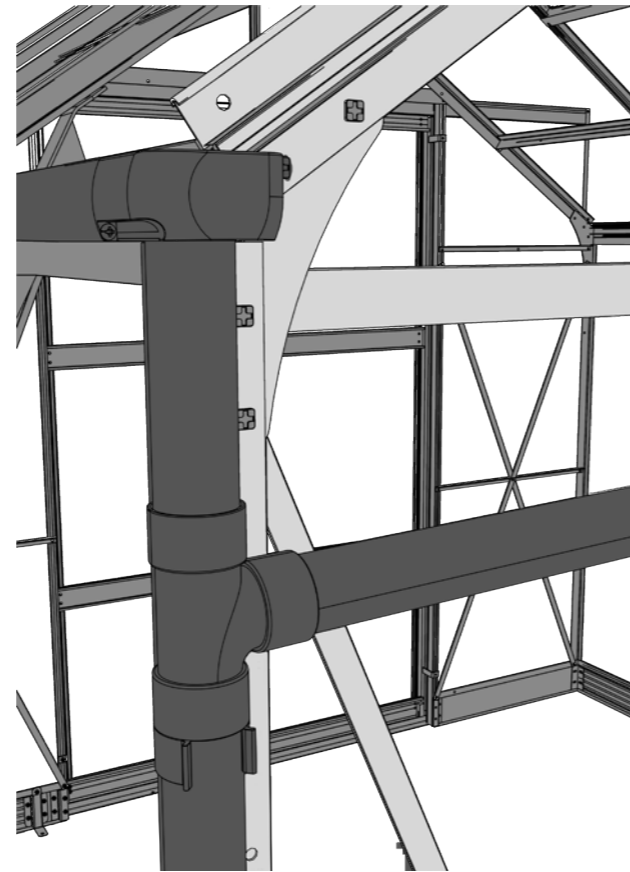

The pipe is supplied in two pieces and is joined with a straight coupler;

Where the pipe crosses the centre glazing bar, drill a 4.5mm hole through the bar attach the pipe to the centre glazing bar using the cable tie.

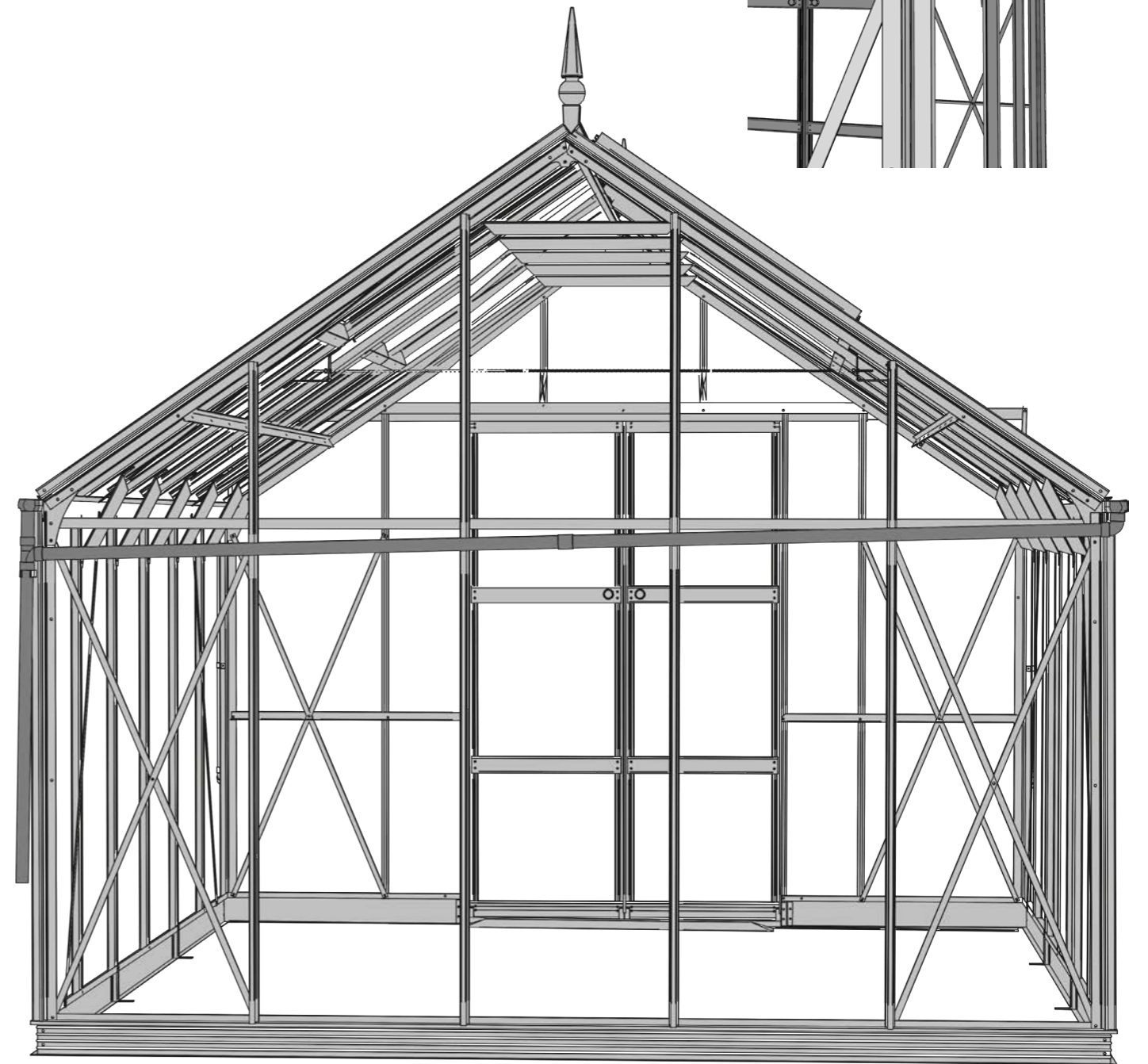
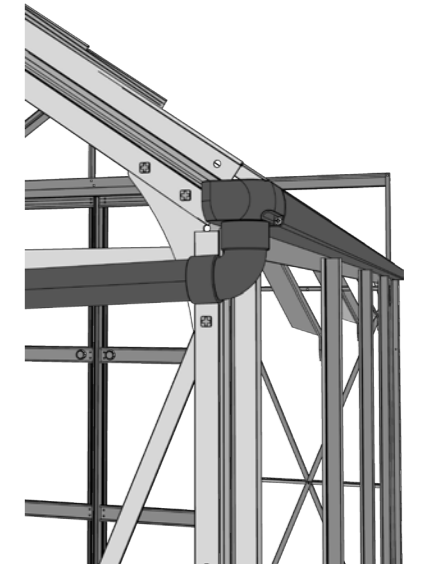

Finishing touches



Roof blinds

Blinds

For fitting blinds please see the separate blind instructions. Also see video 28.

Finial

The finial is the last item to be put on your greenhouse, please see the separate finial instructions.