

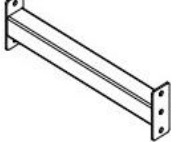

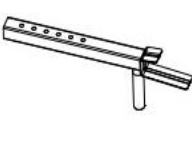

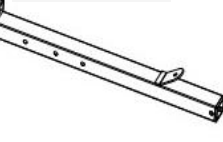





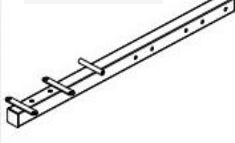
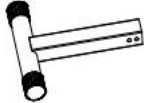
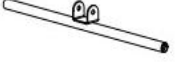

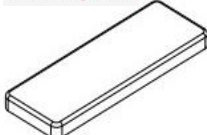

A. Connecting pipe 1件	B. Adjusting the dumbbell rack 2件	C. main pillar 2件	D. bottom tube 2件
			
E. Main beam 1件	F. forward 1件	G. shaft 1件	H. Back cushion tube 2件
			
I. Adjust the support 1件	J. Front pillar adjustment card 1件	K. Back pad adjustment card	L. seat cushion 1件
			
M. back pad 1件	N. oblique foot cover 4件	O. round foot cover 2件	P. Reducer sleeve 2件
			
Q. put on gloves 2件	R. plug 2件	S. plug 4件	
			

部 件 表-2

1. Bolt (M8*20) + Flat Washer M8



2. Bolt (M8*35) + Flat Washer (M8)



3. Bolt (M10*20) + Flat Washer (M10)



4. Bolt (M10*50) + Flat Washer (M10)

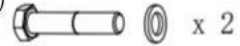

5. Bolt (M10*65) + Flat Washer (M10) + Nut (M10)



6. Bolt (M10*135) + Flat Washer (M10) + Nut (M10) 2件



7. Latch (M10*65) 2件





8. Lock knob (M16) 2件

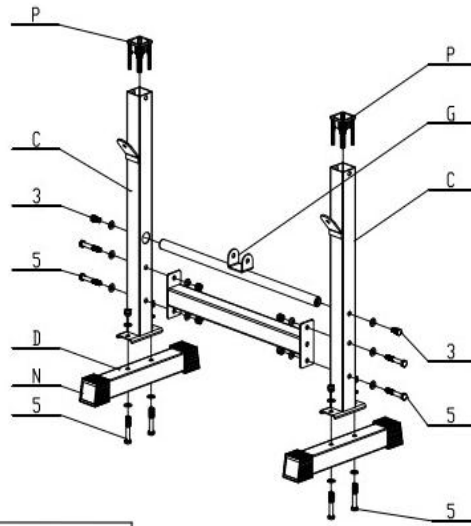

Assembly steps

(Step 1)

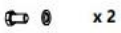

5.  x 8 M10*65 Bolt Flat Washer Nut	3.  x 2 M10*20 Bolt Flat Washer
--	--

(Step 2)

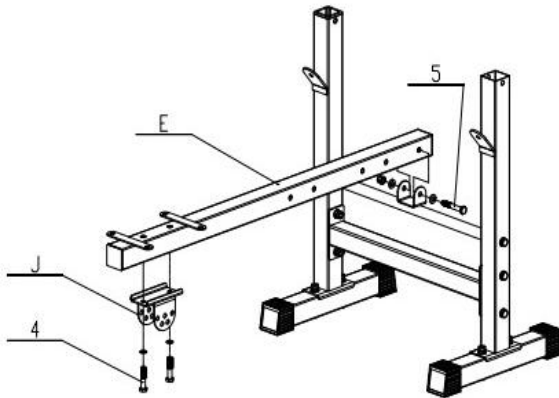

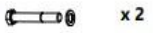
5.  x 1 M10*65 Bolt Flat Washer Nut	4.  x 2 M10*50 Bolt Flat Washer
--	--

Assembly steps

(Step 3)

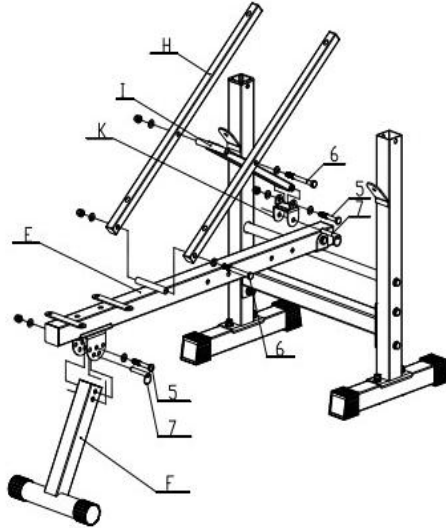

5. x 2 M10*65 Bolt Flat Washer Nut	6. x 2 M10*135 Bolt Flat Washer Nut	7. x 2 M10*65 latch
--	---	-------------------------

(Step 4)

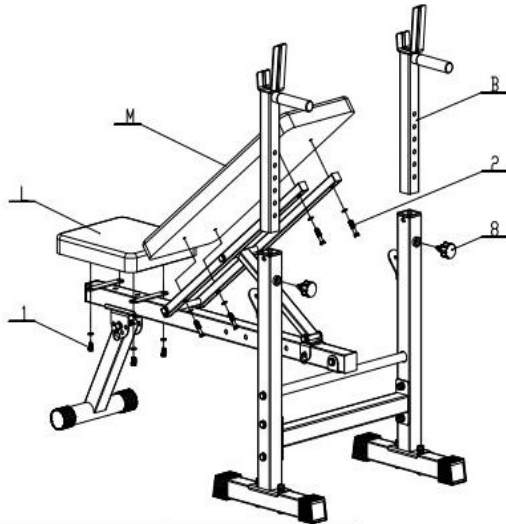

1. x 4 M10*20 Bolt Flat Washer	2. x 4 M10*35 Bolt Flat Washer	8. x 2 M16 knob
------------------------------------	------------------------------------	---------------------