

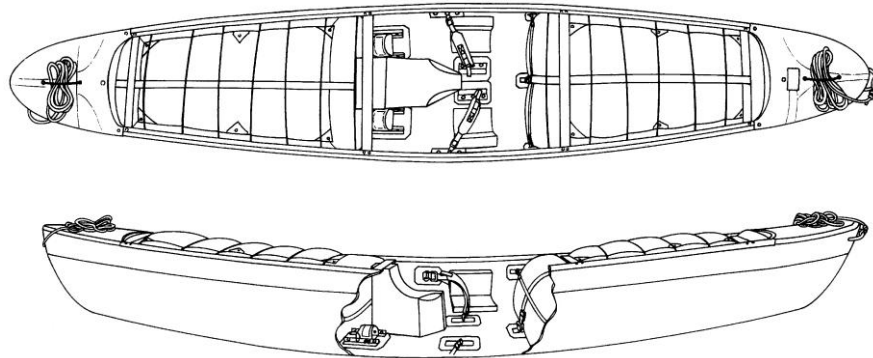

## Air Bag Tie-Down Kit

These kits are used to secure flotation bags into your canoe. This kit contains everything you need to secure two large end bags in a solo boat, or two small bow and stern bags and one large center bag for a tandem boat. Installation is quite simple and should only take you about 30 minutes.



**Note:** Read over these instructions thoroughly. If you do not feel comfortable with any of the steps please feel free to contact us or your nearest dealer.

### CONTENTS INCLUDE

- 2 – 1" X 7" Center Straps
- 2 – Center Strap Anchors (1" D-Ring & Buckle Anchor)
- 2 – 1" x 3.5' End Straps
- 8 – End Strap 1" D-Rings
- 28 – Lacing D-Rings
- 28 – Stainless Steel Screws and Washers
- 50' of Parachute Cord

### FOR INSTALLATION YOU WILL NEED

- Pencil or felt marker
- Mineral spirits (Toluene or MEK)
- Vinyl adhesive (Vinyl-Tec 2000)
- Piece 80 to 100 grit sandpaper (for Kevlar and fiberglass boats)
- Heat gun or hair dryer (optional)
- Drill and 5/64" bit
- Clean-up rag
- Rubber gloves

## **INSTRUCTIONS**

**Note:** Your air bags should be installed so when fully inflated all the lines and straps fit snugly against the contours of the inflated bags. This not only secures them in place but reduces the likelihood of anything snagging in the lines. See the diagram on page 1.

If your boat has pre-installed lacing anchors you can skip steps 1 and 2.

- 1) Determine the location of the air bag you wish to install by placing it into the boat partially inflated. Flatten down the air bag by pushing it level with the gunnels. For large center bags, place a mark on the gunwale at each end of the airbag, for solo and end bags put a mark where the bag ends. Making sure the solo bags are pulled well into the bow and stern to avoid pockets where water can collect. From those marks measure 4 to 5 inches toward the center of the bag. This will be the location of the first Lacing D-ring on the gunwale.
- 2) Remove the air bag and measure the distance between the two marks and determine how many D-rings you need for each side. They should be approximately 4 inches apart. Place a mark at each location. Now place the plastic tab on the Lacing D-ring on the underside of the gunwale and drill a 5/64" pilot hole into the tab and the gunwale, secure them using the screws and washers provided. Repeat using the same layout for the gunwale opposite the one you just finished.
- 3) To install the Center Strap Anchor, measure 2 inches toward the center of the bag from where the bag ends. Do the same for the other end if it is a center bag.
- 4) To install the D-rings for the End Straps, measure approximately 8 inches down from the underside of the gunwale. Again making sure they are placed about 2 inches in from the end of the bag. (See diagram)

Gluing in the D-rings and anchors should be performed in a well ventilated area.

## **CAUTION**

The water conditions in which this product is used are potentially hazardous and require experience and skill. Upon purchasing North Water Equipment, the purchaser / user is responsible for ensuring that they have the adequate training and experience necessary to operate in such conditions. The purchaser / user assumes all risks of injury or damage to themselves as well as loss or damage to any property. In purchasing / using these products (s)he agrees to hold harmless North Water Holdings Ltd., their officers, employees, agents, and representatives from any liability for injury or damage of any kind that may be suffered by the purchaser or others through the use of these products whether caused through negligence or otherwise.