

# How to use Shape B + Examples

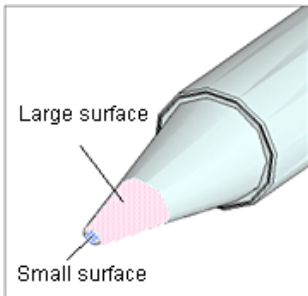

Shape B is a general rounded shape that can be used from any direction and is easy to hold at any position. It is possible to solder any surface from small to large, suitable for a wide range of projects, and is a good tool for both beginners and experts.

## Drag Soldering

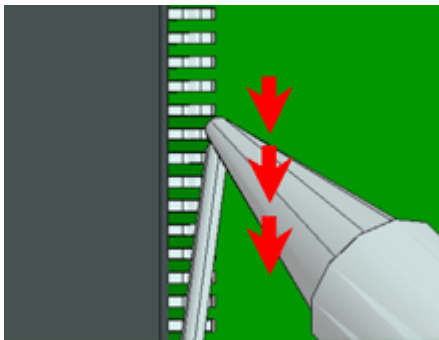

Put the tip end to the leads and drag the tip slowly while feeding solder.

**NOTE:** Apply flux to the leads and land pads before soldering. It helps to prevent problems such as solder bridges.

## Soldering Chip Parts

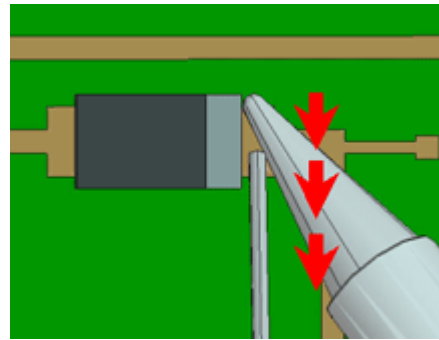

Put the tip to the board and drag the tip slowly while feeding solder.

**NOTE:** Some IC are specified by the manufacturer not to be touched on the electrode by tip end.

## Point Soldering

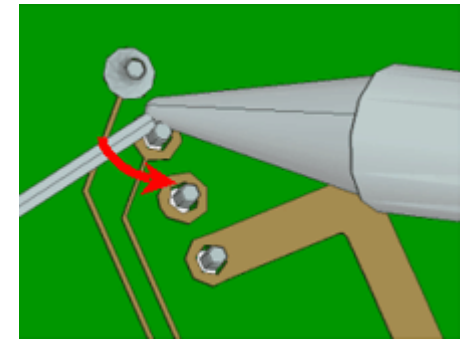

Put the tip end to the board and the through-hole at one time to heat them.

Feed solder to form smooth fillet on the land pad.