

SD212-HF2P2LDF(D00B-ABK) 2 dipole, 4.5 dBd, low PIM, HD, ABK, 138-174 MHz

- 2-bay dipole antenna that covers the 138-174 MHz band
- 4.5 dBd gain with bi-directional pattern
- Top mount, heavy duty, low PIM, black anodized
- 300W power handling

Recommend SMK-425-A3-T3 or SMK-425-A7-T3 for Offset Side Mount.
Available from Sinclair separately.

The SD212-HL series is a heavy duty, low intermodulation, extremely rugged 2-bay exposed dipole antenna designed for applications where moderate gain is required. These premium-quality antennas are well suited to public safety applications.

The design of these antennas provides for coverage between 118 to 225 MHz in 3 sub bands, 118-138 MHz for civil aviation applications, 138-174 MHz for private mobile networks, public safety and public security and 220-225 MHz for transportation networks.

The SD212-HL is also low PIM utilizing industry-leading designs that offer high gain, excellent bandwidth and high reliability. The standard connector offered is 7/16" DIN female.

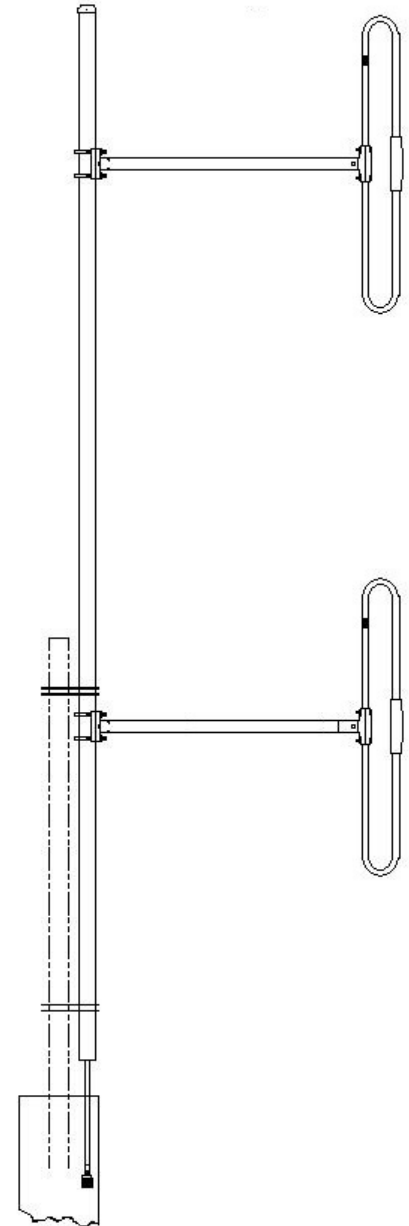

Antenna may not appear exactly as picture.

www.sinctech.com

Region	United States	Europe, Middle East and Africa	Caribbean and Latin America	Canada and rest of the world
Telephone	USA: 1 800 263 3275	International: +44 (0) 1487 84 28 19	International: +1 905 726 7676	Canada: 1 800 263 3275 International: +1 905 727 0165
E-mail	salesusa@sinctech.com	salesuk@sinctech.com	salesla@sinctech.com	salescan@sinctech.com

Electrical Specifications

Frequency Range	MHz	138 to 174
Bandwidth	MHz	36
Connector		7/16 DIN-Female
Gain (nominal)	dBd (dBi)	4.5 (6.6)
Input VSWR (max)		1.5:1
Polarization		vertical
Impedance	Ω	50
Pattern		Bi-directional
Vertical beamwidth (typ)	degrees	36
Average Power Input (max)	W	300
Passive intermod. (2x20W, 3rd ord.)	dBc	-150
Lightning protection		DC ground

Notes

*1 : Qty 2

Mechanical Specifications

Width	in (mm)	42.62 (1083)
Depth	in (mm)	4.75 (121)
Length/ Height	in (mm)	120 (3048)
Base pipe diameter	in (mm)	2.38 (60)
Base pipe mounting length	in (mm)	30 (762)
Radiating element material		aluminum
Base pipe material		aluminum
Finish		anodize (black)
Weight	lbs (kg)	42 (19.07)
Weight iced (1/2" ice)	lbs (kg)	84 (38.14)
Mounting Hardware (Optional)		Clamp005, Clamp015, or Clamp130 *1
Actual shipping weight	lbs (kg)	70 (31.78)
Shipping dimensions	in (mm)	132x48x6 (3353x1219x152)
Mounting configurations		top mount
Recommended For Offset Side Mount:		Not Required

Ordering Information

Clamps must be ordered separately.

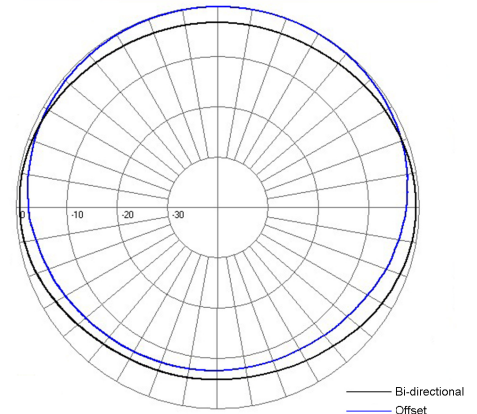

Environmental Specifications

Temperature range	°F (°C)	-40 to +140 (-40 to +60)
Wind Loading Area (Flat Plate Equivalent)	ft² (m²)	2.75 (0.26)
Wind Loading Area (1/2" ice)	ft² (m²)	4.3 (0.4)
Rated wind velocity (no ice)	mph (km/h)	185 (298)
Rated wind velocity (1/2" radial ice)	mph (km/h)	155 (250)
Lateral thrust (100 mph No Ice)	lbs (N)	101 (449.2)
Torsional moment (100 mph No Ice)	ft-lbs (Nm)	96 (129.6)
Bending moment (100 mph No Ice)	ft-lbs (Nm)	340 (459)
Tip deflection (100 mph No Ice)	degrees	0.4

Region	United States	Europe, Middle East and Africa	Caribbean and Latin America	Canada and rest of the world
Telephone	USA: 1 800 263 3275	International: +44 (0) 1487 84 28 19	International: +1 905 726 7676	Canada: 1 800 263 3275 International: +1 905 727 0165
E-mail	salesusa@sinctech.com	salesuk@sinctech.com	salesla@sinctech.com	salescan@sinctech.com