

PC3114 I.M. Suppression panel, rack mount, single stage isolator, 125 Watt load, 406-512 MHz

- High performance single stage isolator provide 35 dB of isolation
- Comes with built-in harmonic filter that provides 40 dB rejection at 2nd harmonic
- Compact design precisely tuned to customer specified frequency

Sinclair's PC series panels incorporate high performance single- or dual-stage isolators with various load terminations and Sinclair-built harmonic filters. These compact units offer optimum intermodulation control in a 19-inch rack mounted configuration. They are shipped precisely tuned to customer specified frequency, and exhibit 25 dB or 50 dB isolation when equipped with single- or dual-stage isolators respectively. Various load configurations are available depending on system power level and VSWR protection required.

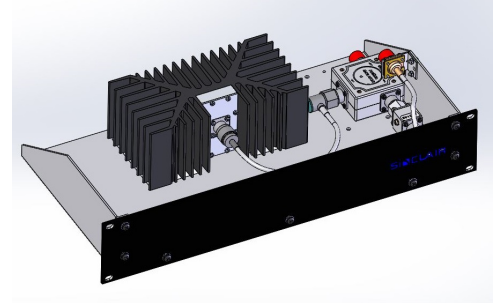

www.sinctech.com

Region	United States	Europe, Middle East and Africa	Caribbean and Latin America	Canada and rest of the world
Telephone	USA: 1 800 263 3275	International: +44 (0) 1487 84 28 19	International: +1 905 726 7676	Canada: 1 800 263 3275 International: +1 905 727 0165
E-mail	salesusa@sinctech.com	salesuk@sinctech.com	salesla@sinctech.com	salescan@sinctech.com

Electrical Specifications

Frequency Range	MHz	406 to 512
Bandwidth	MHz	12
VSWR (max)		1.25:1
Average Power Input (max)	W	125
Connectors		N-Female
Insertion Loss (max) Tx to Ant	dB	0.5
Isolation (min)	dB	25

Mechanical Specifications

Width	in (mm)	19 (483)
Depth	in (mm)	9.13 (232)
Length/ Height	in (mm)	3.5 (89)
Actual shipping weight	lbs (kg)	20 (9.08)
Shipping dimensions	in (mm)	26x19x7 (660x483x178)

Environmental Specifications

Temperature range	°F (°C)	-22 to +140 (-30 to +60)
-------------------	---------	--------------------------

www.sinctech.com

Region	United States	Europe, Middle East and Africa	Caribbean and Latin America	Canada and rest of the world
Telephone	USA: 1 800 263 3275	International: +44 (0) 1487 84 28 19	International: +1 905 726 7676	Canada: 1 800 263 3275 International: +1 905 727 0165
E-mail	salesusa@sinctech.com	salesuk@sinctech.com	salesla@sinctech.com	salescan@sinctech.com