

INSTALLATION INSTRUCTIONS
SC281-HF(*)LDF(DXX) SERIES
SC412-HF(*)LDF(DXX) SERIES
SC389-HF(*)LDF(DXX) SERIES
SC442D-HF(*)LDF(DXX) SERIES
SC49C-HWBLDF(DXX) SERIES
SC251D-HF(*)LDF(DXX) SERIES
SC351D-HF(*)LDF(DXX) SERIES

ITEM NO.	PART NUMBER	DESCRIPTION	QTY.
1	TO SUIT	ANTENNA ASSEMBLY	1
2	015768	WEATHERPROOFING KIT, WPK-1	1

NOTE:
 SMK-345 A7 PER DWG. 005859. FOR SIDE MOUNTING ONLY,
 MUST BE PURCHASED SEPARATELY.

ANTENNA INSTALLATION GUIDELINES

1. Upon receipt of your antenna, please check the material against the parts list enclosed. If shortage or damage is apparent, notify the carrier immediately.
2. Inspect the antenna feed connector(s) to determine that it mates with the end of your transmission line. Do not remove any connector or cable from the antenna as they are all part of your antenna.
3. Verify that the frequency to which the antenna has been tuned is the frequency on which your radio system is to operate. This information is on the label which also shows the model and serial number of your antenna.
4. Assemble antenna including mounting clamps as shown on your assembly sheet. Tightening torques provided must be adhered to when assembling and installing your antenna. Drain holes in the mast base and/or radiating element must face downwards and remain unobstructed at all times.
5. Always protect the cable harness and radiating element from damage when moving, lifting or resting your antenna.
6. A check of the antenna VSWR is recommended prior to installation and measurements should be recorded for future reference.
7. After checking the VSWR of the antenna, mount the antenna to the tower and ensure that it is solidly grounded. Do not rely on the feed cable for ground return. Connect the station transmission line to the antenna making sure that the centre pin of both connectors are centred. Tighten both connectors firmly by hand. **Do not use pliers.** Carefully weatherproof the cable connection (Refer to Weatherproofing Instructions 005032, supplied with Weatherproofing Kit). Failure to weatherproof the cable connection will result in improper operation of your antenna. Properly secure the feed cable and antenna transmission line to the tower in the best position to avoid damage.
8. A careful visual check is recommended to insure that:
 - a) All mechanical connections are securely made.
 - b) The antenna is mounted on the proper ledge of the tower with sufficient physical clearance.
 - c) All connections have been carefully wrapped with weatherproofing material to prevent moisture problems.

UPRIGHT POSITION, BOTTOM MOUNTED ANTENNA

TIGHTENING TORQUES FOR
NON LUBRICATED
STEEL BOLTS

BOLT SIZE	TORQUE
1/4-20	5 FT-LB
5/16-18	11 FT-LB
3/8-16	20 FT-LB
1/2-13	40 FT-LB
9/16-12	45 FT-LB
5/8-11	60 FT-LB
3/4-10	110 FT-LB

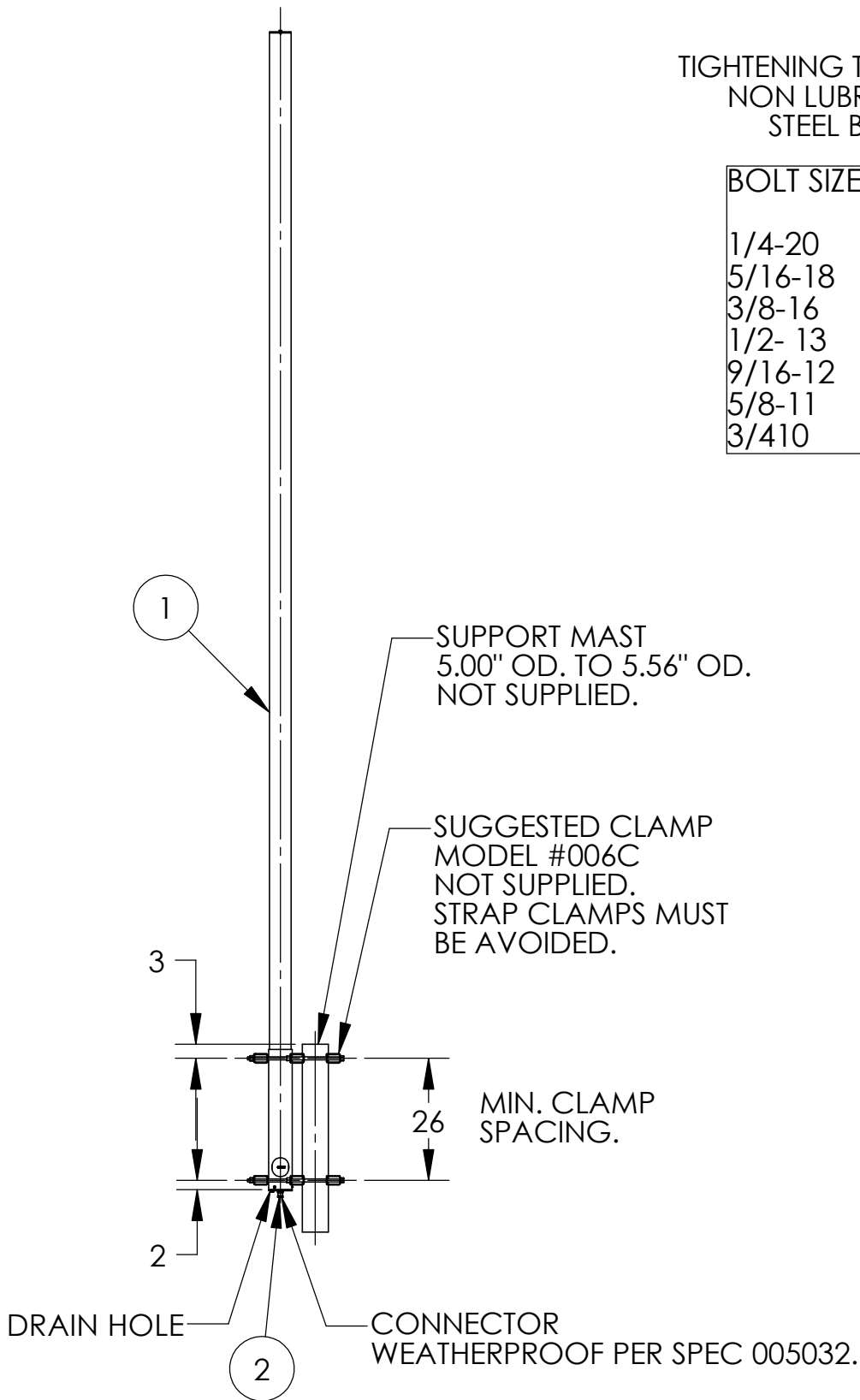

SIDE MOUNTED ANTENNA, UPRIGHT

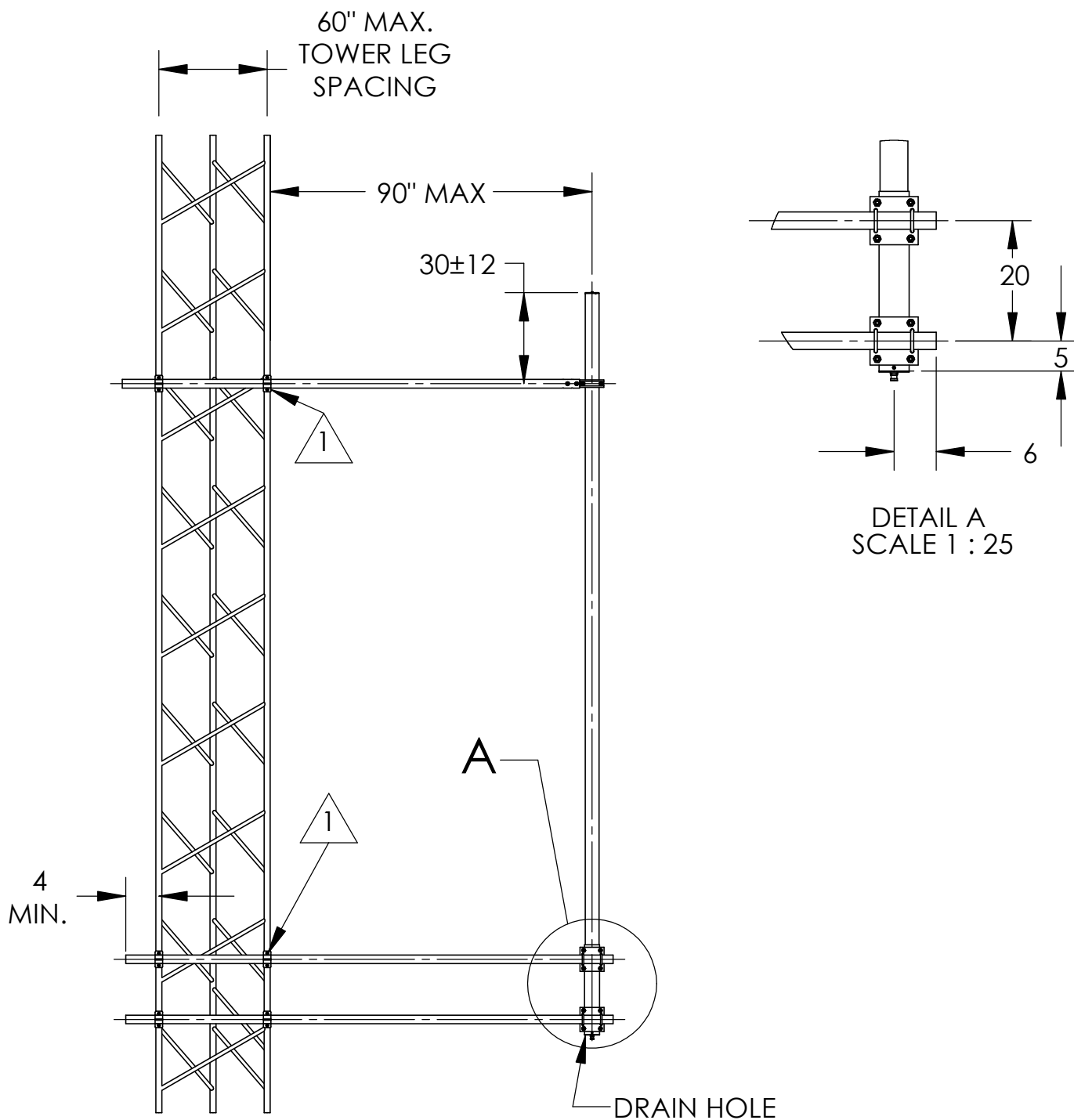

NOTE:

1. CLAMPS FOR TOWER LEGS NOT INCLUDED.
2. SUGGESTED CLAPMS FOR ROUND TOWER LEGS:
 - CLAMP #121A (1 3/4" TO 2 3/8" OD. AT 90° TO 2 7/8" OD.)
 - CLAMP #121D (1.0" TO 1 3/4" OD. AT 90° TO 2 7/8" OD.)
 - CLAMP #17HD (1.5" TO 3.0" OD. AT 90° TO 2.88" - 4.00" OD.)
3. CLAMPS FOR TOWER LEG SHAPES OTHER THAN ROUND MUST BE DETERMINED BEFORE ORDERING.