

I3113W-(X) Wide band single stage isolators, 150W input power, 350-512 MHz

- Operational in an extreme wide frequency range without retuning required
- Single stage with 60 Watts load

These wide bandwidth isolators allow for broad band and frequency flexible combining without having to readjust the isolators. When ordering, please refer to the chart below for part# and specific configurations.

Model	Frequency Range	Bandwidth
I3113W-1	350-385 MHz	35 MHz
I3113W-2	380-415 MHz	35 MHz
I3113W-3	405-440 MHz	35 MHz
I3113W-4	430-470 MHz	40 MHz
I3113W-5	459-512 MHz	53 MHz

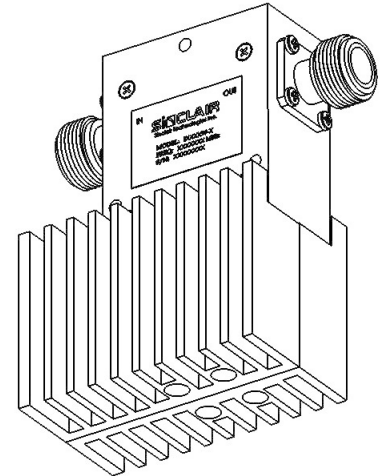

Product may not appear exactly as image

www.sinctech.com

Region	United States	Europe, Middle East, and Africa	Canada, Caribbean, and Latin America	Asia-Pacific
Telephone	1 800 263 3275	+44 (0) 1487 84 28 19	Canada: 1 800 263 3275 International: +1 905 726 7676	+1 905 727 0165
E-mail	salesusa@sinctech.com	salesuk@sinctech.com	salescan@sinctech.com	salesasia@sinctech.com

### Electrical Specifications

Frequency Range	MHz	350 to 512
Discription/ Characteristics		Single Stage
Input Connectors		N-Female
Output Connectors		N-Female
Field Tunable		No
VSWR (max)		1.2:1
Insertion loss (max)	dB	0.4
Impedance	Ω	50
Average Reverse Power (max)	W	60
Average Input Power (max)	W	150
Isolation (min)	dB	25

### Mechanical Specifications

Width	in (mm)	1.5 (38)
Depth	in (mm)	3.11 (79)
Height	in (mm)	3.46 (88)
Weight	lbs (kg)	1.2 (0.54)
Shipping dimensions	in (mm)	6x5x4 (152x127x102)

### Environmental Specifications

Temperature range	°F (°C)	-22 to +140 (-30 to +60)
-------------------	---------	--------------------------

Region	United States	Europe, Middle East, and Africa	Canada, Caribbean, and Latin America	Asia-Pacific
<b>Telephone</b>	1 800 263 3275	+44 (0) 1487 84 28 19	Canada: 1 800 263 3275 International: +1 905 726 7676	+1 905 727 0165
<b>E-mail</b>	salesusa@sinctech.com	salesuk@sinctech.com	salescan@sinctech.com	salesasia@sinctech.com