

"FP", "FR", "FQ" Series Bandpass Filters

Description

The tuning instructions described on the following pages apply to all 7, 8.5, and 10" Bandpass, Notch, and Q circuit filters.

Typical models and electrical specifications are shown for reference only. Other models and additional specifications are available from Sinclair Technologies Inc. through the website or catalog, or by contacting Sinclair Sales or Engineering Departments.

The instructions in this manual are for single cavity filters. Filter cavities may be cascaded using quarter wavelength or three-quarter wavelength interconnecting cables for greater selectivity (bandpass), or notch rejection (reject and Q-circuit). The insertion loss of the cascaded filter is the sum of the individual insertion losses plus an allowance of approximately 0.1 dB for each interconnecting cable.

'FP' Bandpass Filters

- Protect one receiver from front-end overload by carriers of co-located transmitters.
- Suppress IM generation in one transmitter by protecting it further from incoming carriers of co-located transmitters, usually in conjunction with a ferrite isolator.
- Suppress sideband noise of a single transmitter on co-located receiver frequencies
- Generally, "Protect One From Many" principle.

'FR' Notch Filters

- Suppress sideband noise from multicoupled transmitters on one co-located receiver frequency.
- Protect multicoupled receivers further from front-end overload by the carrier of one co-located transmitter
- Generally, "Protect Many From One" principle.

'FQ' Q-Circuit Filters

- Suppress sideband noise of a single co-located transmitter on a closely-spaced receiver.
- Protect a closely-spaced receiver further from front-end overload by the carrier of co-located transmitter
- Suppress IM generation in one transmitter by protecting it further from an incoming carrier of a closely space, co-located carrier.
- Generally, "Protect One From One" at close frequency spacings.

Description

The basic cavity filter is constructed of a 7" diameter aluminum cylinder with a coaxial inner conductor of brass and copper. Silver plating and chromate conversion coatings are used to inhibit corrosion and enhance performance. Temperature compensation is achieved through the use of an invar tuning rod, which results in extremely low frequency drift over the operating temperature range, typically 0.5 ppm/°C.

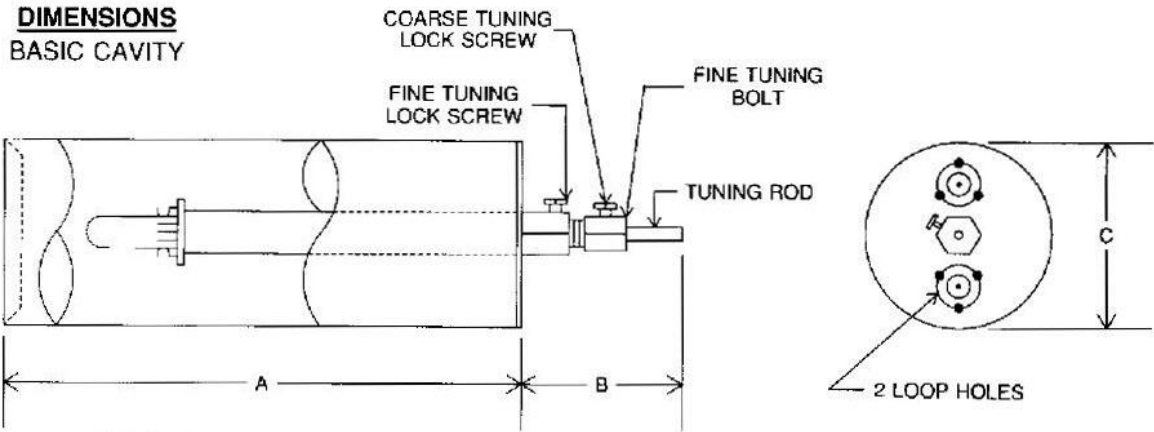

DIMENSIONS: ALL SINGLE CAVITY FILTERS (FP, FR, FQ, SERIES)
 A 5.25 TO 103 - DEPENDING UPON FREQUENCY BAND
 B 5 TO 25 - ADJUSTABLE TO FREQUENCY IN BAND
 C 6.87 OR 10 DIAMETER

**"FP" SERIES
 BAND PASS
 FILTERS**

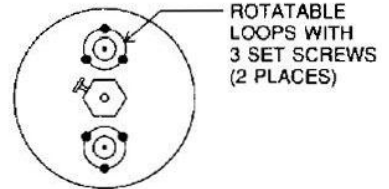
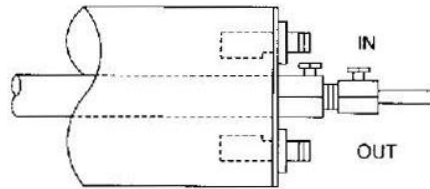

**"FR" SERIES
 NOTCH
 FILTERS**

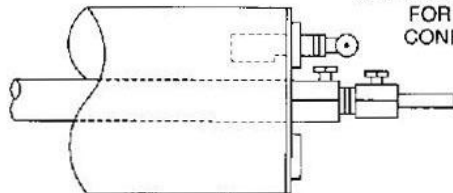

SEE NOTE ON PAGE CI-1053
 FOR VARIOUS "T"
 CONFIGURATIONS

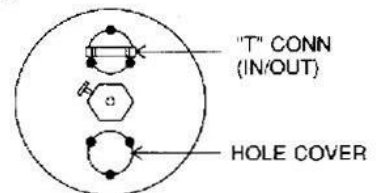

**"FQ" SERIES
 Q-CIRCUIT
 FILTERS**

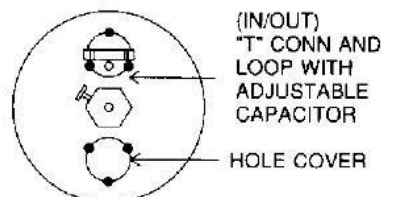
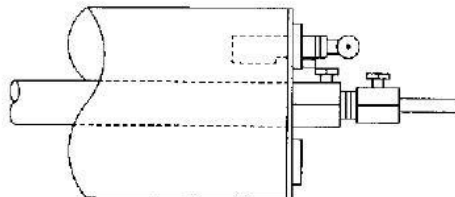

“FP” Series Bandpass Cavity Filters

Electrical Specifications	7" Diameter Cavities												
Notes ---->	FP10107-1	FP10107-2	FP10107-3	FP10107-4	FP10107-5	FP20107-1	FP20107-2	FP20107-3	FP20107-4	FP30107-1	FP30107-2	FP30107-3	FP40137
Frequency Range (MHz)	30-40	40-50	108-136	66-88	88-108	108-136	132-150	148-174	132-174	225-300	300-400	406-512	806-960
Insertion Loss (-dB)	0.5, 1.0, or 3.0					0.5, 1.0, or 3.0				0.5, 1.0, or 3.0			0.75, 1.25, or 2.0
Selectivity	See Curves Below					See Curves Below				See Curves Below			See Curves Below
VSWR	1.5:1 typical at Resonance (Ref to 50 Ohms)					1.5:1 typical at Resonance (Ref to 50 Ohms)				1.5:1 typical at Resonance (Ref to 50 Ohms)			1.5:1 typical at Resonance (Ref to 50 Ohms)
Power Ratings	Note: VSWR may get worse for higher I.L.												
At 0.5 dB	400					400				350			
At 1.0 dB	210					210				185			280 @ 0.75 dB loss
At 3.0 dB	90					90				80			
Temperature Range	-40 to +50 deg C					-40 to +50 deg C				-40 to +50 deg C			-40 to +50 deg C
Termination	Type 'N' Female					Type 'N' Female				Type 'N' Female			Type 'N' Female

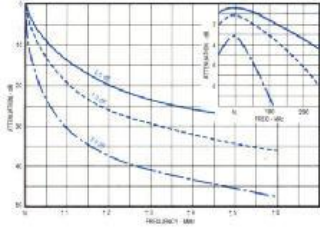

FP10107

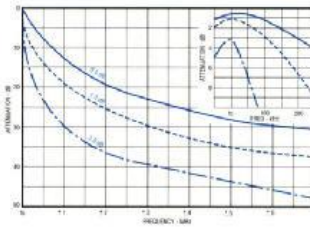

FP20107

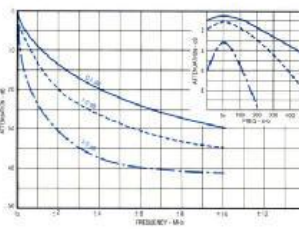

FP30107

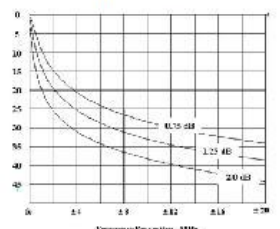

FP40137

10" Diameter Cavities	
FP20110-3	FP30110-3
132-174	406-512
0.5, 1.0, or 3.0	
See Curves Below	
1.5:1 typical at Resonance (Ref to 50 Ohms)	
400	350
210	185
90	80
-40 to +50 deg C	
Type 'N' Female	

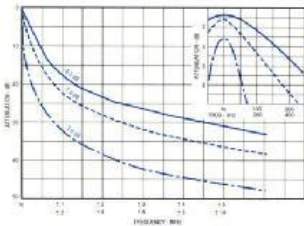

FP20110 & FP30110

“FR” Series Reject Cavity Filters

Electrical Specifications

	7" Diameter Cavities											
	FR10107-1	FR10107-2	FR10107-3	FR10107-4	FR20107-1	FR20107-2	FR20107-3	FR20107-4	FR30107-1	FR30107-2	FR30107-3	
Frequency Range (MHz)	30-40	40-50	66-88	88-108	108-136	132-150	148-174	132-174	225-300	300-400	406-512	
Frequency Separation (KHz)	100				250				500			
Isolation (-dB)	15, 20, or 25				15, 20, or 25				15, 20, or 25			
Insertion Loss (Typ) (-dB)	See Curves Below				See Curves Below				See Curves Below			
VSWR	1.5:1 typical at Resonance (Ref to 50 Ohms)				1.5:1 typical at Resonance (Ref to 50 Ohms)				1.5:1 typical at Resonance (Ref to 50 Ohms)			
Input Power (Max) (Watts)	400				400				400			
Temperature Range	-40 to +60 deg C				-40 to +60 deg C				-40 to +60 deg C			
Termination	Type 'N' Female				Type 'N' Female				Type 'N' Female			

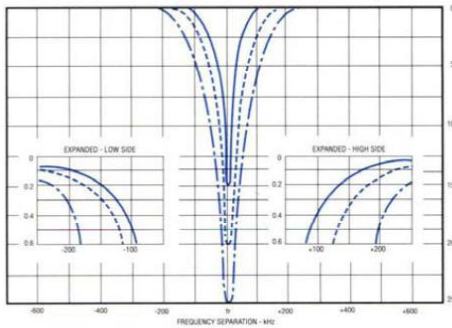

FR10107

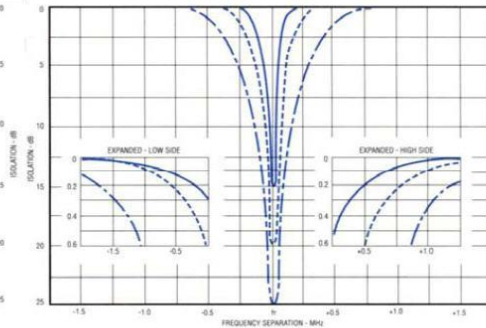

FR20107

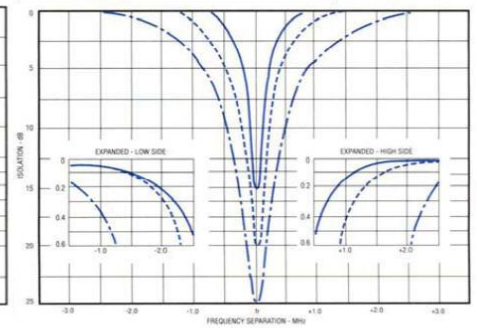

FR30107

“FQ” Series Q-Circuit Cavity Filters

Electrical Specifications

	7" Diameter Cavities									
	FQ10107-1	FQ10107-2	FQ10107-3	FQ10107-4	FQ20107-1	FQ20107-2	FQ20107-3	FQ30107-1	FQ30107-2	FQ30107-3
Frequency Range (MHz)	30-40	40-50	66-88	88-108	118-132	132-150	150-174	225-300	300-400	406-512
Frequency Separation (MHz)	Close 0.25; Moderate 0.5; Wide 2-3				Close 0.25; Moderate 0.5; Wide 2-3			Close 0.25; Moderate 0.5; Wide 2-3		
Attenuation (-dB)	26-40 (Determined by Separation)				26-40 (Determined by Separation)			26-40 (Determined by Separation)		
Insertion Loss (-dB)	0.3 To 1.0 (Determined by Separation)				0.3 To 1.0 (Determined by Separation)			0.3 To 1.0 (Determined by Separation)		
VSWR	1.5:1 typical at Resonance (Ref to 50 Ohms)				1.5:1 typical at Resonance (Ref to 50 Ohms)			1.5:1 typical at Resonance (Ref to 50 Ohms)		
Input Power (Max) (Watts)	350				350			350		
Temperature Range	-40 to +60 deg C				-40 to +60 deg C			-40 to +60 deg C		
Termination	Type 'N' Female				Type 'N' Female			Type 'N' Female		

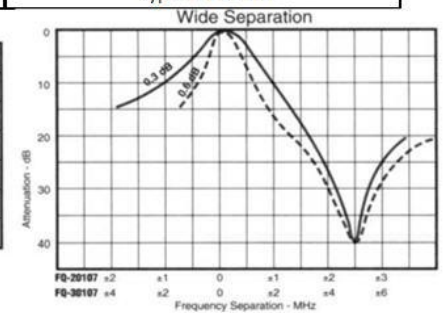
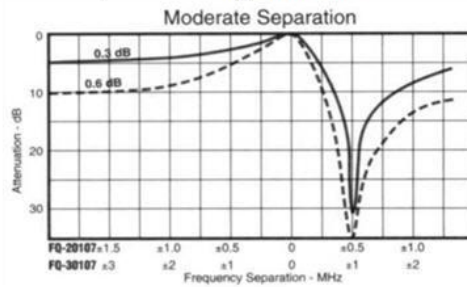
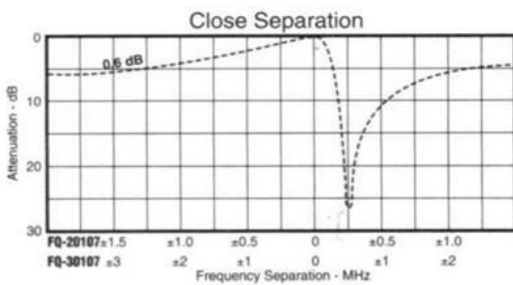

Tuning Instructions

All three "F" Series of the 7, 8.5, and 10" cavity filters can be field retuned across their complete specified frequency range.

The cavities are equipped with adjustable coupling loops to facilitate insertion loss or notch reject changes without removal or replacement of the loop. The loops are locked into place with three holding screws and have been preset at the factory to the customer specifications.

Tools Required:

5/16 Hex or open end wrench

7/8 open end wrench

Phillips head screwdriver

Recommended Equipment (or equivalent)

Network analyzer

Network Analyzer Agilent E5062A

300 KHz - 3 GHz

Sweep generator

Hewlett Packard-Model 8754 Oscilloscope

A/R-6-10 dB, 50 OHM attenuator (pad)

Typical test equipment setups are shown in Figures A and B. Refer to the following pages for tuning of the "FP", "FR", and "FQ" filters.

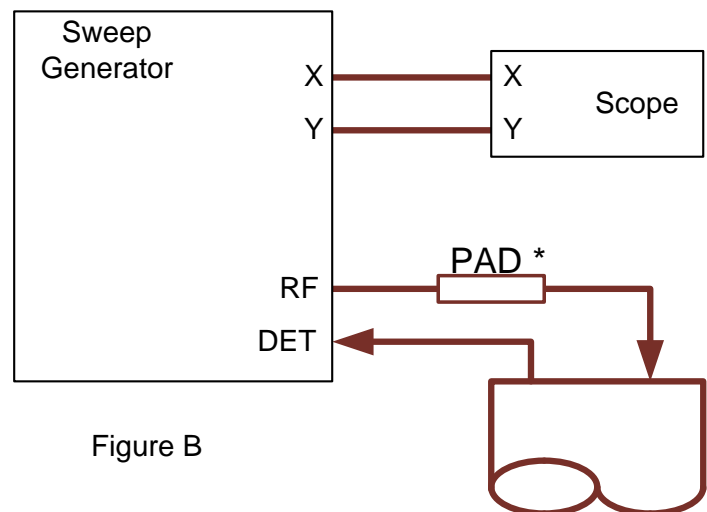
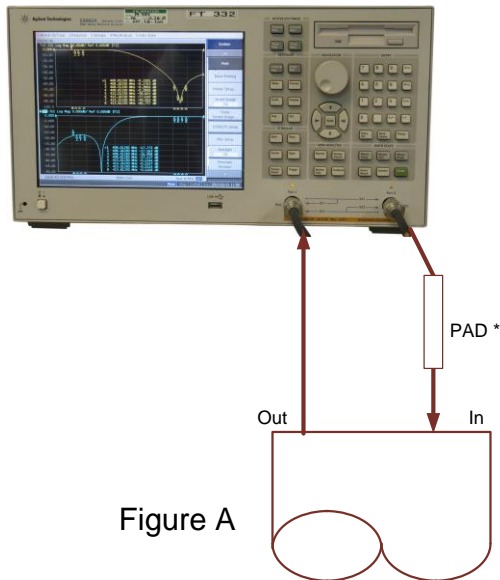

"FP" Series

Bandpass Filter

General Information

Refer to page 5 for tools required and recommended test equipment and setup.

Refer to page 3 for electrical specifications and typical response curves for various models.

The cavity filters are equipped with adjustable coupling loops to facilitate insertion loss settings without removal or replacement of the loops. To change to a new insertion loss other than as was preset at time of delivery, unlock the three holding set screws on each loop and rotate each loop equally to obtain the required insertion loss.

If the insertion loss setting is changed, fine tuning will be necessary because changes in coupling affect resonance.

Tuning Procedure

Each cavity has a coarse tuning adjustment for large changes in frequency and a fine tuning adjustment for small changes in frequency. Coarse tuning is accomplished by unlocking the coarse tuning lock screw and sliding the tuning rod in or out. Fine tuning adjustments are made by locking the coarse tuning lock screw securely and loosening the fine tuning lock screw, and then rotating the fine tuning bolt.

After final tuning, both the fine and coarse tuning lock screws must be tightened down securely

Note: Pushing the tuning rod or turning the fine tuning bolt in lowers the resonance of the filter.

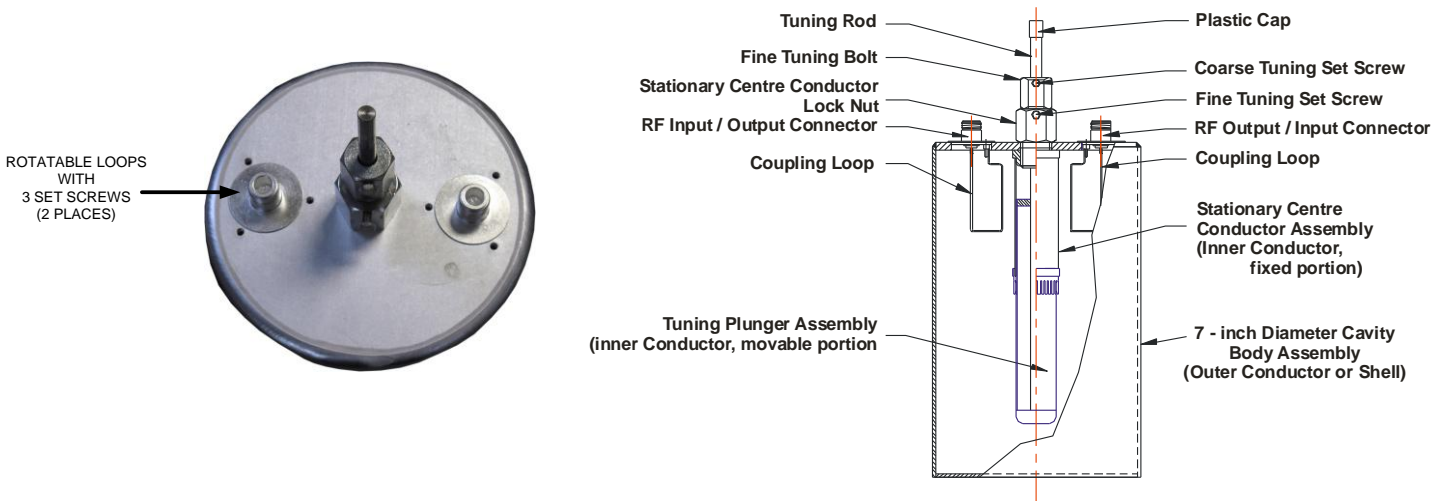

The recommended test equipment for tuning is described on Page 1.

Tuning

1. Connect the test equipment to the RF connectors to measure insertion loss through the cavity.

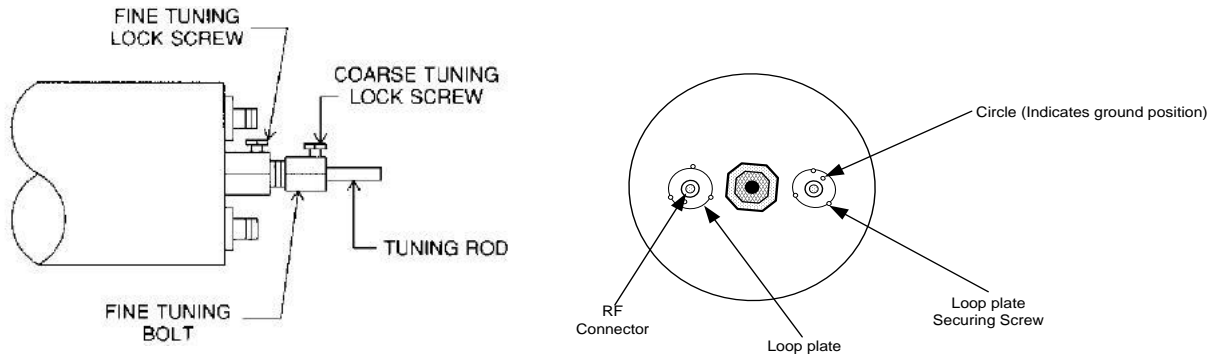

2. Find the existing pass frequency for the cavity.
3. Loosen the plate screws. Turn the loop plates to set the insertion loss for the desired value. Be careful to move the plates in a symmetrical fashion. Moving both loop counter clockwise will increase insertion loss and clockwise will decrease it. When finished both circles should be an identical from minimum. Tighten the plate screws. The return loss at the two ports must be within 1-2 dB of each other.
4. Loosen the top setscrew located on the fine tuning nut.
5. Slide the tuning rod up if the new pass frequency is higher than the existing one and down if it is lower. Move the pass band to the new frequency.
6. Once the operating frequency is close to the desired frequency. Tighten the top setscrew. Do not worry that this tightening will probably cause the pass frequency to shift.
7. Check insertion loss to ensure it is at the desired value as it may drift from the tuning rod adjustment. If the insertion loss is different, repeat step three to get the desired value.
8. Loosen the lower set screw.
9. Using a 7/8" wrench, turn the fine tuning nut to get the unit exactly on frequency.
10. While holding the top nut in position, tighten the lower set screw.
11. Verify the pass band frequency's insertion loss and return loss are as desired and retuning is complete.

Changing the Insertion Loss

- I. Change coupling loop settings first as changes in coupling effect response.
- II. Loosen the 3 screws that secure the loop down (do one loop at a time)

Method 1: rotate each loop equally to obtain the required insertions loss.

Method 2: rotate each loop to obtain equal reject notch depths. Approximate settings:

Attach tee to one loop and leave the other loop open.

Rotate loop until the insertion loss trace shows a notch with the depth that corresponds to the desired pass band insertion loss.

14 dB notch = 0.5 dB IL
10 dB notch = 1.0 dB IL
4.5 dB notch = 3.0 dB IL

- III. After the loops have been set, make minor adjustments to the loop positions to obtain approximately equal return losses on each loop.

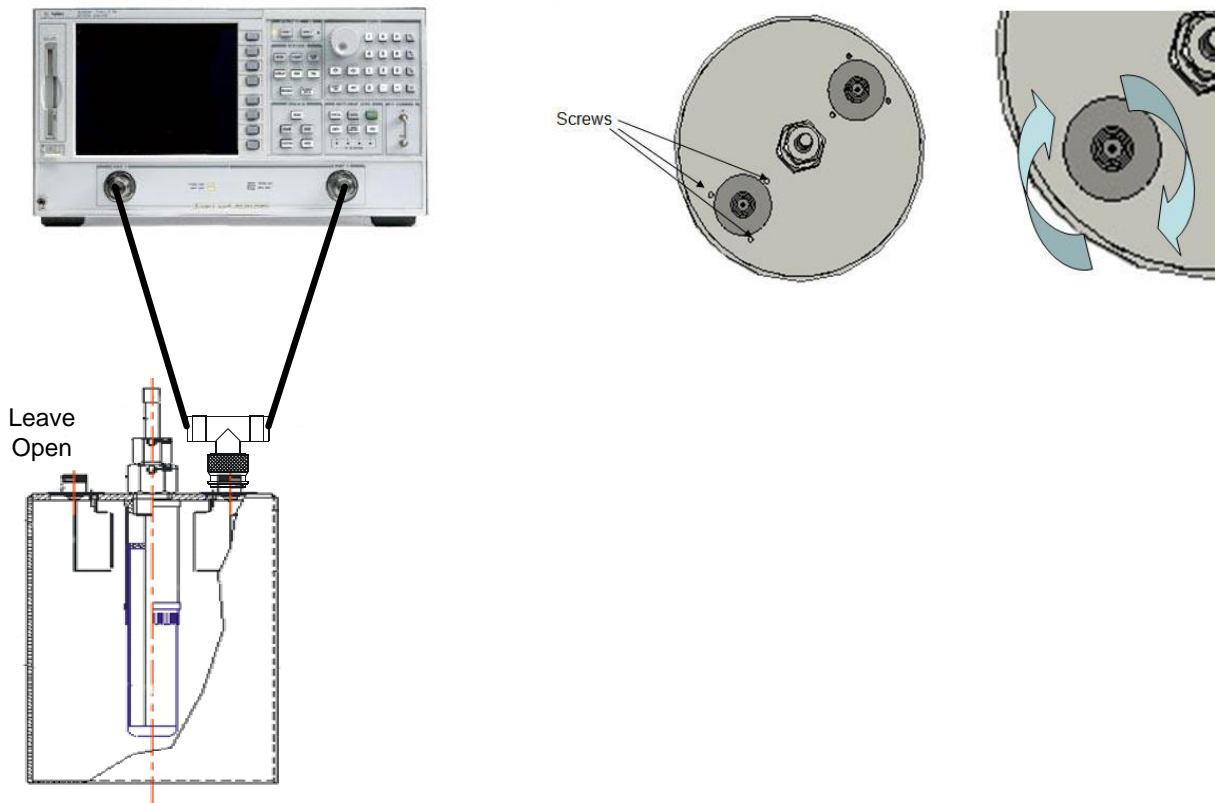

- IV. Fine tune each loop until the return loss at each port is equal and the insertion loss is at the desired level.
- V. If the frequency has shifted during the loop adjustment, restore the resonant frequency of the cavity using the tuning rod.

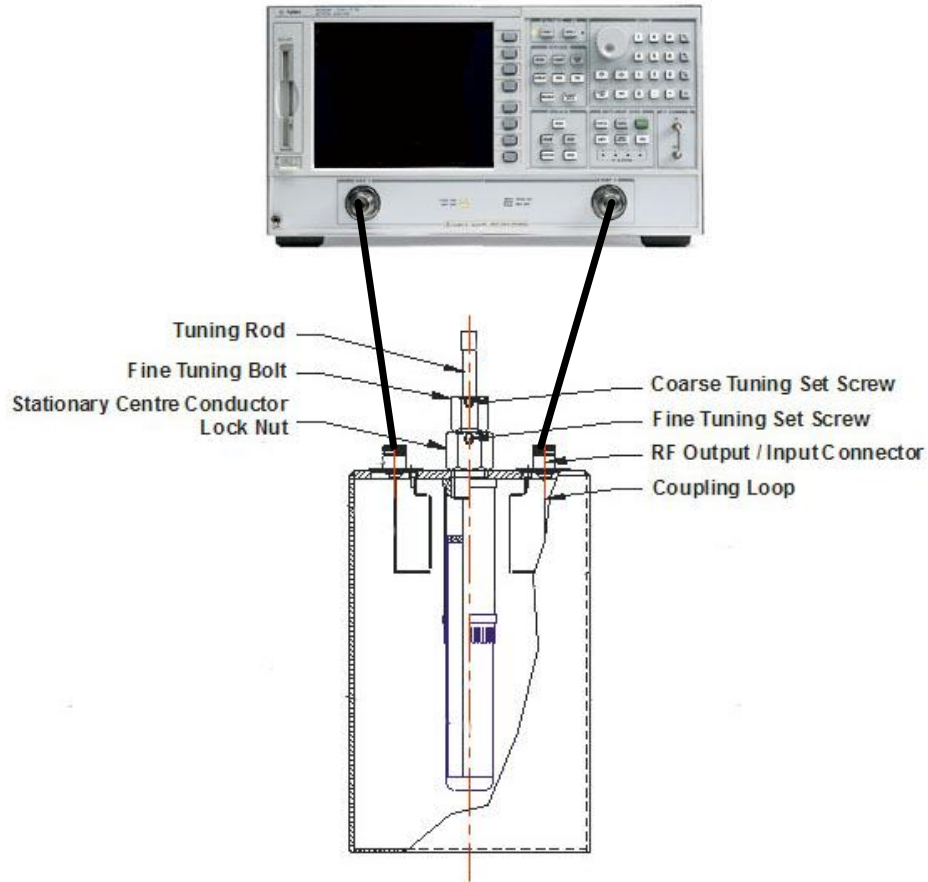

"FR" Series

Notch Filters

General Information

Refer to page 5 for tools required and recommended test equipment and setup.

Refer to page 3 for electrical specifications, typical response curves, and the various input and output configurations which are required to obtain the passbands optimized above, below or equally with reference to the notch frequency. The various response paths are determined at the factory by the input and output configurations at the time of order and should not be changed.

A notch or rejection null is created at the unwanted frequency by adjusting the cavity tuning rod.

The insertion loss at the frequency to be passed is optimized by the type of response path used.

The amount of notch attenuation is dependent upon the size and position of the coupling loop, which is a factory adjustment. If a change in the field is required, loosen the 3 set screws holding the loop and rotate the loop to the desired notch depth. Then lock the loop back into place with the 3 set screws.

Tuning Procedure

Each cavity has a coarse tuning adjustment for large changes in frequency and a fine tuning adjustment for small changes in frequency. Coarse tuning is accomplished by unlocking the coarse tuning lock screw and sliding the tuning rod in or out. Fine tuning adjustments are made by locking the coarse tuning lock screw securely and loosening the fine tuning lock screw, and then rotating the fine tuning bolt.

After final tuning, both the fine and coarse tuning lock screws must be tightened down securely.

Note: Pushing the tuning rod or turning the fine tuning bolt in lowers the resonance of the filter.

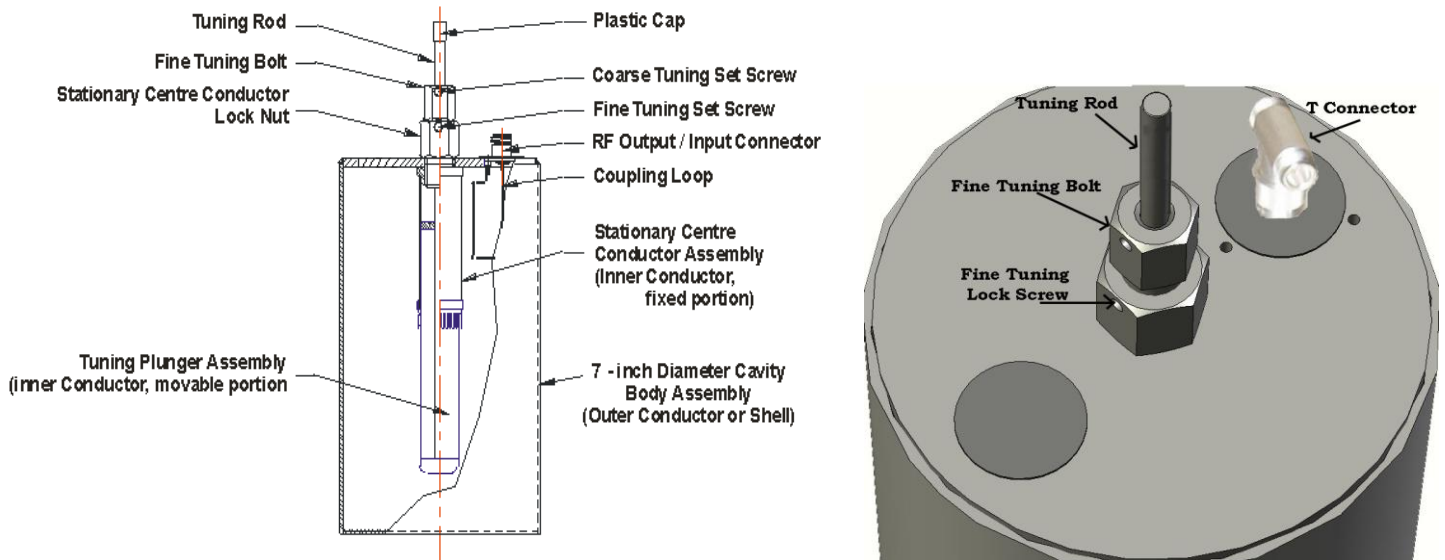

TYPICAL EXAMPLES:



TYPICAL CURVES SHOWN ARE FOR MODEL FR-20107 (132-174 MHz)

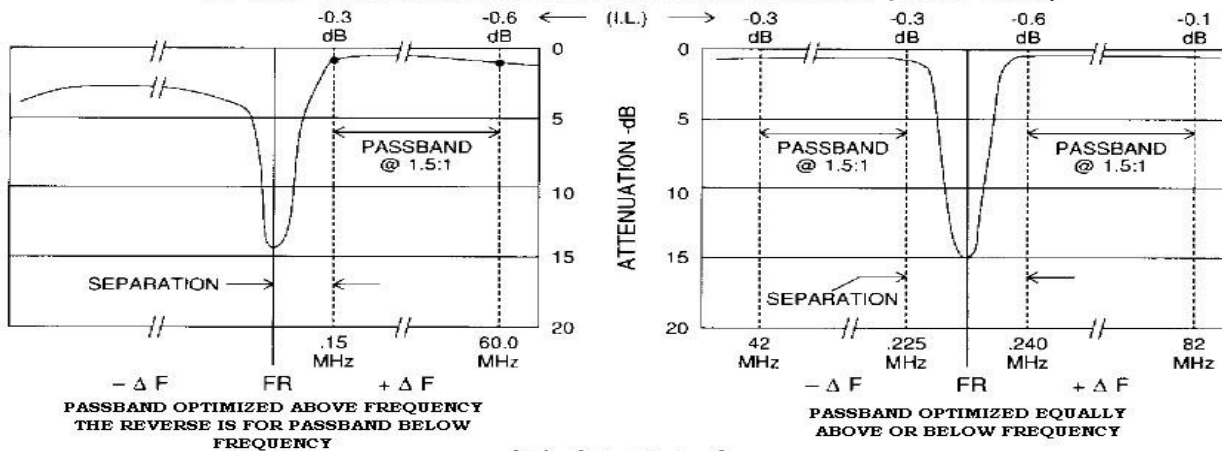

15 dB Notch

Tuning procedure is the same as for a bandpass cavity. The only difference is that a T connector must be used since there is only one loop. At VHF a cable is placed between the tee and the loop.

Tuning

- I. Connect network analyzer to both ports of the T connector.
- II. Unlock coarse tuning locknut
- III. Move rod in to decrease resonant frequency out to increase.

Optional: Lock coarse tuning bolt, unlock fine tuning bolt and rotate fine tuning nut to change frequency.

Changing the Insertion Loss

- I. Loosen the 3 screws that secure the loop down (do one loop at a time)
- II. Rotate loop to obtain the required attenuation.
- III. Tighten all screws.

"FQ" Series Q-Circuit Filters

General information

Refer to page 5 for tools required and recommended test equipment and setup. Also need a small chisel bladed screwdriver with a fine point to adjust the capacitor.

Refer to page 4 for electrical specifications and typical response curves for various models.

The cavities are equipped with an adjustable coupling loop to facilitate insertion loss setting. The loop also has a variable capacitor attached which is externally adjusted to tune to the reject frequency either high or low. The size and position of the loop determines the insertion loss of the filter. The loop is preset at the factory as determined at time of order. To change to a new insertion loss, unlock the three holding set screws on the loop and rotate it to the new insertion loss required.

Tuning of the pass frequently is accomplished by adjusting the tuning rod. Pushing the tuning rod or the fine tuning bolt in lowers the pass frequency of the filter. The capacitor is adjusted to obtain either the low or high pass reject frequency.

Tuning Procedure

The cavity has a coarse tuning adjustment for large changes in frequency and a fine tuning adjustment for small changes in frequency at the passband required. Coarse tuning is accomplished by unlocking the coarse tuning lock screw and sliding the tuning rod in or out. Fine tuning adjustments are made by locking the coarse tuning lock screw securely and loosening the fine tuning lock screw, then rotating the fine tuning bolt, for maximum signal.

To tune to the reject frequency, remove the cover from the capacitor located on the loop and adjust the capacitor for minimum signal at the reject frequency.

The tuning of the rod and capacitor should be repeated until both passband and reject frequencies are obtained.

After final tuning, both fine and coarse tuning set screws must be tightened down securely and the capacitor cover is to be replaced.

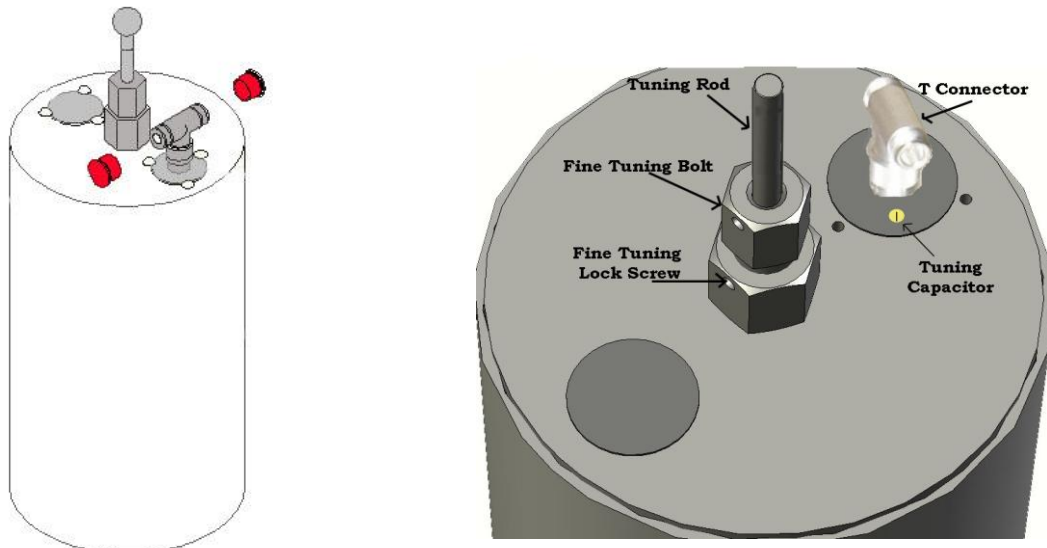

Typical Curves for 0.6 dB Insertion Loss (VHF)

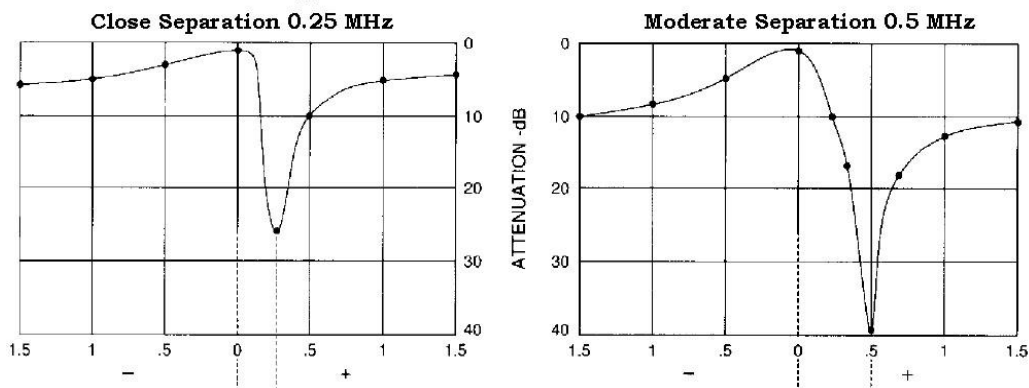

1. Connect the test equipment to the RF connectors to measure insertion loss through the UG-107 'Tee' connector.

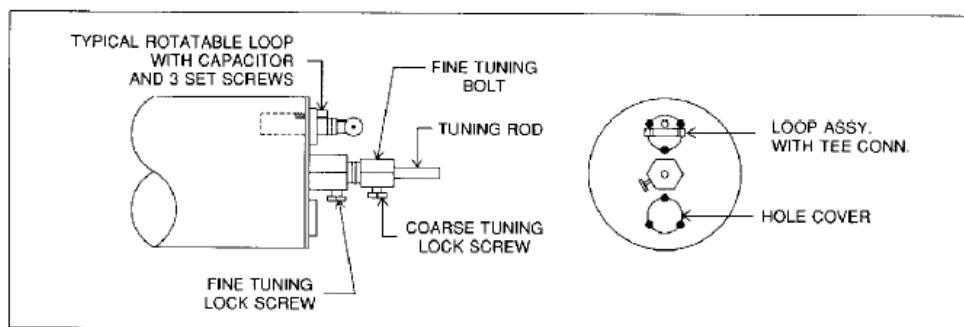

2. Loosen the upper set screen located on the fine tuning nut and move the tuning rod to get the desired pass frequency. Raising the tuning rod will give a higher pass band and lowering it will lower the pass band. Tighten the upper set screw to set the tuning rod.
3. Loosen the lower set screw and turn the fine tuning nut with 7/8" wrench to fine tune the pass band. Since the pass band slope's insertion loss is quite shallow, fine tuning is better done by observing the return loss at the pass band. Tighten the lower set screw once the pass band frequency is set.
4. Turn the capacitor set screw to position the notch at the desired reject frequency. If the notch cannot be positioned, a different loop may be required.
5. Measure the depth on the notch to ensure it provides a suitable level of attenuation. If a greater level of attenuation at the notch is desired, turn the loop plate counter clockwise to increase the depth of the notch. Note that this procedure will have the effect of increasing the pass band insertion loss as well. This effect is most noticeable when the reject frequency is close to the pass frequency. This procedure has minimal effect with wider spacing of the reject band.
6. Verify that the pass and reject insertion losses and the return loss of the pass band are suitable and the retuning is complete.