

Curtain Track

**5 YEAR
MANUFACTURER
WARRANTY**

Product benefits:

- » Smooth, quiet and fast operation
- » User friendly
- » Auto commissioning function – sets it's own limits – simple & time saving
- » Auto open and close when the curtain fabric is drawn by hand
- » Manual over-ride when power is off – recommissions automatically when powered on again
- » Integrates on all Motolux controls, so can be used with Motolux roller, roman and cellular blind motor systems – see more information on the controls here
- » 240v power – no transformers required
- » Dry contact input for easy integration with automation systems (C-Bus, Dynalite)
- » Remote and Automation system simultaneous control possible
- » Tandem configuration possible
- » Five year manufacturer's warranty

Safety features:

- » Overload and over-temperature protection in-built

Mounting and installation:

- » Maximum curtain width 12 metres (39feet) using track joiners
- » Track is bendable to minimum radius 350mm (14") right angle bend
- » Suitable for light to heavy weight curtains up to 90kg (198lbs) fabric weight
- » Suitable for either wall mount (with installation bracket) or top fixing using butterfly clips

RF Features:

- » Fully electronic programming and operation
- » Radio remote control handset or fixed wall switch
- » Automation system compatible as standard, including simultaneous use of remote control
- » Easy programming with independent setting of channels and limits
- » Remote operation up to 30 metres (100feet) inside buildings and up to 100 metres (300 feet) in open areas
- » Individual or group motor control, with up to 11 channels per remote and 24channels per motor

Technical Specifications:

Model	MC02-70-240/50
Voltage	240V/50Hz
Current	300mA
Power	70W
Speed	110rpm
Operating Cycle	4min continuous
Radio Frequency	433.92
Operating Distance	30 meters indoor
Max Track Length	12 meters
Tandem Motor Option	Yes
Motor Weight	1.4kg
Motor Dimensions	L50 x W60 x 295mm

Connections:

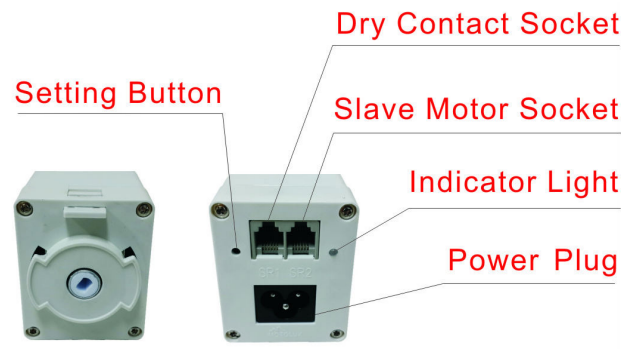

Wiring:

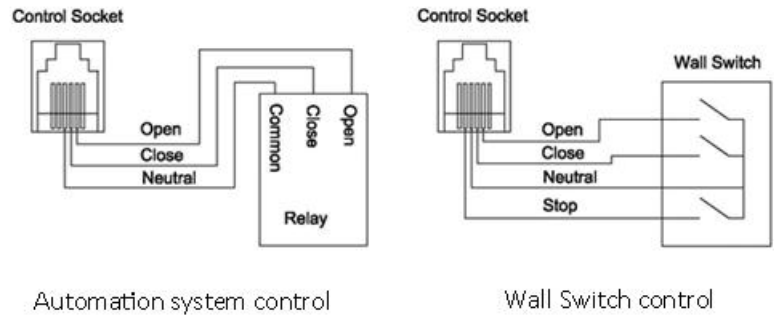

Ordering information
 Australia/New Zealand
 +61 (0)3 9876 0400
 sales@motolux.com.au
 www.motolux.com.au

Motolux is a world-class manufacturer of motorisation products and systems dedicated to window covering markets worldwide. A designer and manufacturer of a fully integrated range of motorisation solutions, Motolux products are suitable for commercial or residential use. Our high quality product range is streamlined to simplify the process of manufacturing, installation and ongoing maintenance of almost any type of motorised window covering product.

- ✦ Powerful quiet AC motor.
- ✦ Matching Trietex tracking system.
- ✦ One step limits setting.
- ✦ Soft start/Motor running can be started when curtain is drawn by hand.
- ✦ Curtain can be hand-traversed when the power is off.
- ✦ Slave motor can be operated.
- ✦ Built-in radio receiver, dry contact and RS485 interface.
- ✦ Integrates on same remote control with Motolux roller blind, Roman and Cellular blind motor systems
- ✦ Available as pre-fabricated motorised tracks in certain market

MOTOR VIEW



FITTING INFORMATION

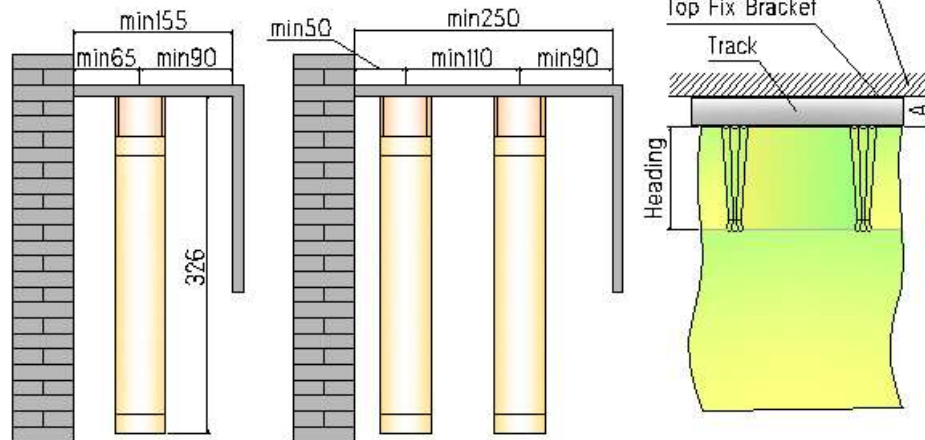

Dimension Unit: mm Please keep the minimum sizes as requested.
 The fabric should be lace or voile for the inside one of double tracks.
 A = 130mm – Heading, Heading = 90 or 100mm, Curtain Hook No.: 71

CONFIGURATION

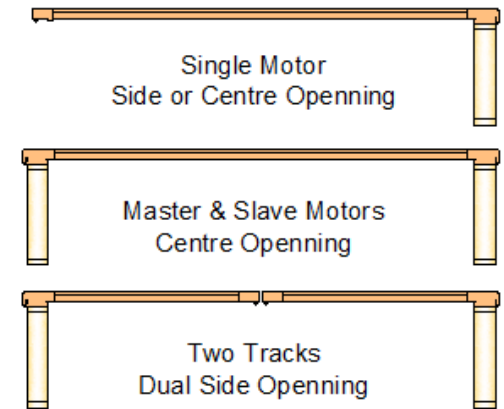

LOADING CHART

Headrail Status	4m	6m	8m	10m	12m
Side or Centre Opening	70	55	40	25	10
Master & Slave Motor	80		70		
Gently Curved Headrail	60	45	30	15	NA
Master & Slave Motor	70		60		
Radius 350mm Side or Centre Opening	55	40	25	10	NA
Radius 350mm Master & Slave Motor	65		55		
Radius 350mm Side or Centre Opening	30	15	NA		
Radius 350mm Master & Slave Motor	40		30		

MOTOR SPECIFICATION

Model	MC02-70-240/50
Voltage	240V/50Hz
Current	300mA
Power	70W
Speed	110rpm
Operating Cycle	4min continuous
Radio Frequency	433.92
Operating Distance	30 meters indoor
Max Track Length	12 meters
Tandem Motor Option	Yes
Motor Weight	1.4kg
Motor Dimensions	L50XW60X295mm

Ordering information

Australian / New Zealand
 +61 (03) 9876 0400 sales@motolux.com.au