

ULTIMATE GOURMET GRILL **USER GUIDE**

IMPORTANT SAFEGUARDS

When using an electrical appliances, basic safety precautions should always be followed, including the following:

1. **IMPORTANT:** Read all instructions carefully before first use.
2. Do not touch hot surfaces. Use handles or knobs.
3. To protect against electrical hazards, do not immerse cord, plugs, or the appliance in water or other liquid.
4. This appliance is not intended for use by persons (including children) with reduced physical, sensory or mental capabilities or lack of experience and knowledge, unless they have been given supervision or instruction concerning the use of the appliance by a person responsible for their safety.
5. Close supervision is necessary when any appliance is used by or near children. Children should be supervised to ensure that they do not play with the appliance.
6. Unplug from outlet when not in use and before cleaning. Allow to cool before putting on or taking off parts, and before cleaning the appliance.
7. Do not operate any appliance with a damaged cord or plug or after the appliance malfunctions, or is dropped or damaged in any manner. Return appliance to the manufacturer for examination, repair or electrical or mechanical adjustment. All servicing, other than cleaning, should be performed by an authorized service representative. See Warranty section.
8. The use of accessories or attachments not recommended by GreenPan may cause hazards.
9. Do not use outdoors.
10. Do not let cord hang over edge of table or counter, or touch hot surfaces.
11. Do not place on or near a hot gas or electric burner, or in a heated oven.
12. Extreme caution must be used when moving an appliance containing hot liquids.
13. To disconnect, turn any control to 'MIN', then remove plug from wall outlet.
14. Do not use appliance for other than intended use.
15. Do not leave unit unattended while in use.

SAVE THESE INSTRUCTIONS FOR HOUSEHOLD USE ONLY

POLARIZED PLUG

This appliance has a polarized plug (one blade is wider than the other). To reduce the risk of electric shock, this plug will fit in a polarized outlet only one way. If the plug does not fit fully in the outlet, reverse the plug. If it still does not fit, contact a qualified electrician. Do not modify the plug in any way.

A short supply cord is provided to reduce the hazards of becoming entangled in or tripping over a long cord. Extension cords may be used if care is exercised in their use. If an extension cord is used, the marked electrical rating of the detachable power-supply cord or extension cord should be at least as great as the electrical rating of the appliance. If the appliance is of the grounded type, the extension cord should be a grounded 3-wire cord. The extension cord should be arranged so that it will not drape over the counter top or table top, where it can be pulled on by children or tripped over

HEALTHY COOKING STARTS WITH GREENPAN

Since inventing healthy ceramic nonstick in 2007, we've dedicated ourselves to unique advances that make cooking better for everyone. From healthy ceramic nonstick cookware to revolutionary home appliances, our groundbreaking designs deliver remarkable performance so you can focus on the flavor. Enjoy!

CONTENTS

- 02 Important Safeguards**
- 03 About GreenPan**
- 04 Parts**
- 04 Features & Benefits**
- 04 Instructions for before first time use**
- 05 Assembly, Operation**
- 05 Using Ultimate Gourmet Grill**
- 05 Tips & Hints**
- 07 Recipe Ideas**
- 09 Cleaning and Maintenance**
- 10 Troubleshooting**
- 11 Warranty**

PARTS

- A. Grill Plate
- B. Teppanyaki Grill
- C. Handles
- D. Power Cable With Plug (Not Shown)
- E. Indicator Light
- F. Pancake Griddle
- G. Temperature Control Knob
- H. Eight Mini Pans
- I. Eight Spatulas

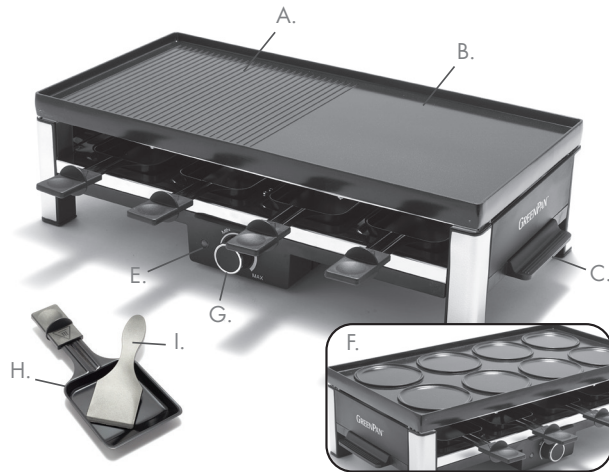

FEATURES AND BENEFITS

- 1. Grill Plate – Make beef, chicken, sausage, shrimp, veggies, and more.
- 2. Griddle Plate – Make teppanyaki, burgers, onions, peppers, bacon, and eggs.
(Reversible Grill/Griddle (A&B) and Pancake Griddle (F) coated with Thermolon Volt Coating).
Thermolon Volt Healthy Ceramic Nonstick – Our diamond-infused nonstick is specially designed for home appliances and free of PFAS, PFOA, lead & cadmium
- 3. Handles (C) – Simple and portable, these nylon side handles make it easy to take the Ultimate Gourmet Grill where the party is.
- 4. Power Cable with plug – 5’ long
- 5. Indicator Light – Illuminates in green and turns off once the Ultimate Gourmet Grill has reached the right temperature.
- 6. Pancake griddle - Make eight pancakes at once.
- 7. Temperature Control (min-max) – Dial in the right temp for your meal.
- 8. Eight Mini Pans - Each person gets their own pan that’s crafted from durable carbon steel and finished with a nonstick coating. Melt cheese, chocolate, bananas. You can even toast bread.
- 9. Eight Spatulas – Designed to be used with the mini pans, these spatulas are perfect for when you want to scrape off melted cheese from mini pan.

BEFORE FIRST USE

- Take the Ultimate Gourmet Grill and accessories out of the box and dispose of all the packaging.
- Before appliance is used, the Ultimate Gourmet Grill, the power cable, and the accessories must be carefully checked for any defects.
- Clean the Ultimate Gourmet Grill and accessories with a damp cloth before you use the appliance for the first time. Never use abrasive cleaning agents.
- Insert the plug into the socket. Please note: before connecting the appliance, make sure the appliance’s voltage corresponds with the local power supply 120 volt AC wall outlet.
- Turn the thermostat clockwise to the desired setting and allow the appliance to heat up (without the mini pans) for at least 5-10 minutes without placing food on the griddle. The green indicator light will turn off once the gourmet set has reached the selected temperature.
- When the appliance is turned on for the first time, it may produce minor smoke or you may notice the faint smell of smoke. This is normal. Make sure the room is properly ventilated. The smoke and the smell are temporary and will soon stop.
- We recommend that you place a heatproof table mat between your table and the appliance to avoid potential damage to your table or tablecloth.
- Place the appliance in a properly vented room.

ASSEMBLY

1. Place Reversible Grill/Griddle plate on top of housing.
2. Place your 8 Mini Pans and Spatulas near unit.
3. Do all your food prep.
4. Plug in the Ultimate Gourmet Grill.
5. Turn on the unit.
6. Add the Mini Pans with food after unit has heated.

OPERATION

The GreenPan Ultimate Gourmet Grill is a fun and healthy way to cook meats, fish and vegetables in minutes! Celebrated in Europe, the art of cooking raclette encourages you and your guests to create simple yet delicious meals together.

Delight in fresh foods hot off the grill while enjoying the party atmosphere the Ultimate Gourmet Grill creates. Explore a delicious array of options as you and your guests prepare everything from full meals to appetizers such as cheese on potatoes, toast, or grilled tomatoes. Every dish can be as unique as the person preparing it! It's easy to use and a snap to clean. Try the included recipes as an introduction to this exciting cooking method... and have fun!

USING YOUR ULTIMATE GOURMET GRILL

- Place the base on a flat level surface.
- NOTE: Ensure that the area being used is well ventilated. Be careful of splattering fat or juice when grilling foods.
- Position the reversible grill/griddle plate over the heating element on the grill supports. Use the smooth side for warming, preparing fondue or breakfast foods, etc. Use the ridge side for grilling meats, fish, or vegetables.
- Heat the appliance for a few minutes on the highest setting until the green indicator light goes out.
- Rub your chosen cooking oil on the grill/griddle.

- Use the knob on the thermostat to select the desired temperature. In most cases, grilling should be done between the last three largest dots. The temperature may be adjusted during cooking for optimum cooking results.
- The Mini Pans can be moved on and off the Lower Plate as food is cooked and served.
- NOTE: Be sure to place the hot Mini Pans on a heat-resistant surface when removed from the Grill.
- Do not cut food on the Reversible Plate or in the Mini Pans as this may damage the coating.
- Never place empty Mini Pans on the appliance during use.
- To avoid damage to the Mini Pans, use only the spatulas supplied with them.
- When cooking is complete, turn the Temperature Control Dial counterclockwise to the smallest dot position on the left and remove plug from wall outlet.
- Do not move the unit until it is completely cool. Remove the Mini Pans before moving to prevent them from falling from the Lower Plate.
- Warning! The handles of each Mini Pan are marked with a triangle to indicate that you should not touch that part of the handle while using the Ultimate Gourmet Grill, as it can get very hot.

TIPS & HINTS

Before preheating the Grill Plate, use a paper towel moistened in 1 tbsp. (15 ml) of an oil with a high smoke point and spread on cooking surface of Grill Plate and inside Mini Pans.

- Always preheat the Grill for 10 minutes.
- DO NOT use metal utensils to place food on or remove food from the Grill Plate. This may scratch the nonstick Grill Plate.
- Use the Spatulas included with the appliance to remove food from the Mini Pans.
- Never cut food directly on the Grill Plate or in the Mini Pans.
- When using the Mini Pans on top of the Grill Plate, place gently, so they do not scratch the Grill Plate.

ULTIMATE GOURMET GRILL GENERAL USES

Top Grill/ Griddle Plates	Food Preparation	Guidelines
Top Grill/ Griddle Plates	<p>Grill meats, fish, poultry, seafood, and vegetables.</p> <p>Vegetable suggestions; cherry tomatoes, peppers, mushrooms, sweetcorn niblets, cauliflower, broccoli, potatoes, cornichons, and olives.</p> <p>Seafood suggestions; scallops, salmon, shrimp.</p>	<p>Spread a little butter or an oil with a high smoke point on the Grill Plate. Preheat.</p> <p>Place food on Grill Plate.</p> <p>Grill food according to taste. Turn food from time to time.</p> <p>Grilling time depends on the type of food, initial temperature, and thickness.</p> <p>Do NOT cut food directly on the grill.</p>
Griddle Plate	Scrambled or fried eggs, bacon, thinly sliced, ham, brown meat, poultry, and seafood.	
Pancake Griddle	Individual pancakes, crepes, mini egg bites.	

Raclette Pans	Food Preparation	Guidelines
Grill & Fondue	Grill meat and vegetables on top of Grill Plate and use Mini Pans to melt cheese and chocolate.	Do NOT use with hot oil.
Broil	<p>Raclette cheese, raw eggs, bread, vegetables, thinly sliced meats or shrimp.</p> <p>Alternative cheeses; Mozzarella, Cheddar, Gouda, Brie, Gorgonzola, Blue Cheese and Feta.</p>	<p>Place food in Mini Pans. Position Mini Pans on lower base rack and broil to taste, and texture. Keep watch.</p> <p>Melted cheese can be spread on grilled food or bread.</p>
Desserts	Fruits, flambe, bananas, pears, pineapple, mango, grapes, figs. Thinly sliced cake sprinkled with liquor.	<p>Place food in Mini Pans. Pre-cut fruit into slides.</p> <p>Do NOT cut on the grill plate.</p> <p>Sprinkle fruit or cake with sugar and position Mini Pans on lower base rack. Keep watch.</p>

RECIPES IDEAS – A GUIDE TO YOUR PERFECT PARTY!

There is an enormous choice of suitable meats, ranging from small sausages to brochettes, chicken and fish, which can all be cooked on the Grill Plate. Smaller pieces of food can also be cooked in the Mini Pans. Please use the following recipes as a guide.

Raclette-Style Cheese

- 1-1/2 cups (375 ml) shredded processed* Gruyere cheese
- 1 cup (250 ml) shredded Gouda Cheese
- 1 tbsp (15 ml) snipped fresh basil or oregano
- 2 tsp. (10 ml) Dijon-style mustard
- 1 tsp. (5 ml) white wine
- Worcestershire sauce, to taste
- Tabasco sauce, to taste
- Blanched cauliflower and/or broccoli flowerets
- Halved tiny new potatoes
- Pita bread wedges

1. In a small mixing bowl combine cheeses; let stand to soften. Add basil or oregano, mustard, wine and Worcestershire and Tabasco sauces. Beat with an electric mixer on low speed until well combined; (mixture will be crumbly). Form into a ball about 4" (10 cm) round by 1 inch (2.5 cm) high. Wrap in clear plastic wrap. Chill several hours or overnight.
2. Preheat the Grill. Unwrap cheese round and cut into wedges. Place the wedges in mini Raclette Pans. Place Pans on Lower Plate and melt cheese until softened and heated through. Check often to make sure the cheese doesn't over-melt (the cheese shouldn't lose its shape or start to run).
3. Grill vegetables and potatoes on the Grill Plate while cheese is melting.
4. Serve cheese with warm vegetables and pita bread.

*It is important to use processed cheese. Processed cheese melts smoothly, giving an acceptable texture.

Pears Savoy-Style

- Pears, thinly sliced
 - Butter
 - Sugar
 - Cream
1. Preheat Grill.
 2. Peel, halve and core pears, then thinly slice.
 3. Melt butter in mini Raclette Pans on the Lower Plate.
 4. Place pears in the mini pans sprinkle with sugar. Place mini Raclette Pans on top of Grill Plate and cook for a few minutes until pears turn soft. Pour some cream over pears and place Raclette Pans on the Lower Plate. Cook gently until the sauce is slightly caramelized.

French Toast

- 4 eggs
 - 1/2 tsp. (3 ml) salt
 - 3 tbsp. (45 ml) sugar
 - 1-1/3 cups (335 ml) milk
 - 8 slices day old bread
 - 1 tbsp. (15 ml) unsalted butter – divided
1. Preheat the grill for 10 minutes with the smooth grill plate facing up. Then turn the Temperature Control to a medium setting. While the grill is preheating, combine eggs, salt, sugar and milk in a shallow baking dish. Blend thoroughly.
 2. Put a small amount of butter on the grill plate and spread with a plastic or wooden spatula.
 3. Soak bread in egg mixture, turning once to coat both sides. Place on the grill plate and cook until golden brown, turning once so both sides are cooked. Serve immediately or place in oven to keep warm.

NOTE: Do not soak bread until ready to cook or the bread will break apart.

Grilled Pound Cake with Grilled Fruit and Vanilla Ice Cream

Fun to eat, and easy dessert for any occasion.

- 2 Tbsp. Butter
- 2 Tbsp. Brown Sugar
- ¼ tsp. Vanilla
- 1/8 tsp. Ground Cinnamon
- ¼ cup Canola Oil
- 4 thick slices Pound Cake
- 4 Honey Glow Pineapple slices
- 2 Peaches, sliced
- Optional Vanilla Ice Cream, and Caramel Sauce, warmed for drizzling.

1. Melt butter over a low heat and stir in brown sugar, vanilla and cinnamon. Whisk until smooth and keep warm.
2. Brush pineapple rings and peach slices with canola oil on both sides. Grill until golden brown, about 3 minutes per side.
3. Grill Pound Cake slices until lightly golden on each side.
4. Brush the cake slices with the butter-brown sugar mixture while still warm.
5. Top each cake slice with the pineapple and peach slices.
6. Serve each a scoop of ice cream and a drizzle of caramel sauce.

Pineapple, peaches and pound cake should be all presliced. Grill them on top of the grill/griddle plate. Butter mixture can be made separately on top of your stove top. You can also divide the mixture and pour in each mini raclette pan to keep warm.

LITTLE BITES

Mediterranean Raclette Pan

- 4 olives, sliced
- 1 slice, raclette cheese*
- 1 slice, tomato
- 1/4 red pepper, slices

Add the olives, pepper, tomatoes in your mini raclette pan. Season with a little rosemary.

Cover with a slice of raclette cheese and place under the raclette grill. Once the cheese bubbles the pan is ready to eat.

Tomato and Cornichon Raclette Pan

- 4 cherry tomatoes, cut in halve
- 2 cornichons
- 1 slice raclette cheese*

Place the tomatoes and cornichons in your raclette pan. Cover with a slice of raclette cheese and place under the raclette grill. Once the cheese bubbles the pan is ready to eat.

Pear, Onion and Zucchini

- 1/4 pear, thinly sliced strips
- 1 tsp sliced onion
- 1 slice raclette cheese*

Grill zucchini and onion on top grill. Place the onion and pear slices in the mini pan. Lay the sliced zucchini on top of the raclette grill. Cover with a slice of raclette cheese and place under the raclette grill. Once the cheese bubbles the pan is ready to eat.

Hawaiian Raclette Pan

- 2 slices bacon
- 2 tbsp pineapple chunks
- 1 tbsp sweetcorn niblets
- 1 slice raclette cheese*

Cook bacon on top griddle. Place pineapple chunks and sweetcorn in your raclette pan. Add a piece of bacon. Cover with a slice of raclette cheese and place under the raclette grill. Once the cheese bubbles the pan is ready to eat.

Raclette Cheese*

Raclette cheese is traditionally made from cow's milk, although you can also find some varieties made from sheep's milk.

Raclette cheese is a semi-hard cheese which is thickly sliced (less than 1 cm) and used for melting and grilling; it is not intended to be eaten raw. The mild varieties have a characteristic pungency, for the cheese-lover.

SO MANY WAYS TO COOK WITH THE ULTIMATE GOURMET GRILL

Traditional raclette is fun, but there are so many other ways to cook!

FIESTA PARTY – Make your favorite fajitas! Grill chicken, meat, seafood, and veggies. Make a queso dip in the mini pans and dip your taco chips for the perfect nachos. Grill or heat your tortillas for a final touch. Assemble fajitas your way, hot or spicy with your favorite salsa, hot sauce and guacamole.

BURGER BAR – Grill burgers your way! Add all your favorite fix-ins—bacon, onion, melted cheese, and more. Grab the chips and a pickle and assemble your burger. Someone pass the ketchup, please!

BRUNCH – Perfect for Sunday brunch or a special shower event. Eggs fried, scrambled or sunny-side up. Add some bacon, sausage, French toast, and some fresh fruit kabobs. Warm up syrup or melt cheese in the mini pans. You're sure to go back for seconds.

PANCAKES FOR ALL – Everyone's favorite breakfast food. Use the pancake plate side to make up to 8 pancakes at once. Add banana's, chocolate chips, blueberries, or walnuts. Warm up syrup, fresh fruits in the mini pans, and add your favorite toppings to the top of your pile of pancakes! Bet you can't eat just one!

DESSERT BAR – Create a fun party dessert bar. Grill pound cake, or freshly baked muffins. Grill fresh pineapple, peaches, or fresh fruit kabobs. Use the mini pans to warm up syrup, melt chocolate, heat pine nuts, or freshly sliced pears. Kraft your own homemade dessert!

CLEANING AND MAINTENANCE

1. Turn the Temperature Control Dial counterclockwise to the smallest dot position on the left. Remove the plug from the wall outlet.
2. Allow the appliance to cool completely before cleaning.
3. Remove the Reversible Plate, Raclette Pans and Spatulas from the appliance.
4. The Reversible Plate and Mini Pans can be washed in hot soapy water along with the Spatulas. Rinse and Dry. Mini Pans are also dishwasher safe for top rack only.
5. Wipe the Base with a soft damp cloth. Dry.

IMPORTANT NOTES:

- DO NOT WIPE THE ELEMENT
 - DO NOT USE STEEL WOOL OR ABRASIVE CLEANERS ON ANY PART OF THE APPLIANCE.
 - DO NOT IMMERSE THE BASE OR THE PLUG IN WATER OR ANY OTHER LIQUID
6. All servicing, other than cleaning, should be performed by an authorized service representative. See Warranty section.
 7. To protect the appliance's nonstick coating, wipe dry the Reversible Plate and nonstick Mini Pans.

TROUBLESHOOTING

Issue	Cause	Solution
Unit does not turn on	An issue with the power plug.	Check whether the power plug is connected to a functional, grounded electrical outlet. If unit is still not working, please contact Customer Service.
What oils can I use?		Oils with high smoke points, like canola oil and grapeseed oils, are best. If you use Extra Virgin Olive Oil, cook on moderate heat settings to prevent it from burning onto your cooking surface.
Can I use spray oils?		Avoid all oils in spray form as they may damage the nonstick coating of your cooking surface.
I do not know when the grill has reached the selected temperature	Not watching indicator light.	Indicator light illuminates in green and turns off once the grill has reached the selected temperature.
Unsure of how many pancakes the griddle makes		Pancake griddle makes eight pancakes at once.
Unsure of which side of the Grill/Griddle plate to use for certain foods	One side of the Reversible Plate is split in half - half grill, half griddle.	Use the smooth side of the plate for warming, preparing fondue or breakfast foods...etc. Use the ridge side for grilling meats, fish, or vegetables.
Unable to control Lower Plate temperature separately from upper area	Only one temperature control knob.	You cannot control the temperature separately.
Unsure if Mini Pans can be removed during cooking		Yes, the Mini Pans can be moved on and off the Lower Plate as food is cooked and served.
Unsure if can use all Mini Pans at once		Yes, all the Mini Pans can be used at once.
Unsure what to use the spatulas for		Use the spatulas to easily remove food from the Mini Pans.
Trying to cut food directly on the Grill Plate or Mini Pans		Never cut food directly on the Grill Plate or in the Mini Pans.
Unsure of how to turn off unit		Turn the temperature control dial counterclockwise to the smallest dot position on the left. Remove the plug from the wall outlet.
Plate has scratches	Using metal utensils.	DO NOT use metal utensils to place food on or remove food from Plates. Silicone utensils are best and will extend the life of your Plates.
Unit has a slight odor	During first use this may happen.	This is perfectly normal during first use and will disappear with use.
Uncertain about which pieces are dishwasher safe		Only the Mini Pans are dishwasher safe for top rack only. The Reversible Plate or Mini Pans can be washed in hot soapy water along with the spatula.
Unsure of how to clean grill		Wipe the base with a soft damp cloth. DO NOT immerse the base or the plug in water or any other liquid.

LIMITED WARRANTY

GreenPan Electrics are covered by a limited warranty against defects in materials and workmanship, beginning on the date of purchase and lasting for two years. If your GreenPan Electrics product has a defect during the warranty period, The Cookware Company (USA), LLC will either repair or replace the product. Further information on the warranty claim process, exclusions from warranty coverage, and other terms can be found in the complete limited warranty for this product, available online at greenpan.us/warranty.

TERMS OF SALE; ARBITRATION

The terms on which The Cookware Company (USA), LLC sells GreenPan Electrics are available online at greenpan.us/pages/terms-of-sale (the "Terms"). The Terms contain very important information regarding your rights and obligations, as well as conditions, limitations, and exclusions that may apply to you. Please read them carefully.

In particular, the Terms provide that, by your purchase of this product, you and The Cookware Company (USA), LLC are agreeing to give up any rights to litigate in a court or before a jury, or to participate in a class action or representative action with respect to a claim. Other rights that you would have if you went to court may also be unavailable or limited in arbitration. Any claim, dispute, or controversy between you and The Cookware Company (USA), LLC arising from or relating in any way to your purchase of products or services will be resolved exclusively and finally by binding arbitration.

The arbitration will be administered by the American Arbitration Association ("AAA") in accordance with the Consumer Arbitration Rules (the "AAA Rules") then in effect, except as modified hereby. (The AAA Rules are available at adr.org or by calling the AAA at 1-800-778-7879.) The Federal Arbitration Act will govern the interpretation and enforcement of this arbitration and waiver provision. The Cookware Company (USA), LLC will be

responsible for the AAA filing fee of any such proceeding. Other than your right to pursue a claim in small claims court, as described in the Terms, the arbitrator will have exclusive authority to resolve any dispute relating to arbitrability and/or enforceability of this arbitration provision, including any unconscionability challenge or any other challenge that the arbitration provision or these Terms are void, voidable or otherwise invalid. The arbitrator will be empowered to grant whatever relief would be available in court under law or in equity. Any award of the arbitrator(s) will be final and binding on each of the parties and may be entered as a judgment in any court of competent jurisdiction. Attorney fee shifting in this case is governed by the Terms. You agree to an arbitration on an individual basis. In any dispute, NEITHER YOU NOR THE COOKWARE COMPANY (USA), LLC WILL BE ENTITLED TO JOIN OR CONSOLIDATE CLAIMS BY OR AGAINST OTHER CUSTOMERS IN COURT OR IN ARBITRATION OR OTHERWISE PARTICIPATE IN ANY CLAIM AS A CLASS REPRESENTATIVE, CLASS MEMBER OR IN A PRIVATE ATTORNEY GENERAL CAPACITY. The arbitral tribunal may not consolidate more than one person's claims, and may not otherwise preside over any form of a representative or class proceeding. The arbitral tribunal has no power to consider the enforceability of this class arbitration waiver and any challenge to the class arbitration waiver may only be raised in a court of competent jurisdiction. If any provision of the arbitration agreement described herein and in the Terms is found unenforceable, the unenforceable provision will be severed and the remaining arbitration terms will be enforced.



1400026517