

LED UFO High Bay Light

Product Description

Eagle Star LED UFO styled LED High Bay Light Fixtures look like a UFO flying ship, which makes them more futuristic and full of the feeling of high-tech. These LED high bay fixtures come in four models, which can replace 250W to 1000W Metal Halide Lamp. Beam angle is 120°, which is ideal for warehouse, garage, workshop, gymnasium, parking place etc.



- Voltage 100-277V AC 50Hz/60Hz
- Light Efficacy 150lm/w
- Lifespan above 50,000 hours
- Qualified with CE, RoHS, cETL, ETL, DLC
- Sensen LED driver & PHILIPS LEDS
- 5 years warranty
- IP 65
- Die-casted aluminum housing
- High efficiency, energy saving, eco-friendly
- Sealed fixture is dirt and bug free
- PIR and motion sensor available
- Ambient temperature from -40°C to 50°C

Product Parameters

Input Power	100W	150W	200W	240W
LED Chips	PHILIPS LEDS			
Initial Lumens	15,000lm	22,500lm	30,000lm	33,600lm
Efficacy	150lm/w	150lm/w	150lm/w	150lm/w
CRI	> 80Ra			
CCT	3000k/4000k/5000k/5700k			
Beam Angle	120°			
Input Voltage	100-277V AC 50Hz/60Hz			
Working Temperature	-40°C Up to 50°C (-40°F up to 122°F)			
Certification	CE, RoHS, cETL, ETL, DLC premium			
Warranty	5 years			
Replacement	250W MH	480W MH	750W MH	1000W MH
Carton/Pieces	1	1	1	1
G.W	6.40 lbs	8.80 lbs	10.80 lbs	12.8lbs
Carton Size	12.2x12.2 x 8.2 inches	13.4x13.4 x 8.2 inches	15.3x15.3 x 8.2 inches	16.1x 16.1x 8.2 inches

Dimensions

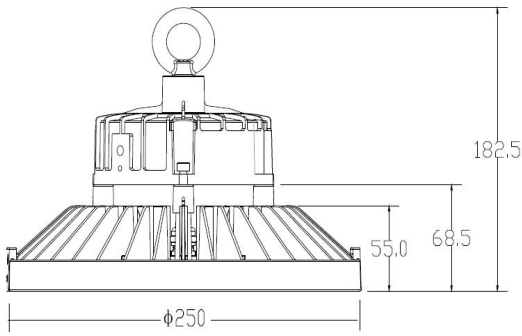

100W

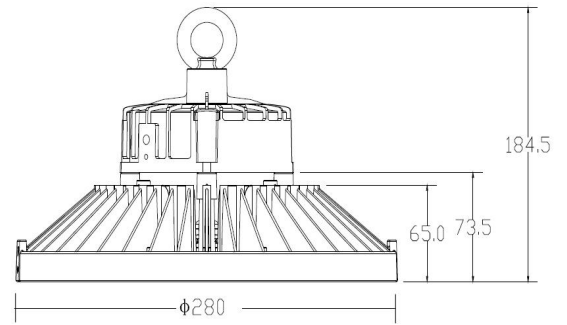

150W

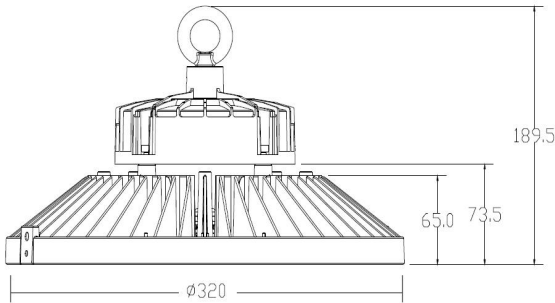

200W

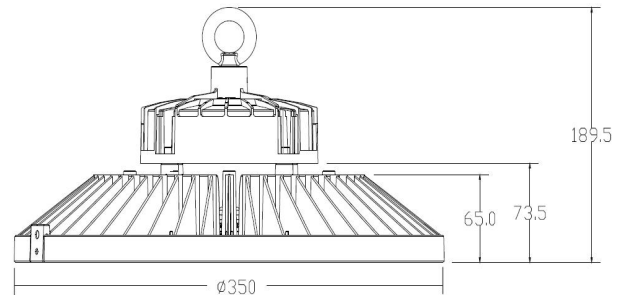

240W

Photometrics

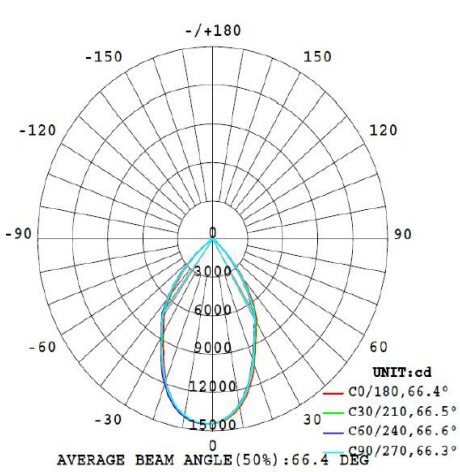

60°

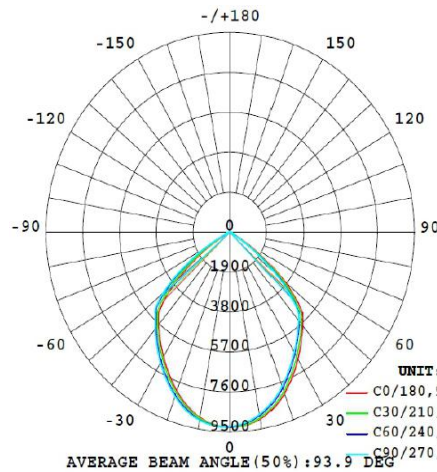

90°

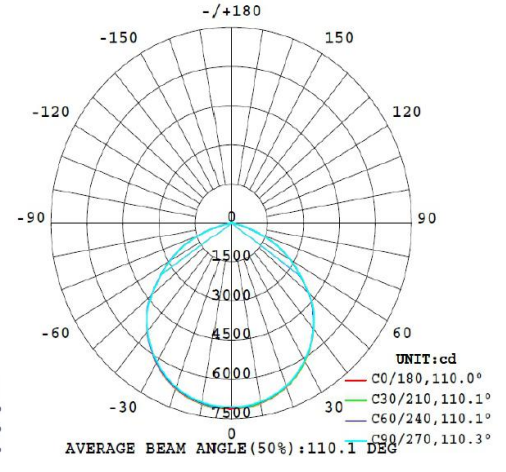

120°

Sonsen LED Driver
0-10V Dimming



Motion sensor



American design, high quality
aluminum die-casting shell
never fade cracking prevention

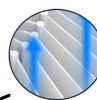

SMD LEDS High efficiency
Brighter luminance
longer lifespan

