

## LED Temporary Work Light

### Product Description

Eagle Star LED Temporary Work Lights have connectors which makes it easier to connect together, and the fixture from 80w to 150w, replace up to 400w metal halide & high pressure sodium, perfect fixture for Chemical plants, chemical warehouses and some workshops that are prone to flammable and explosive dust, gas, etc.



- Voltage 100-277V AC 50Hz/60Hz
- Light Efficacy 130lm/w
- Lifespan above 50,000 hours
- Qualified with CE, RoHS, cETL, ETL, DLC
- UL LED driver & PHILIPS LEDS
- 5 years warranty
- IP 65
- Precision Die Cast Aluminum heat sinks.
- High efficiency, energy saving, eco-friendly
- Sealed fixture is dirt and bug free
- Easy Installation
- Ambient temperature from -40°C to 50°C

### Product Parameters

Input Power	80W	100W	120W	150W
LED Chips	PHILIPS LEDS			
Initial Lumens	10,400lm	13,000lm	15,600lm	19,500lm
Efficacy	130lm/w	130lm/w	130lm/w	130lm/w
CRI	> 80Ra			
CCT	3000k/4000k/5000k/5700k			
Beam Angle	360°			
Input Voltage	100-277V AC 50Hz/60Hz			
Working Temperature	-40°C Up to 50°C (-40°F up to 122°F)			
Certification	CE, RoHS, cETL, ETL, DLC premium			
Warranty	5 years			
Replacement	250W HPS	300W HPS	350W HPS	400W HPS
Carton/Pieces	6	6	6	6
G.W	14.5kg	15.3kg	16.9kg	17.1kg
Carton Size	62*44*42cm	62*44*42cm	62*44*42cm	62*44*42cm

## Dimensions

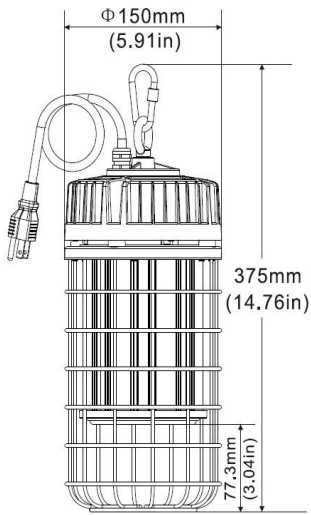

80W

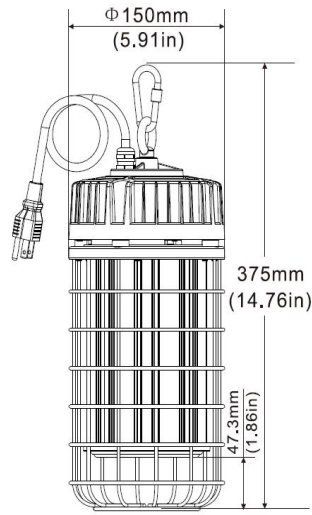

100W

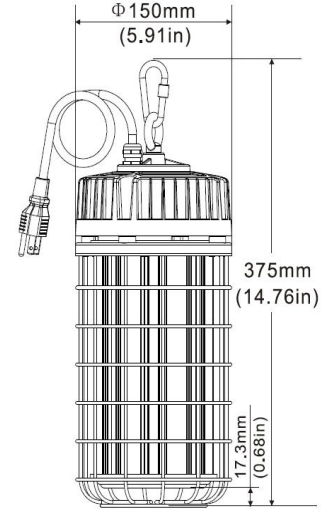

120W&150W

## Photometrics

