

# LED Tri-Proof Light



## Product Description

Eagle Star Lighting LED Tri-proof light operating between 100 and 277 volts, this LED fixture is an energy-efficient, low maintenance alternative to traditional fluorescent in a variety of commercial buildings, also can use as low bay lighting applications at 20 feet or lower. The lights expand the linear product offering to include IP65 rated fixtures for demanding industrial environments.



- Voltage 100-277V AC 50Hz/60Hz
- Light Efficiency 130lm/w
- Lifespan above 50,000 hours
- Qualified with CE, RoHS, cUL, UL, DLC
- UL LED driver & EPISTAR LEDS
- 5 years warranty
- IP 65
- IK09 and 5VA rated shatter-proof optically enhanced diffuser and stainless-steel clips.
- Sealed fixture is dirt and bug free
- Motion sensor compatible
- EMI: Title 47 CFR 15 Class A.
- Ambient temperature from -30°C to 45°C

## Product Parameters

Model NO.	ES-TP040C01-YY
LED Chips	SMD 2835
Input Power	40W
Initial Lumens	5,200lm
Efficacy	130lm/W
CRI	> 80Ra
CCT	3000k/4000k/5000k/5700k
Input Voltage	100-277V AC 50Hz/60Hz
Working Temperature	-30°C Up to 45°C (-22°F up to 113°F)
Certification	CE, RoHS, cUL, UL, DLC
Warranty	5 years
Carton/Pieces	6
G.W	8.7kg
Carton Size	130*16*21cm

## Dimensions

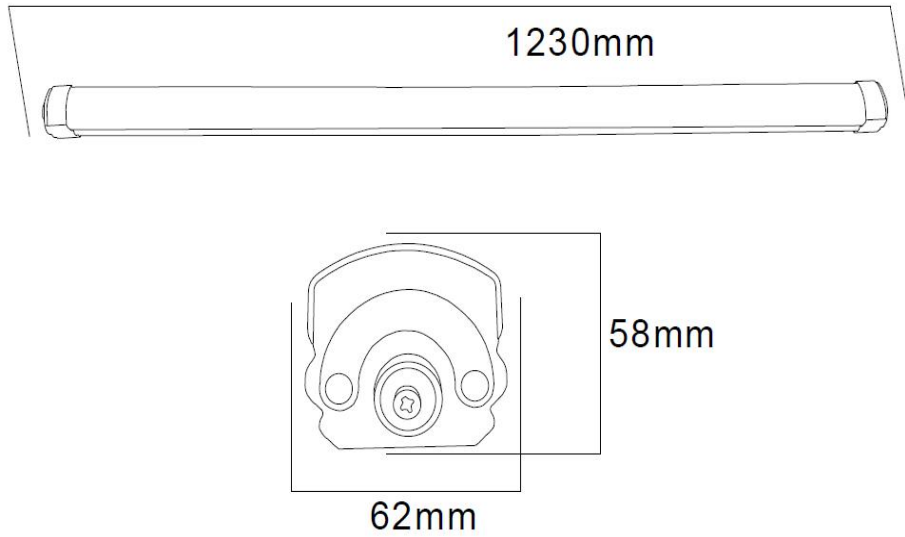

## Photometrics

