

## LED Post Top Light

### Product Description

Eagle Star LED Post Top Lamps are a convenient and energy-efficient solution for replacing traditional high-pressure sodium and metal halide sources in enclosed lighting fixtures, which is a term to describe the outdoor lighting that is commonly mounted on poles and located in roadways, pathways, parking lots and commercial and educational campuses.



- Voltage 100-277V AC 50/60Hz
- PHILIPS LEDS with efficiency 130lm/w
- Lifespan above 50,000 hours
- Qualified with CE, RoHS, cETL, ETL
- 5 years warranty
- IP 66
- UL LED driver PF > 0.95, THD < 10%
- Finish color is black .
- Optics are interchangeable and easily replaceable
- Dusk to dawn sensor compatible
- Ambient temperature from -40°C to 40°C

### Product Parameters

Model NO.	ES-PT040B01-YY	ES-PT060B01-YY	ES-PT100B01-YY	ES-PT150B01-YY
LED Chips	PHILIPS LEDS			
Input Power	40W	60W	100W	150W
Initial Lumens	5,200lm	7,800lm	13,000lm	19,500lm
Efficacy	130lm/w	130lm/w	130lm/w	130lm/w
CRI	> 75Ra			
CCT	3000k/4000k/5000k/5700k			
Input Voltage	100-277V AC 50/60Hz			
Working Temperature	-40°C Up to 40°C (-40°F up to 104°F)			
Certification	CE, RoHS, cETL, ETL			
Warranty	5 years			
Replacement	100W	150W MH	300W MH	600W MH
Carton/Pieces	1	1	1	1
G.W	7.5kg	7.6kg	7.8kg	7.8kg
Carton Size	52*52*22cm	52*52*22cm	52*52*22cm	52*52*22cm

## Dimensions

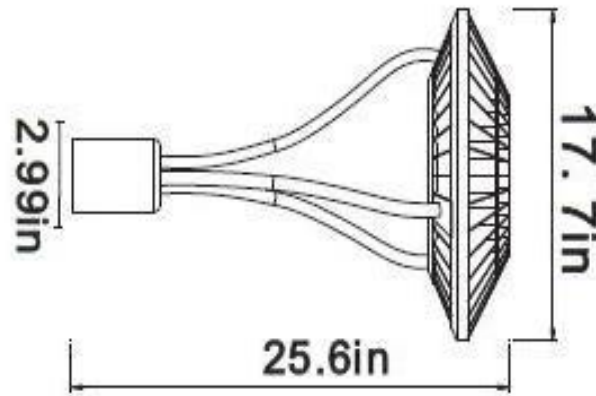

## Photometrics

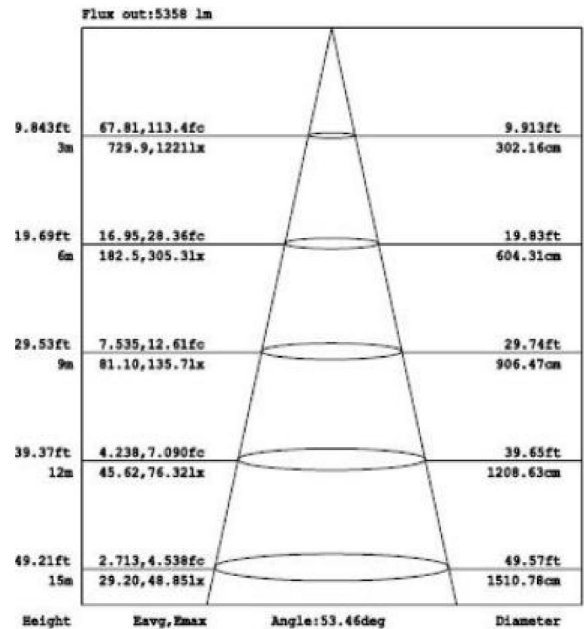
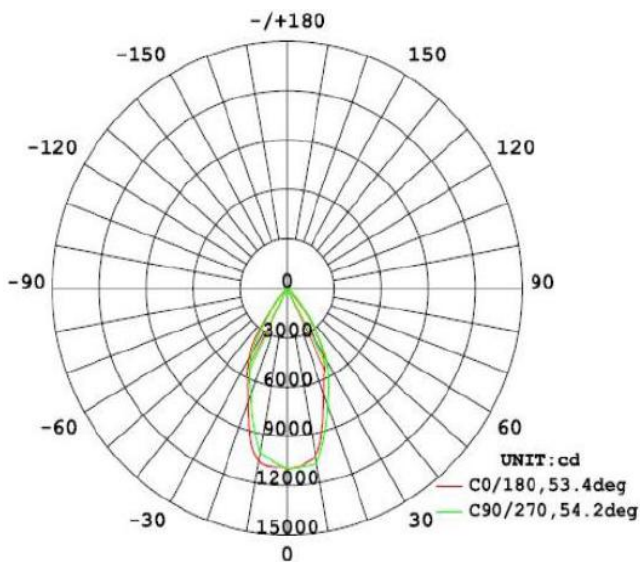



**UL approved  
LED Driver**



**PHILIPS LEDS  
High lumenous  
Long lifespan**



**Detachable lamp pole  
Easy for installation  
and shipment**

**Inner diameter is 3 inch,  
which can meet 2-3/8"  
and 3" poles**