

INSTALLATION INSTRUCTIONS ALTITUDE KIT



THIS DOCUMENTATION APPLIES TO:

AIR PRESSURE SENSOR FOR HEATING MODE AT ALTITUDES,
IN CONJUNCTION WITH THE EASYSTART CONTROL UNIT

- TIMER
- REMOTE
- REMOTE+
- SELECT

CONTENTS

CHAPTER	DESCRIPTION	CHAPTER CONTENT	PAGE
1	INTRODUCTION		
		Please read first	3
		General information / safety instructions	3
		Scope of supply	3
		Purpose	3
		Compatibility	3
		Technical data	3
2	FUNCTIONAL DESCRIPTION		
		Functional description	4
3	INSTALLATION		
		Installation location	4
		Electrical connection	4
4	FUNCTIONAL CHECK		
		Functional check	5
5	DIAGNOSTICS		
		Diagnostics	6
6	WHAT TO DO IF ...		
		Malfunction – heater	7
		Malfunction – during the functional test	7
7	ELECTRICS		
		Parts list, circuit diagrams	7
		Circuit diagram: connecting the air pressure sensor to Hydronic water heaters	8
		Circuit diagram: connecting the air pressure sensor to Airtronic air heaters	9
		Circuit diagram: connecting the air pressure sensor via On signal S+(YE) to Hydronic water heaters	10
		Circuit diagram: connecting 2× air pressure sensors to 2 heaters with one control unit	11
		Circuit diagram: connecting 2× air pressure sensors to 2 heaters with one control unit each	12

1 INTRODUCTION



PLEASE READ FIRST

Before you start to install the air pressure sensor, always read through these installation instructions carefully.

These installation instructions contain important information, which you need to install the air pressure sensor.

GENERAL INFORMATION / SAFETY INSTRUCTIONS

Always note and follow all information and notes, especially the safety instructions in these installation instructions and in the heater's technical description!

SCOPE OF SUPPLY

Order no. 22 1000 33 22 00

Quantity Designation

1	Air pressure sensor
2	Self-tapping screws, B 3.9 x 19 for fixing the air pressure sensor
1	Bush housing, 4 pin
1	Cover cap with lever for bush housing, 12 pin
1	Adapter cable
1	Installation instructions
1	Fuse, bush housing
4	Bushing contacts (use if necessary)

PURPOSE

The air pressure sensor, together with the control box of the heater, is used to control heating mode at altitude (vehicle class M, N and O).

COMPATIBILITY

Before installing the altitude kit, check the compatibility of the heater, air pressure sensor and control unit in the Service Portal and / or by phoning the Hotline.

SERVICE PORTAL

- <https://partner.eberspaecher.com>

HOTLINE WITHIN GERMANY

- Tel. 03976 2350235
- Fax 01805 262624

Outside of Germany, please contact the respective Eberspächer national representative (<http://www.eberspaecher.com/en/worldwide.html>).

TECHNICAL DATA

Max. allowable altitude:	approx 4000 m
Measurement range:	600 hPa to 1150 hPa
Rated voltage:	12 volt / 24 volt
Operating voltage:	8 Volt to 32 Volt
Dimensions:	76 x 76 x 29 mm
Operating temperature:	-40 °C to +85 °C



IMPORTANT!

Safety instructions for technical data!

Failure to comply with the technical data can result in malfunctions.



NOTE

Provided no limit values are given, the technical data provided is with the usual tolerances of $\pm 10\%$ at rated voltage, 20 °C ambient temperature and reference altitude Esslingen.

2 FUNCTIONAL DESCRIPTION 3 INSTALLATION

FUNCTIONAL DESCRIPTION

After starting the heater the air pressure sensor measures the atmospheric air pressure cyclically and transmits the measured values to the heater's control box. The control box evaluates the measured values and if necessary adjusts the fuel delivery rate of the metering pump to the current atmospheric air pressure. A reduction in the delivery rate begins from approx. 1400 m, this causes a simultaneous reduction in the heating capacity of approx. 9 % per 1000 metres of altitude.

NOTE

In addition, the heaters' control behaviour can change, i.e. the control stages in the technical data (see technical description of the heater) are no longer adhered to.

INSTALLATION LOCATION

If possible, position the air pressure sensor in a clean and dry place in the vehicle's interior with the plug-in connector facing downwards.

NOTE

- The installation location of the air pressure sensor must not be near ventilation outlets or directly near the fan motor.
- The installation space must not be airtight.
- The air pressure sensor may not be installed in an airtight packaging

ELECTRICAL CONNECTION

CONNECT ADAPTER CABLE

Push the 12-pin bush housing (4) of the adapter cable (3) into the cover cap (5), until it latches into position. Push in the 12-pin connector [cover cap (5) and bush housing (4)] at the air pressure sensor (1), until the lever locks automatically.

Connect the 4-pin bush housing (7) to the lead harness (8) and secure with the fuse (11). Then make the connection with the 4-pin bush housing (6) from the adapter cable (3).

Connect the bush housing (9) included with the control unit to the adapter cable and connect to the control unit cable loom (10).

NOTE

- Refer to the end of these instructions for the circuit diagrams.
- Insulate and tie back unused cables of the lead harness(8).

3 INSTALLATION

4 FUNCTIONAL CHECK

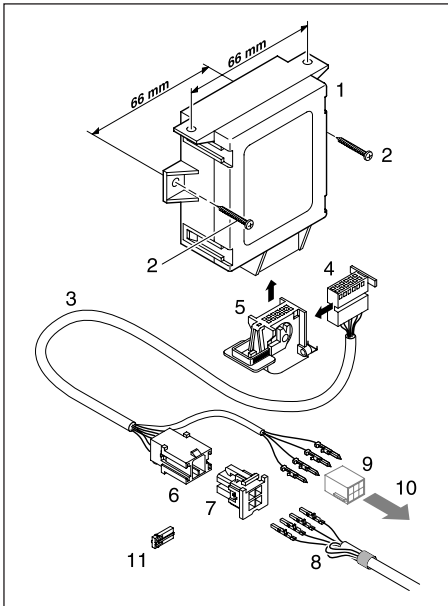

- 1 Air pressure sensor
- 2 Self-tapping screws B 3.9 x 19
- 3 Adapter cable
- 4 Bush housing, 12 pin
- 5 Cover cap with lever, for bush housing, 12-pin (Item 4)
- 6 Bush housing, 4-pin (tab connector)
- 7 Bush housing, 4-pin (push-on sleeves)
- 8 Lead harness from the heater to the adapter cable
- 9 Bush housing, included with the control unit
- 10 Connect Item 9 to the control unit
- 11 Fuse, bush housing

i NOTE (ITEM 8)

Use contacts from the scope of supply if no contacts or unsuitable contacts are installed on lead harness (Item 8).

FUNCTIONAL CHECK

Switch on the heater with connected air pressure sensor at the control unit.

If the metering pump starts to pump fuel, switch the heater back off again.

If the heater's afterrun has ended, connect the ISO adapter with the required adapter cable (Order No.: 22 1000 33 31 00) to the air pressure sensor.

In the EDiTH – customer service program, Version S3V7-F and higher – select the connected heater type and read out the “lowest atmospheric air pressure” via General Data + Fault Memory.

If “lowest atmospheric air pressure” >0 hPa is displayed, the air pressure sensor is connected correctly and is functioning.

5 DIAGNOSTICS

DIAGNOSTICS

The air pressure sensor connected to the heater can be diagnosed. If errors occur during the altitude adjustment they are saved in the air pressure sensor and can be read out if necessary using the ISO adapter in conjunction with the EDiTH customer service program – Version S3V7-F and higher. The adapter cable (Order No.: 22 1000 33 31 00) is also required.

PERFORM DIAGNOSIS OF THE AIR PRESSURE SENSOR

Disconnect the air pressure sensor / heater cable loom interface, connect the ISO adapter with the additionally required adapter cable and start the diagnosis of the air pressure sensor.

The following actions are possible:

- Read out the current fault and the fault memory.
- Delete the fault memory.
- Query the current measured air pressure.
- Query the operating state.
- Query the general data.

NOTE

The fault memory of the air pressure sensor can only be read out with the EDiTH customer service program – Version S3V7-F and higher.

The heater diagnosis can be performed even if the air pressure sensor is connected

- with the EasyStart Remote+, EasyStart Timer control units
- with the diagnostic unit, (connection at "Heater connection plug / cable harness" interface with appropriate adapter cable).

Fault code display	Fault description	Comments → Remedial action
0	No fault	—
11	Communication loss on the diagnostics cable between the HCTRL and air pressure sensor	Cable interruption on the diagnostics cable between the HCTRL and air pressure sensor → Check the wiring and plug-in connections
12	HCTRL does not support altitude mode with the air pressure sensor	Air pressure sensor has been connected to a heater that does not support altitude adjustment → Use a heater that supports altitude adjustment
13	Air pressure sensor fault	The air pressure sensor is defective → Replacing the air pressure sensor

6 WHAT TO DO IF ...

MALFUNCTION – HEATER

- Altitude adjustment not possible.
 - Heater control box is not suitable for altitude adjustment.
 - Check the wiring.
 - Air pressure sensor outside the specified measuring range.
 - Air pressure sensor is defective → replace the air pressure sensor.
- Heater switches off again immediately or cannot be started.
 - Read out the fault memory of the heater control box and the air pressure sensor, correct errors if necessary.
 - In the case of air heaters in vehicles, which are used for transporting dangerous goods (ADR), the WHRD cable is not connected to the control unit.

MALFUNCTION – DURING THE FUNCTIONAL TEST

- If, during the functional test with the EDiTH customer service program, the lowest atmospheric air pressure displayed = 0 hPa
 - Check the wiring and plug-in connections.
- The “lowest atmospheric air pressure” display is not displayed in the general data
 - Heater does not support the height adjustment.

7 ELECTRICS

PARTS LIST, CIRCUIT DIAGRAMS

-E50	Air pressure sensor
c	to the heater
c1	to heater 1
c2	to heater 2
g	to the heater
m	to the control unit
m1	to control unit 1
m2	to control unit 2
x	Insulate cable and tie back
y	Connect cables and insulate
*	Bush contact is in use; use the bush housing of the respective control unit.
**	Bush contact is in use; cable of EasyStart SELECT must be tied back and insulated; use bush housing of respective control unit.
***	Connection, heater 1
****	Connection, heater 2



NOTE

The air pressure sensor (-E50) **cannot** be used with the Airtronic B4 heater.

CABLE COLOURS

RD	red	GR	grey	BK	black
BU	blue	YE	yellow	GN	green
WH	white	VT	violet		
OR	orange	BN	brown		

7 ELECTRICS

CIRCUIT DIAGRAM: CONNECTING THE AIR PRESSURE SENSOR TO HYDRONIC WATER HEATERS HYDRONIC / HYDRONIC II / HYDRONIC II COMFORT

X:150
Ign (+)

X:580
Light (+)

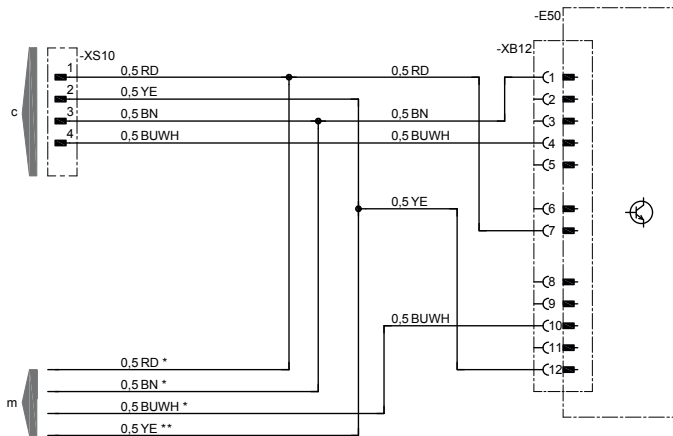

22 1000 34 97 75

7 ELECTRICS

CIRCUIT DIAGRAM: CONNECTING THE AIR PRESSURE SENSOR TO AIRTRONIC AIR HEATERS AIRTRONIC / AIRTRONIC M / AIRTRONIC L

X:15 Ign (+)
X:58 Light (+)

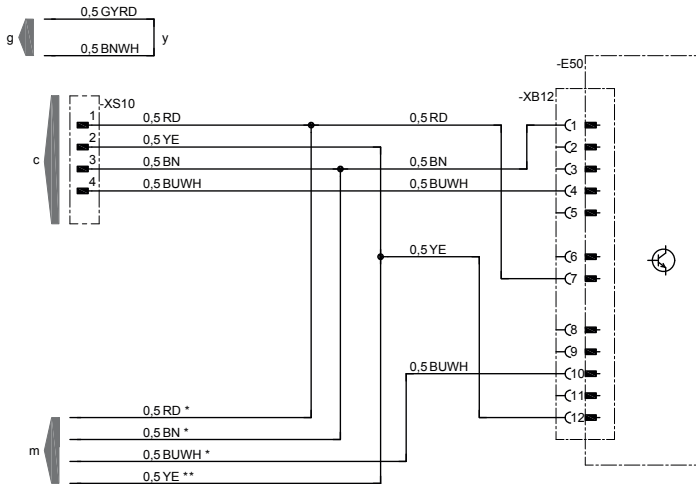

22 1000 34 97 76

7 ELECTRICS

CIRCUIT DIAGRAM: CONNECTING THE AIR PRESSURE SENSOR VIA ON SIGNAL S+(YE) TO HYDRONIC WATER HEATERS

HYDRONIC / HYDRONIC II / HYDRONIC II COMFORT

X:150
Ign (+)
X:580
Light (+)

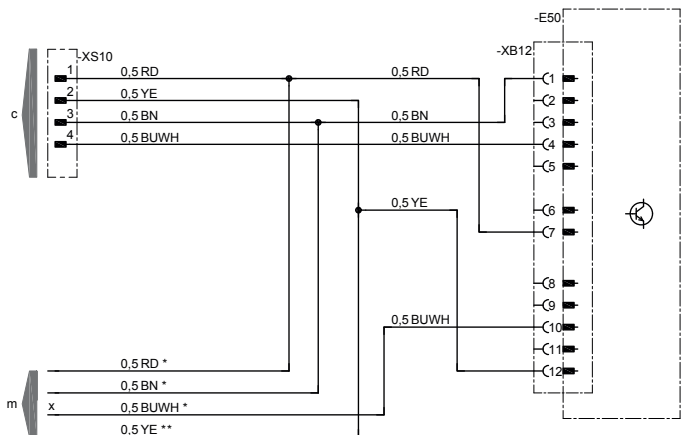

22 1000 34 97 77

7 ELECTRICS

CIRCUIT DIAGRAM: CONNECTING 2× AIR PRESSURE SENSORS TO 2 HEATERS WITH ONE CONTROL UNIT 2× HYDRONIC WATER HEATERS / 2× AIRTRONIC AIR HEATERS / HYDRONIC – AIRTRONIC COMBINATION

X:150
Ign (+)
X:580
Light (+)

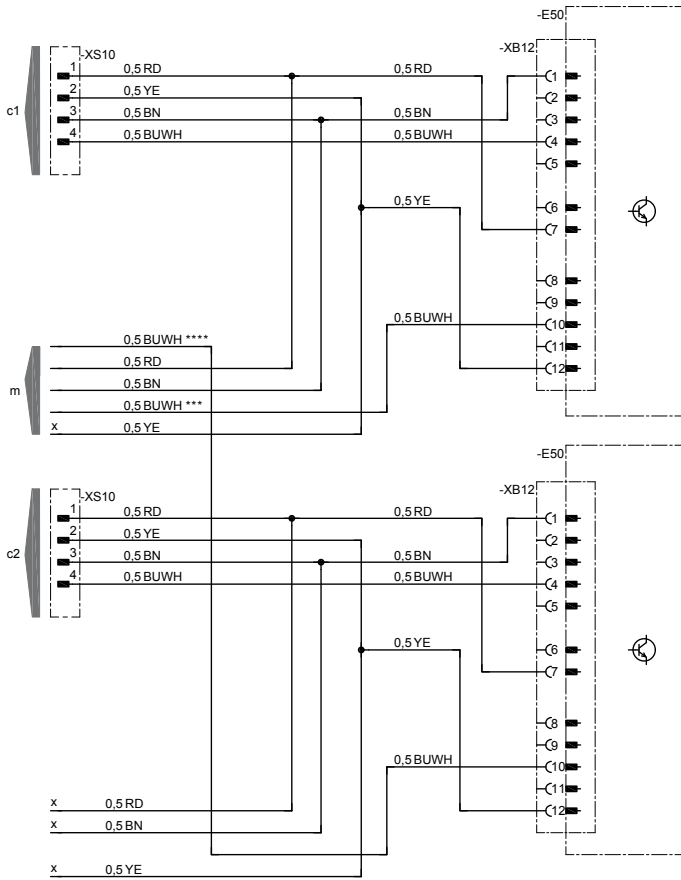

22 1000 34 97 78

7 ELECTRICS

CIRCUIT DIAGRAM: CONNECTING 2x AIR PRESSURE SENSORS TO 2 HEATERS WITH ONE CONTROL UNIT EACH 2x HYDRONIC WATER HEATERS / 2x AIRTRONIC AIR HEATERS / HYDRONIC – AIRTRONIC COMBINATION

X:150
 Ign (+)
 X:580
 Light (+)

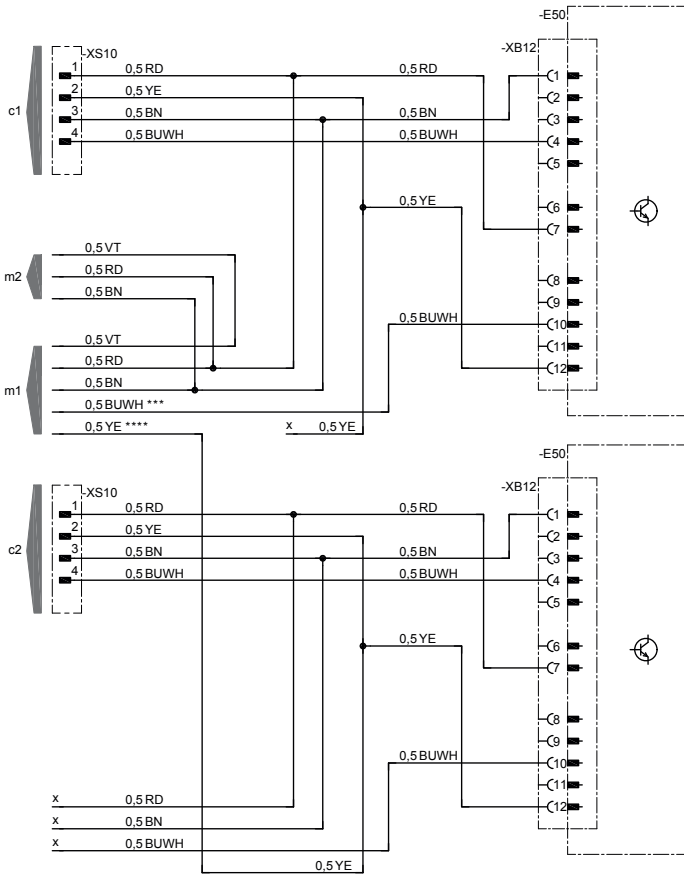

22 1000 34 97 79

Headquarters:

Eberspächer Climate Control Systems

GmbH & Co. KG

Eberspächerstraße 24

73730 Esslingen

Hotline: 03976 2350235

Fax hotline: 01805 262624

info@eberspaecher.com

www.eberspaecher.com



Eberspächer