

Wiring Diagram

MCS-5
 Rixens Enterprises Inc.
 4 Switch Remote
 with S3 furnace
 © 2020 v6.1c

WiFi Diagnostic

4 Switch Remote

1. Ground
2. Power 12VDC fused 10A
3. Furnace Start
4. bridged to #5
5. bridged to #4
6. Water Pump +
7. Fans +
8. n/a
9. T-Stat return (yellow wire)
10. T-Stat Power (red wire) and WiFi Code Reader Power

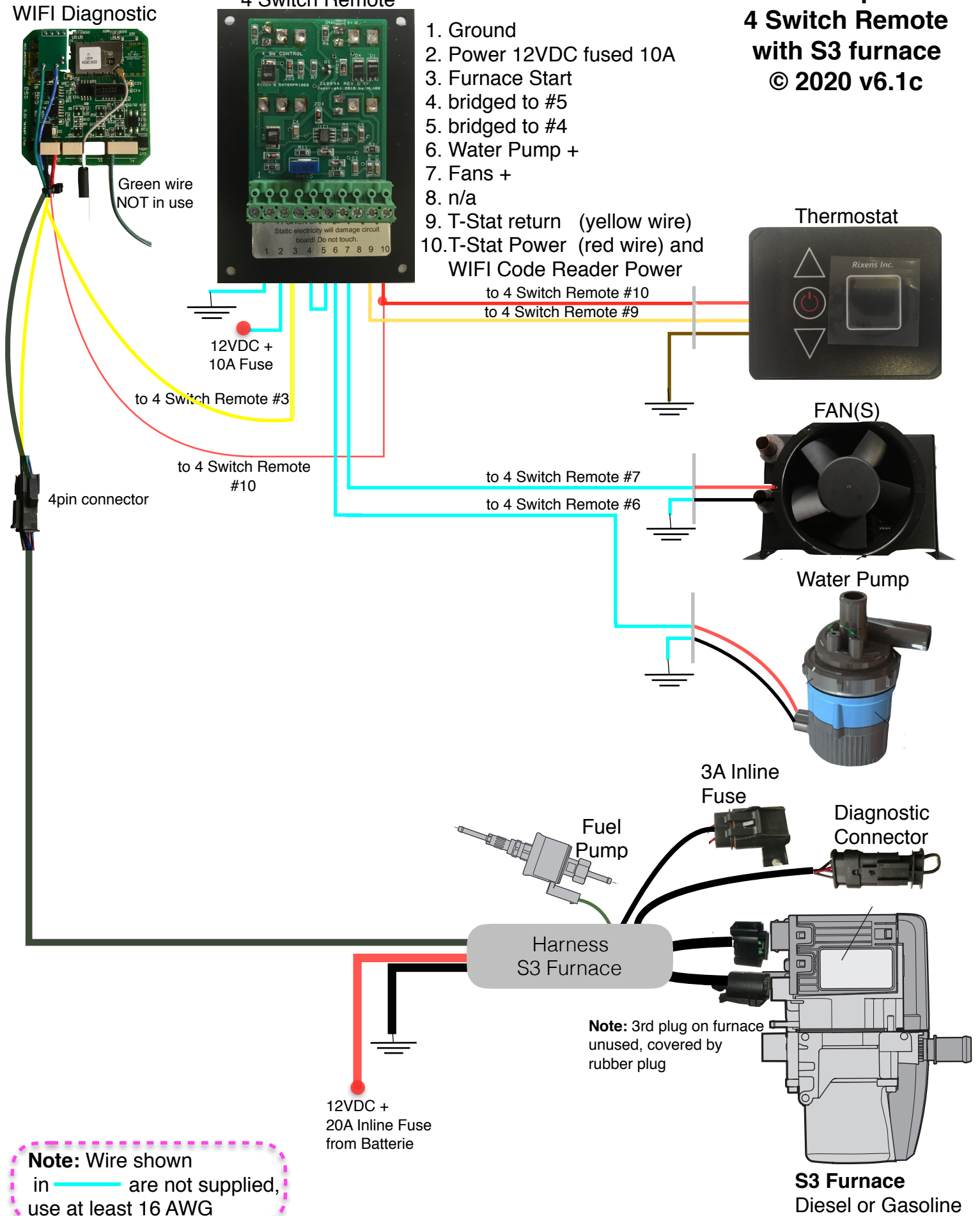

Note: Wire shown in — are not supplied, use at least 16 AWG

12VDC + 20A Inline Fuse from Batterie

Note: 3rd plug on furnace unused, covered by rubber plug

S3 Furnace
 Diesel or Gasoline