

Concrete Anchor

NEW

Provides user
with a
permanent
concrete
anchor point



Product News

AJ720A - Concrete Anchor

- Ideal anchor for permanently installed applications onto concrete surfaces
- Mounts horizontally or vertically
- Includes forged D Ring and concrete anchorage bolts
- Compact and lightweight unit
- Quick and easy to install
- Powder coated red for durability and visibility
- Meets or exceeds all applicable industry standards



Call 1800 245 002 (AUS) 0800 212 505 (NZ)

Head Office and Manufacturing
20 Fariola Street Silverwater NSW 2128 Australia
Phone: +61 2 9748 0335 Fax: +61 2 9748 0336
Email: sales@capitalsafety.com.au www.sala.com.au
A Division of the Capital Safety Group (Australia) Pty Ltd



Concrete Anchor

The AJ720A Protecta Concrete Anchor is designed to be used as a permanently installed anchorage connector on concrete surfaces.

The kit consists of a steel anchorage plate with integral forged D ring and four concrete bolts. In use, the anchorage plate is mounted to either a vertical or horizontal concrete surface and secured via the bolts included in the kit. (See Instruction sheet)

Typical Applications include the connection of shock absorbing lanyards, self retracting lifelines, temporary horizontal lifelines, and rope grab systems to concrete structures such as roofs and parapet walls.

The AJ720A Concrete Anchor can also be adapted to suit steel structures. (Bolts not supplied)

The Concrete Anchor is part of the PROTECTA anchorage range. Protecta anchorage devices are designed to be adaptable to virtually any circumstance where connection of a fall protection system to a suitable anchorage point is necessary.

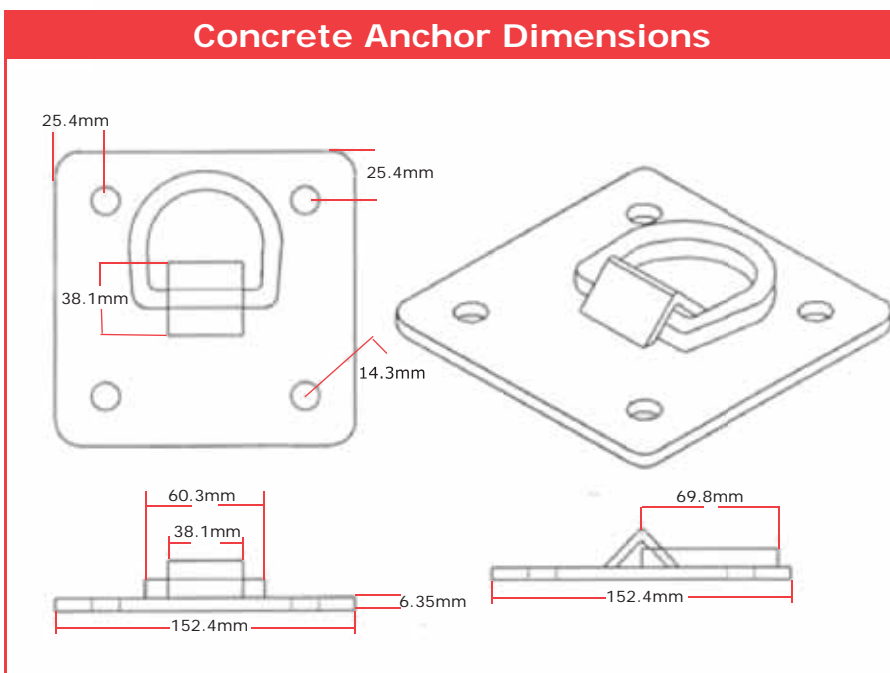

Other Anchorage Devices:

AM450/120AU - 1.2m webbing round strap	AM201 - Manuclave mobile anchorage point
AM450/150AU - 1.5m webbing round strap	AM210 - Fixed anchoring plate
AM500/100AU - 1.0m anchor strap with interlocking rings	AM211 - Fixed anchor D ring
AM500/150AU - 1.5m anchor strap with interlocking rings	AJ703A - Rail Dog® Rail Anchor

Specifications: Concrete Anchor

Part Number	AJ720A
Size	As per drawings above
Hardware	D Ring (fall arrest rated) - Forged, Zinc plated stamped steel
	Plate - 6.35mm steel plate
	Bolts - 4 wedge style concrete insert anchorage bolts
Minimum Breaking Strength	22kN
Weight	1.8kg
Capacity	141kg (Combined weight of person, tools, clothing etc.)
Compatibility	Protecta Concrete Anchor is designed for use with Protecta approved components and systems
Rating	Rated for single person use
Standards	OSHA 1926, ANSI Z359.1-1998, AS/NZS 1891.4
Country of Origin	United States of America

Special Instructions / Conditions of Use

Reading installation instructions prior to use is essential

ISO 9001 - With a full quality assurance program certified under ISO 9001, PROTECTA supplies the industry with a quality range of safety products to provide added security. That's why we back each of our fall protection and rescue systems with the best training, technical assistance and customer service in the business. It makes life easier for you and safer for your workers.



Call 1800 245 002 (AUS) 0800 212 505 (NZ)

Head Office and Manufacturing
20 Fariola Street Silverwater NSW 2128 Australia
Phone: +61 2 9748 0335 Fax: +61 2 9748 0336
Email: sales@capitalsafety.com.au www.sala.com.au
A Division of the Capital Safety Group (Australia) Pty Ltd

