

NORTH™ EXPLORER LOW

ASSEMBLY MANUAL / MONTAGEANLEITUNG

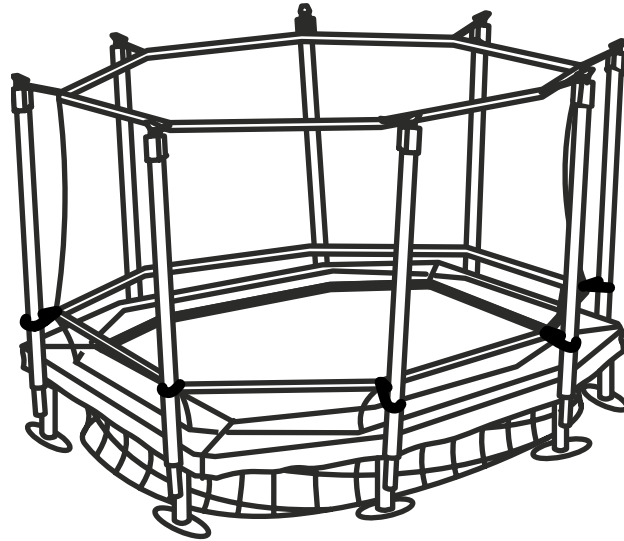

ROUND

430

360

300



OVAL

500

420

350



RECTANGULAR

460

All rights reserved 2021. Avero AB ©

All artwork and illustrations are owned by Avero AB, Sweden.

Copying or reusing them is prohibited by law.

For more information, contact us at info@northtrampoline.com

Alle Rechte vorbehalten 2021. Avero AB ©

Alle Grafiken und Illustrationen sind im Besitz von Avero AB, Schweden.

Deren Kopieren oder Weiterverwendung ist gesetzlich verboten.

Kontaktieren Sie uns unter info@northtrampoline.com

um weitere Informationen zu erhalten.

**ENG: WARNING!**

This trampoline requires a hole to be dug BEFORE it can be used. Jumping before digging a correct hole can cause serious injury. Check that the hole is intact frequently to avoid possible injury.

SV: VARNING!

Du måste gräva ett hål INNAN du använder den här studs mattan. Hoppning innan det finns ett ordentligt hål kan leda till allvarliga skador. Kontrollera regelbundet att hålet är intakt för att undvika skador.

NO: ADVARSEL!

Denne trampolinen krever at det graves et hull FØR trampolinen kan tas i bruk. Følg anvisningene for hvordan hullet skal graves og kontroller at hullet er intakt og i orden i henhold til manualen før bruk for å unngå eventuelle skader.

DK: ADVARSEL!

Denne trampolin kræver, at der graves et hul, FØR den kan anvendes. At hoppe, før der er gravet et korrekt hul, kan medføre alvorlig skade. Kontroller hyppigt, at hullet er intakt for at undgå eventuel skade.

DE: WARNUNG!

Dieses Trampolin erfordert, dass eine Vertiefung/Erdaushub gegraben wird, bevor es benutzt werden kann. Wird gesprungen, ohne dass zuvor eine ordnungsgemäße Vertiefung hergestellt worden ist, besteht die Gefahr schwerer Verletzungen. Überprüfen Sie häufig, ob die Vertiefung intakt ist, um möglichen Verletzungen vorzubeugen.

FI: VAROITUS!

Tälle trampoliinille on kaivettava kuoppa ENNEN kuin sitä voi käyttää. Matolla hyppiminen ennen oikeanlaisen kuopan kaivamista voi aiheuttaa vakavia loukkaantumisia. Tarkasta, että kuoppa on kunnossa, mahdollisten loukkaantumisten välttämiseksi.

EXPLORER LOW

300, 360, 430

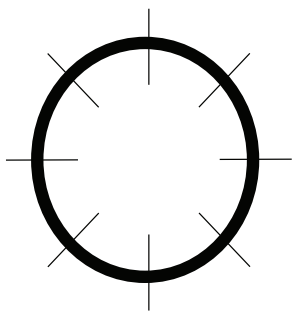

8x

8x

1x

1x

0-8x

1x

1x

8x

300 64x

360 80x

430 96x

16x

42x

EXPLORER LOW

350, 420, 500

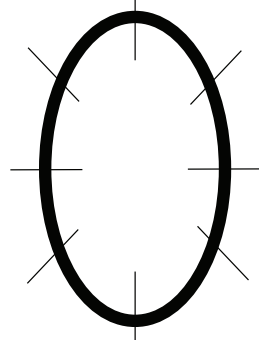

4x

4x

8x

1x

1x

0-8x

1x

1x

8x

350 64x

420 80x

500 96x

16x

42x

EXPLORER LOW

460

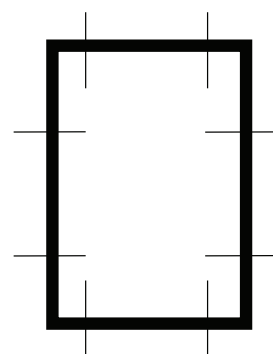

2x

2x

4x

8x

1x

1x

0-10x

1x



1x

8x

460 100x

24x

42x

1  

8x

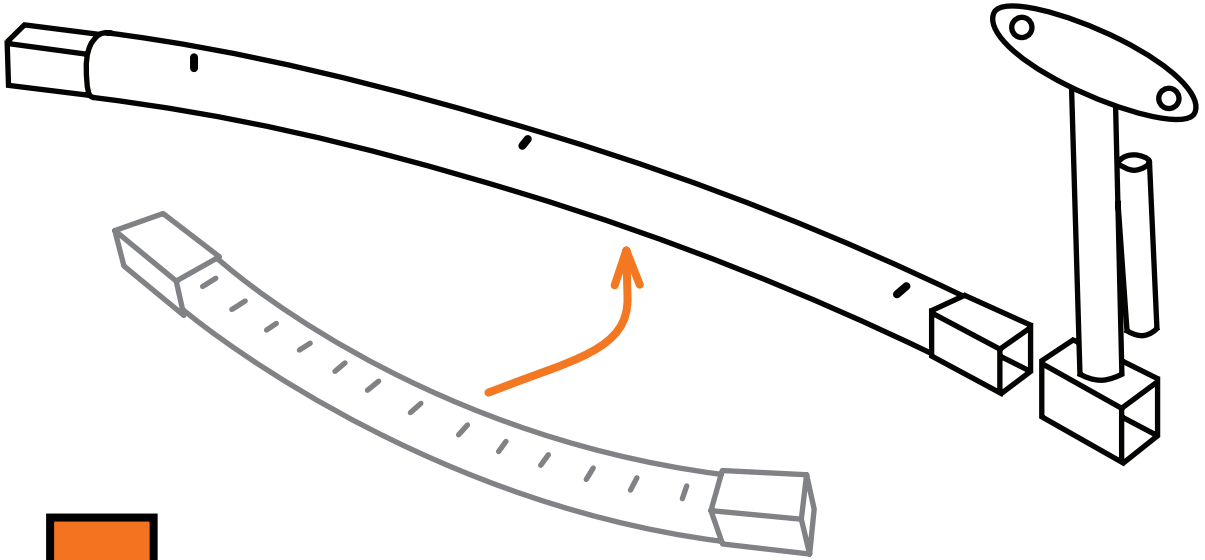

1 

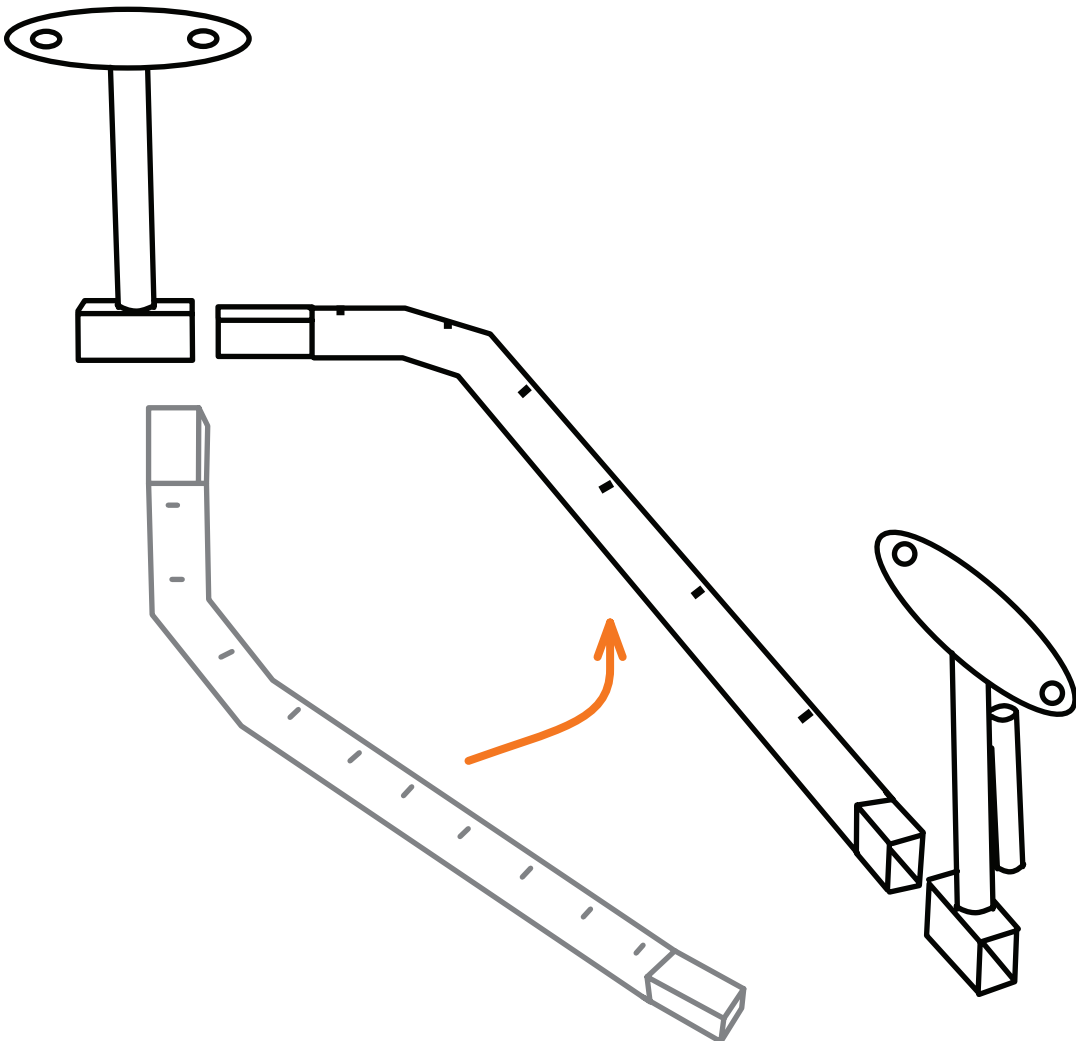

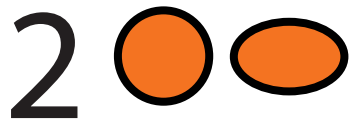

4x

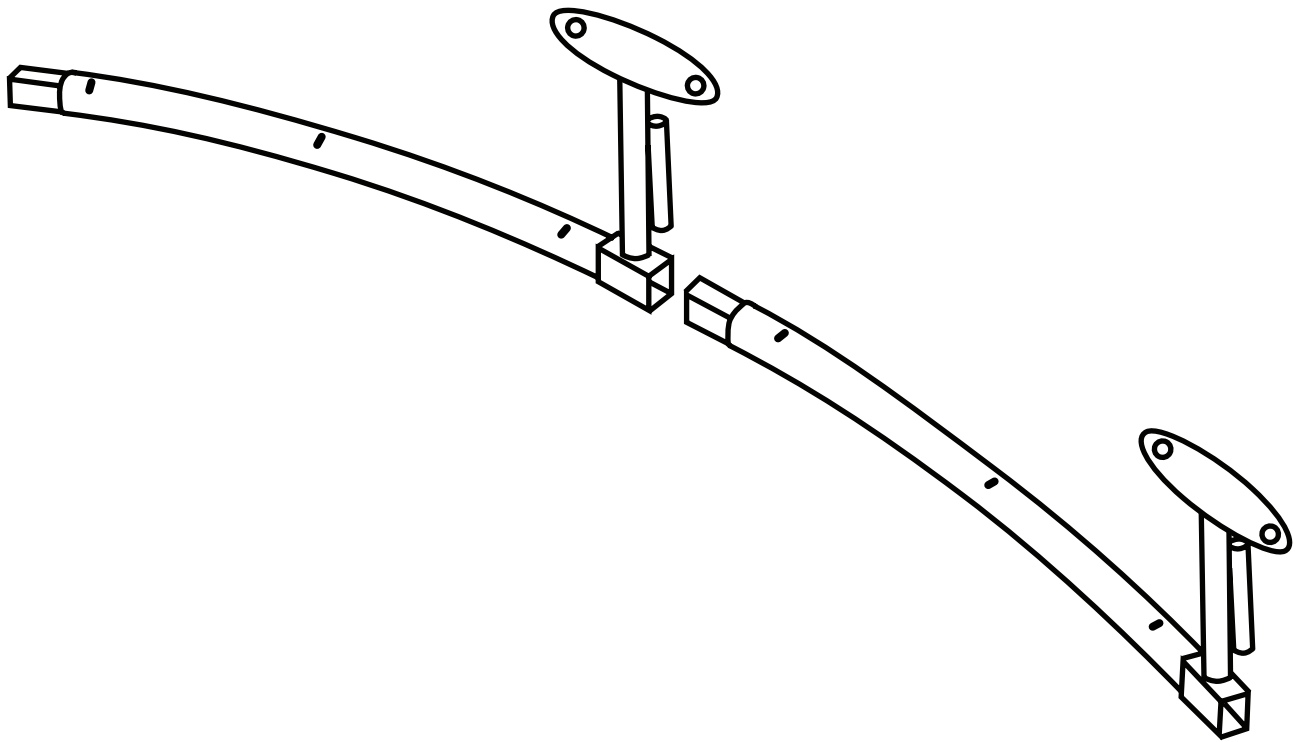
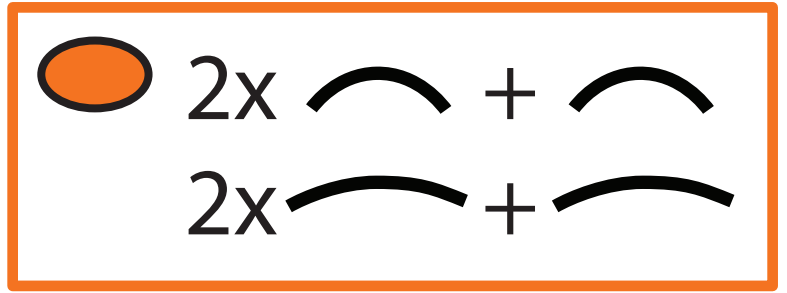

3 ● ●

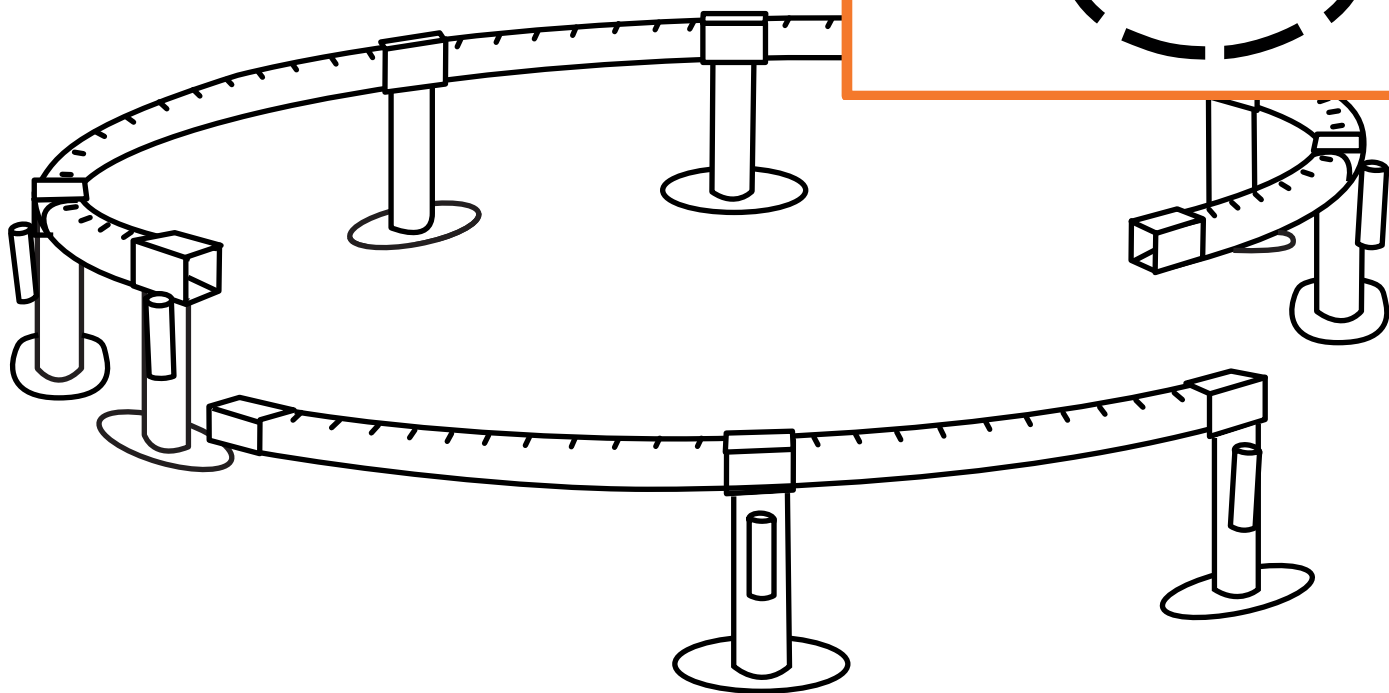
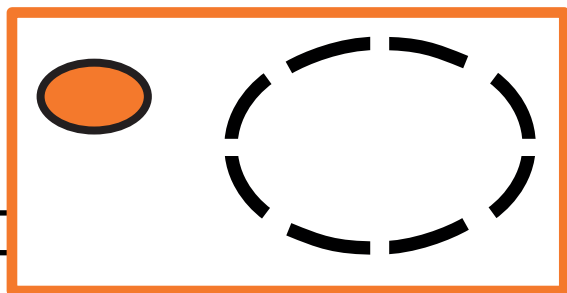

3 ■

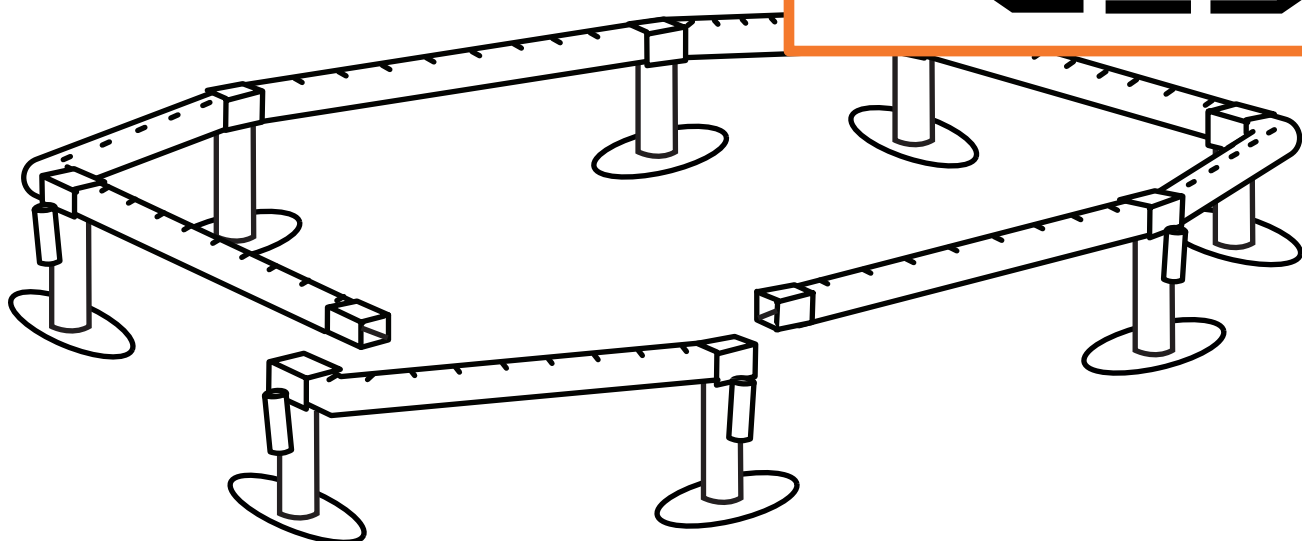
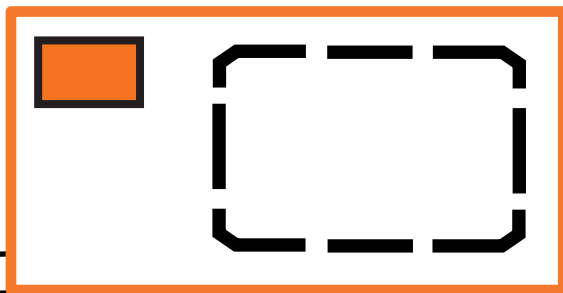

4 ○ ○ □

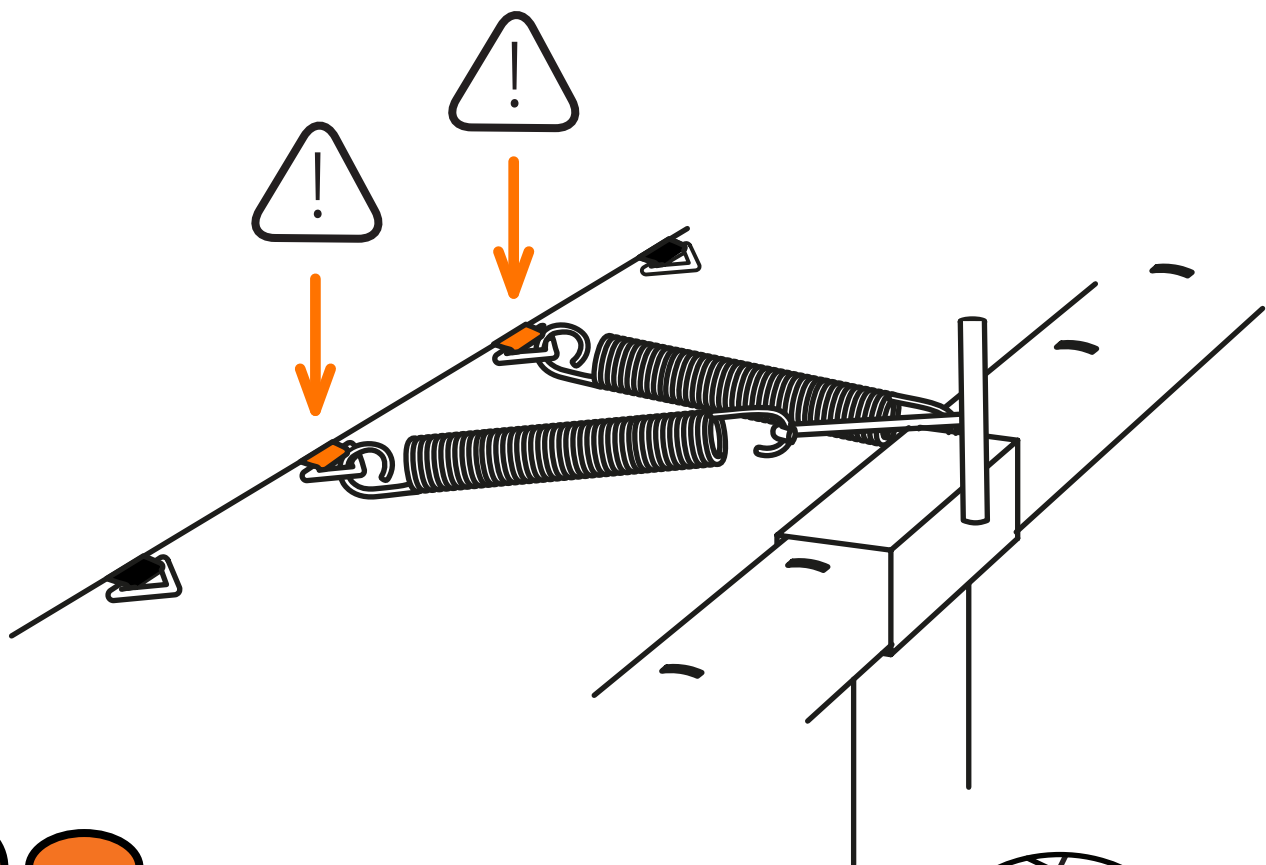

○ ○

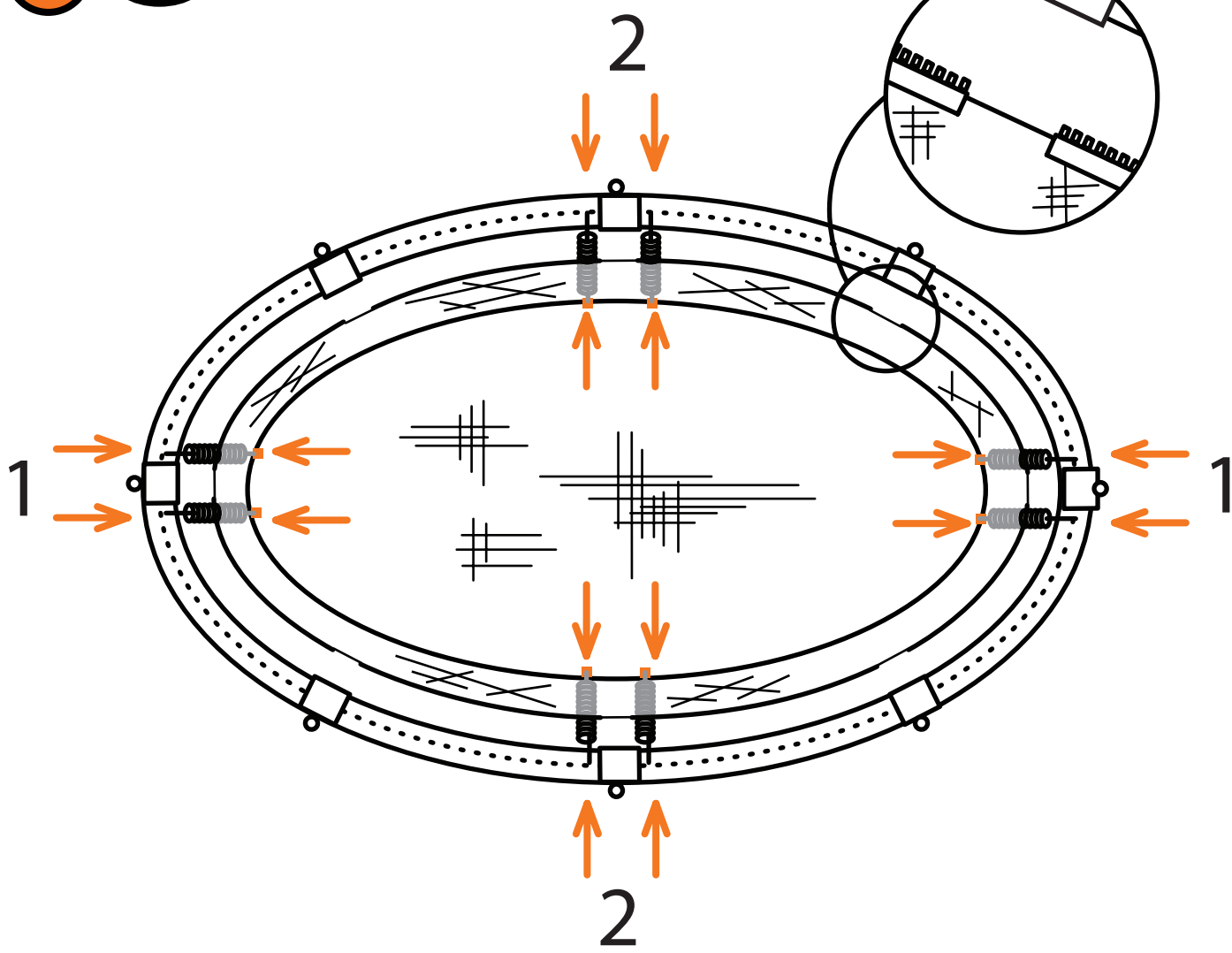

4 

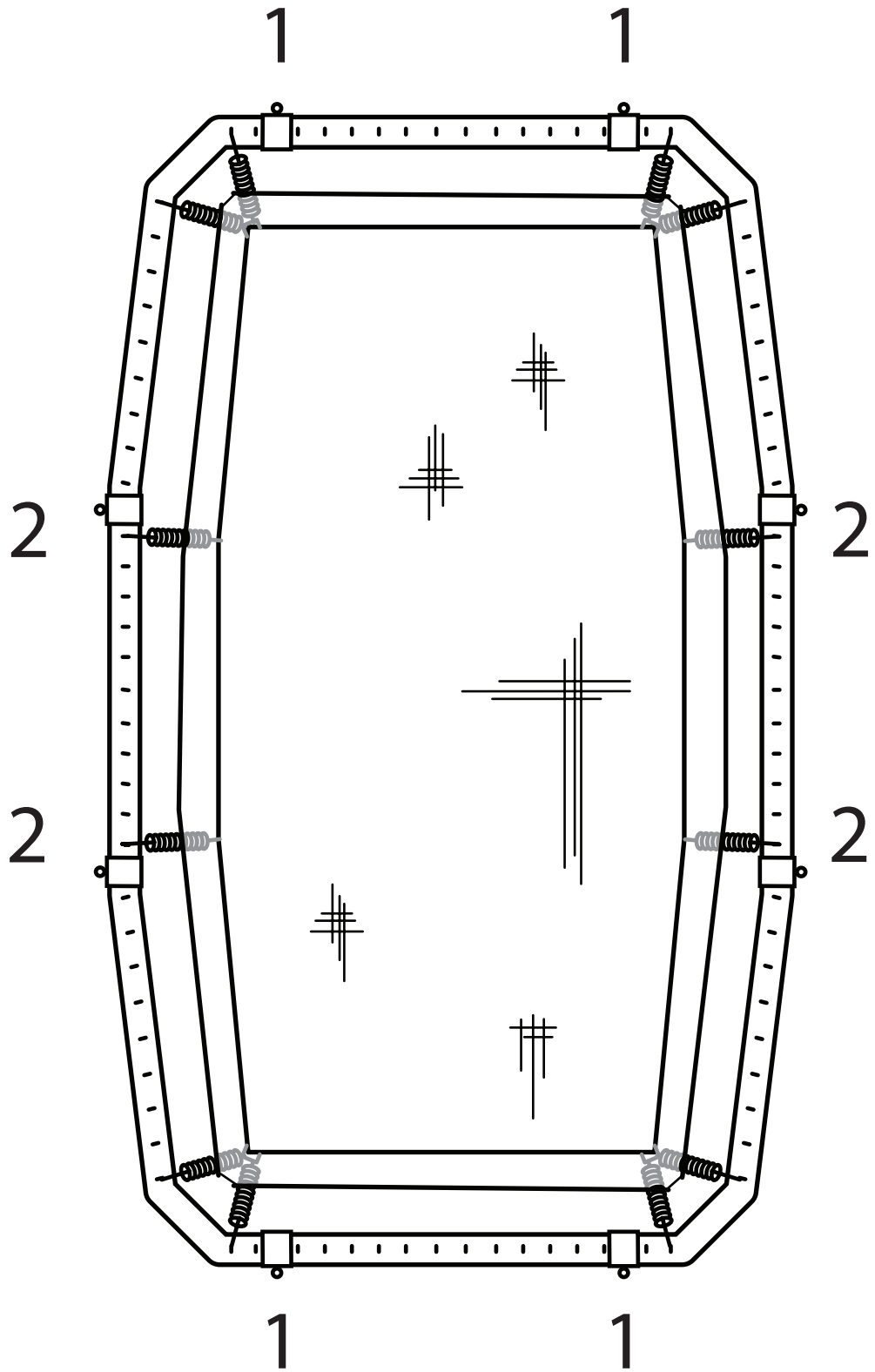

5 ○ ◌ ◻

0%

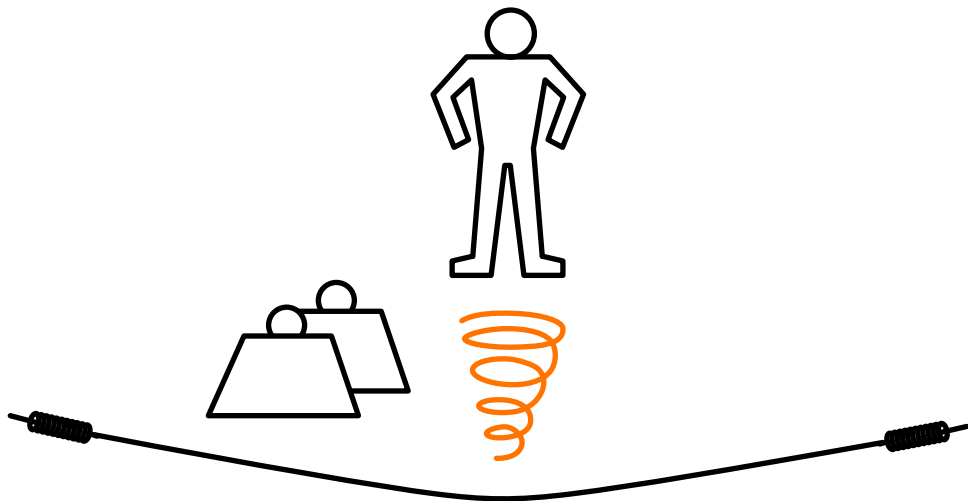

?

50%

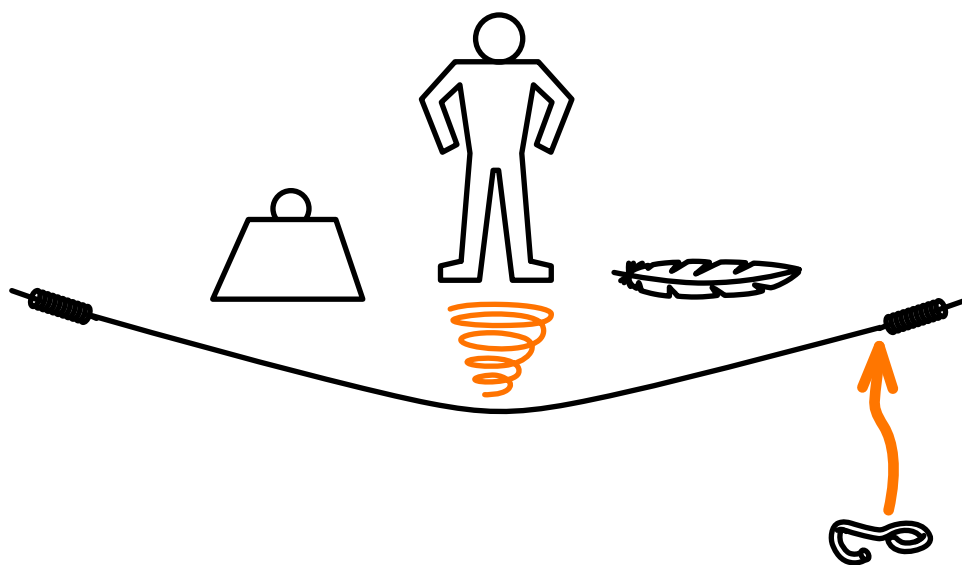

?

100%

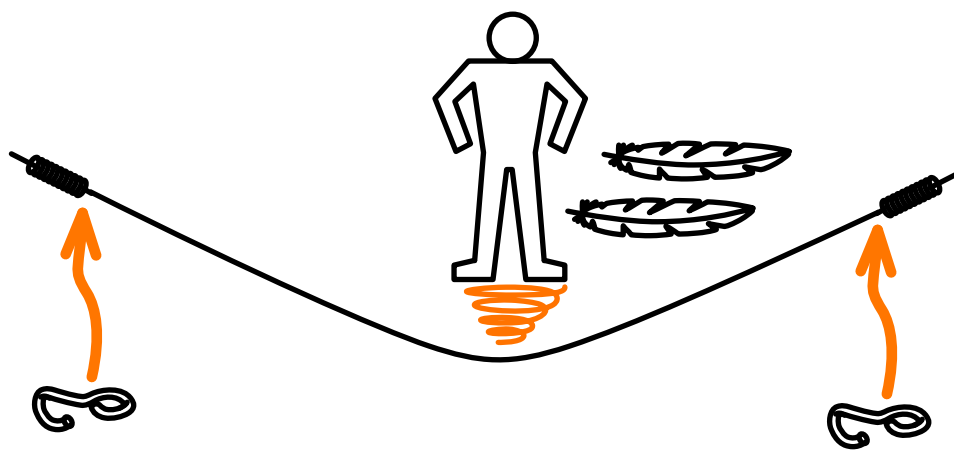

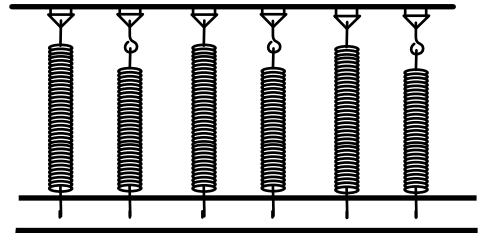
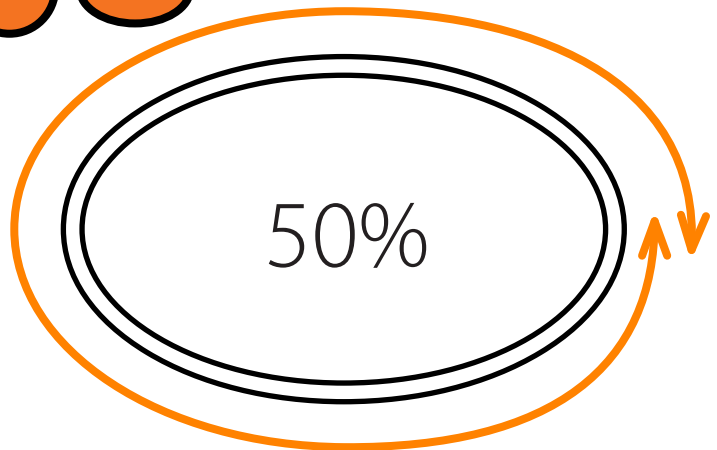
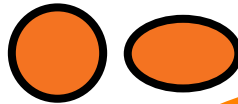
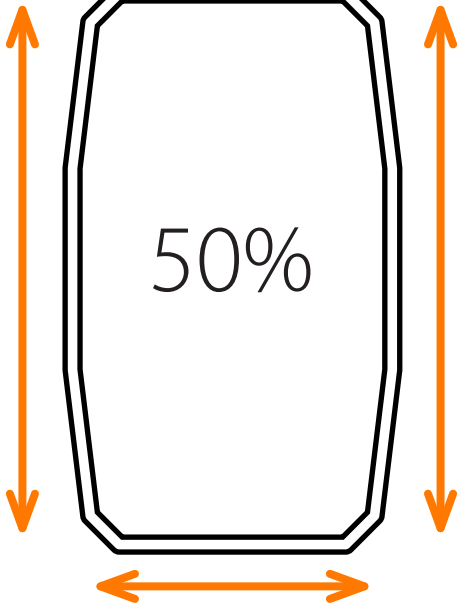
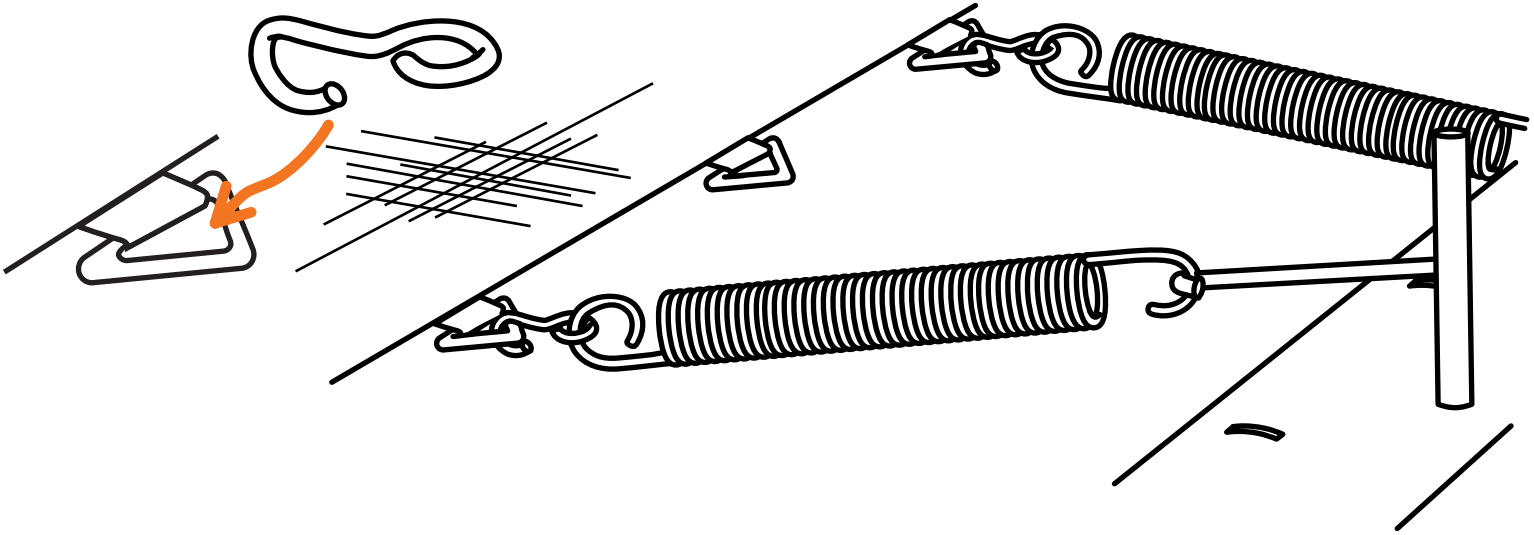
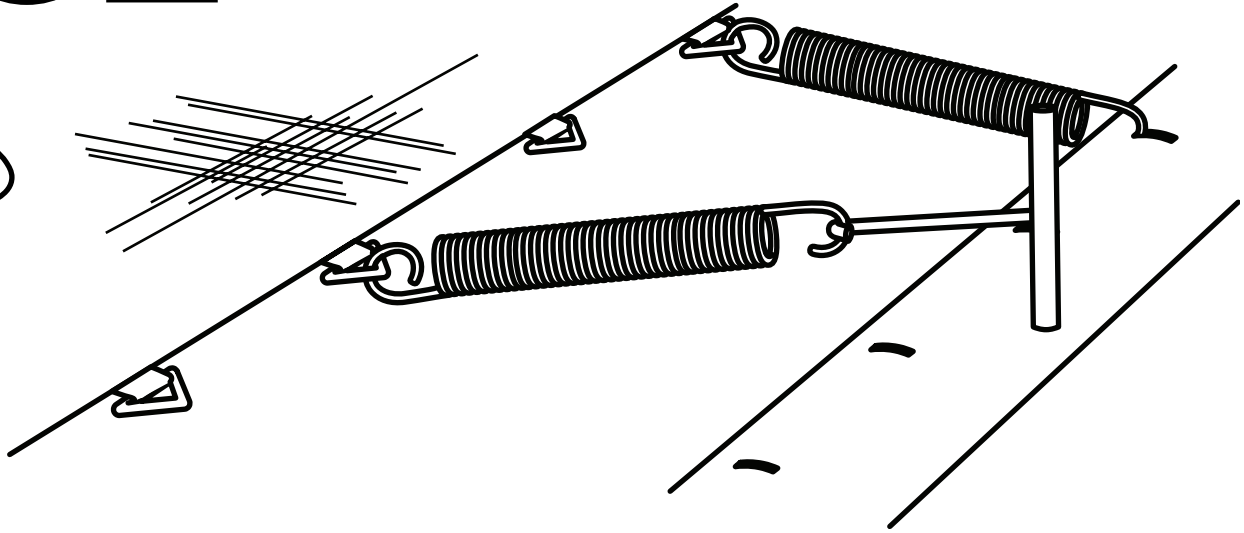
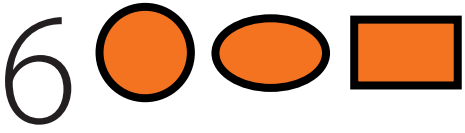

7

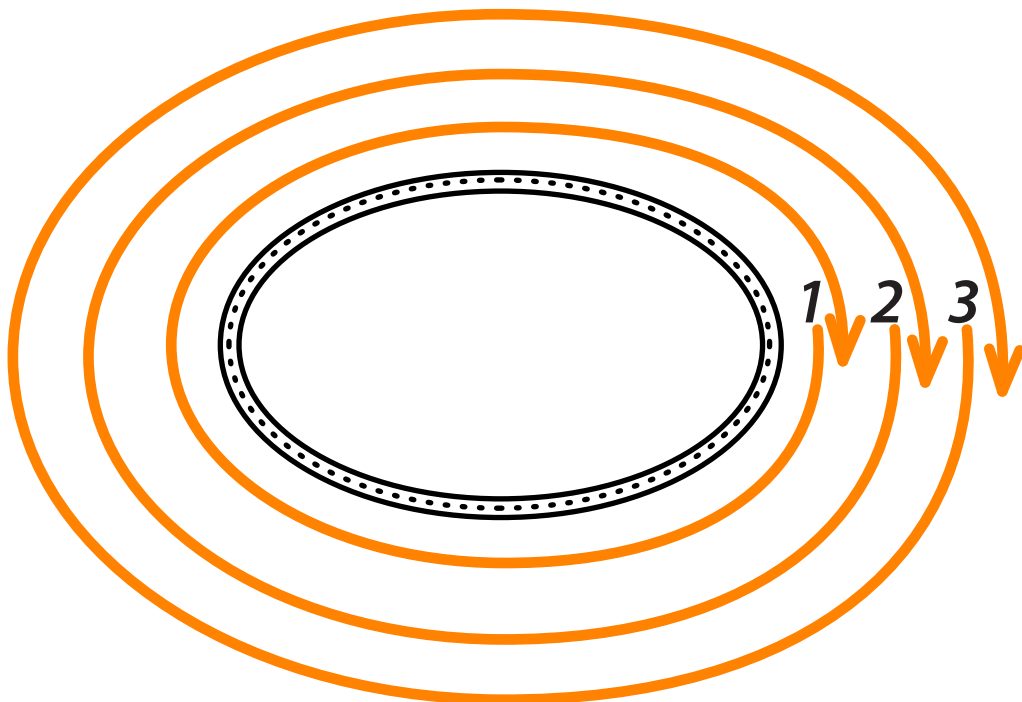
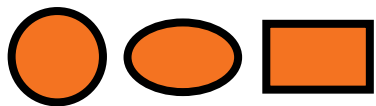

1

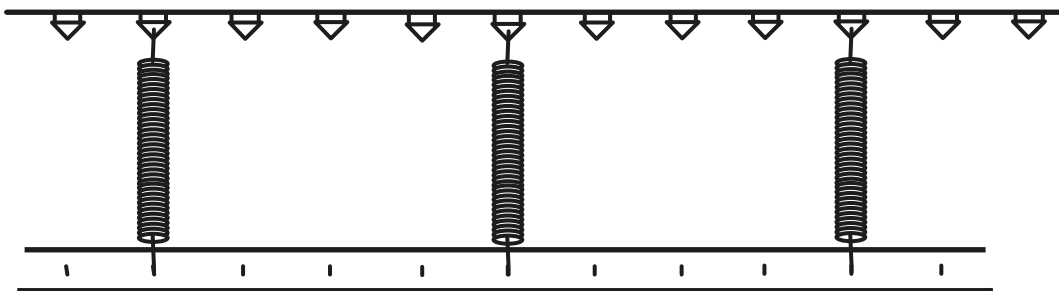

2

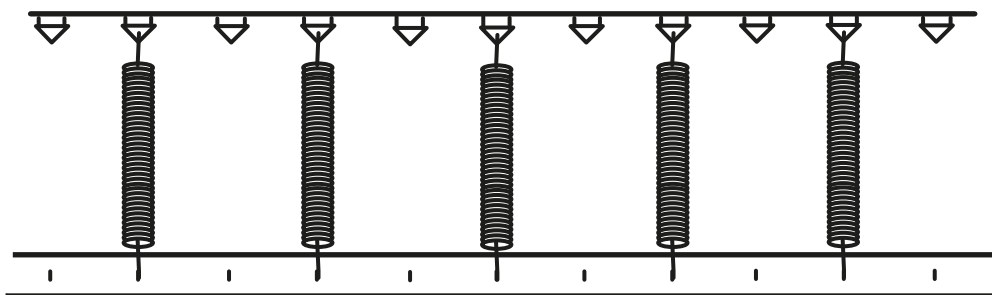

3

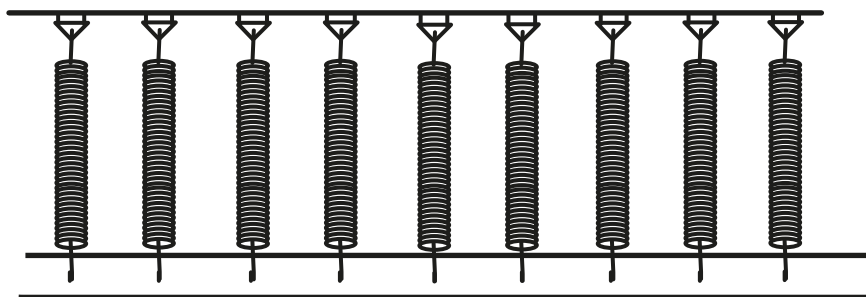

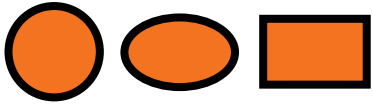

ENG: DO NOT dig before assembling springs and jump mat. The frame contracts and dimensions are altered.

SV: Gräv INTE innan fjädrar och hoppduk blivit monterade. Ramen drar ihop sig under montering.

NO: Grav IKKE før fjærer, og hoppedug er montert. Rammeverket vil trekkes sammen ved montering.

DK: Grav IKKE hullet før I har monteret fjedre og hoppedug da rammen trækker sig sammen ved montering.

FI: ÄLÄ mittaa ja kaiva ennen kuin olet koonnut jouset ja hyppymaton. Runko menee kasaan ja mitat muuttuvat.

DE: NICHT messen und Grube ausheben vor dem Zusammenbau von Federn und Sprungtuch.

Die Rahmenabmessungen ändern sich bei der Montage.

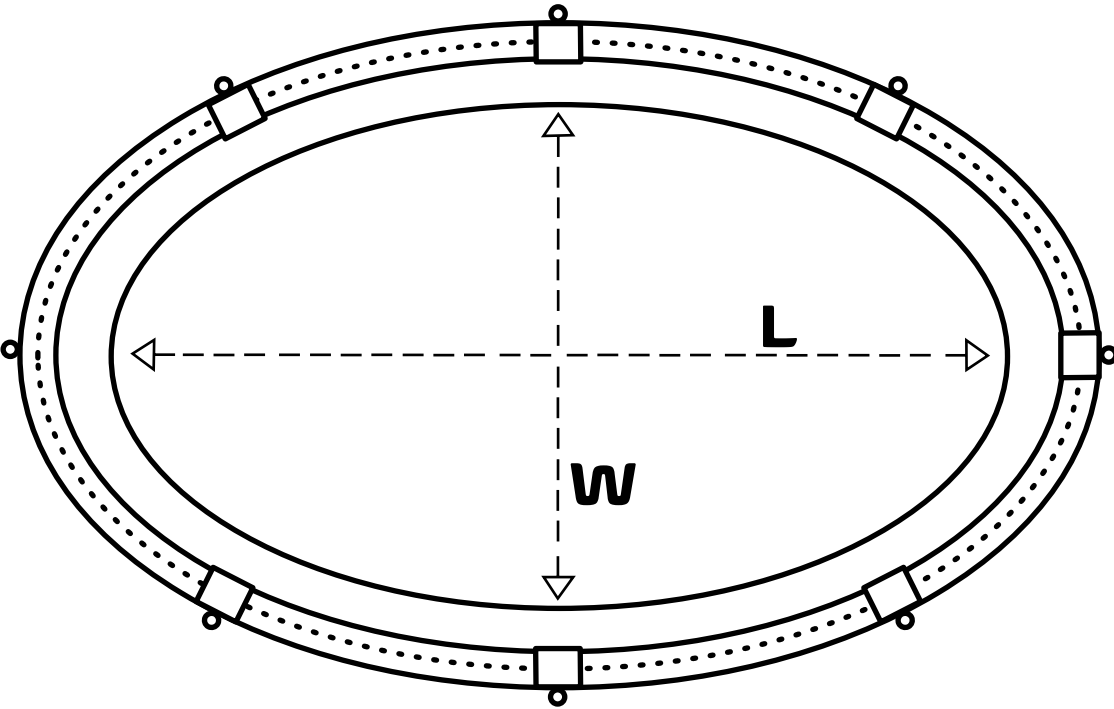

EXPLORER	L	W
300:	2,5m	2,5m
350:	3,0m	1,9m
360:	3,1m	3,1m
420:	3,7m	2,4m
430:	3,8m	3,8m
460:	4,1m	2,6m
500:	4,5 m	2,9m

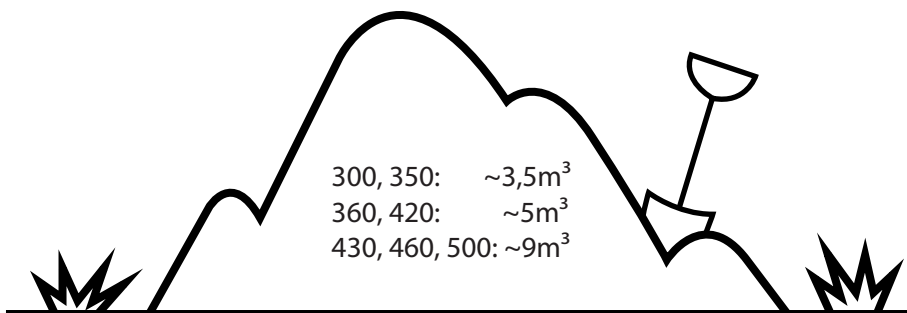
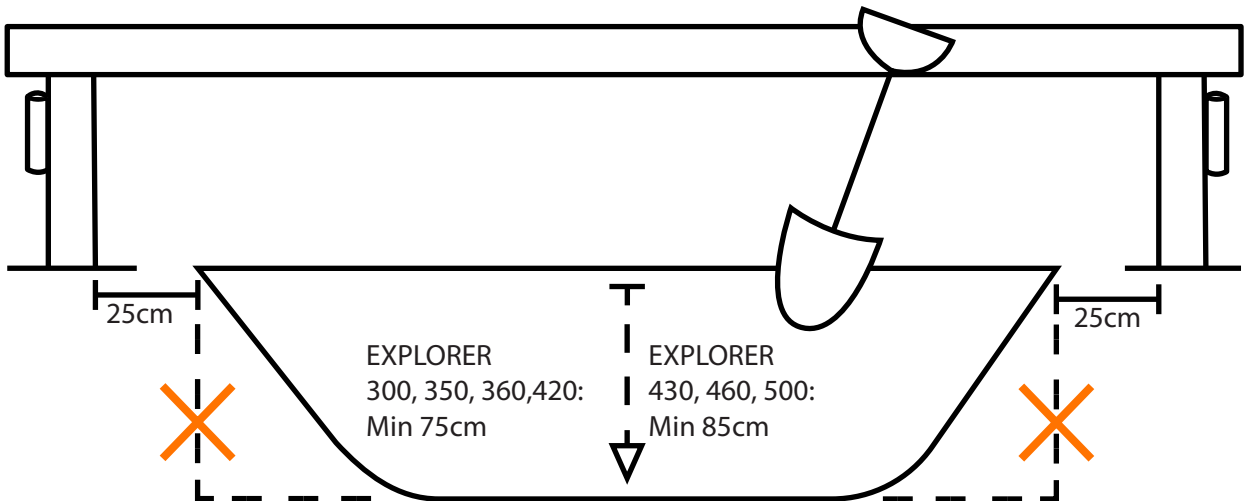

9 ○ ○ □

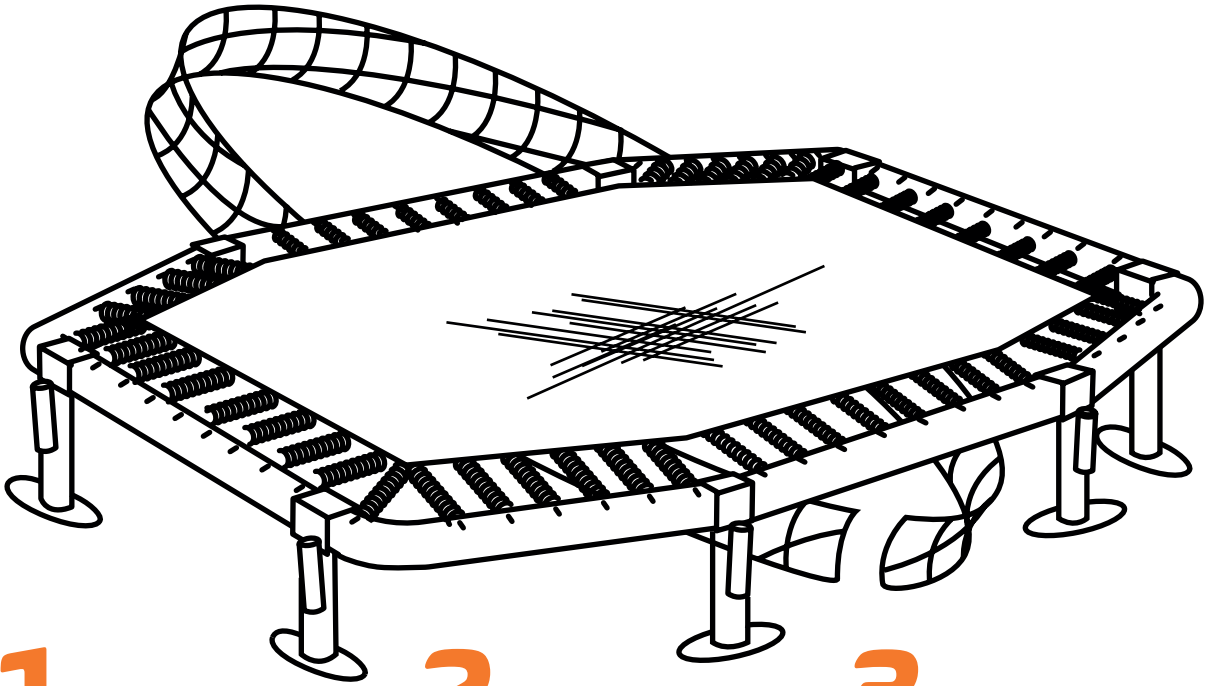

1

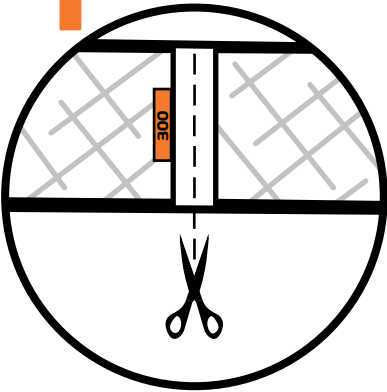

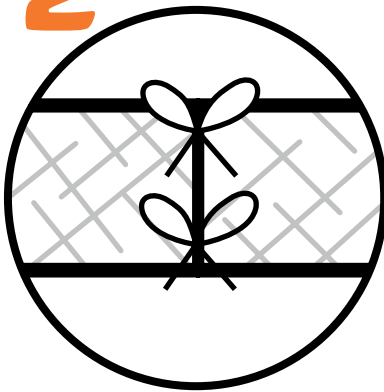

2

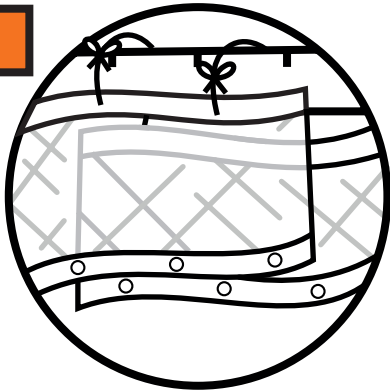
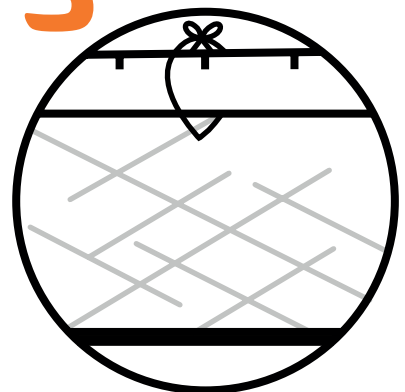

3



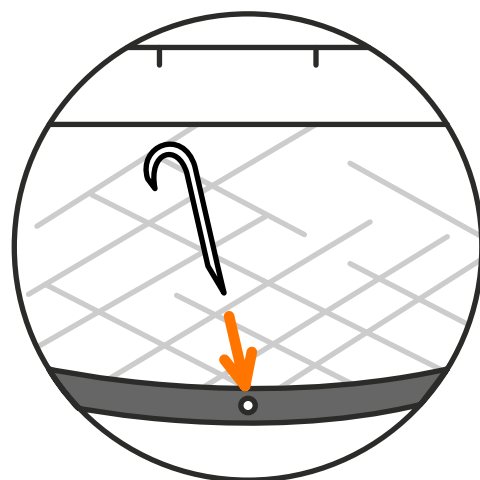
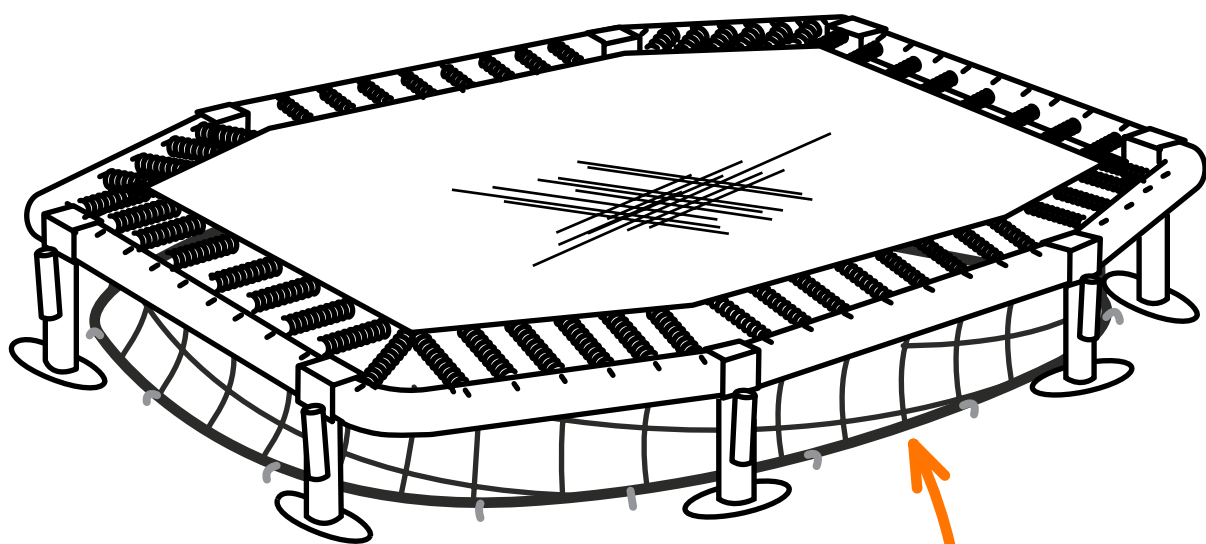

10   

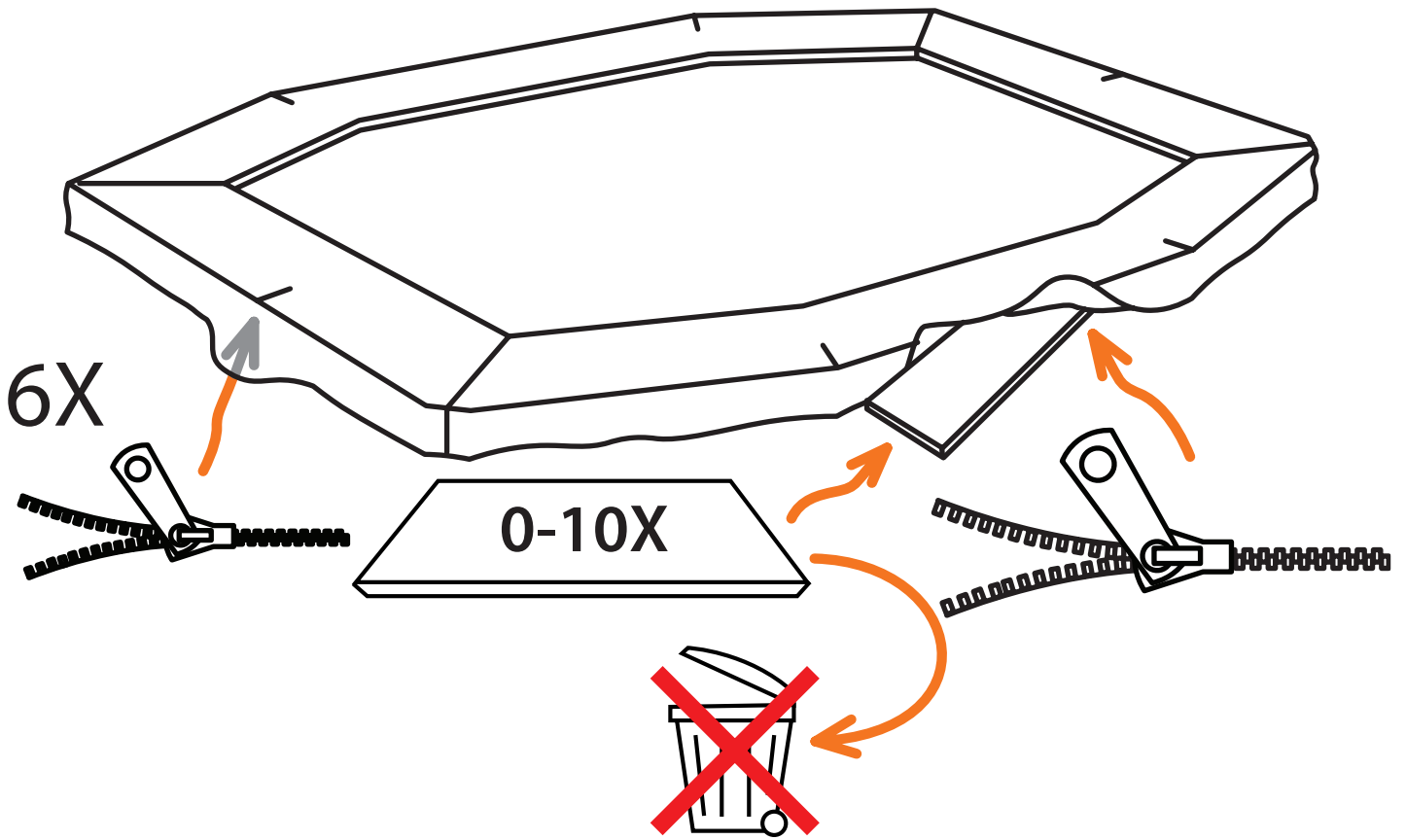

11 



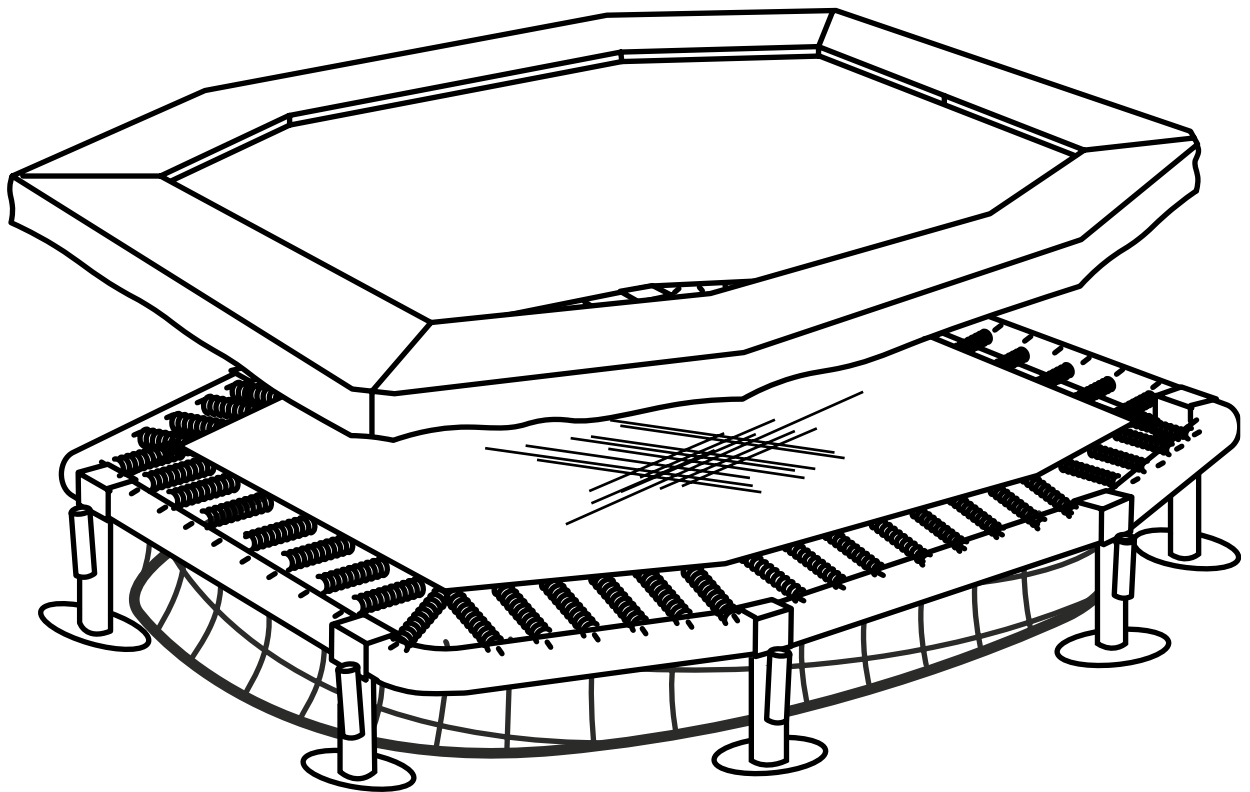

12   

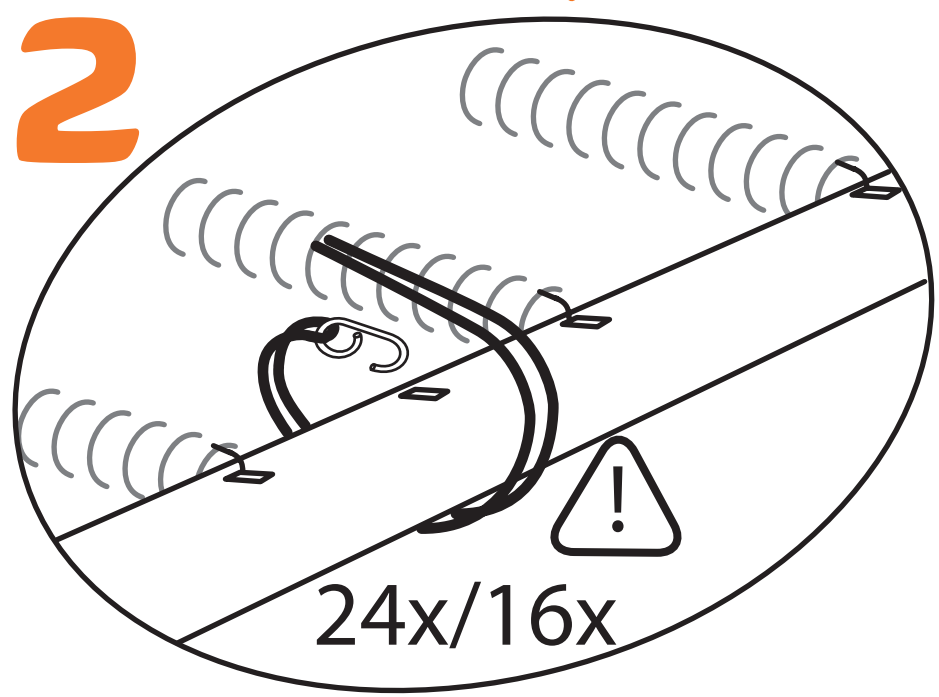
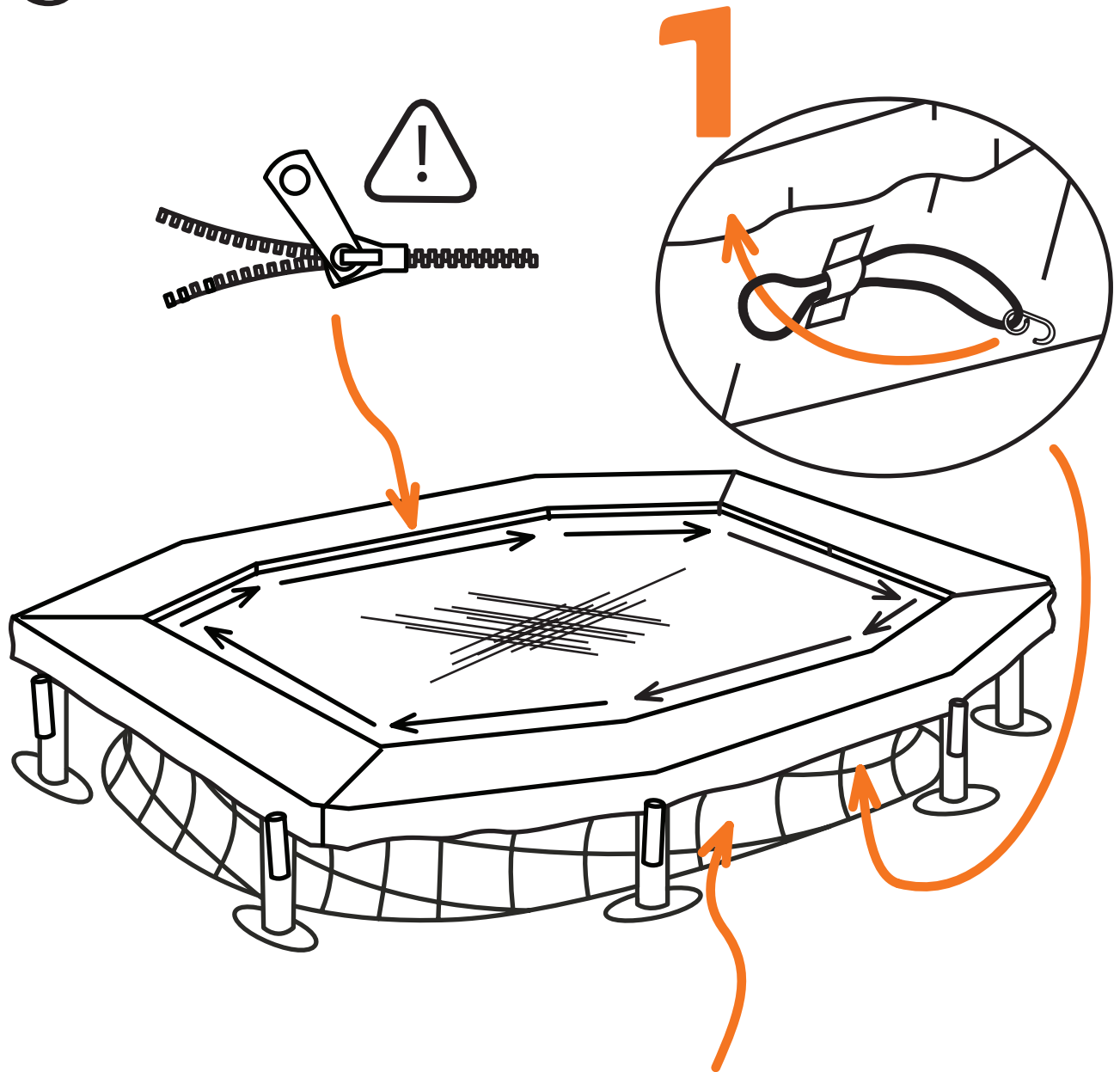

13 ● ○ □



14   

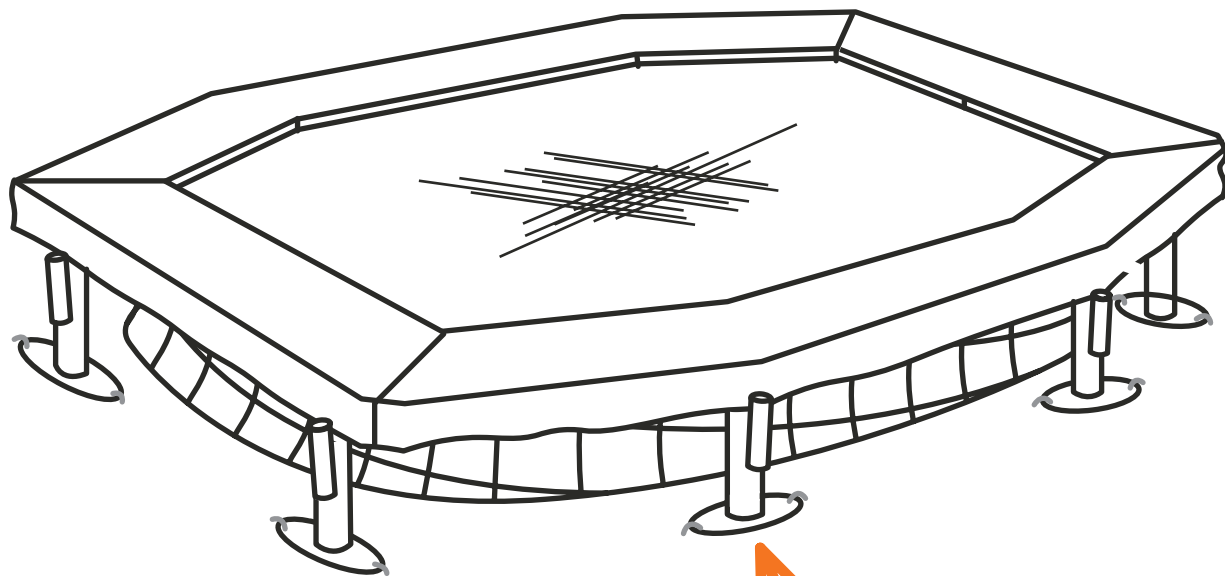

 16x

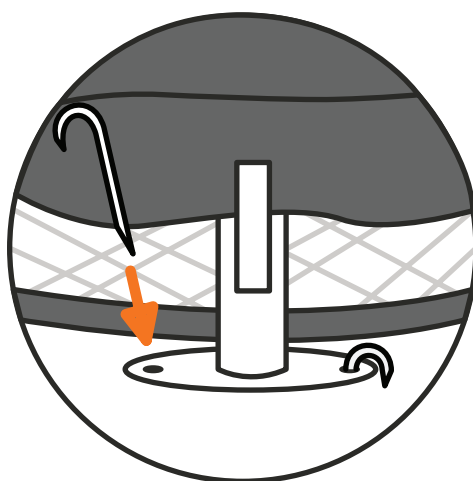

15 ○ ○ □

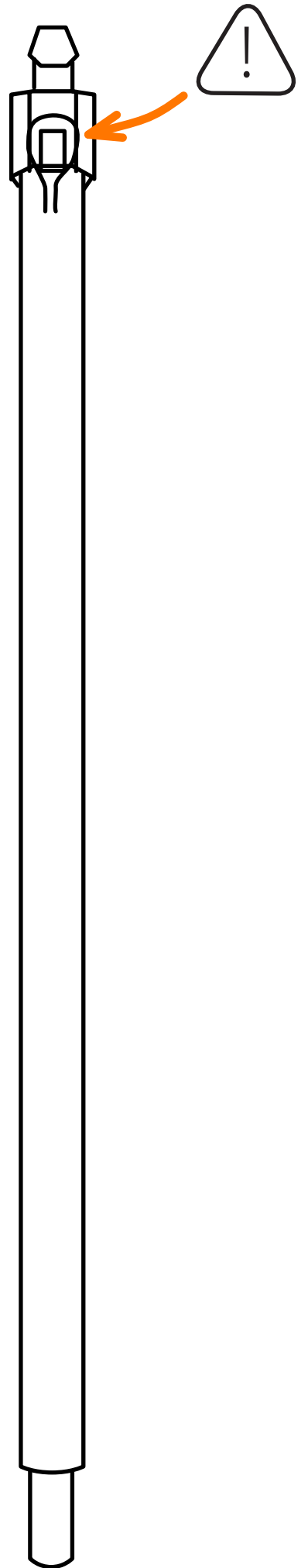
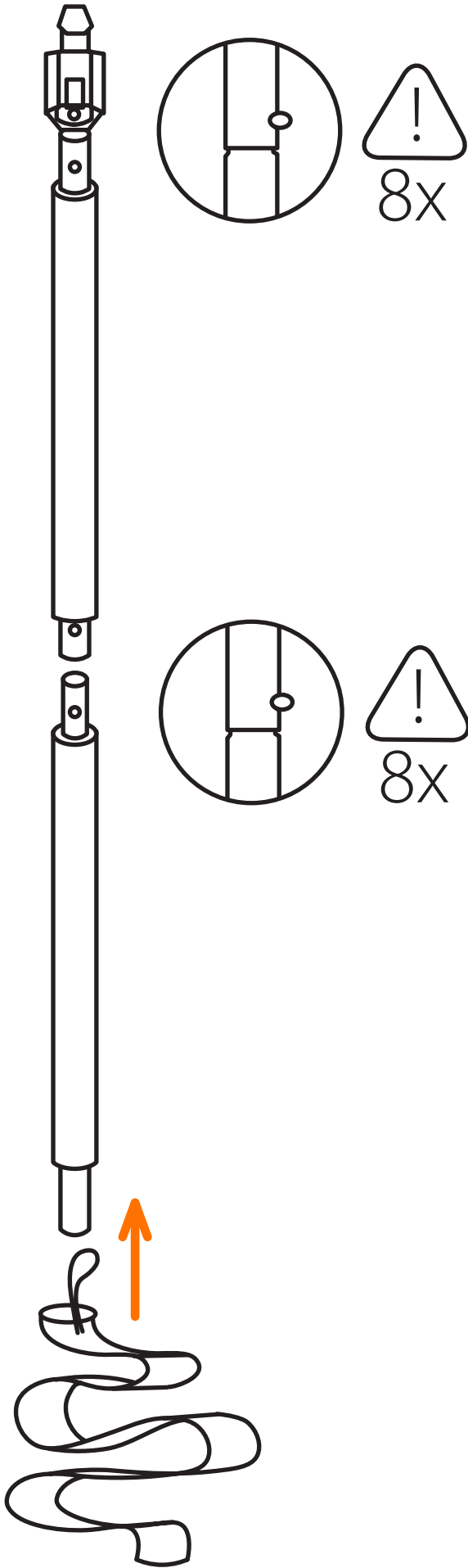

16 ● ○ ■

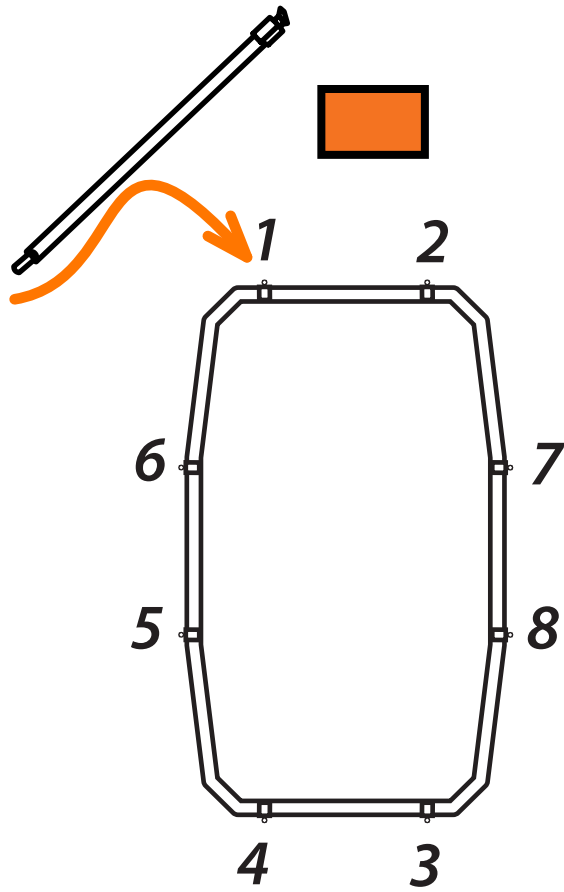
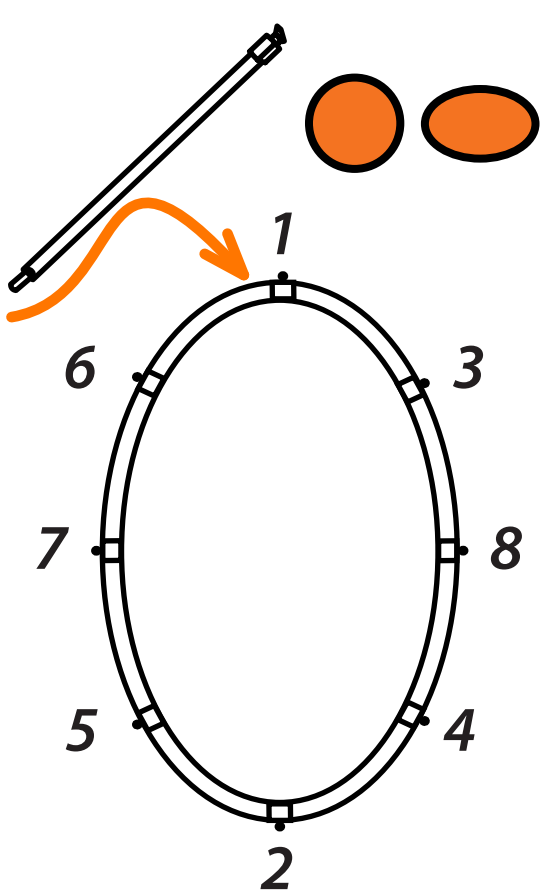
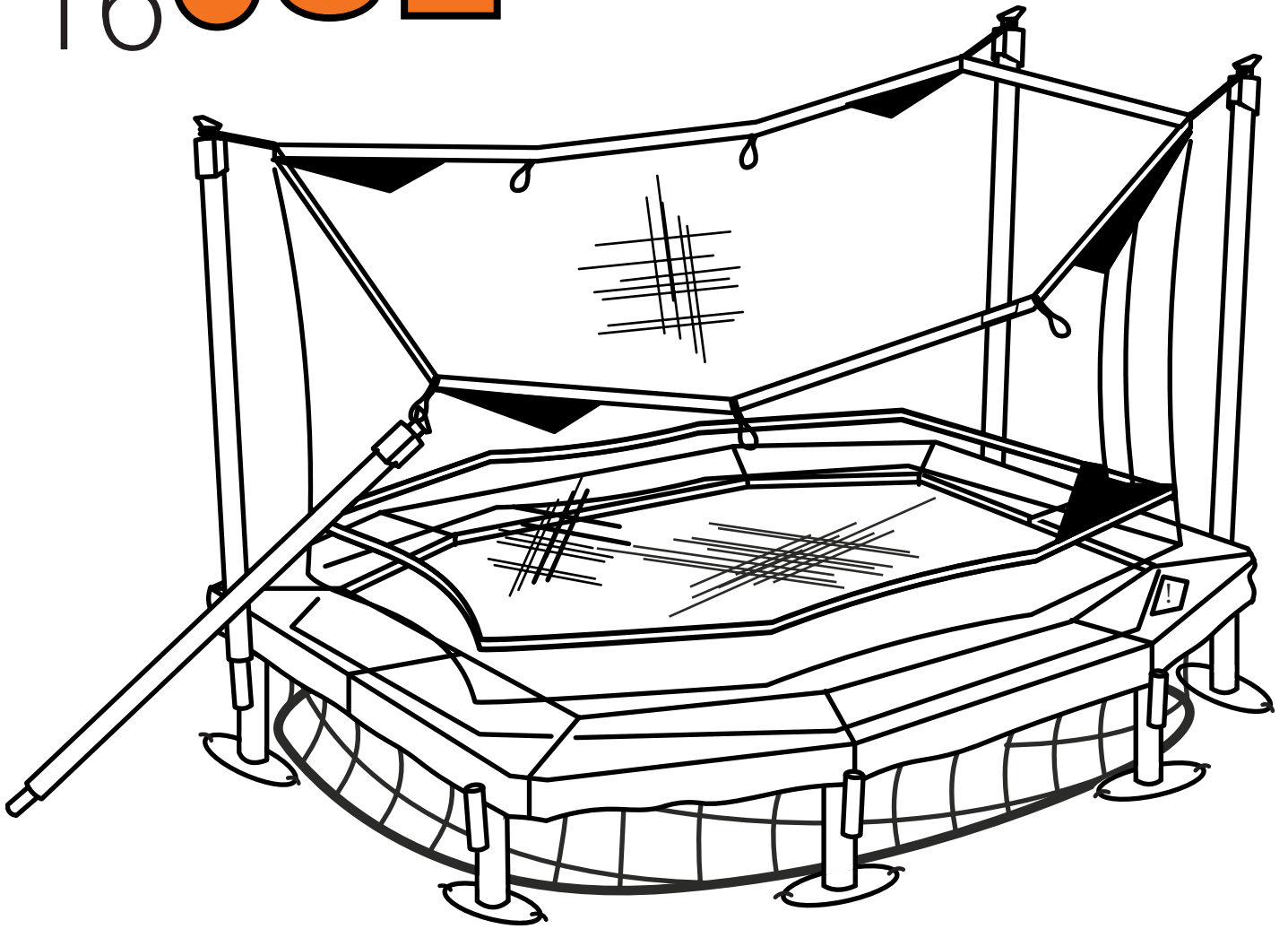

17 ○ ● ◻

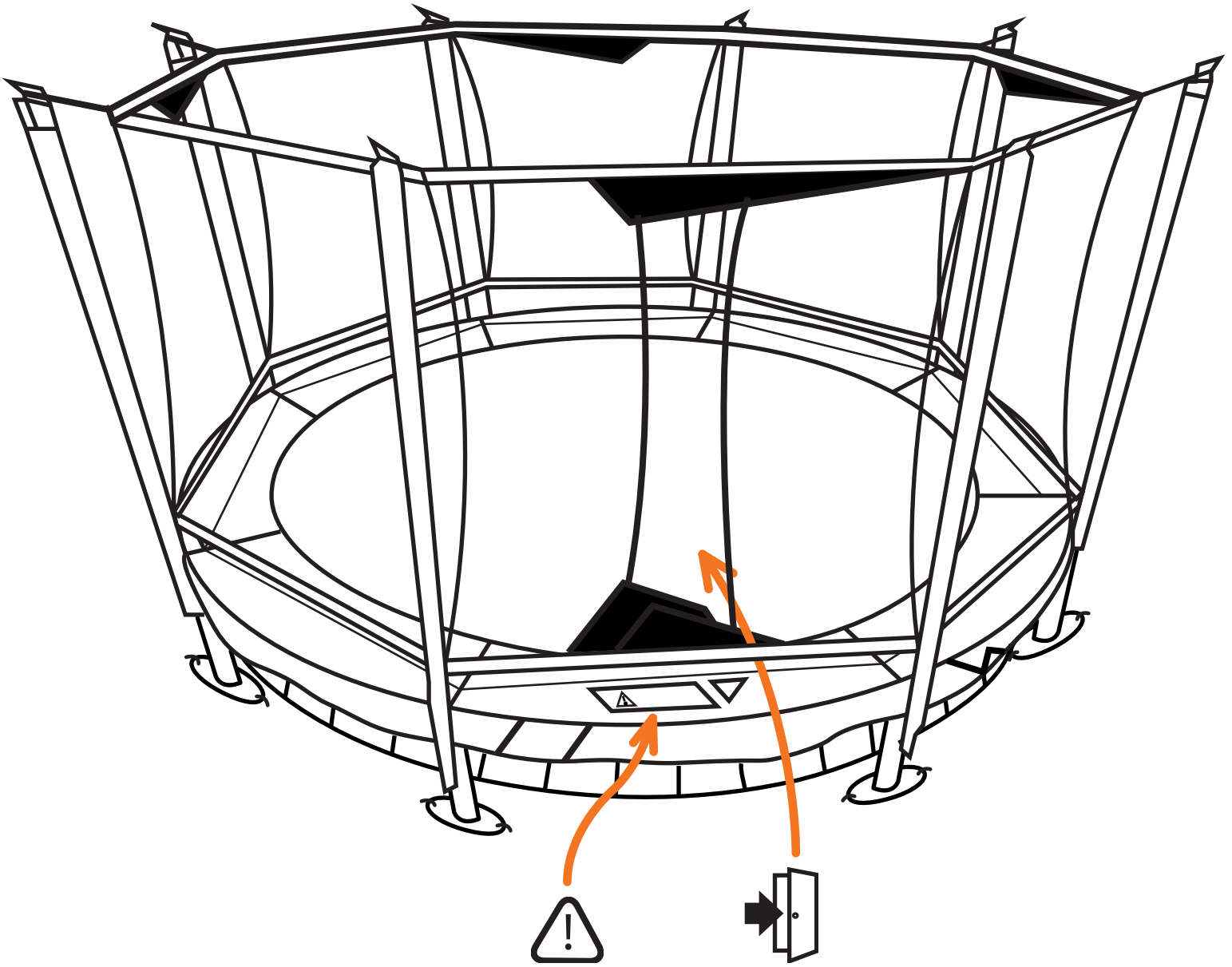

18 ● ○ ■

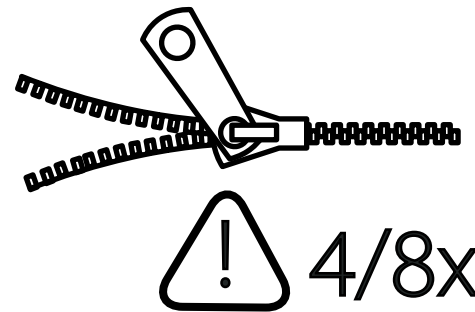
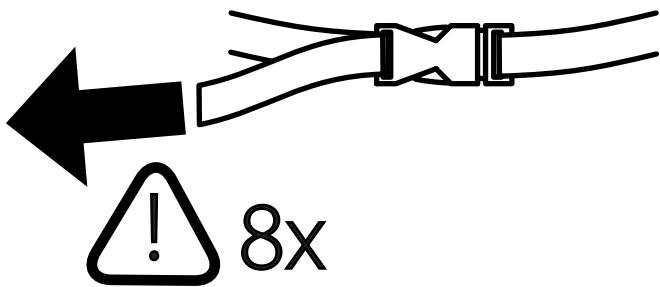
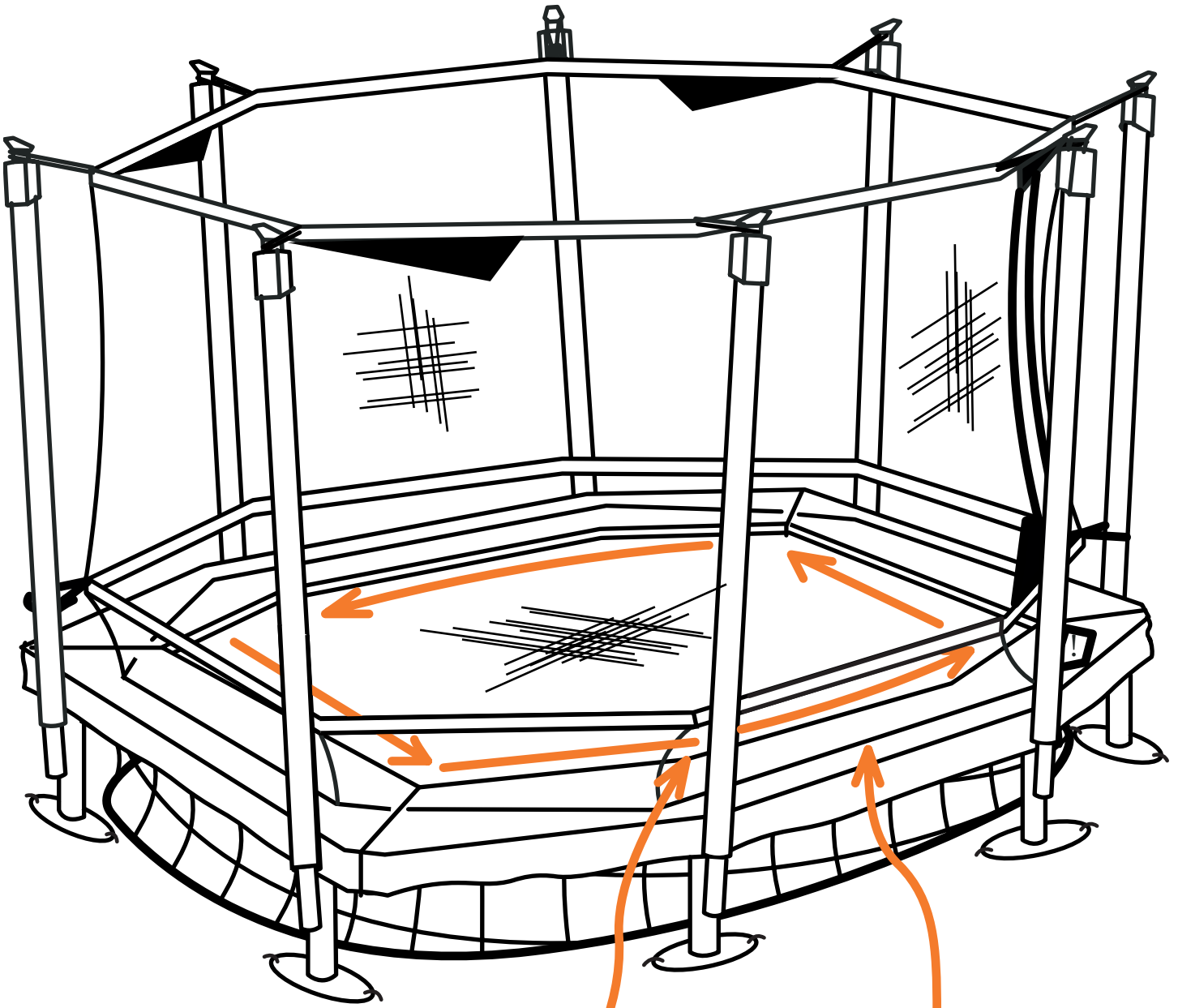

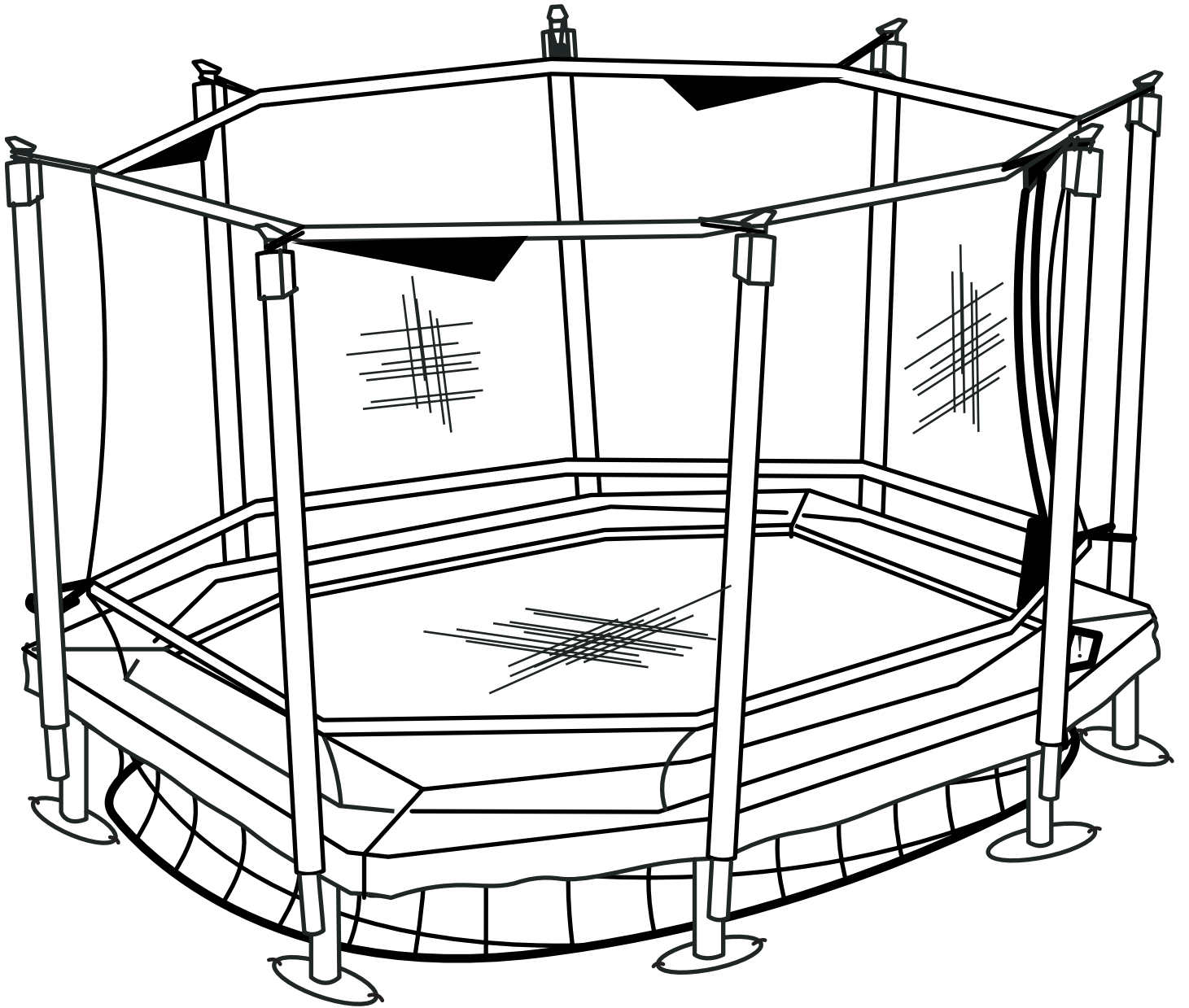

NORTH™ EXPLORER

ENG: DISSEMBLY

To disassemble the trampoline, follow the assembly steps in reverse order.

Do not attempt to disassemble any trampoline frame components before the springs and the trampoline mat have been removed. Use gloves to protect your hands from pinch points during disassembly.

SV: NEDMONTERING:

För att nedmontera studsattan/skyddsnätet, följ de olika stegen för montering i omvänd ordning. Försök inte att ned-montera någon del av studsattans ram innan fjädrarna och hoppduken har avlägsnats. Använd handskar för att skydda dina händer från att klämmas under nedmonteringen.

NO: demontering:

For å demontere trampolinen, følg monteringsstrinn i omvendt rekkefølge. Ikke forsøk å demontere noen rammekomponenter på trampolinen før fjærene og hoppeduken er fjernet. Bruk hansker for å beskytte hendene for klemskader ved demontering.

DK: NEDMONTERING:

For at demontere trampolinen/sikkerhedsnettet skal man følge trinen i modsat rækkefølge. Forsøg ikke at demontere nogen af trampolinrammens dele, før fjedre og hoppedug er blevet fjernet. Bær handsker for at undgå at få klemt fingrene under demonteringen.

FI: PURKAMINEN :

Pura trampoliini seuraamalla kokoamisvaiheita päinvastaisessa järjestyksessä. Älä yritä purkaa trampoliinin rungon osia ennen kuin jouset ja trampoliinimatto on poistettu. Käytä käsineitä suojataksesi kätesi puristuskohdilta purkamisen aikana.

DE: DEMONTAGE:

Zur Demontage des Trampolins/Sicherheitsnetzes befolgen Sie einfach die Montageschritte in umgekehrter Reihenfolge. Versuchen Sie keinesfalls, ein Rahmenteil des Trampolins zu demontieren, bevor Sie die Federn und das Sprungtuch entfernt haben. Tragen Sie Handschuhe, um Ihre Hände während der Montage vor Quetschungen zu schützen.



