

# INSTRUCTIONS

64678 Current Bike Rack / Porte-vélos

Page 1 | 9



## REQUIRED TOOLS / OUTILS REQUIS

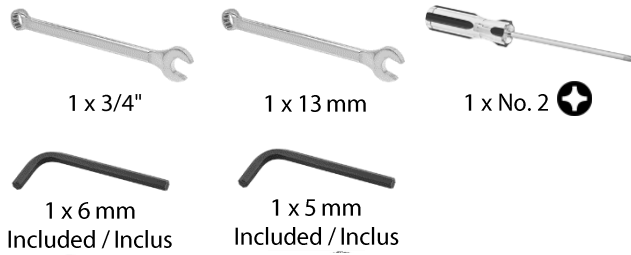

## CAPACITY / CAPACITÉ



60 lb per bike / livres par vélo

120 lb / livres maximum

## COMPATIBILITY / COMPATIBILITÉ

66690 Bike Ramp / Rampe de Vélo

NO.	DESCRIPTION	QTY
A	HITCH BAR ASSEMBLY / ASSEMBLAGE DE LA BARRE D'ATTELAGE	1
B	UPRIGHT BAR ASSEMBLY / ASSEMBLAGE DE BARRE VERTICALE	1
C	M8 x 1.25 x 75 CARRIAGE BOLT / ÉCROU DU CHARIOT	2
D	M8 x 1.25 x 50 CARRIAGE BOLT / ÉCROU DU CHARIOT	4
E	M8 LOCK WASHER / RONDELLE DE VERROUILLAGE	7
F	M8 x 1.25 NUT / ÉCROU	7
G	LEFT HORIZONTAL BAR / BARRE HORIZONTALE GAUCHE	2
H	RIGHT HORIZONTAL BAR / BARRE HORIZONTALE DROITE	2
I	HORIZONTAL BAR CAP / BOUCHON DE BARRE HORIZONTALE	2
J	LONG FRAME HOOK / CROCHET DE CHÂSSIS LONG	1
K	SHORT FRAME HOOK / CROCHET DE CHÂSSIS COURT	1
L	RIGHT REAR WHEEL HOLDER / SUPPORT DE ROUE ARRIERE DROITE	1
M	RIGHT FRONT WHEEL HOLDER / SUPPORT DE ROUE AVANT DROIT	1
N	LEFT FRONT WHEEL HOLDER / SUPPORT DE ROUE AVANT GAUCHE	1
O	LEFT REAR WHEEL HOLDER / SUPPORT DE ROUE ARRIERE GAUCHE	1
P	SET SCREW / VIS DE RÉGLAGE	4
Q	1/2" BSW LOCKING THREADED HITCH PIN / GOUPILLE D'ATTELAGE FILETÉE DE VERROUILLAGE	1
R	1/2" BSW THREADED HITCH PIN / GOUPILLE D'ATTELAGE FILETÉE	1
S	1/2" LOCK WASHER / RONDELLE DE VERROUILLAGE	1
T	COTTER PIN / GOUPILLE	1
U	M10 x 1.5 x 50 FLAT HEAD SCREW / VIS À TÊTE PLATE	1
V	2" HITCH ADAPTER LEFT / ADAPTATEUR D'ATTELAGE GAUCHE	1
W	2" HITCH ADAPTER RIGHT / ADAPTATEUR D'ATTELAGE DROIT	1
X	GUSSET / GOUSSET	1
Y	M8 x 1.25 x 20 BUTTON HEAD SCREW / VIS A TETE BOUTON	1
Z	SET SCREW WASHER / RONDELLE POUR VIS DE RÉGLAGE	4

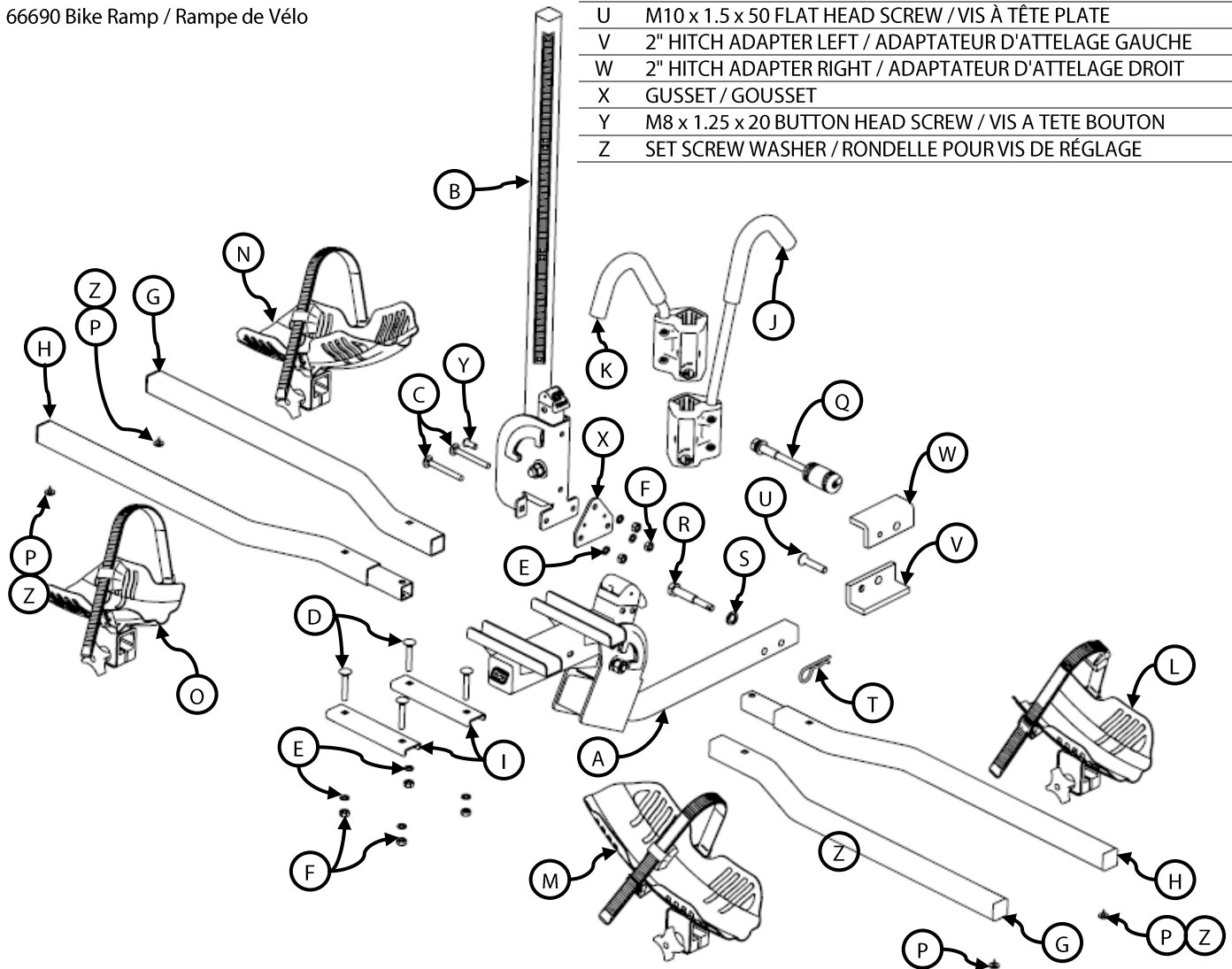

# INSTRUCTIONS

64678 Current Bike Rack / Porte-vélos  
Page 2 | 9



## ASSEMBLY / ASSEMBLAGE

1

NO.	QTY
A	1
B	1

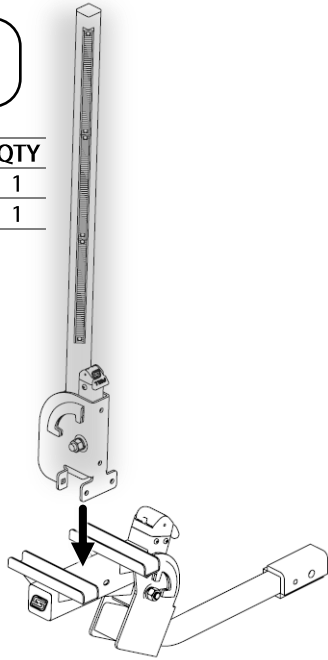

NO.	QTY
C	2
E	3
F	3
X	1
Y	1

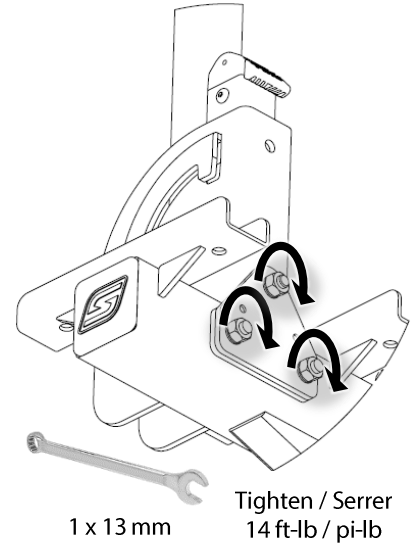
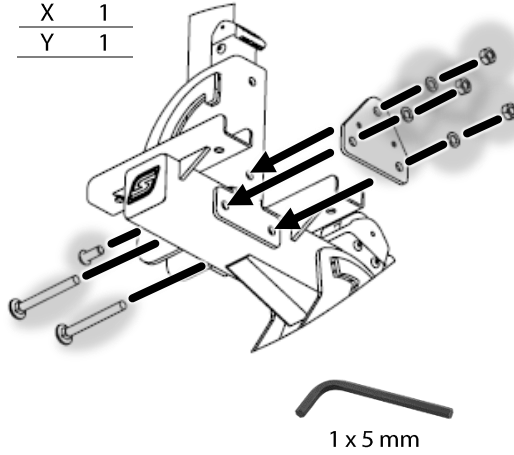

2

NO.	QTY
G	2
H	2

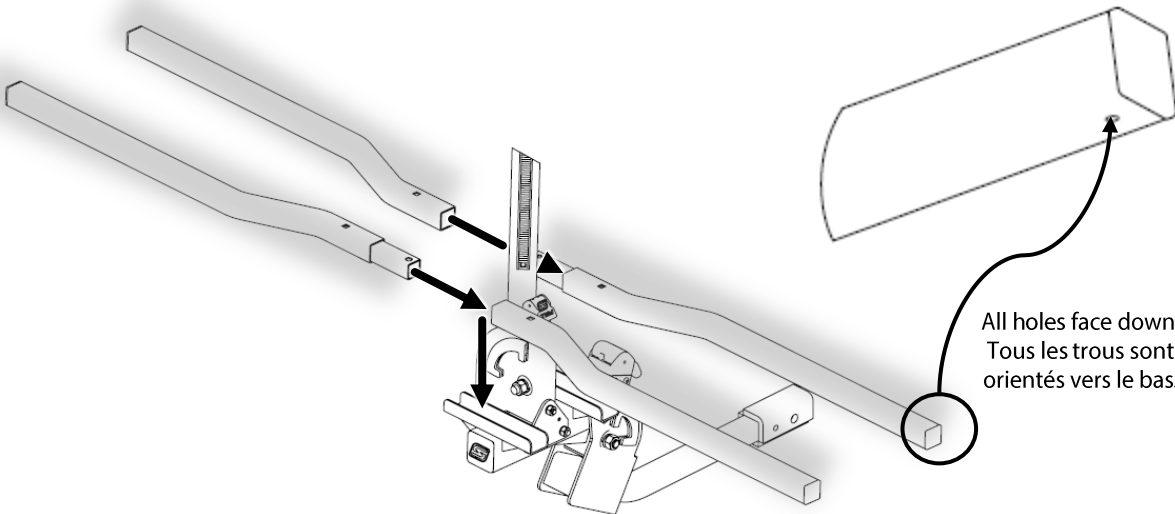

NO.	QTY
D	4
I	2

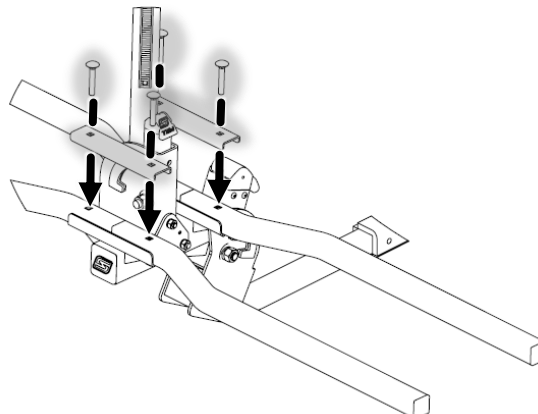

# INSTRUCTIONS

64678 Current Bike Rack / Porte-vélos  
Page 3 | 9



**3**

NO.	QTY
E	4
F	4

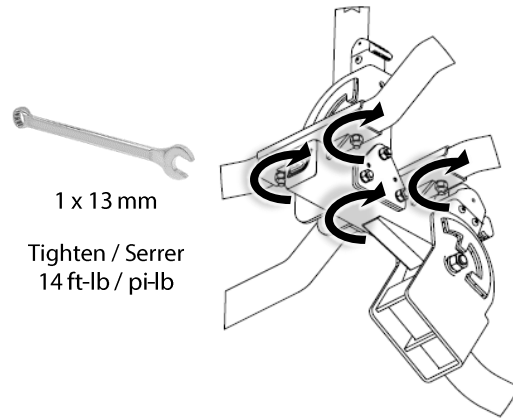
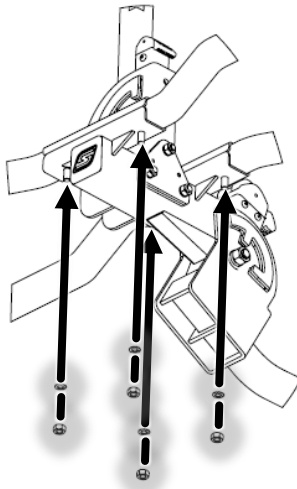

**4**

NO.	QTY
J	1

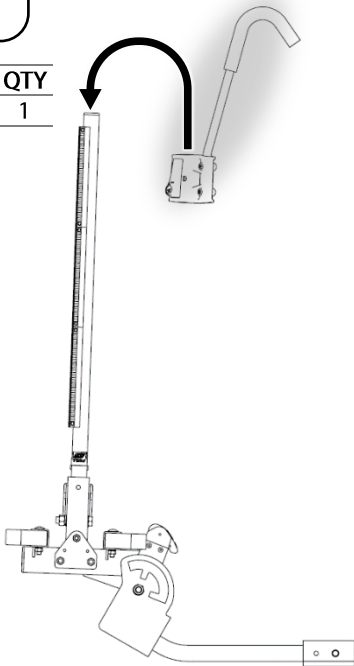

NO.	QTY
K	1

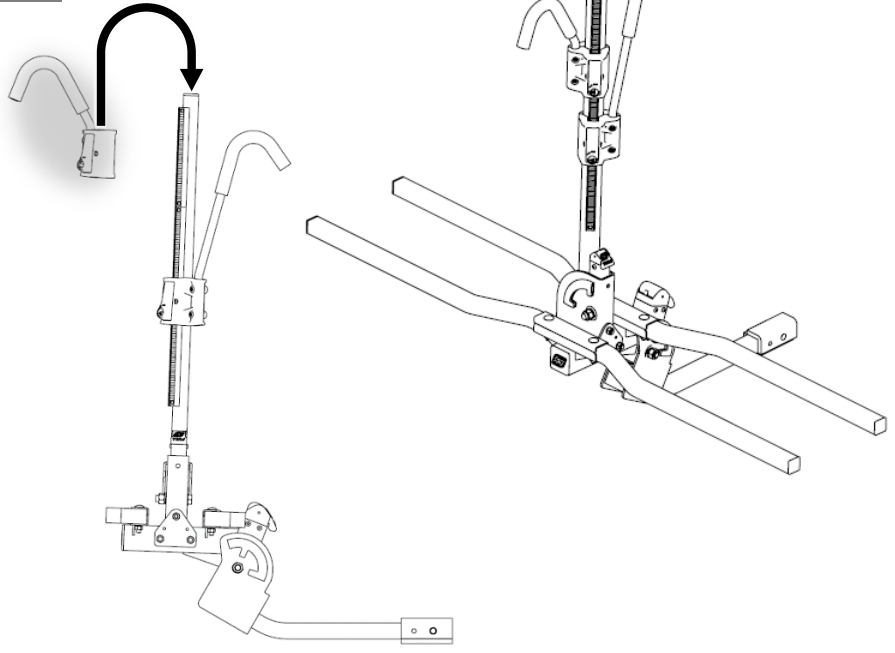

**5**

NO.	QTY
L	1
M	1
N	1
O	1

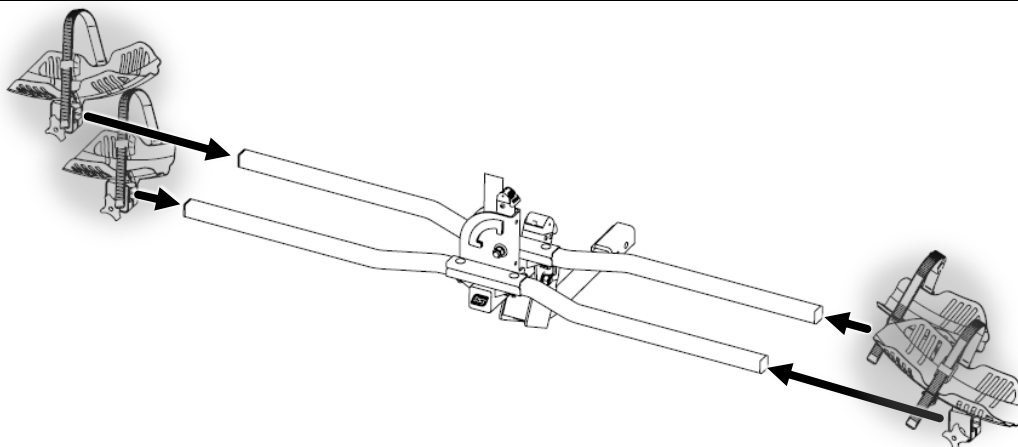

# INSTRUCTIONS

64678 Current Bike Rack / Porte-vélos  
Page 4 | 9



6

NO.	QTY
P	4
Z	4

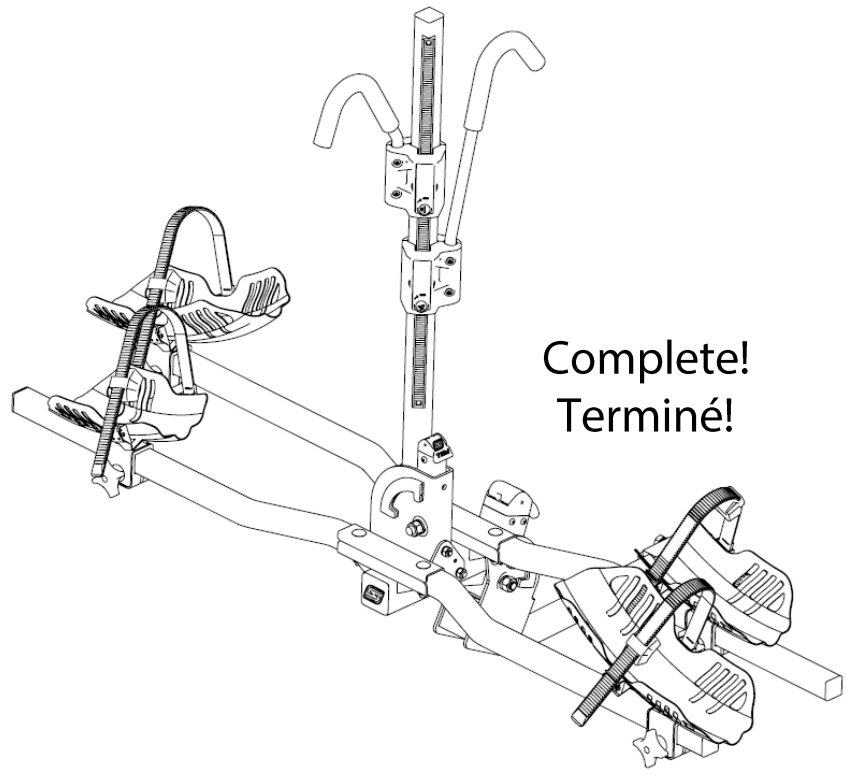
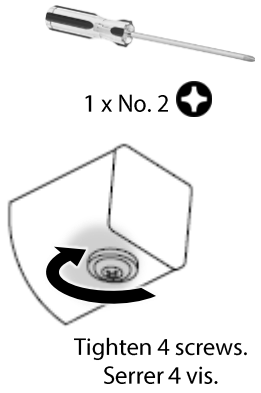
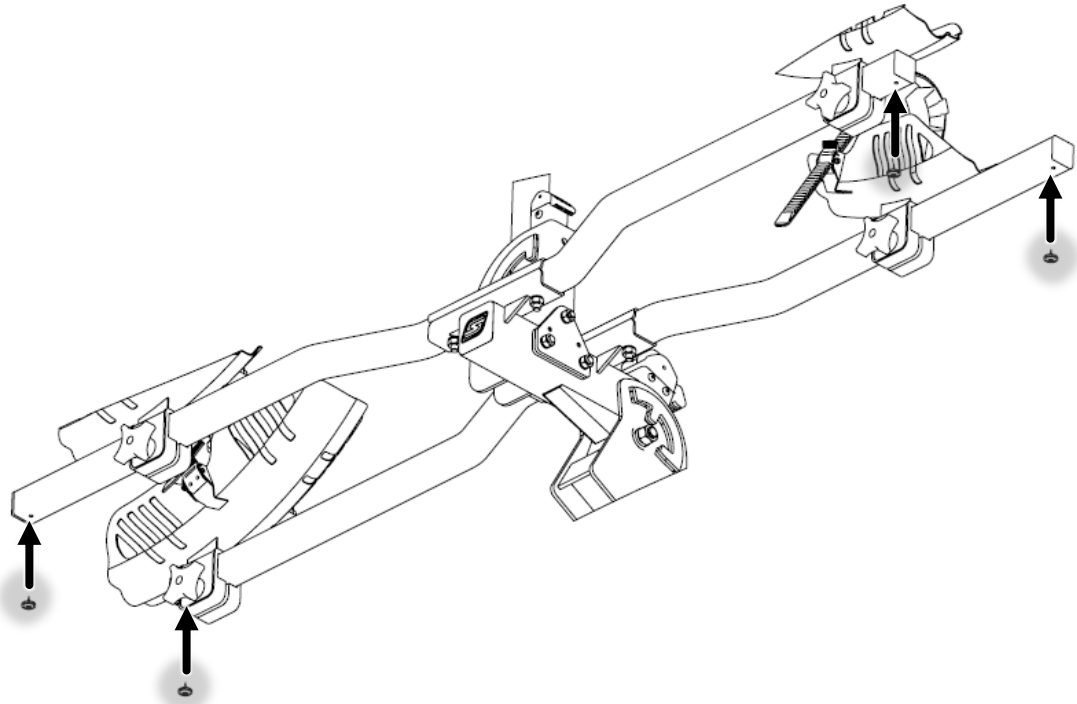

# INSTRUCTIONS

64678 Current Bike Rack / Porte-vélos  
Page 5 | 9



## VEHICLE INSTALLATION / INSTALLATION DU VÉHICULE

**1**

NO.	QTY
A	1

✓ **2" Hitch Receiver**

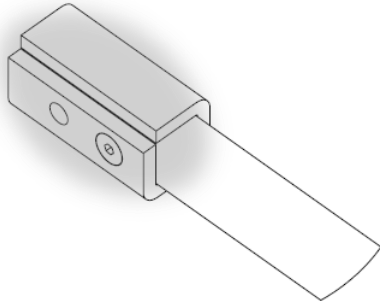

NO.	QTY
U	1

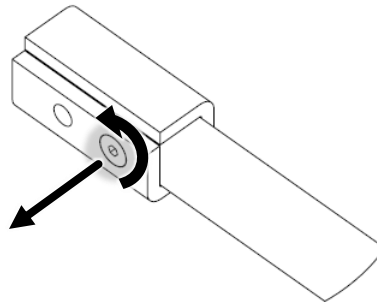

✓ **1 1/4" Hitch Receiver**

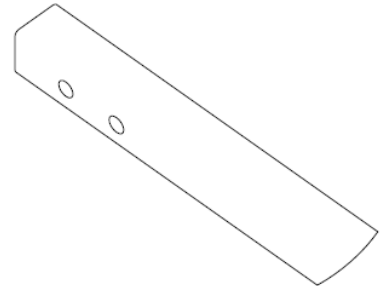

NO.	QTY
V	1
W	1

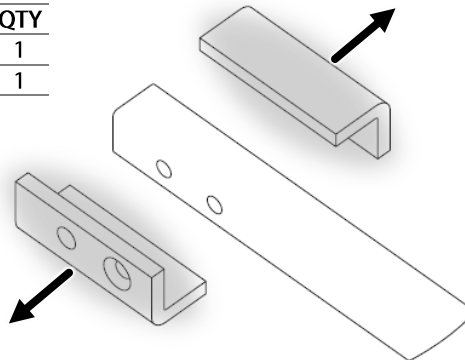

**2**

NO.	QTY
Q	1
Or / Ou	
R	1
S	1
T	1

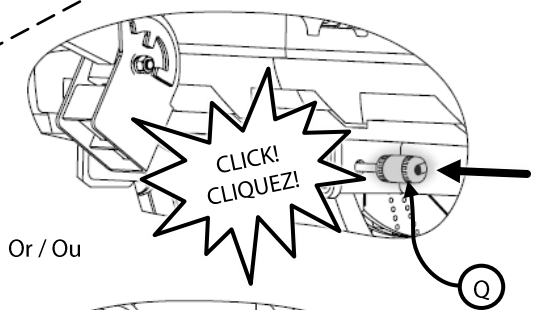
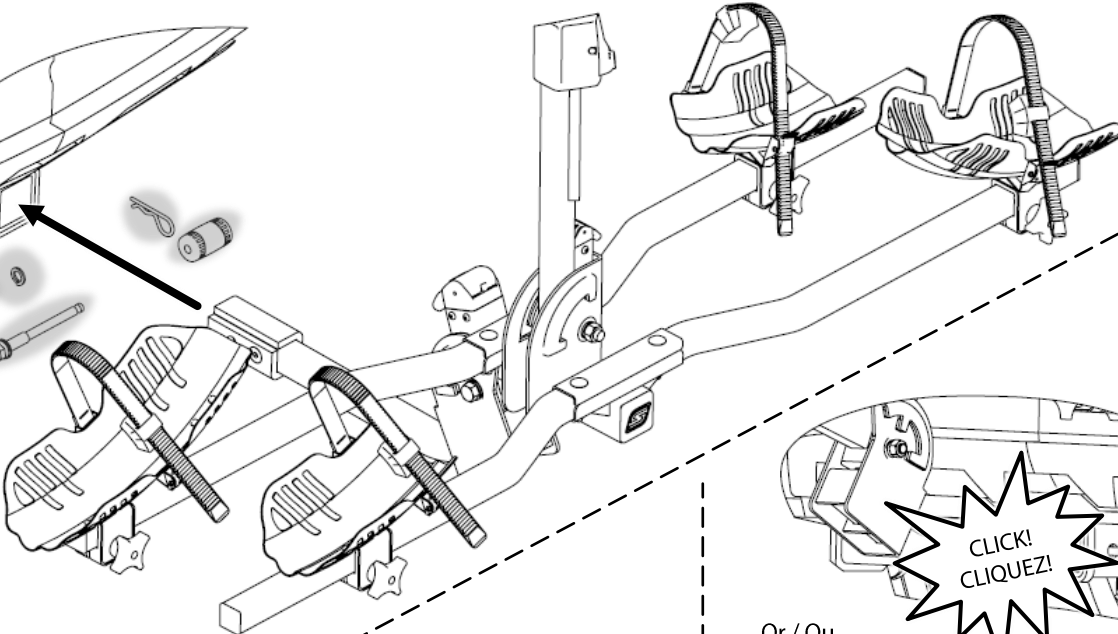
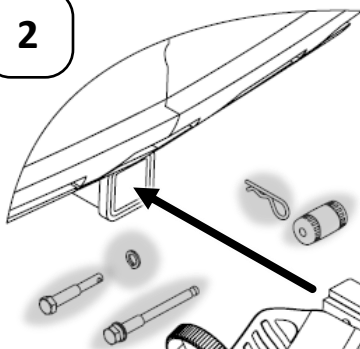

Or / Ou

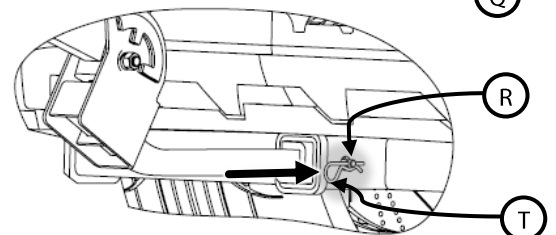

Tighten / Serrer  
50 ft-lb / pi-lb



# INSTRUCTIONS

64678 Current Bike Rack / Porte-vélos  
Page 6 | 9



## FOLDING / REPLIEMENT

1

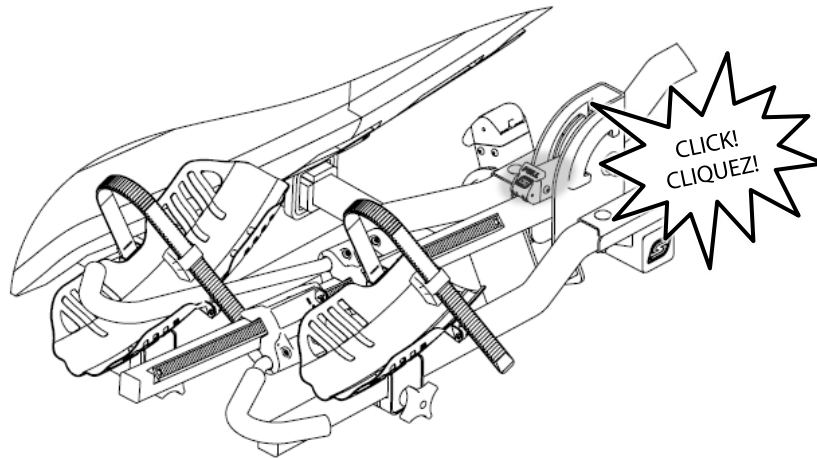
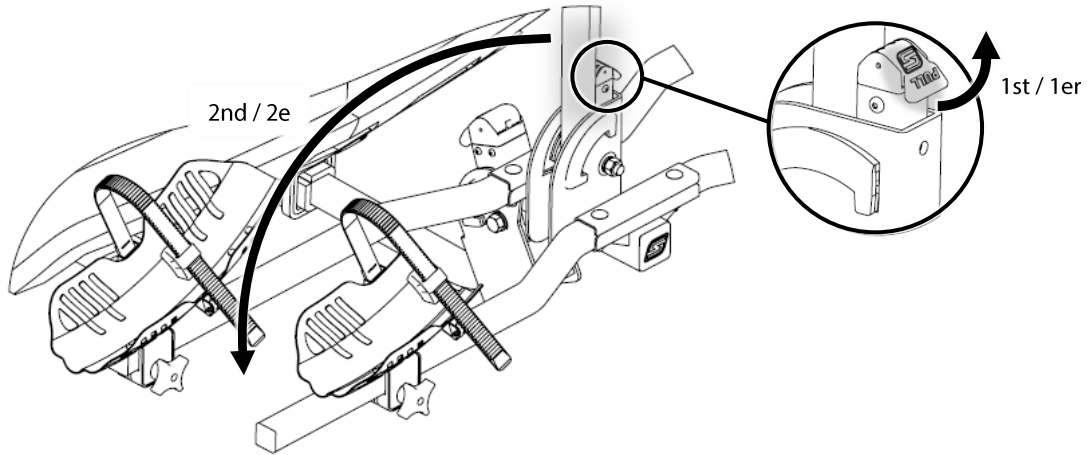

2

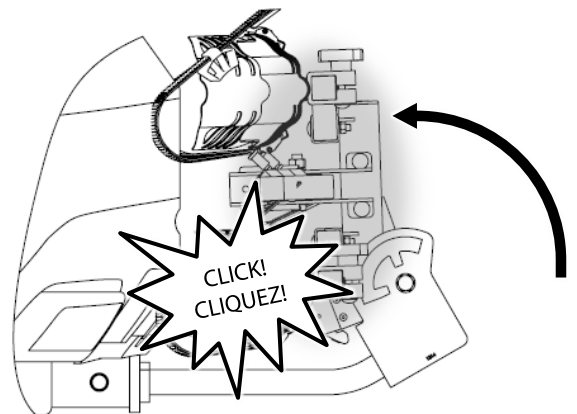
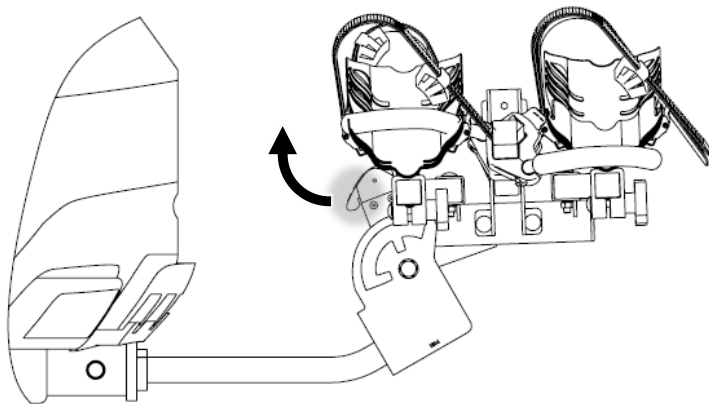

# INSTRUCTIONS

64678 Current Bike Rack / Porte-vélos  
Page 7 | 9



## LOADING / CHARGEMENT

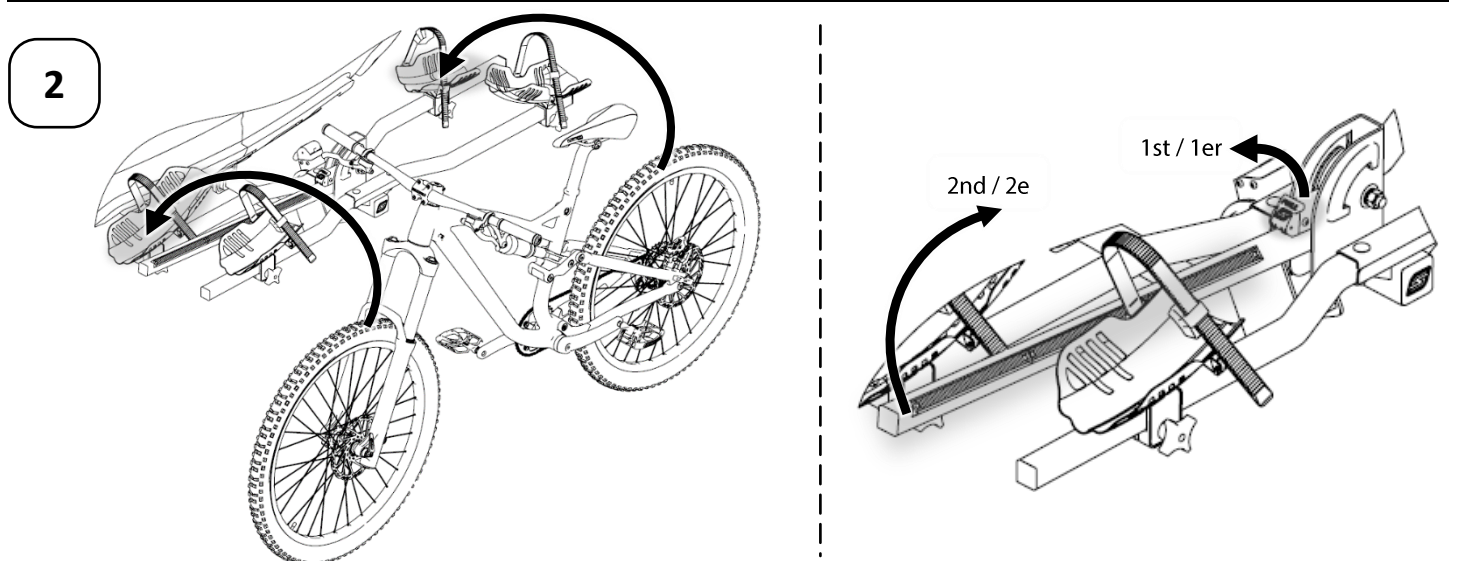
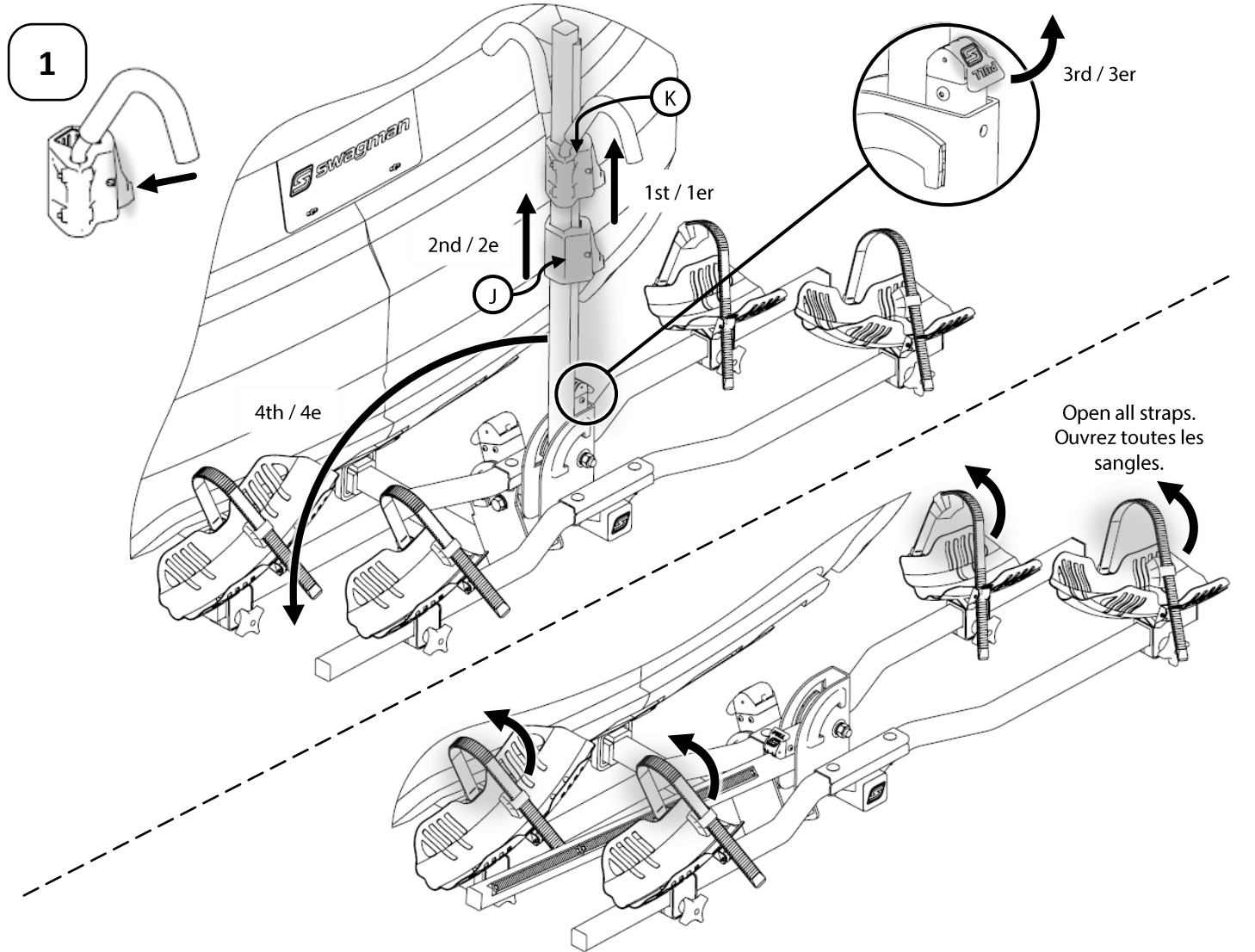

# INSTRUCTIONS

64678 Current Bike Rack / Porte-vélos  
Page 8 | 9

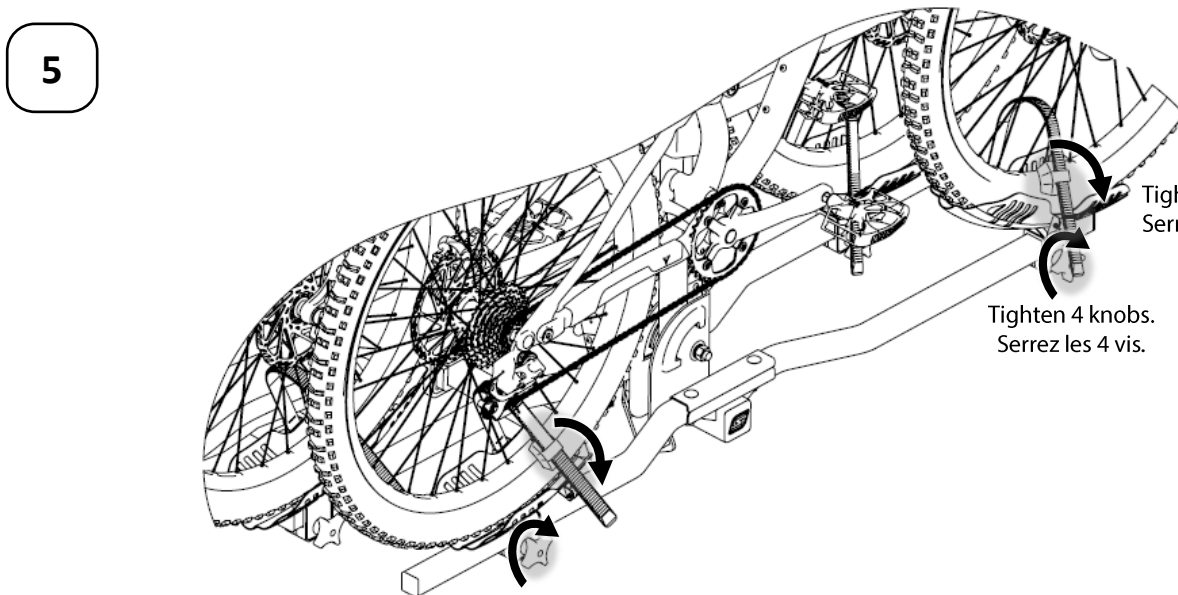
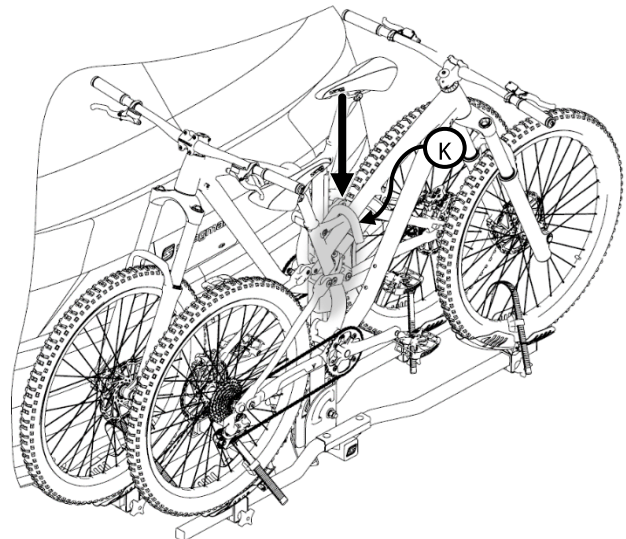
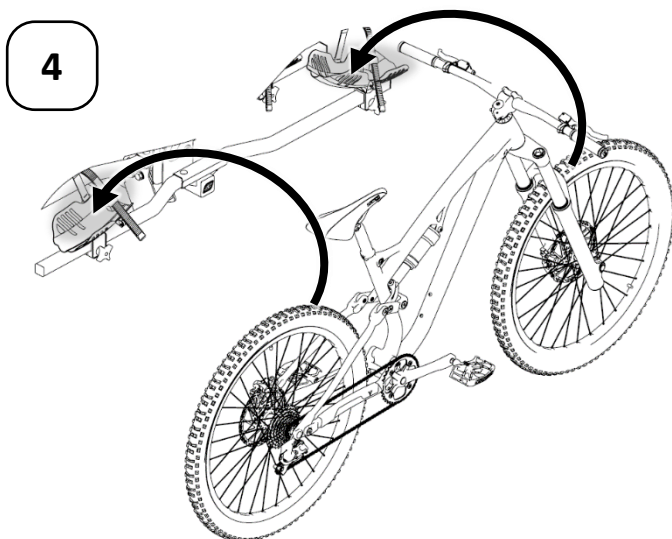
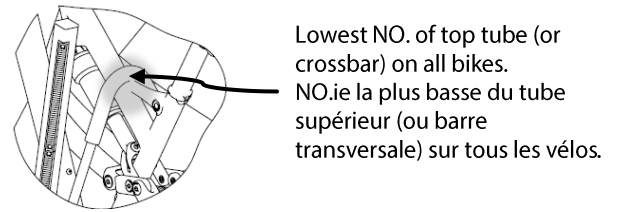
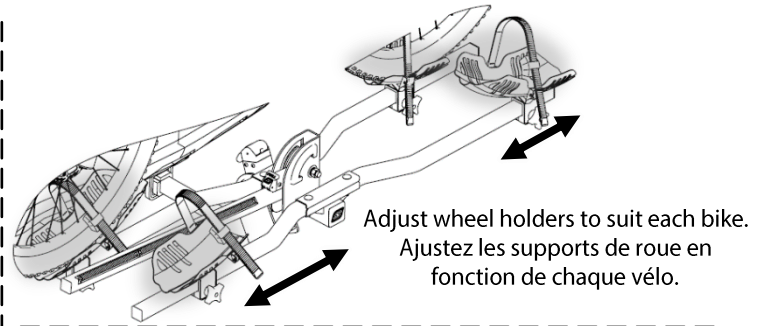
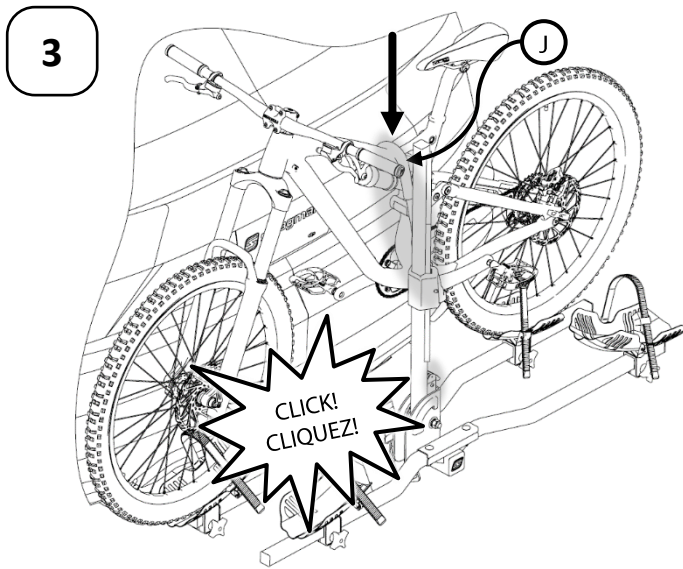



# INSTRUCTIONS

64678 Current Bike Rack / Porte-vélos

Page 9 | 9



## IMPORTANT NOTES

- ▲ This bike rack has a maximum per-bike capacity of 60 lb.
- ▲ This bike rack has a maximum load capacity of 120 lb.
- ▲ This bike rack may not be suitable for use with bikes with carbon fiber frames; check the bicycle manufacturer's recommendations before using this rack.
- ▲ The minimum recommended ground clearance for this rack is 14".
- ▲ This rack is designed for typical use and applications (on paved or smooth gravel roads). Do not use this rack on rough roads or where the rack (and its load) will be subject to significant or constant jarring or shock. Do not use this rack on any vehicle with very stiff springs that will directly transfer the shock to the rack.
- ▲ Properly fitting and installing this carrier to your vehicle is critical and is not the manufacturer's responsibility.
- ▲ Improper use of this product may result in damage to your rack, your vehicle, your load, or even other vehicles colliding with, or trying to avoid, a fallen load and/or rack.
- ▲ Do not use with hitch extender. Hitch extenders amplify force to the rack and its load.
- ▲ It is the purchaser's responsibility to ensure the load created by a rack and load does not exceed the maximum rating on the hitch or bumper.
- ▲ Keep the product indoors when not in use to protect the powder coating, which prevents rust.
- ▲ Add padding to any area of the load that may touch the vehicle to prevent damage to your load and/or vehicle.
- ▲ Racks loaded with large and/or tall accessories (such as a child carrying seat) will greatly increase the wind resistance and pressure on the rack and all vehicle mounting points. Reducing vehicle speed will reduce the chance of problems occurring because of this situation.
- ▲ Keep plastics, rubber, carbon fiber, and other heat-sensitive materials at least 6" away from the vehicle's exhaust pipes. The high-temperature exhaust exiting the exhaust pipes can melt or damage these materials.
- ▲ Keep the bike rack away from the direct exhaust flow.
- ▲ Please call your nearest Swagman authorized retailer or Swagman Customer Service if you have any questions about the compatibility, fitting, or use of this rack.

## NOTES IMPORTANTES

- ▲ Ce porte-vélos à une capacité maximale par vélo de 60 livres.
- ▲ Ce porte-vélos à une capacité de charge maximale de 120 livres.
- ▲ Ce porte-vélos peut ne pas convenir à une utilisation pour des vélos avec des cadres en fibre de carbone; Vérifiez les recommandations du fabricant du vélo avant d'utiliser ce porte-vélos.
- ▲ La garde au sol minimale recommandée pour ce porte-bagages est de 14".
- ▲ Ce support est conçu pour une utilisation et des applications typiques (sur des routes pavées ou en gravier lisse). N'utilisez pas ce support sur des routes accidentées ou là où le support (et sa charge) sera soumis à des secousses ou des chocs importants ou constants. N'utilisez pas ce porte-bagages sur un véhicule avec des ressorts très rigides qui transféreront directement les impacts sur le porte-bagages.
- ▲ Le montage et l'installation appropriés de ce support sur votre véhicule sont essentiels et ne relèvent pas de la responsabilité du fabricant.
- ▲ Une mauvaise utilisation de ce produit peut endommager votre porte-bagages, votre véhicule, votre chargement ou même d'autres véhicules qui heurtent ou tentent d'éviter une charge et/ou un porte-bagages tombé.
- ▲ Ne pas utiliser avec une rallonge d'attelage. Les rallonges d'attelage amplifient la force sur le rack et sa charge.
- ▲ Il est de la responsabilité de l'acheteur de s'assurer que la charge créée par un support et une charge ne dépasse pas la valeur nominale maximale sur l'attelage ou le pare-chocs.
- ▲ Gardez le produit à l'intérieur lorsqu'il n'est pas utilisé pour protéger le revêtement anirouille, ce qui l'empêchera de rouiller.
- ▲ Ajoutez du rembourrage à toute zone de la charge susceptible de toucher le véhicule pour éviter d'endommager votre charge et/ou votre véhicule.
- ▲ Les porte-bagages chargés d'accessoires grands et/ou hauts (comme un siège pour enfant) augmenteront considérablement la résistance au vent et la pression sur le porte-bagages et sur tous les points de montage du véhicule. Réduire la vitesse du véhicule réduira les risques de problèmes liés à cette situation.
- ▲ Gardez les plastiques, le caoutchouc, la fibre de carbone et les autres matériaux sensibles à la chaleur à au moins 6" des tuyaux d'échappement du véhicule. L'échappement à haute température sortant des tuyaux d'échappement peut fondre ou endommager ces matériaux.
- ▲ Éloignez le porte-vélos du flux d'échappement direct.
- ▲ Veuillez appeler votre revendeur agréé Swagman le plus proche ou le service clientèle Swagman si vous avez des questions sur la compatibilité, l'installation ou l'utilisation de ce rack.

 **ATTN: STATE OF CALIFORNIA CONSUMERS**  
WARNING: Cancer and Reproductive Harm • [www.P65Warnings.ca.gov](http://www.P65Warnings.ca.gov)