

## Pioneer Prime Diesel-Driven Centrifugal Pump Trailer Package

# PP64S17L71-1206F-E70TTA



### PUMP SPECIFICATIONS

Size	6" x 4" (150 x 100 mm)
Impeller Diameter	17" (432 mm)
Max Flow	2,850 gpm (600 m <sup>3</sup> /h)
Max Head	470 feet (143 meters)
Solids Size	3" (76 mm)
Max. Operating Temp.	200 °F (93 °C)
Max. Operating Press.	260 psi (1800 kPa)

### ENGINE SPECIFICATIONS

FT4 Engine Type	Perkins 1206F-E70TTA
Displacement	428 cu. in. (7 l)
Fuel Consumption	14.3 gph (54.2 l/h) @ 1800 rpm
Continuous HP	242hp (180kW) @ 1800rpm
Peak HP Rating	301 HP (225 kW)
FT4 Specifics (Def or No Def, DOC, SCR, etc.)	DOC/ DPF, SCR
Safety Shut-Down Switches	Low oil press., high temp., v-belt failure
Instrument Panel	Oil pressure gauge, ampmeter, hourmeter, tachometer

### PIONEER PRIME PRIMING SYSTEM

Priming System	Mechanically driven diaphragm-style vacuum pump
Air Removal Cap.	50 cfm (.02 cms)
Priming Chamber	Positive sealing air separation w/stainless steel components
Discharge Check Valve	Swing style; ductile iron w/nitrile disc
Run Dry System	Oil-lubricated mech. seal allows pump to run completely dry without damage

### FEATURES AND BENEFITS

- Indefinite run-dry capability
- Extreme flow technology
- Environmentally safe priming system: Pioneer Prime
- Auto-start controls
- Skid options available

### OPTIONS AND ACCESSORIES

Parts Kits No.	Mechanical Seal Kit: 372000111   Bearing Frame Kit: 373000112
Instrument Compatibility	Transducer
Telemetry Ready	Options Available

### PACKAGE SPECIFICATIONS

Fuel Capacity	175 gal (795 L)
Control Panel	LOFA CP750
Operating Speed (Min. / Max.)	1,200 / 2,100 rpm
Instrument Compatibility	High/low level floats
Trailer Brakes	Electric
Optional Adders	Surge brakes, corner jacks, tongue-mounted tool box, wheel chocks, exterior lighting, trickle chargers - solar or 120VAC

### MATERIALS OF CONSTRUCTION

Material	Standard Construction
Impeller	CA6NM Stainless Steel
Shaft	17-4 PH Stainless Steel
Wear Ring	ASTM A48 Class 40 Gray Iron
Suction Cover	Ductile Iron ASTM A536 65-45-12
Volute	Ductile Iron ASTM A536 65-45-12
Brac-Plate/Bracket	Ductile Iron ASTM A536 65-45-12
Mechanical Seal	Silicon Carbide rotating and Tungsten Carbide stationary

## MECHANICAL DIMENSIONS

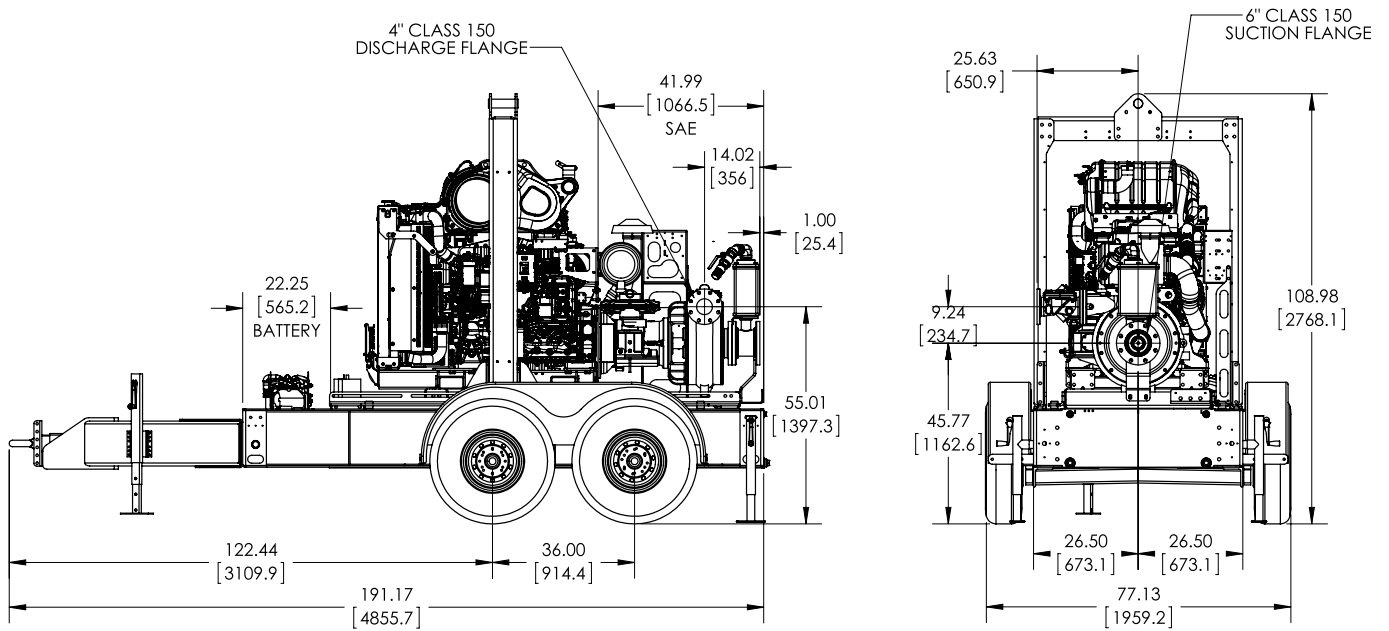

## PERFORMANCE CURVE

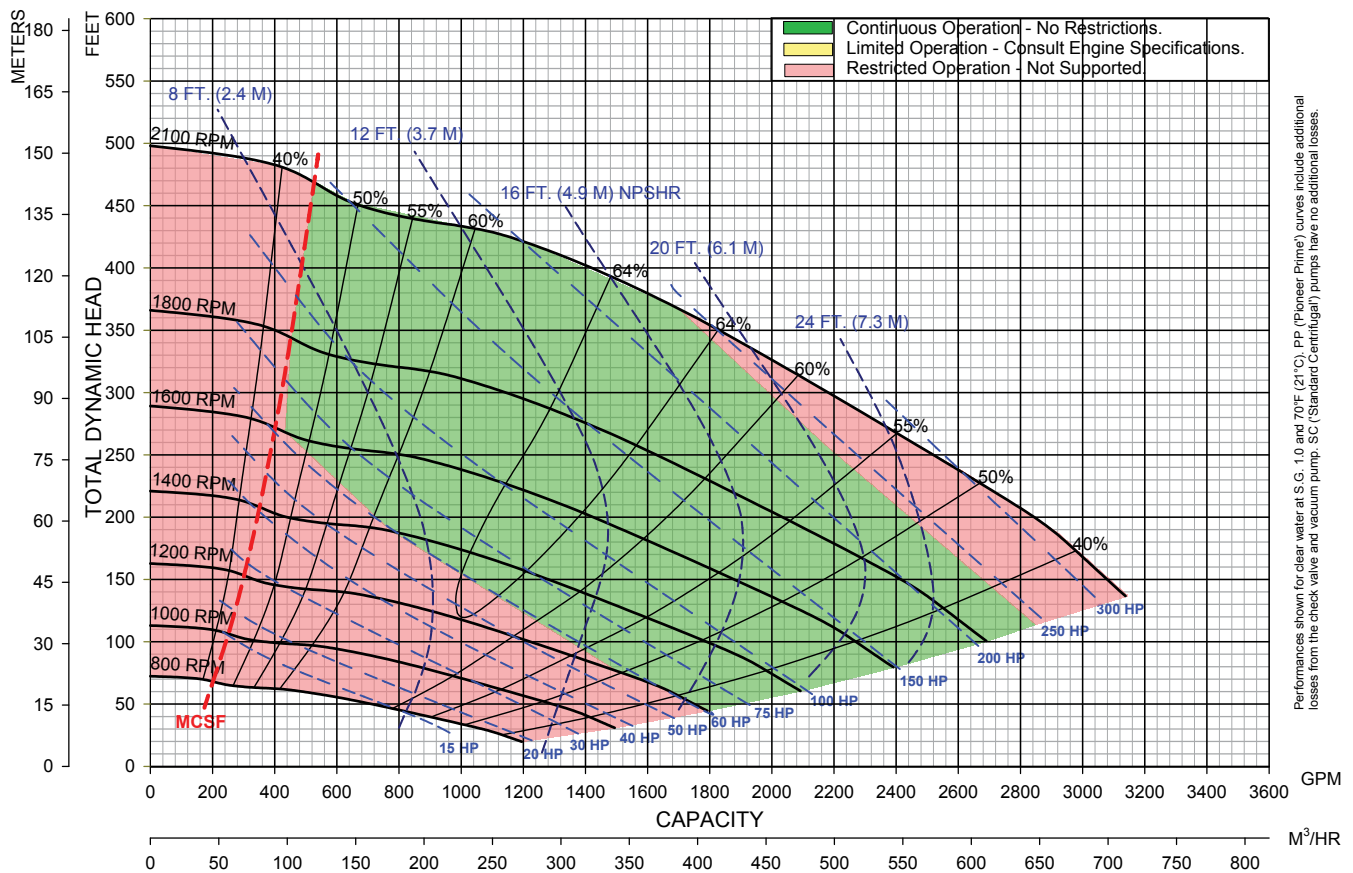

Performances shown for clear water at S.G. 1.0 and 70°F (21°C). PP (Pioneer Prime) curves include additional losses from the check valve and vacuum pump. SC (Standard Centrifugal) pumps have no additional losses.