

## Pioneer Prime Diesel-Driven Centrifugal Pump Trailer Package

# PP66V12L72-TD2.9L4



### PUMP SPECIFICATIONS

Size	6" x 6" (150 x 150 mm)
Impeller Diameter	10.24" (260 mm)
Max Flow	2,150 gpm (488 m <sup>3</sup> /h)
Max Head	120 feet (37 meters)
Solids Size	4.92" (125 mm)
Max. Operating Temp.	200 °F (93 °C)
Max. Operating Press.	260 psi (1800 kPa)

### ENGINE SPECIFICATIONS

FT4 Engine Type	Deutz TD2.9L, 4-Cylinder Diesel
Displacement	177 cu. in. (2.9 l)
Fuel Consumption	1.95 gph (7.38 l/h) @ 1800 rpm
Continuous HP	58 HP (43 kW) @ 1800 rpm
Peak HP Rating	75 HP (55 kW)
FT4 Specifics (Def or No Def, DOC, SCR, etc.)	DVERT <sup>®</sup> oxidation catalyst
Safety Shut-Down Switches	Low oil press., high temp., v-belt failure
Instrument Panel	Oil pressure gauge, ampmeter, hourmeter, tachometer

### PIONEER PRIME PRIMING SYSTEM

Priming System	Mechanically driven diaphragm-style vacuum pump
Air Removal Cap.	50 cfm (.02 cms)
Priming Chamber	Heavy-duty chamber w/no blow-by and stainless steel components
Discharge Check Valve	Elbow ball valve style w/cast iron body avoids clogs from passed-through solids
Run Dry System	Oil-lubricated mech. seal allows pump to run completely dry without damage

### FEATURES AND BENEFITS

- Indefinite run-dry capability
- Extreme flow technology
- Environmentally safe priming system: Pioneer Prime
- Auto-start controls
- Skid options available

### OPTIONS AND ACCESSORIES

Parts Kits No.	N/A
Instrument Compatibility	Transducer
Telemetry Ready	Options Available

### PACKAGE SPECIFICATIONS

Fuel Capacity	75 gal (284 L)
Control Panel	LOFA CP750
Operating Speed (Min. / Max.)	1,000 / 2,100 rpm
Instrument Compatibility	High/low level floats
Trailer Brakes	Electric
Optional Adders	Surge brakes, corner jacks, tongue-mounted tool box, wheel chocks, exterior lighting, solar or 120VAC trickle charger

### MATERIALS OF CONSTRUCTION

Material	Standard Construction
Impeller	Ductile Iron 65-45-12
Shaft	17-4 PH Stainless Steel
Volute	Ductile Iron 65-45-12
Brac-Plate/Bracket	ASTM A48 Class 30/35 Cast Iron
Mechanical Seal	Silicon Carbide rotating and Tungsten Carbide stationary

## MECHANICAL DIMENSIONS

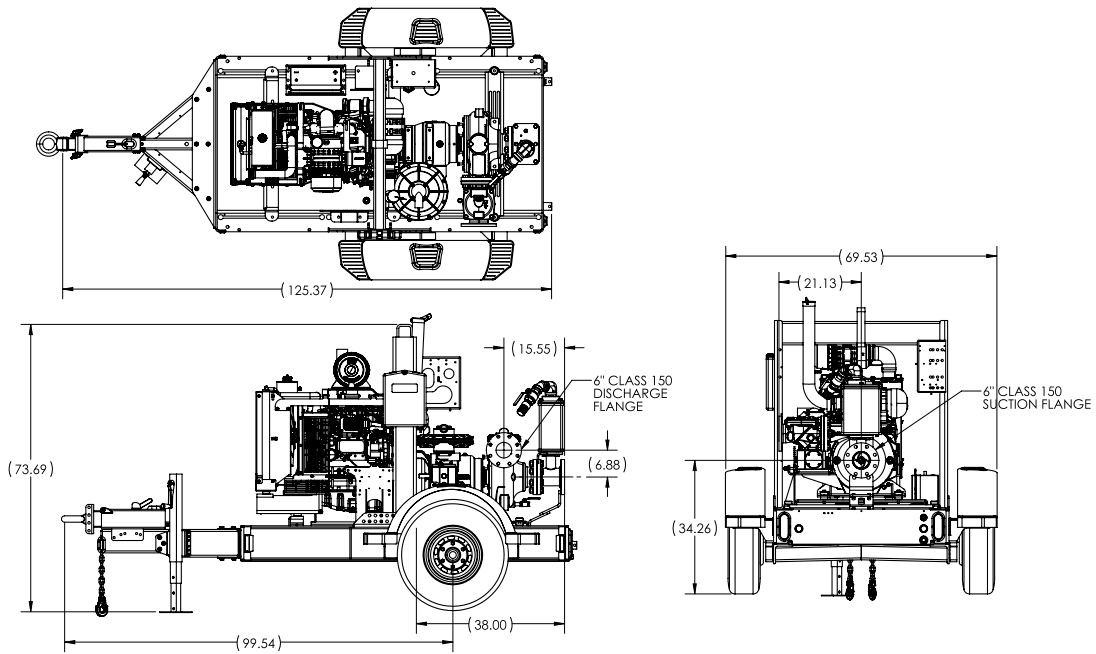

## PERFORMANCE CURVE

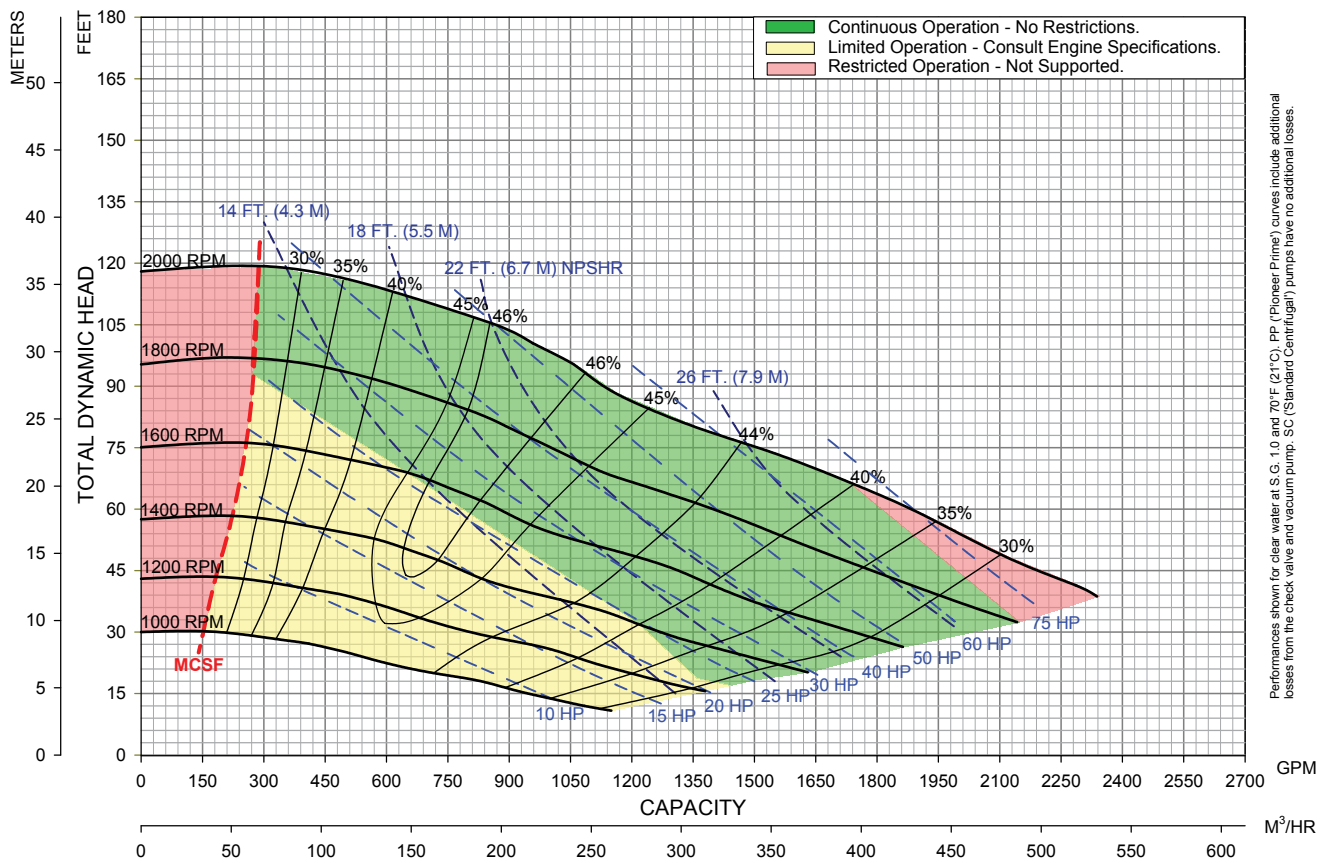

Performances shown for clear water at S.G. 1.0 and 70°F (21°C). PP (Pioneer Prime®) curves include additional losses from the check valve and vacuum pump. SC (Standard Centrifugal) pumps have no additional losses.