

Pioneer Prime Diesel-Driven Centrifugal Pump Trailer Package

PP64S12L71-4045TFC03

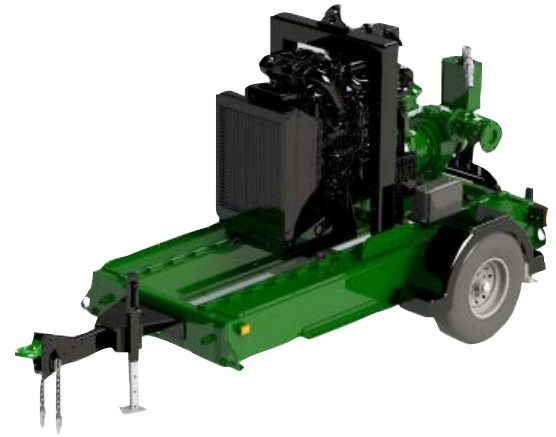

PUMP SPECIFICATIONS

Size	6" x 4" (150 x 100 mm)
Impeller Diameter	12" (305 mm)
Max Flow	1,920 gpm (429 m ³ /h)
Max Head	265 feet (80 meters)
Solids Size	3" (76 mm)
Max. Operating Temp.	200 °F (93 °C)
Max. Operating Press.	260 psi (1800 kPa)

ENGINE SPECIFICATIONS

FT4 Engine Type	John Deere 4045TFC03
Displacement	275 cu. in. (4.5 l)
Fuel Consumption	3.59 gph (13.6 l/h) @ 1800 rpm
Continuous HP	72 HP (53 kW) @ 1800 rpm
Peak HP Rating	74 HP (55 kW)
FT4 Specifics (Def or No Def, DOC, SCR, etc.)	DOC/DPF, SCR
Safety Shut-Down Switches	Low oil press., high temp., v-belt failure
Instrument Panel	Oil pressure gauge, ampmeter, hourmeter, tachometer

PIONEER PRIME PRIMING SYSTEM

Priming System	Mechanically driven diaphragm-style vacuum pump
Air Removal Cap.	50 cfm (.02 cms)
Priming Chamber	Positive sealing air separation w/stainless steel components
Discharge Check Valve	Swing style; ductile iron w/nitrile disc
Run Dry System	Oil-lubricated mech. seal allows pump to run completely dry without damage

FEATURES AND BENEFITS

- Indefinite run-dry capability
- Extreme flow technology
- Environmentally safe priming system: Pioneer Prime
- Auto-start controls
- Skid options available

OPTIONS AND ACCESSORIES

Parts Kits No.	Mechanical Seal Kit: 372000154 Bearing Frame Kit: 373000146
Instrument Compatibility	Transducer
Telemetry Ready	Options Available

PACKAGE SPECIFICATIONS

Fuel Capacity	135 gal (511 L)
Control Panel	LOFA CP750
Operating Speed (Min. / Max.)	1,000 / 2,200 rpm
Instrument Compatibility	High/low level floats
Trailer Brakes	Electric
Optional Adders	Surge brakes, corner jacks, tongue-mounted tool box, wheel chocks, exterior lighting, solar or 120VAC trickle charger

MATERIALS OF CONSTRUCTION

Material	Standard Construction
Impeller	CA6NM Stainless Steel
Shaft	17-4 PH Stainless Steel
Wear Ring	ASTM A48 Class 40 Gray Iron
Suction Cover	Ductile Iron ASTM A536 65-45-12
Volute	Ductile Iron ASTM A536 65-45-12
Brac-Plate/Bracket	Ductile Iron ASTM A536 65-45-12
Mechanical Seal	Silicon Carbide rotating and Tungsten Carbide stationary

MECHANICAL DIMENSIONS

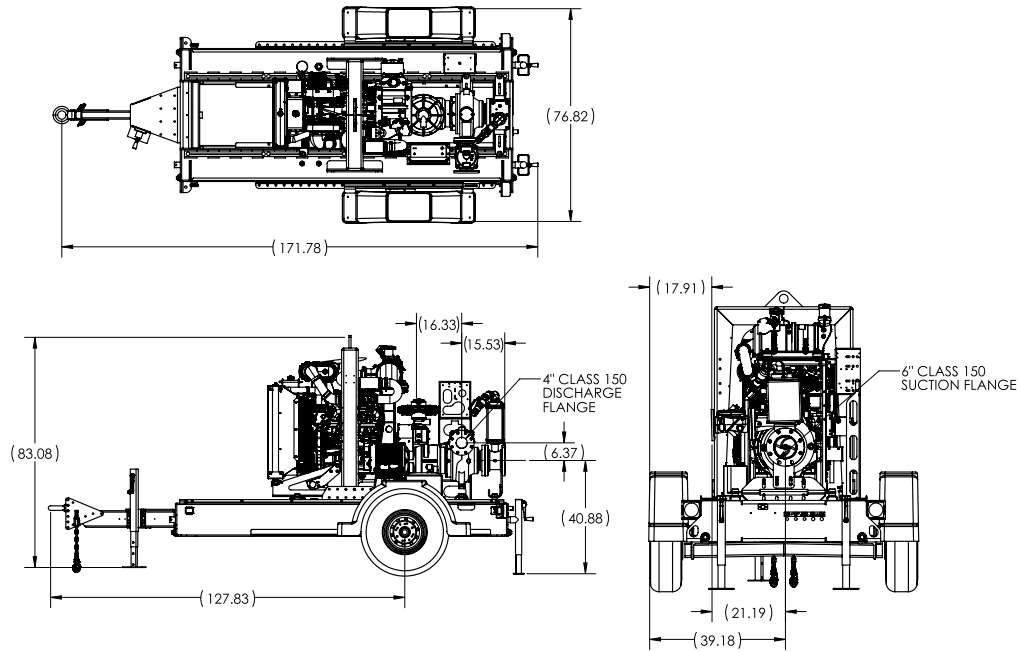

PERFORMANCE CURVE

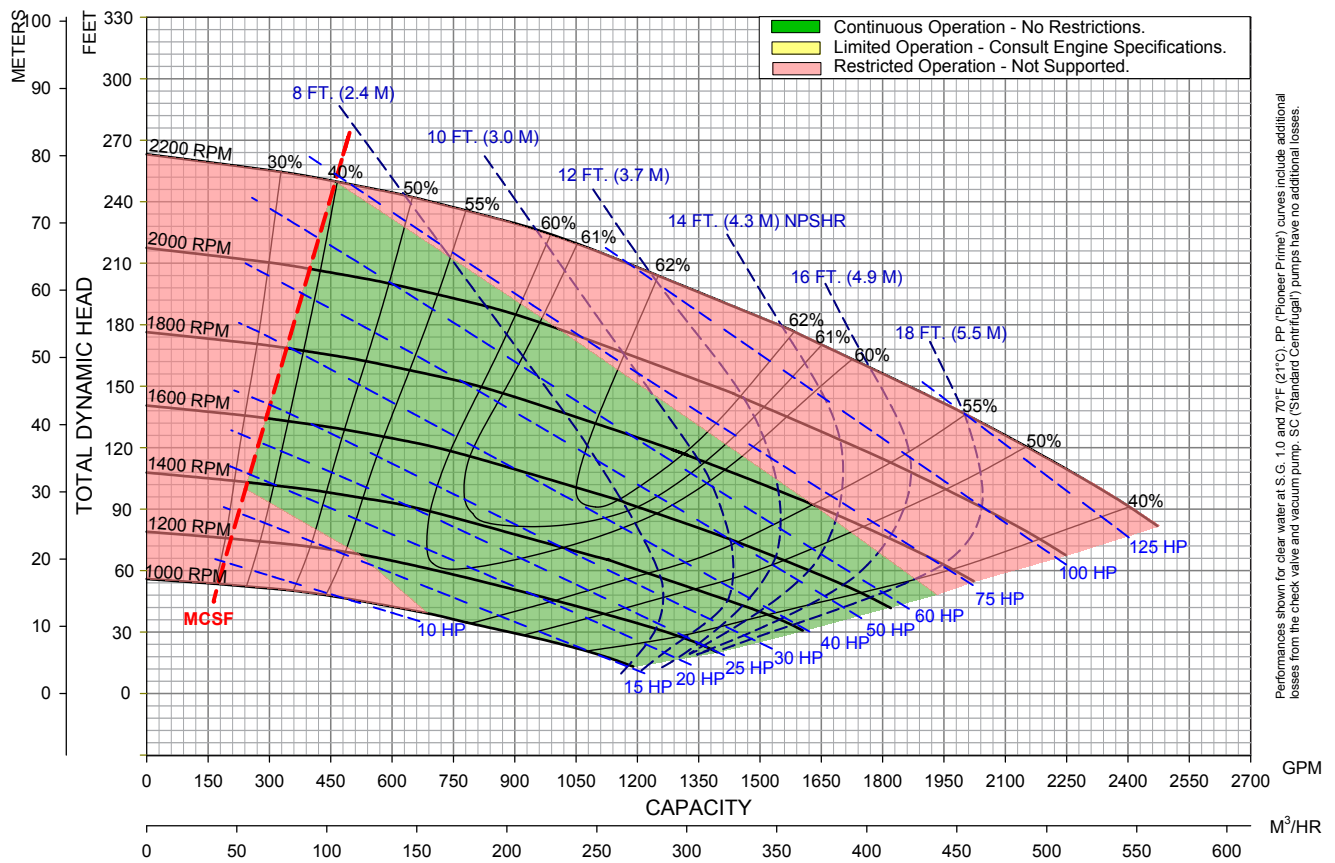

Performances shown for clear water at S.G. 1.0 and 70°F (21°C). PP (Pioneer Prime) curves include additional losses from the check valve and vacuum pump. SC (Standard Centrifugal) pumps have no additional losses.