

Pioneer Prime Diesel-Driven Centrifugal Pump Trailer Package

PP66S12L71-TD2.9L4



PUMP SPECIFICATIONS

Size	6" x 6" (150 x 150 mm)
Impeller Diameter	11" (279 mm)
Max Flow	2,825 gpm (642 m ³ /h)
Max Head	195 feet (59 meters)
Solids Size	3" (76 mm)
Max. Operating Temp.	200 °F (93 °C)
Max. Operating Press.	260 psi (1800 kPa)

ENGINE SPECIFICATIONS

FT4 Engine Type	Deutz TD2.9L, 4-Cylinder Diesel
Displacement	177 cu. in. (2.9 l)
Fuel Consumption	3.07 gph (7.83 l/h) @ 1800 rpm
Continuous HP	58 HP (43 kW) @ 1800 rpm
Peak HP Rating	75 HP (55 kW)
FT4 Specifics (Def or No Def, DOC, SCR, etc.)	DOC
Safety Shut-Down Switches	Low oil press., high temp., v-belt failure
Instrument Panel	Oil pressure gauge, ampmeter, hourmeter, tachometer

PIONEER PRIME PRIMING SYSTEM

Priming System	Mechanically driven diaphragm-style vacuum pump
Air Removal Cap.	50 cfm (.02 cms)
Priming Chamber	Positive sealing air separation w/stainless steel components
Discharge Check Valve	Swing style; ductile iron w/nitrile disc
Run Dry System	Oil-lubricated mech. seal allows pump to run completely dry without damage

FEATURES AND BENEFITS

- Indefinite run-dry capability
- Extreme flow technology
- Environmentally safe priming system: Pioneer Prime
- Auto-start controls
- Skid options available

OPTIONS AND ACCESSORIES

Parts Kits No.	Mechanical Seal Kit: 372000101 Bearing Frame Kit: 37300100
Instrument Compatibility	Transducer
Telemetry Ready	Options Available

PACKAGE SPECIFICATIONS

Fuel Capacity	75 gal (284 L)
Control Panel	LOFA CP750
Operating Speed (Min. / Max.)	1,000 / 2,200 rpm
Instrument Compatibility	High/low level floats
Trailer Brakes	Electric
Optional Adders	Surge breaks, corner jacks, tongue-mounted tool box, wheel chocks, exterior lighting, solar or 120VAC trickle charger

MATERIALS OF CONSTRUCTION

Material	Standard Construction
Impeller	CA6NM Stainless Steel
Shaft	17-4 PH Stainless Steel
Wear Ring	ASTM A48 Class 40 Gray Iron
Suction Cover	Ductile Iron ASTM A536 65-45-12
Volute	Ductile Iron ASTM A536 65-45-12
Brac-Plate/Bracket	Ductile Iron ASTM A536 65-45-12
Mechanical Seal	Silicon Carbide rotating and Tungsten Carbide stationary

MECHANICAL DIMENSIONS

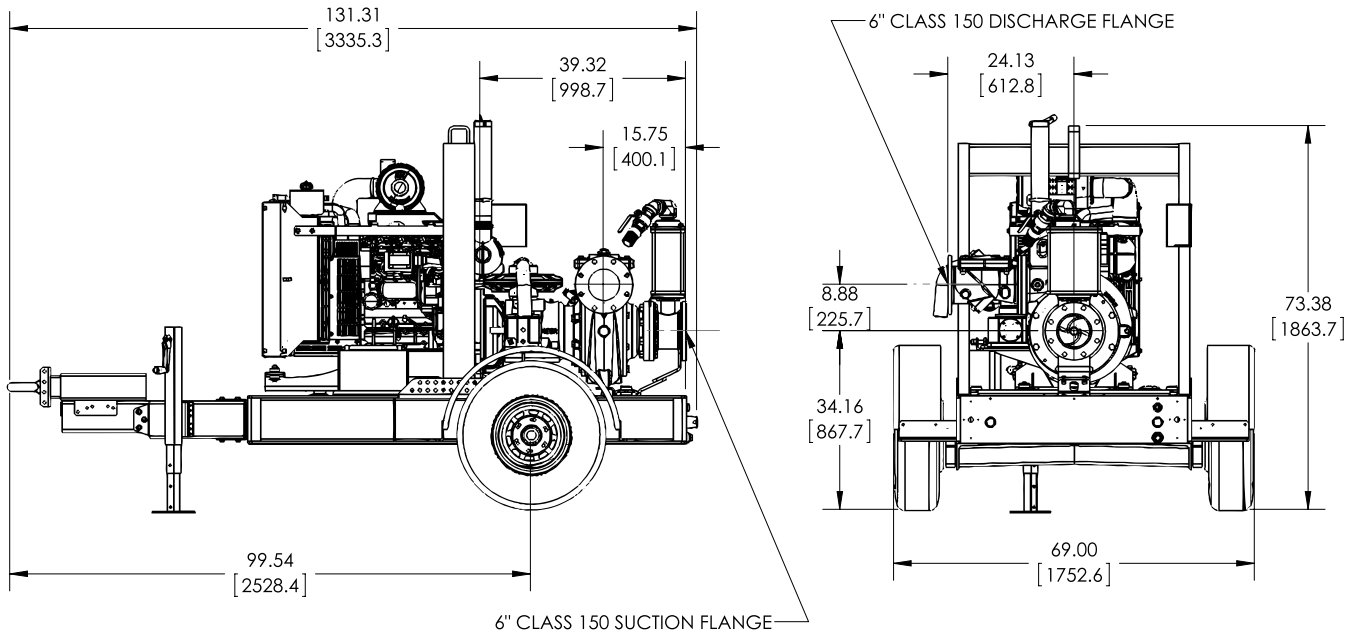

PERFORMANCE CURVE

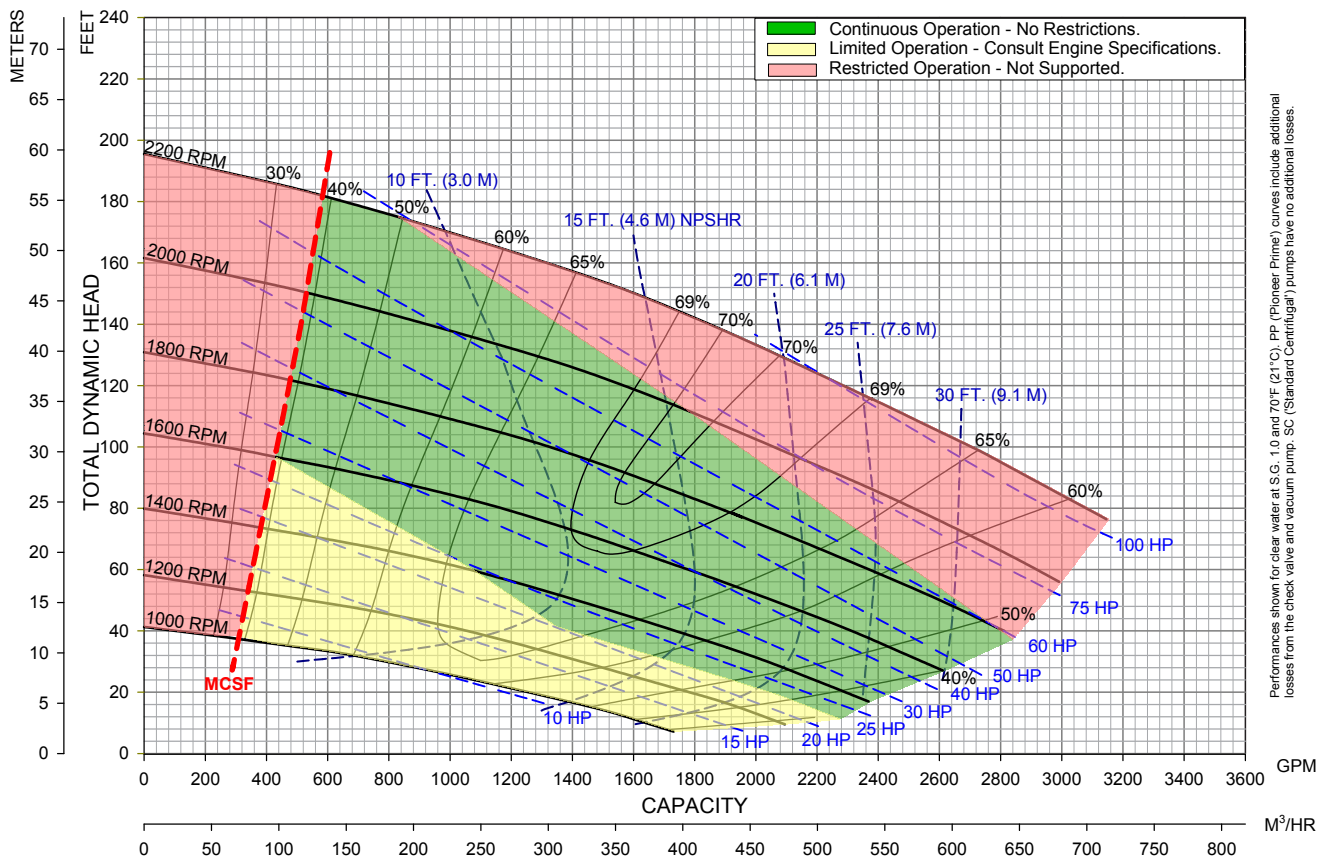

Performances shown for clear water at S.G. 1.0 and 70°F (21°C). PP (Pioneer Prime) curves include additional losses from the check valve and vacuum pump. SC (Standard Centrifugal) pumps have no additional losses.