

Qty. Description

1 **HYDRO MULTI-E 2 CRE 3-4**



Note! Product picture may differ from actual product

Product No.: [99614229](#)

GRUNDFOS Hydro Multi-E booster sets are designed for the transfer and pressure boosting of clean water in waterworks, blocks of flats, hotels, industry, hospitals, schools, etc.

GRUNDFOS Hydro Multi-E booster sets consists of 2 to 3 CR(N)E pumps coupled in parallel and mounted on a common base frame provided with all the necessary fittings.

Hydro Multi-E is mounted on a common base frame made in black painted mild steel.

On the suction side are fitted a suction manifold (AISI 316 or EN 1.4571) and two pressure transmitters which are mounted on an isolating valve.

On the discharge side of the pumps are fitted a non-return valve, an isolating valve, a pressure gauge, two pressure transmitters mounted on an isolating valve, a diaphragm tank and a stainless steel discharge manifold (AISI 316 or EN 1.4571).

The Hydro Multi-E is fitted with an on/off-switch for the supply voltage.

The Hydro Multi-E is designed for maintaining a constant pressure regardless of flow changes and fluctuation.

The internal PI-controller regulates the number of running pumps and the speed of the pumps according to the required flow.

The system can be operated directly on the graphical display of any of the pumps or via Grundfos GO (available as accessory)

Besides the system features:

- 2 Relay outputs
- 2 Digital inputs (one used for external start/stop)
- 2 Digital configurable input/output (one used for external start/stop)
- 3 analogue inputs (one used for discharge pressure and one used for inlet pressure)
- Multi-Master functionality
- 2 Limit exceed functions (one used for dry running protection)
- Set-point influence
- Pipe filling function
- Proportional pressure and High Efficient PM motors

Available communication protocols:

- LON
- PROFIBUS DP
- PROFIBUS IO
- BACnet MS/TP
- BACnet IP
- Modbus RTU
- Modbus TCP

Company name: Parkway Process Solutions
Created by: Parkway Process Solutions
Phone: +61 (0) 390 693 200
Email: solutions@pwnps.com
Date: 11/15/2021

Qty. Description

Ethernet IP
Cellular 3G/4G
GiC/GRM

When delivered, the GRUNDFOS Hydro Multi-E booster set is factory tested and ready for operation.

Liquid:

Pumped liquid: Water
 Liquid temperature range: 5 .. 60 °C
 Selected liquid temperature: 20 °C
 Density: 998.2 kg/m³

Materials:

Pump housing: Cast iron

Installation:

Maximum operating pressure: 10 bar
 Maximum permissible inlet pressure: PN 10 bar
 Flange standard: DIN ISO 7/1
 Manifold inlet: R 2
 Manifold outlet: R 2

Electrical data:

IE Efficiency class: IE5
 Power (P2) main pump: 0.37 kW
 Mains frequency: 50 / 60 Hz
 Rated voltage: 1 x 200-240 V
 Rated current: 4.78 A
 Start. method: electronically
 Enclosure class (IEC 34-5): IP55

Tank:

Volume of pressure tank: 24 l
 Diaphragm tank: Yes

Others:

Net weight: 90 kg
 Gross weight: 119 kg
 Shipping volume: 0.61 m³
 Language: Multi
 Country of origin: SG
 Custom tariff no.: 8413709062

Company name: Parkway Process Solutions
Created by: Parkway Process Solutions
Phone: +61 (0) 390 693 200
Email: solutions@pwnps.com
Date: 11/15/2021

99614229 HYDRO MULTI-E 2 CRE 3-4

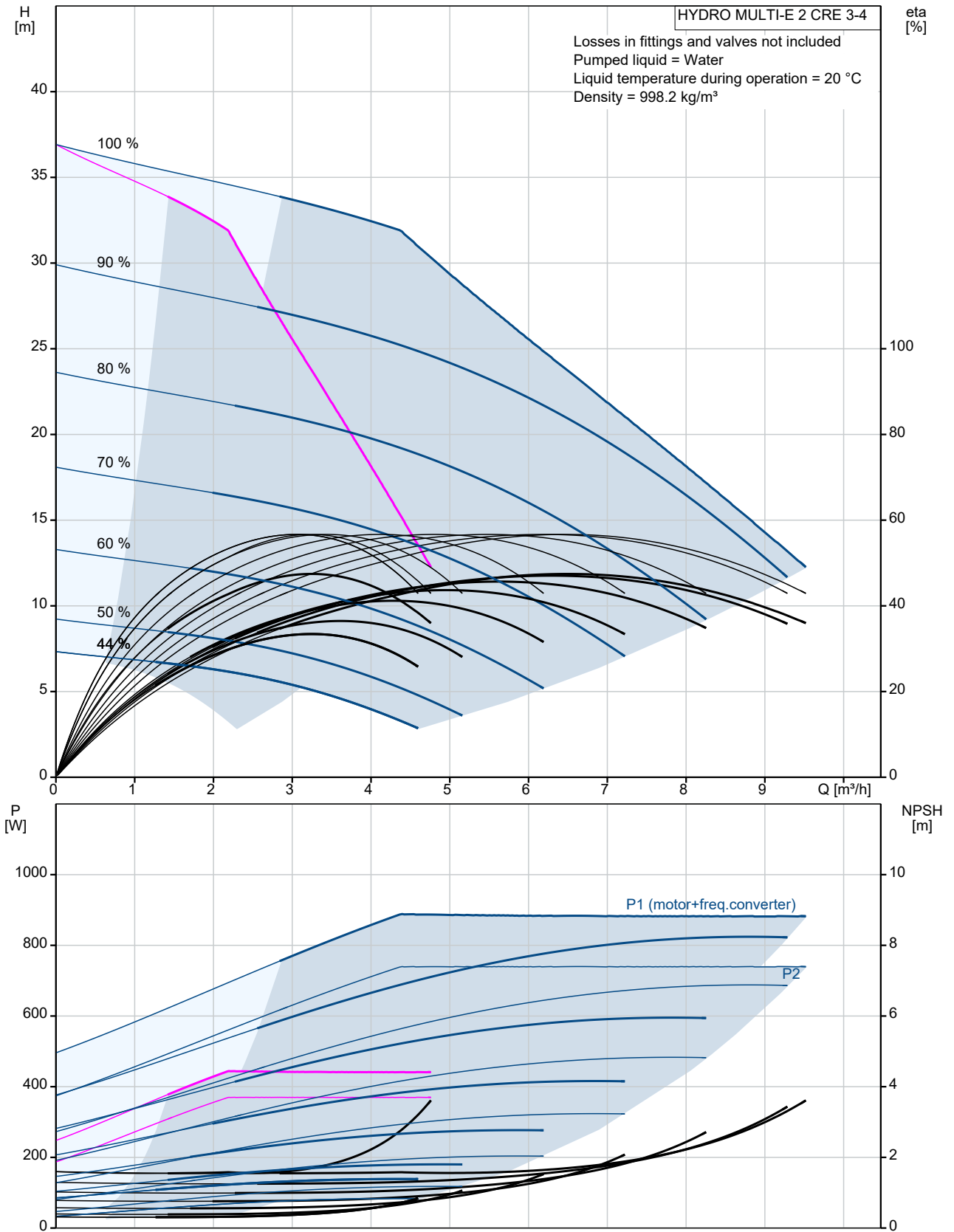

Company name: Parkway Process Solutions
Created by: Parkway Process Solutions
Phone: +61 (0) 390 693 200
Email: solutions@pwnps.com
Date: 11/15/2021

Description	Value
General information:	
Product name:	HYDRO MULTI-E 2 CRE 3-4
Product No:	99614229
EAN number:	5713831933960
Price:	
Technical:	
Max flow:	10.8 m ³ /h
Max flow:	10.8 m ³ /h
Min flow system:	1.3 m ³ /h
Head max:	37 m
Pump name:	CRE 3-4
Number of pumps:	2
Materials:	
Pump housing:	Cast iron
Manifolds:	Stainless steel
Installation:	
Maximum operating pressure:	10 bar
Maximum permissible inlet pressure:	PN 10 bar
Flange standard:	
	DIN ISO 7/1
Manifold inlet:	R 2
Manifold outlet:	R 2
Liquid:	
Pumped liquid:	Water
Liquid temperature range:	5 .. 60 °C
Selected liquid temperature:	20 °C
Density:	998.2 kg/m ³
Electrical data:	
IE Efficiency class:	IE5
Power (P2) main pump:	0.37 kW
Mains frequency:	50 / 60 Hz
Rated voltage:	1 x 200-240 V
Rated current:	4.78 A
Start. method:	electronically
Enclosure class (IEC 34-5):	IP55
Tank:	
Volume of pressure tank:	24 l
Diaphragm tank:	Yes
Others:	
Net weight:	90 kg
Gross weight:	119 kg
Shipping volume:	0.61 m ³
Language:	Multi
Sales region:	Asia
Product range:	I
Country of origin:	SG
Custom tariff no.:	8413709062

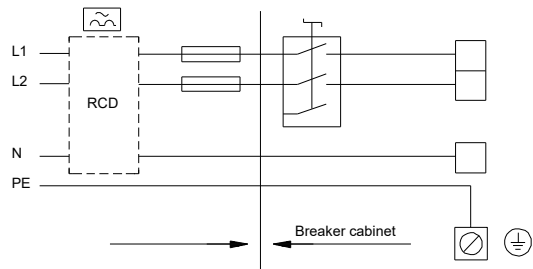
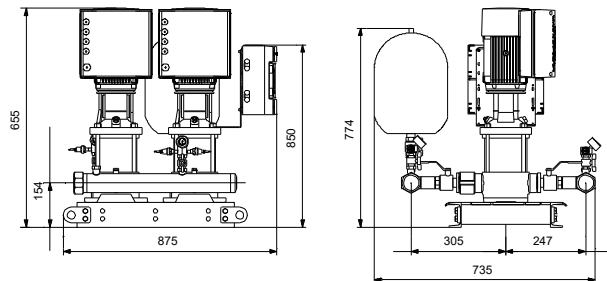
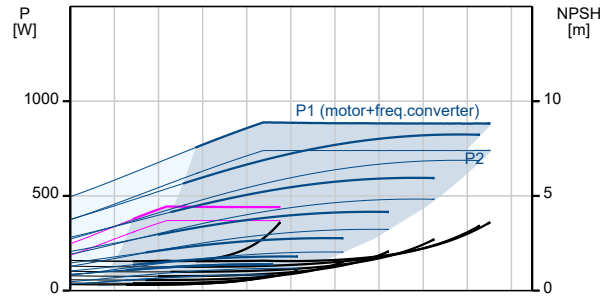
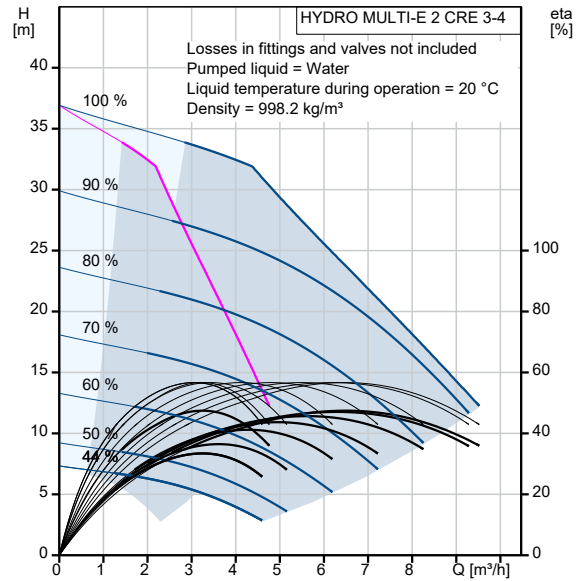

Company name: Parkway Process Solutions
Created by: Parkway Process Solutions
Phone: +61 (0) 390 693 200
Email: solutions@pwnps.com
Date: 11/15/2021

99614229 HYDRO MULTI-E 2 CRE 3-4

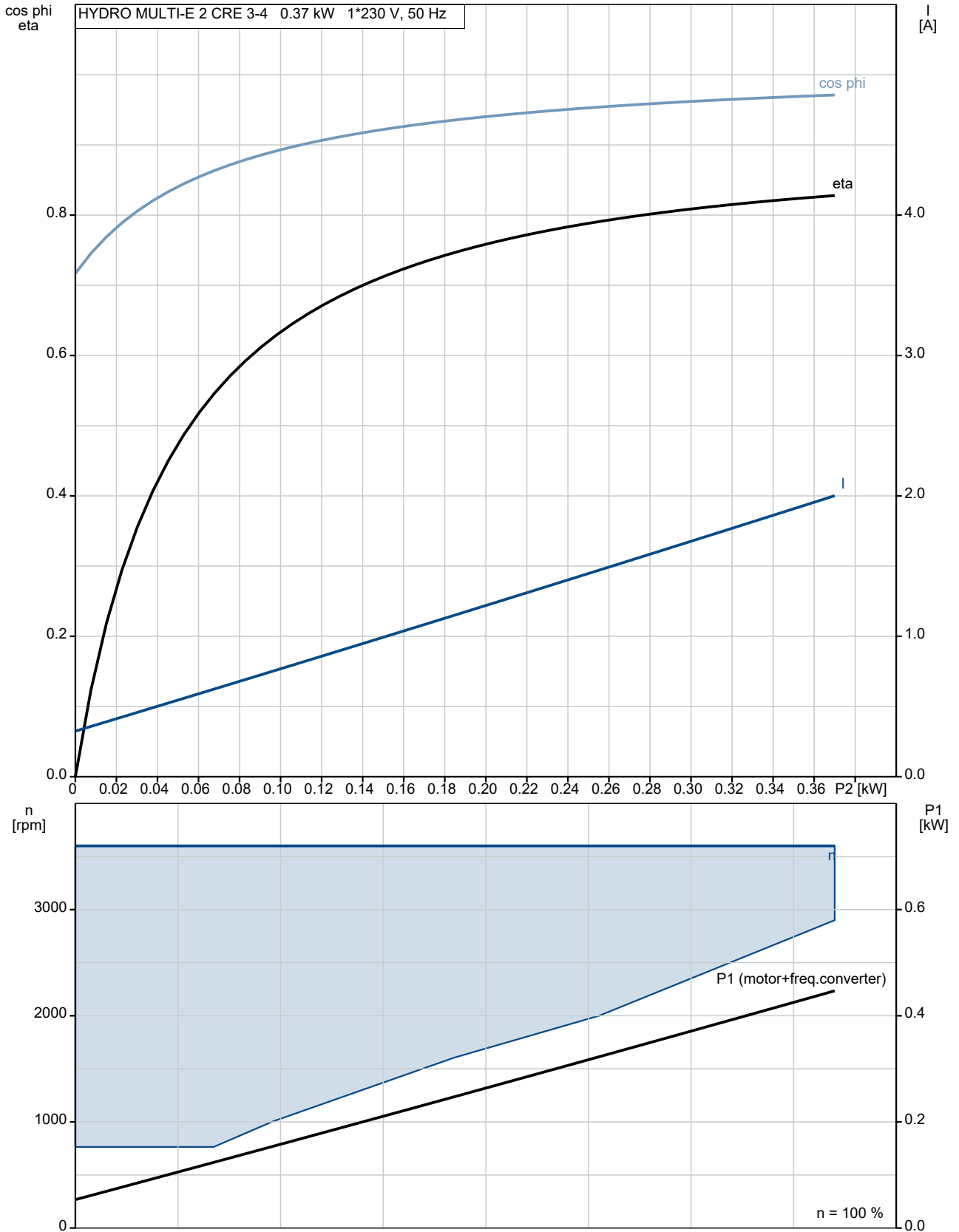

Company name: Parkway Process Solutions
Created by: Parkway Process Solutions
Phone: +61 (0) 390 693 200
Email: solutions@pwnps.com
Date: 11/15/2021

99614229 HYDRO MULTI-E 2 CRE 3-4

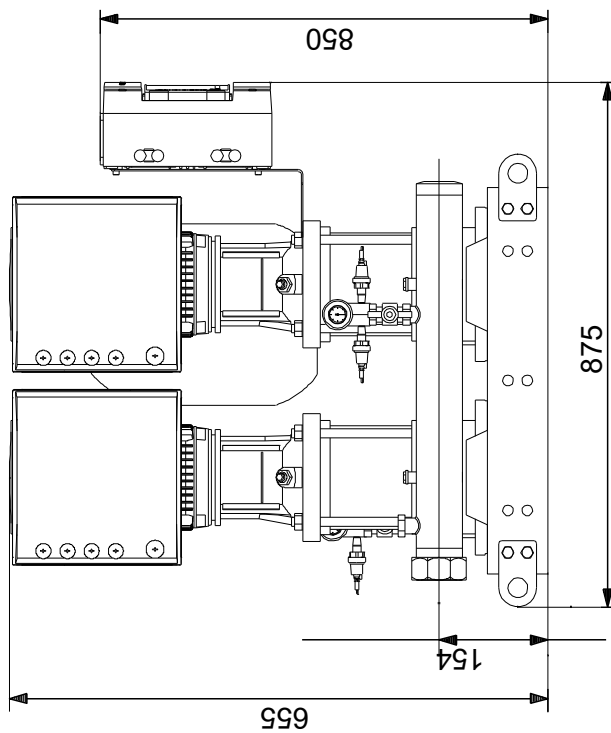
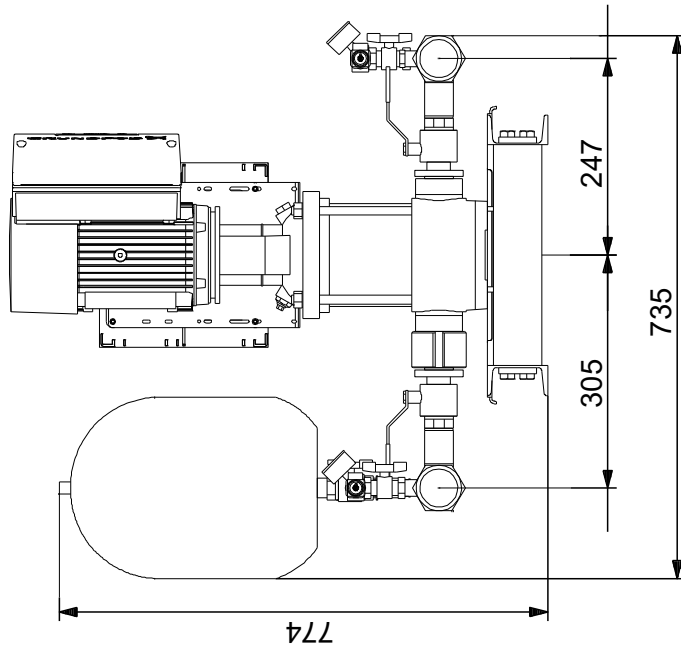

Note! All units are in [mm] unless others are stated.
Disclaimer: This simplified dimensional drawing does not show all details.

Company name: Parkway Process Solutions
Created by: Parkway Process Solutions
Phone: +61 (0) 390 693 200
Email: solutions@pwnps.com
Date: 11/15/2021

99614229 HYDRO MULTI-E 2 CRE 3-4

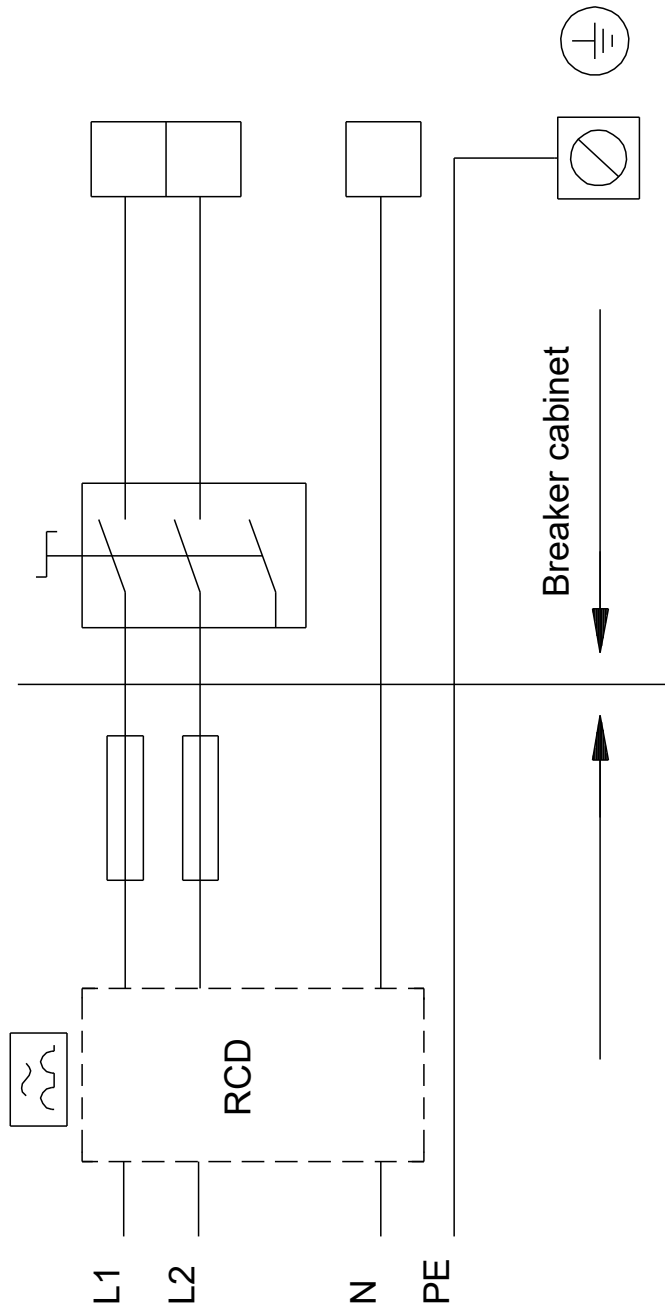

Note! All units are in [mm] unless others are stated.

Company name: Parkway Process Solutions
Created by: Parkway Process Solutions
Phone: +61 (0) 390 693 200
Email: solutions@pwnps.com
Date: 11/15/2021

Order Data:

Product name: HYDRO MULTI-E 2 CRE 3-4
Amount: 1
Product No: 99614229
Price:

Total: Price on request

Company name: Parkway Process Solutions
Created by: Parkway Process Solutions
Phone: +61 (0) 390 693 200
Email: solutions@pwnps.com
Date: 11/15/2021

(TM076325 for project Multi-E Asia Pacific)

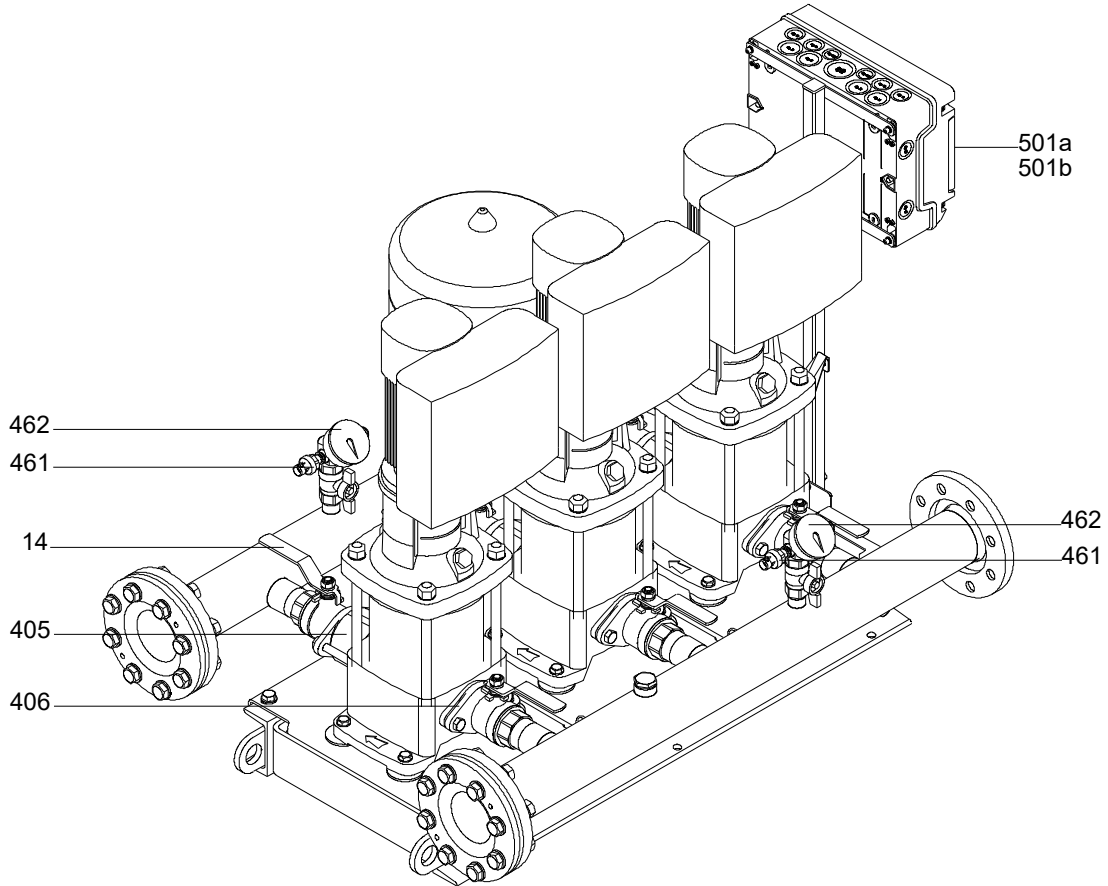

Company name: Parkway Process Solutions
Created by: Parkway Process Solutions
Phone: +61 (0) 390 693 200
Email: solutions@pwnps.com
Date: 11/15/2021

(TM069451 for SMCR standard)

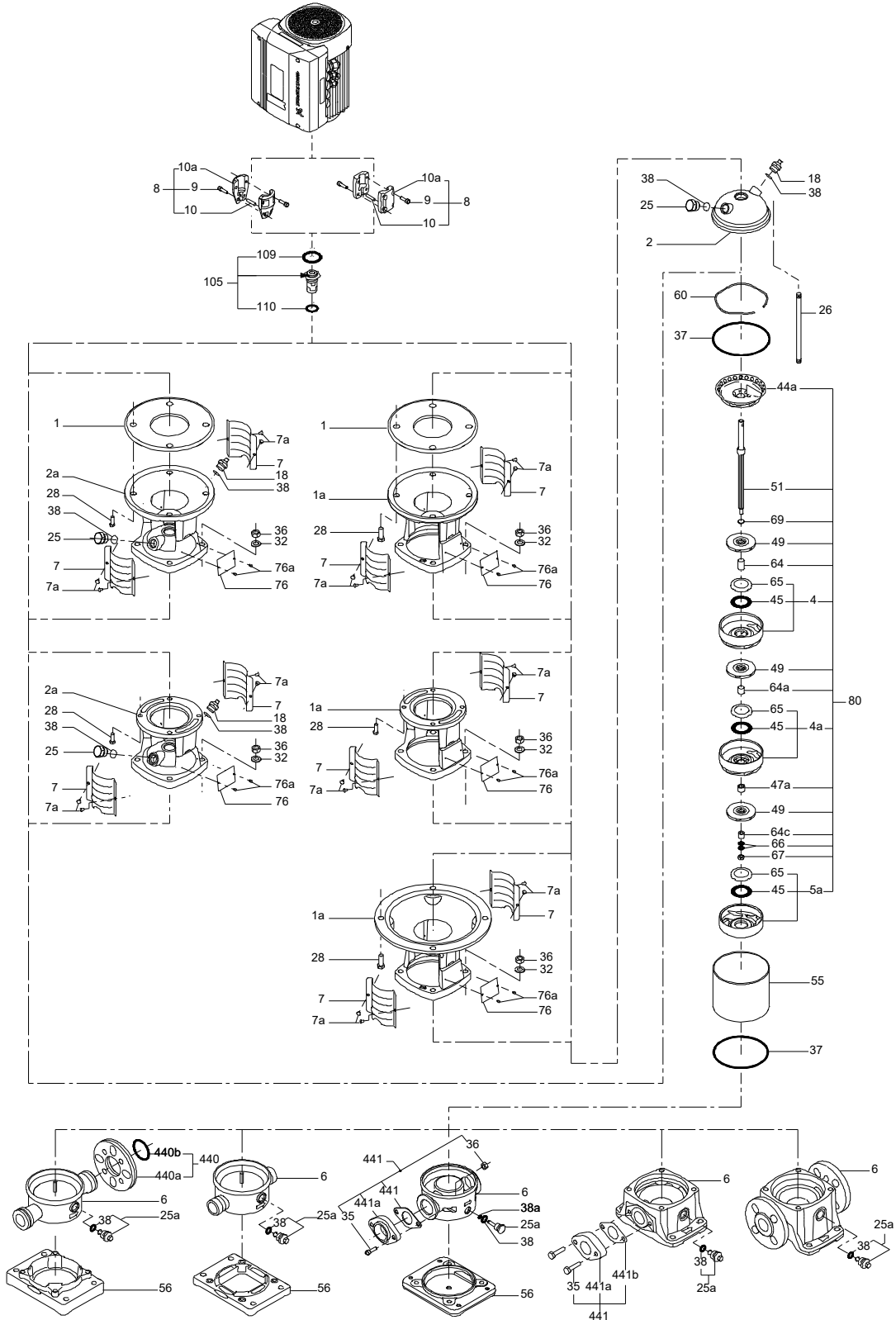

Company name: Parkway Process Solutions
Created by: Parkway Process Solutions
Phone: +61 (0) 390 693 200
Email: solutions@pwnps.com
Date: 11/15/2021

Spare parts HYDRO MULTI-E 2 CRE 3-4, Product No. 99614229
Produced After 1948 (production year and week number)

Pos	Description	Annotation	Classification Data	Part no.	Qty.	Unit
-	Kit, Manometer 0-10 bar			97896856	2	pcs
462	Pressure gauge				1	
-	Kit, Non-return valve			96637443	1	pcs
405	Non-return valve				1	
-	Spare, Cabinet			99876844	1	pcs
501a	Cabinet				1	
-	Spare, Fusebox			99876793	1	pcs
501b	Fusebox				1	
-	Spare, Gasket			99876850	4	pcs
406	Gasket				1	
-	Spare, PressureTr. 0-10 bar			99257835	1	pcs
461	Pressure transducer				1	
-	Spare, PressureTr. 0-6 bar			99257833	1	pcs
461	Pressure transducer				1	
-	Spare, Valve with flange			99876845	2	pcs
14	Valve cpl.				1	
-	Pump				2	pcs
-	Kit, Chamber stack		Bearing type: SILICON CARBIDE	96453531	1	
- 4a	Chamber w. bearing cpl.					
	Vane					
	Intermediate chamber					
	Retainer for bearing					
	Guide vane					
45	Neck ring					
47	Bearing bush					
65	Retainer					
65	Retainer					
- 4	Chamber cpl.					
	Vane					
	Intermediate chamber					
	Plate					
	Guide vane					
45	Neck ring					
65	Retainer					
65	Retainer					
- 5a	Chamber cpl.					
	Vane					
	Intermediate chamber					
45	Neck ring					
65	Retainer					
65	Retainer					
- 44a	Guide vane cpl.					
	Plate					
	Guide vane					
50	Top plate					
47a	Bearing ring					
49	Impeller cpl.					
51	Shaft, spline, cpl.					
64d	Spacing pipe		Internal diameter: 12,85			
			Outer diameter: 15,85			
			Length (mm): 4,50			

Company name: Parkway Process Solutions
Created by: Parkway Process Solutions
Phone: +61 (0) 390 693 200
Email: solutions@pwnps.com
Date: 11/15/2021

Pos	Description	Annotation	Classification Data	Part no.	Qty.	Unit
64c	Clamp, splined		Internal diameter: 8,5 Outer diameter: 15			
64a	Spacing pipe					
66	Wedge lock washer					
67	Lock nut		Thread: M8			
-	Kit, Coupling			00415060	1	
9	Hex socket head cap screw		Designation: DIN 912 Length (mm): 20 Thread: M6			
10a	Coupling half					
10	Shaft pin		Diameter: 5 Length (mm): 26			
-	Kit, Coupling guard			96505130	1	
7.a	Combi Slot Torx screw					
7	Coupling guard					
-	Kit, Gaskets			96455090	1	
37	O-ring					
38	O-ring					
38	O-ring					
109	O-ring		Diameter: 22,00 Material type: EPDM Thickness: 2,75			
-	Kit, Plug			96505133	1	
-	18	Air vent screw Spindle Plug				
23b	Spindle					
25	Plug					
25	Plug					
38	O-ring					
38	O-ring					
38	O-ring		Diameter: 16,3 Material type: FKM Thickness: 2,4			
38	O-ring		Diameter: 16,3 Material type: FKM Thickness: 2,4			
-	Kit, Shaft seal HQQE			96455086	1	
+ 105	Shaft seal		Material type: HQQE			
-	Kit, Wear parts		Material type: SILICON CARBIDE	96455095	1	
-	4a	Chamber w. bearing cpl. Vane Retainer Guide vane				
4a	Intermediate chamber					
45	Neck ring					
47	Bearing bush					
65	Retainer for seal ring					
65	Neck ring retainer					
45	Neck ring					
47a	Bearing ring					
64d	Spacing pipe		Internal diameter: 12,85 Outer diameter: 15,85 Length (mm): 4,50			
64c	Clamp, splined		Internal diameter: 8,5 Outer diameter: 15			

Company name: Parkway Process Solutions
Created by: Parkway Process Solutions
Phone: +61 (0) 390 693 200
Email: solutions@pwnps.com
Date: 11/15/2021

Pos	Description	Annotation	Classification Data	Part no.	Qty.	Unit
65	Neck ring retainer					
66	Wedge lock washer					
67	Lock nut		Thread: M8			
441b	Gasket					
-	Motor				1	
-	Kit, Adapter			98345796		
- 252a	Adapter set					
	Adapter					
	Adapter					
167	Cable gland					
-	Kit, Bearing cpl.			98330603		
111	Ball bearing		Designation: 6204.2Z.C3.SYN			
153	Ball bearing		Designation: 6204.2Z.C3.SYN			
156d	Gasket		Internal diameter: 114,80			
			Outer diameter: 121,20			
			Thickness: 0,25			
156c	Seal ring					
158a	O-ring		Diameter: 47			
			Material type: NBR			
			Thickness: 3			
158	Waved washer					
-	Kit, Blanking plug			98334761		
252b	Plug cpl.					
-	Kit, Cable gland			98337336		
- 293	Cable glands set			98271484		
167	Cable gland					
167	Cable gland					
-	Kit, Connector plugs			98403113		
266	Connector plug 10-pole					
266	Connector plug 2-pole					
266	Connector plug 8-pole					
266	Connector plug 8-pole					
266	Connector plug 8-pole					
266	Connector plug 3-pole					
266	Connector plug 3-pole					
266	Connector plug 3-pole					
-	Kit, Control box			98606007		
152	Pan head thread forming screw					
178	Pan head thread forming screw					
251d	Pan head thread forming screw					
251b	Control box					
251a	Control box					
252b	Plug cpl.					
268a	Base					
268	Pan head screw					
273b	Battery					
273	Funct. Module cpl.					
275a	Pin					
277a	Cross recess Pan head screw					
277a	Cross recess Pan head screw					
277a	Cross recess Pan head screw					
277	Isolation cover					
286	Spacer					
287	Cover					
288b	Retaining ring					
288a	Pan head thread forming screw					

Company name: Parkway Process Solutions
Created by: Parkway Process Solutions
Phone: +61 (0) 390 693 200
Email: solutions@pwnps.com
Date: 11/15/2021

Pos	Description	Annotation	Classification Data	Part no.	Qty.	Unit
288	Wire clamp					
289	Wire clamp					
290	Control panel, cpl.					
-	Kit, Control box upper			98334768		
251d	Pan head thread forming screw					
251b	Control box					
-	Kit, Control panel			98939971		
290	Control panel, cpl.					
-	Kit, Cover			98330622		
287	Cover					
-	Kit, Fan			98290123		
152	Pan head thread forming screw					
156c	Seal ring					
156	Fan					
-	Kit, Flange (DE)			98290125		
156d	Gasket		Internal diameter: 114,80			
			Outer diameter: 121,20			
			Thickness: 0,25			
156b	Flange					
185	Cross recess Pan head screw					
186	Drain plug					
-	Kit, Funct. module			98334777		
273a	Cross recess Pan head screw					
273	Funct. Module cpl.					
275a	Pin					
286	Spacer					
-	Kit, Isolation cover			98330624		
277a	Cross recess Pan head screw					
277	Isolation cover					
-	Kit, Lower part cpl.			98330614		
178	Pan head thread forming screw					
251a	Control box					
275a	Pin					
277a	Cross recess Pan head screw					
277	Isolation cover					
-	Kit, Motor			98293684		
	Terminal					
111	Ball bearing		Designation: 6204.2Z.C3.SYN			
150	Stator					
150	Stator housing					
151	Fan cover					
152	Pan head thread forming screw					
153	Ball bearing		Designation: 6204.2Z.C3.SYN			
156d	Gasket		Internal diameter: 114,80			
			Outer diameter: 121,20			
			Thickness: 0,25			
156c	Seal ring					
156c	Seal ring					
156b	Flange					
156	Fan					
157	O-ring		Diameter: 47			
			Material type: NBR			
			Thickness: 3			
158	Waved washer					
172	Shaft w/rotor					
178	Pan head thread forming screw					

Company name: Parkway Process Solutions
Created by: Parkway Process Solutions
Phone: +61 (0) 390 693 200
Email: solutions@pwnps.com
Date: 11/15/2021

Pos	Description	Annotation	Classification Data	Part no.	Qty.	Unit
185	Cross recess Pan head screw					
186	Drain plug					
203	Terminal plug					
289a	Pan head thread forming screw					
-	Kit, Plug			99369622		
	Terminal					
203	Terminal plug					
205	Pan head thread forming screw					
-	Kit, Screws			98330627		
268a	Base					
268	Pan head screw					
288b	Retaining ring					
288a	Pan head thread forming screw					
288	Wire clamp					
289a	Pan head thread forming screw					
289	Wire clamp					
	Pan head thread forming screw			99598708		
111	Ball bearing		Designation: 6204.2Z.C3.SYN	97914979		
152	Pan head thread forming screw			99834207		
152	Pan head thread forming screw			99814578		
156d	Gasket		Internal diameter: 114,80	99406425		
			Outer diameter: 121,20			
			Thickness: 0,25			
186	Drain plug			99980519		
251d	Pan head thread forming screw			98995460		
2a	Pump head			96588151	1	
+ 4a	Chamber w. bearing cpl.			98371208	1	
+ 4a	Chamber w. bearing cpl.			97690601	1	
+ 4a	Chamber w. bearing cpl.			97690590	1	
+ 4a	Chamber w. bearing cpl.			96547660	1	
+ 4a	Chamber w. bearing cpl.			98371207	1	
- 4	Chamber cpl.			97690020	2	
45	Neck ring			96536194		
65	Retainer			92501765		
65	Retainer			98270018		
65	Retainer			92501764		
+ 4	Chamber cpl.			96547662	2	
+ 4	Chamber cpl.			98371206	2	
+ 5a	Chamber cpl.			98371205	1	
+ 5a	Chamber cpl.			96588148	1	
6	Base			96588138	1	
7a	Combi Slot Torx screw			96886324	4	
10	Shaft pin		Diameter: 5	96536473	1	
			Length (mm): 26			
10	Shaft pin		Diameter: 5	96587588	1	
			Length (mm): 26			
+ 18	Air vent screw			96547461	1	
+ 18	Air vent screw			95061351	1	
- 25a	Priming valve cpl.			96588242	1	
38	O-ring			99198815		
38	O-ring			99412727		
25	Plug			96536013	1	
26	Staybolt		Length (mm): 97	96536314	4	
			Thread: M12			
26	Staybolt		Length (mm): 97	98986269	4	
			Thread: M12			

Company name: Parkway Process Solutions
Created by: Parkway Process Solutions
Phone: +61 (0) 390 693 200
Email: solutions@pwnps.com
Date: 11/15/2021

Pos	Description	Annotation	Classification Data	Part no.	Qty.	Unit
32	Washer		Designation: DIN 125 A Internal diameter: 13 Outer diameter: 24 Thickness: 2,5	99883474	4	
36	Hex nut		Thread: M12	96620479	4	
37	O-ring			96547656	2	
38	O-ring			99198815	2	
38	O-ring			99412727	2	
+ 44a	Guide vane cpl.			96547659	1	
47a	Bearing ring			97905743	1	
47a	Bearing ring			96547649	1	
49	Impeller cpl.			98426771	4	
49	Impeller cpl.			96547599	4	
49	Impeller cpl.			98394415	4	
51	Shaft, spline, cpl.			96588199	1	
55	Outer sleeve			98811265	1	
60	Formed wire spring			99935918	1	
64c	Clamp, splined		Internal diameter: 8,5 Outer diameter: 15	98496968	1	
64a	Spacing pipe			96536198	2	
66	Wedge lock washer			96536157	1	
66	Wedge lock washer			92575609	1	
67	Lock nut		Thread: M8	98277008	1	
+ 105	Shaft seal		Material type: HQQE	96983415	1	
441b	Gasket			96536206	2	
+ 441a	Flange		Thread: RP 1	96547453	2	