

# Chemical Dosing Systems

Polymaster

# Chemical dosing systems – made easy at Polymaster for all applications

Flexible dosing options available ranging from a stand alone cabinet to a complete package including:

- Instrumentation
- Electrical (power control panel)
- Pipework and valves
- Dosing pumps
- Weatherproof connection point

A robust cabinet design provides the operators with a safe environment to monitor & maintain all equipment.



## PLUG 'N' PLAY

Easy install onsite



## SECURE

Lockable doors to keep system safe



## UV RESISTANT

Suitable for outdoor application



## VERSATILE

Provision for electrical and instrumentation



## WEATHERPROOF

to protect your dosing system



## CHEMICAL RESISTANT

PE material not subject to corrosion



## INTEGRATED

Can be fitted to Polymaster double walled tanks



## SAFE

View windows to check for leaks



Visit our website for more  
→ [polymaster.com.au](https://polymaster.com.au)

# Dosing Cabinet

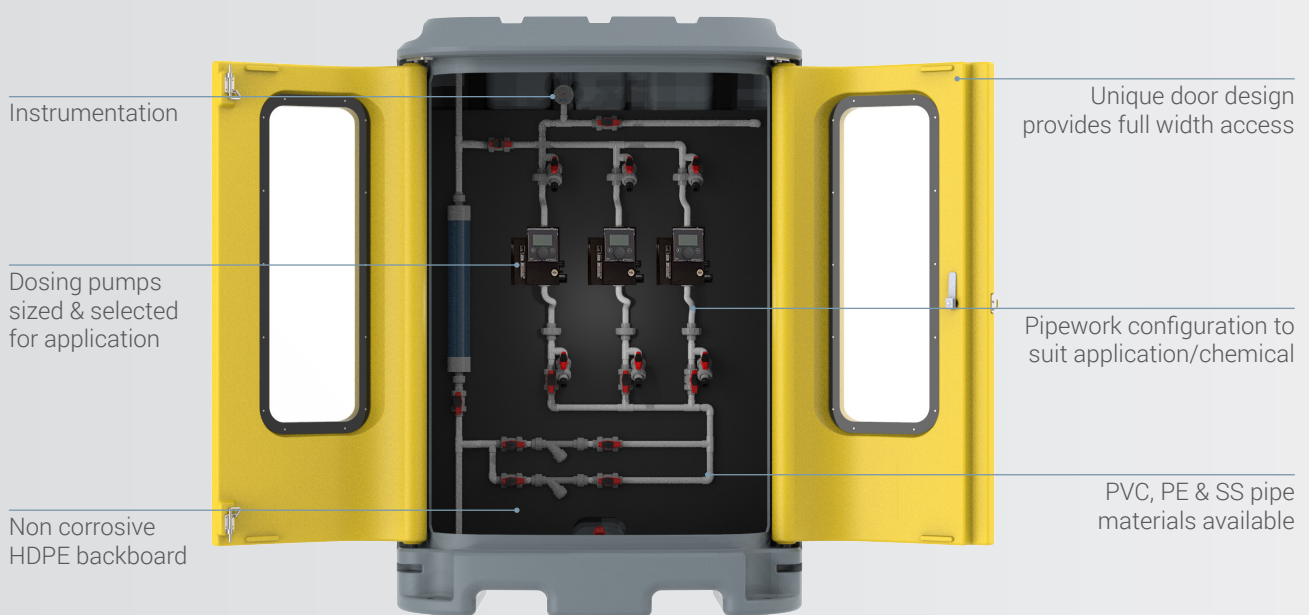

# Options

## INTEGRATED WITH SELF BUNDED TANK



## CUSTOMISABLE PIPEWORK



## SPECIFICATIONS - DOUBLE DOOR CABINET

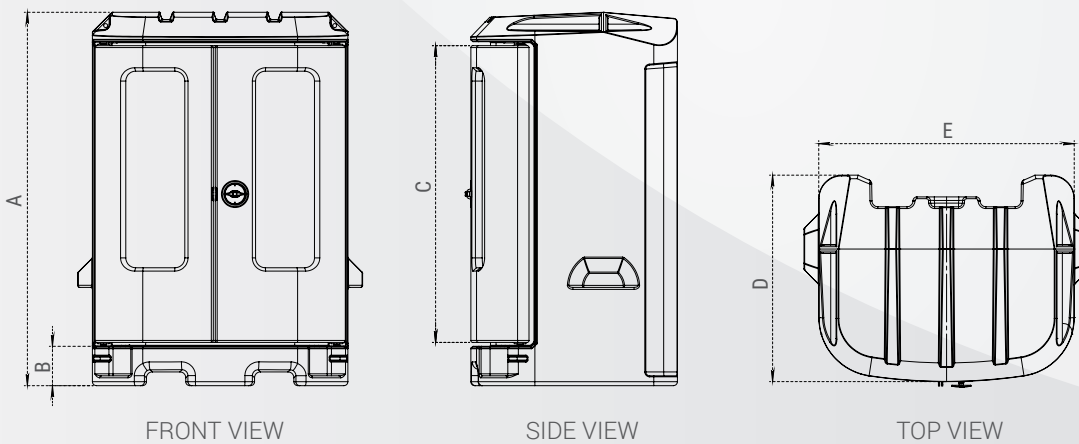

CODE	A (MM)	B (MM)	C (MM)	D (MM)	E (MM)
CAB-DDASYDOSYEL	1900	200	1510	1051	1300

- 1300 062 064
- [industrial.polymaster.com.au](http://industrial.polymaster.com.au)

Follow us  Polymaster Group

Together we  
hold the future.

