

IWAKI PUMPS
AUSTRALIA PTY LIMITED



Solutions for chemical handling applications

Iwaki Pumps Australia

Iwaki Pumps Australia distributes and supports Iwaki products throughout the Australia-Pacific and Middle East regions.

Iwaki Pumps Japan are a world leading manufacturer of pumps for corrosive chemicals, with offices and joint venture partners in over 20 countries.

Iwaki Pumps Australia combines over 100 years of local knowledge and experience with the resources of Iwaki Japan to offer a solution for practically every chemical handling application, including non-metallic Magnetic Drive Pumps, electronic, digital and motorised Metering Pumps plus Chemical Dosing Systems.

Our Water Treatment Controllers, plus Metallic Seal-less Magnetic Drive, Hose, Air Driven Diaphragm, Drum and Specialized Non-Metallic Mechanically Sealed pumps complement our core product range, to provide a total chemical handling solution.

As Australia's only specialist Chemical Pump solution provider, Iwaki Pumps Australia combines Australian support and expertise with the resources of the Iwaki factory. We are one of the few overseas Iwaki operations to assemble and test much of our range in Australia to Japanese factory standards. Iwaki's head office and main plants are located in Japan, with local assembly to strict factory standards established in Europe, U.S.A. and Australia.

Committed to Quality

One of the reasons for Iwaki's product popularity is our focus on safety and durability with a Zero Defects mindset. Development of inherently safe designs and the relentless pursuit of durability helps us to meet the demanding needs of our customers.



Chemical Transfer Pumps

Iwaki manufacture the world's widest range of non-metallic magnetic drive pumps under a single brand. Capacities range from 5L/min to 5,000L/min and offer a range of wetted materials to handle almost any chemical.

Iwaki has recently introduced a metallic range of seal-less magnetic drive centrifugal pumps, for use in Pharmaceutical, Refinery, Specialty Chemical, Explosive and Mining Floatation Reagents, where 304 or 316 stainless steel is a site requirement.

NON-METALLIC RANGE INCLUDES:

- **MD** – A worldwide best-seller, Iwaki's legendary compact magnetic drive pumps
- **MX** – Representing state of the art design in medium sized non-metallic magnetic drive pumps
- **MXM** – Magnetic drive pumps with an excellent balance of features and performance
- **MDM** – Versatile, heavy duty magnetic drive process pumps resistant to dry running
- **MDE** – Heavy duty, large capacity magnetic drive process pumps
- **MDW** – The world's largest class fluoroplastic magnetic drive pump
- **SMX** – Versatile self priming magnetic drive pumps with enhanced tolerance to abnormal operation

METALLIC RANGE INCLUDES:

- **MSW** – Regenerative turbine vane for low flow, high head applications
- **MMP** – A small durable and reliable leak free design
- **MP** – A compact, highly efficient small to medium size pump
- **MTFO** – Large robust open impeller design

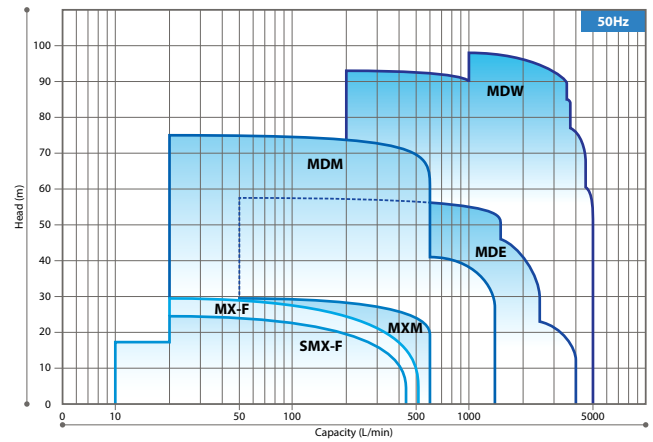
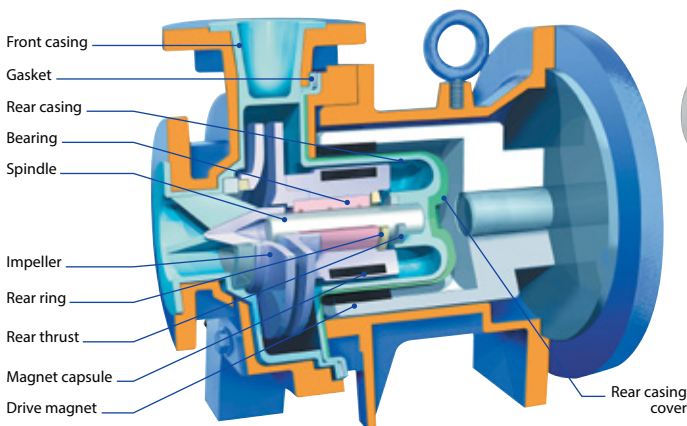

ACCESSORIES:

- **DRN Series** – Dry run protection device



Chemical Dosing Pumps

Iwaki's dosing pump range include economical solenoid units for light duty applications up to large motorised hydraulic diaphragm pumps for heavy industry. A range of electronically controlled digital metering pumps complements the range for applications requiring high turndown or integration into automated systems.

DOSING PUMP RANGE INCLUDES:

- **EJ-R** – Electromagnetic metering pump offering precise chemical injection with an economical cost.
- **EWN** – Electromagnetic dosing pumps with wide range of control features and functions options include auto-degassing, flow and pressure sensors
- **IX** – Advanced digital metering pump technology with BLDC stepper motor, the most energy efficient of all stepper motor designs.
- **LK** – Robust motorised metering pumps cover a wide range of industrial applications
- **AX** – Heavy duty hydraulic diaphragm dosing pumps with high accuracy and longest service life

ACCESSORIES

All the necessary dosing accessories such as tubing, valves, fittings, signal cables, flow checkers/monitors, chemical tanks, chemical gaskets and more.

- **Foot Valve / Strainers** – PVC & PVDF
- **Check Injector Valves** – Inline check valves, in PVC & PVDF, available for smaller dosing pumps
- **Back & Pressure Relief Valves** – PVC, PVDF & 316SS, available for all Iwaki dosing pumps
- **NRD Series** – Diaphragm rupture detection kits, available for LK and AX series dosing pumps
- **Pulsation Dampners** – PP, CPVC, PVDF & 316SS, for all Iwaki dosing pumps
- **Calibration Columns** – PVC, PP & glass
- **CTU Series** – Chemical Tanks with pump recess. In 25, 50 & 120 Litre sizes

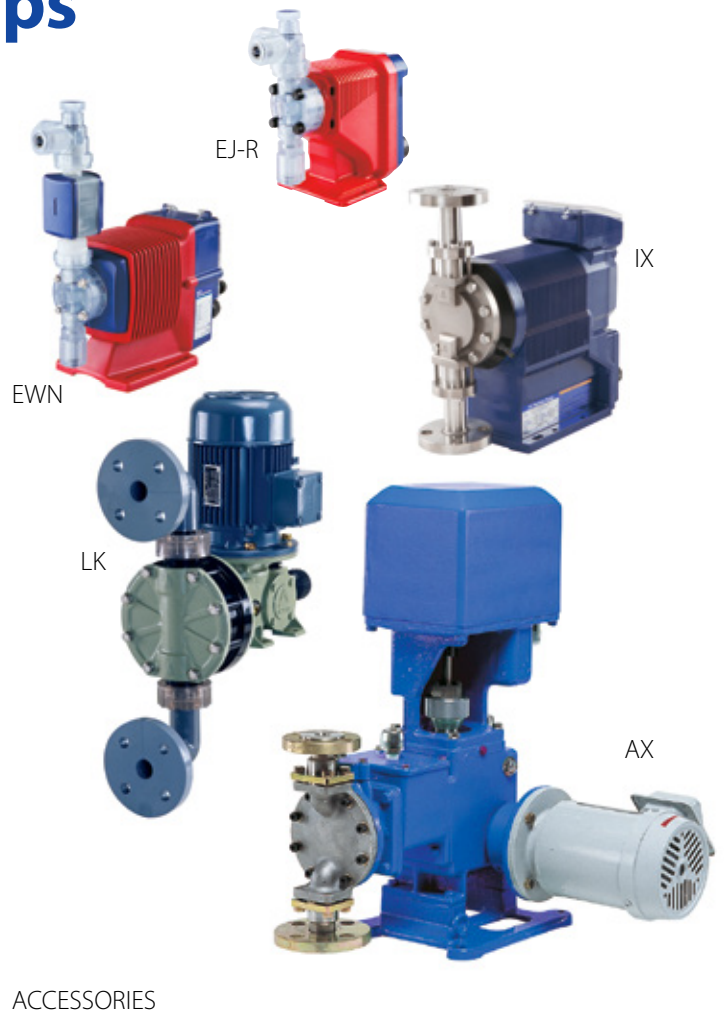

Systems & Skids

We can incorporate any of our products into packaged systems to simplify system installation, from self-contained portable dosing stations to large systems incorporating multiple pumps and controls.

From initial discussion and design brief, through to generating GA Drawings and fabrication of our skidded systems, we work with our clients to provide industry leading solutions.

All our skidded systems are manufactured in Australia by highly skilled technicians with an absolute quality focus, mirroring that of our products.



Pre-Engineered Dosing Systems

Our pre-engineered packages provide simple and convenient chemical dosing solutions suitable for many industrial & municipal applications.

- Rugged moulded UV stabilized LDPE pump stands
- Exceptional chemical resistance to chemicals such as sodium hypochlorite
- One-piece seamless moulding provides in-built spill containment with drain connection
- Standard designs house single or twin / electronic or BLDC motorised dosing pumps with all necessary tubing, pipework and accessories for ease of installation
- Other dosing accessories available depending on application requirements.

Factory assembled & hydrostatically tested for fast onsite commissioning. Eliminates difficult installation logistics on remote sites.

- Compact and efficient use of space while maintaining operator space requirements
- Can be floor or wall-mounted.



Water Treatment Controllers

Iwaki-Walchem has a wide range of analytic control instrumentation and packages available for various industrial water treatment applications, including Municipal and Industrial Water and Wastewater, Cooling Towers, Boilers, Postharvest Disinfection, plus Commercial Pools and Spas.

CONTROLLER RANGE INCLUDES:

- **W100** – Three powerful control outputs make the Walchem W100W a more versatile, high value choice among entry level water treatment controllers. Universal sensor input provides extraordinary flexibility; the same controller can be used with almost any type of sensor needed. Multiple language support allows simple setup no matter where your business takes you
- **W600** – Feature a large touchscreen display with icon based programming to make setup easy. Universal sensor input provides extraordinary flexibility; the same controller can be used with almost any type of sensor needed. Six control outputs allow the controller to be used in more applications
- **W900** – The new standard for Industrial Water Treatment Controllers. Provides unparalleled versatility in maintaining your water treatment operations

VTouch - W600 and W900 controllers connected via GPRS modem or LAN cable fully synchronize with the VTouch account manager, providing on-line web-based summary of account status.

- One click live connect
- Real Time data
- Alarm status
- Analysis, troubleshooting, adjustments
- Access and permission management
- All accounts on a single page
- No set up or ongoing fees to host and store your data
- free software updates

W100



W600



W900



Extended Range

ALH SERIES HOSE PUMPS

THE ALH pump is very easy to use and maintain and therefore addresses what we at Iwaki Pumps Australia see as two of the key customer issues: the need to lower costs and to reduce down-time. The ALH series is designed to make hose changes quick and easy with no technical knowledge required. The ALH series pump is an extremely reliable pump with a wide performance range, up to 150 m³/h and 15 Bar, that can handle most fluids in most applications.



YAMADA PUMPS

As a leader in pneumatic pumping technology, Yamada is known in many industries worldwide for its innovative products, superior quality, and unmatched reliability. An impressive history of product design and engineered solutions establishes Yamada as the forerunner in industrial pump technology. Suppliers of air operated double diaphragm pumps – engineered and manufactured in Japan. Used for corrosive liquids, inks, solvents and dewatering.

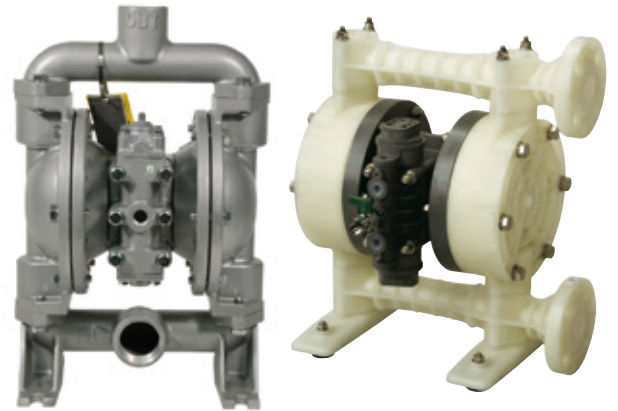

MUNSCH PUMPS

We are proud to be the sole Australian Distributor for Munsch Chemie-Pumpen of Germany. Horizontal and Vertical Pumps in accordance with EN22858 that feature fully non-metallic wetted parts in PP, HDPE, PVdF, SiC, FKM and EPDM. With proprietary bi-directional, self loading and adjusting mechanical seal design and capacities up to 2,000m³/hr and heads to 110m, these exceptionally robust pumps have earned a reputation for quality, durability and low maintenance.

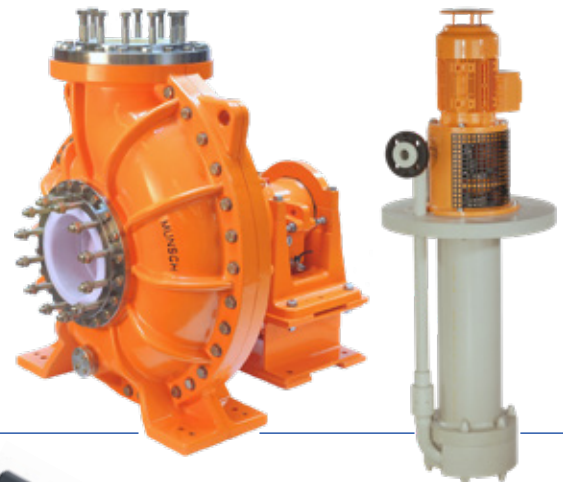

STANDARD DRUM PUMPS

Standard Pump, Inc. began manufacturing Drum Pumps in 1992 in Snellville, Georgia. Standard Pump supply Iwaki Australia with their comprehensive range of Chemical Drum Pumps. When you need fluid handling equipment for your chemical, industrial, water treatment or automotive application, you can have confidence in the safety and performance of Standard Drum Pumps.



Sydney Head Office
IWAKAI PUMPS AUSTRALIA
1/7 Salisbury Road, Castle Hill
NSW 2154
iwaki@iwaki-pumps.com.au
Phone: 02 9899 2411 Fax: 02 9899 2421

Melbourne Branch Office
IWAKAI PUMPS AUSTRALIA
2/3 Westside Avenue, Port Melbourne
VIC 3207
viciwaki@iwaki-pumps.com.au
Phone: 03 9558 8053 Fax: 03 9558 8123

Brisbane Branch Office
IWAKAI PUMPS AUSTRALIA
1/3970 Pacific Highway, Loganholme,
QLD 4129
qldiwaki@iwaki-pumps.com.au
Phone: 07 3375 1747 Fax: 07 3375 1806

Distributors in all other states.
Please contact Sydney Head Office for
details.



**IWAKI PUMPS
AUSTRALIA PTY LIMITED**

