

AQUADYN® UA420

Hollow Fiber UF Modules

AQUADYN® UA420 UF modules feature a 0.025-micron pore size **Polyacrylonitrile (PAN)** hollow fiber membrane potted in a U-shaped arrangement. These modules are most suitable for POU (Point-of-Use), POE (Point-of-Entry), and commercial water and wastewater treatment systems. They operate at a very low feed pressure due to the high hydrophilicity of PAN membrane, which leads to energy savings. This product specification sheet provides an overview of relevant technical data regarding AQUADYN® UA420 modules.

MEMBRANE CHARACTERISTICS

Membrane Polymer	Polyacrylonitrile (PAN)
Nominal Pore Size	0.025 µm
Membrane Type	Hollow Fiber
Hollow Fiber Diameter OD/ID	2.1 mm / 1.1 mm (0.083 inch / 0.043 inch)

MODULE SPECIFICATIONS

Housing Material	Reinforced PP
Membrane Potting	Epoxy
Type of Filtration	Out → In Dead-End
Operating Mode	Dead-End
Preservative	Sodium meta-bisulphite
Nominal Membrane Area	6 m ² (65 ft ²)

OPERATING PARAMETERS

Maximum Filtrate Flow	0.72 m ³ /h (3.2 gpm)
Maximum Feed Pressure (at 20°C / 68°F)	4.0 bar (58.0 psi)
Maximum Transmembrane Pressure	3.0 bar (43.5 psi)
pH Range for Operation	2.0 - 10.0
Temperature Range	5 - 45°C (41 - 113°F)

CLEANING PARAMETERS

pH Range	1.0 - 10.0
Max. Temperature	45°C (113°F)
Max. Active Chlorine Concentration	100 ppm
Max. Active Chlorine Exposure	100,000 ppm-hours
Max. Hydrogen Peroxide Concentration	500 ppm
Max. Hydrogen Peroxide Exposure	500,000 ppm-hours



UA420-E



UA420-BT



UA420-BB

PHYSICAL DIMENSIONS

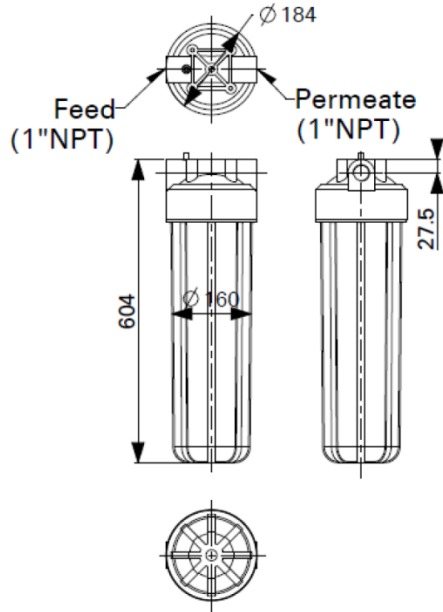

Dry Weight	8 kg (17.6 lb)
Module Diameter	160mm (6.3in)
Module Length	604mm (23.8in)
Feed Port	1" NPT
Permeate Port	1" NPT
UA420-E	Fiber element only
UA420-BT	Transparent housing
UA420-BB	Blue housing

IMPORTANT INFORMATION

Storage & Handling:

AQUADYN® UA420 modules must be handled and stored appropriately to ensure proper operation and to prevent membrane damage. Please see AQUADYN® UA420 Product Manual.

Installation and Start-up:

AQUADYN® UA420 modules must be installed correctly before start-up. For a detailed installation and start-up procedure, please see AQUADYN® UA420 Product Manual.

Cleaning:

AQUADYN® UA420 modules must be cleaned routinely via backwash to ensure proper operation and to prevent membrane damage. Please see AQUADYN® UA420 Product Manual.

MICRODYN-NADIR reserves the right to change specifications without prior notification.

Contact

Europe

Germany: +49 611 962 6001
 Italy: +39 0721 1796201
 info@microdyn-nadir.com

Americas

USA: +1 805 964 8003
 sales.mnus@microdyn-nadir.com

Asia

Singapore: +65 6457 7533
 China: +86 10 8413 9860
 waterchina@mann-hummel.com