

AQpure

Modular water treatment system



1. Product introduction	3
2. Application examples	4
AQpure with AQtap water dispenser	4
AQpure with a grid of AQtap water dispensers	5
3. Water quality categorisation	6
AQpure raw water matrix	6
Water quality limits	6
Overview of pre-treatment options	7
4. Product configuration	9
Configuration depending on water category	9
Type key	9
5. Product description	10
AQpure modules	10
Technical data	13
Dimensions	13
6. Product selection	14
7. Service offerings	16
Installation and operation	16
Repair and maintenance	16
Spare parts and maintenance kits	16
Surveillance and mobility	16
8. Accessories and spare parts	17
Accessories	17
Spare parts	18
9. Appendix	19
Explanation of water parameters	19
Piping and instrumentation diagram (PID)	20
10. Grundfos Product Center	21

1. Product introduction

The Grundfos AQpure water treatment system produces potable water by filtering bacteria, viruses and particles from raw source water, providing a reliable and affordable water supply even in remote areas. The water treatment is based on ultrafiltration (UF) technology.

Standardised treatment modules can be combined according to the specific raw water quality on site to deliver a complete water treatment unit.

Easy to install

The AQpure system is flexible and easy to install. It is delivered prefabricated and prewired as plug-and-play water treatment system. AQpure can easily be combined with other required treatment processes such as sedimentation, sand filtration, aeration.

Optimised adaptability

- AQpure can be adapted to the local raw water quality.
- Optional modules can be added to match the specific water treatment requirements.

Minimal downtime and optimal reliability

- The complete preventive maintenance schedule is delivered by Grundfos.
- Regular maintenance can easily be carried out by local operators.
- Professional service is required only 1 to 4 times a year, depending on the raw water quality.
- Grundfos Remote Management offers control and service planning.
- AQpure consists of high-quality components.
- Patented self-adaptive control software reacts to seasonal changes and maximises service intervals.

Minimal operation costs

- Solar powering fully and partly possible
- Low consumption of energy
- Low consumption of chemicals
- Long lifetime of the membrane and other wear parts
- No need for a full-time operator

Applications

AQpure can operate as a stand-alone drinking water system or in combination with Grundfos AQtap water dispensers in water kiosk applications. The AQpure water treatment system can also be applied in water factories and bottling stations or at selected industrial sites, commercial buildings and estates.

AQpure water treatment system



Fig. 1 AQpure water treatment system with external CIP unit

TM06 4931 3115

2. Application examples

Grundfos offers a wide range of high-quality pumps, controls, and intelligent water dispensers with revenue collection. When combined with the AQpure, systems can be designed to meet project-specific requirements and criteria.

AQpure with AQtap water dispenser

An AQpure water treatment system with an AQtap water dispenser is the complete solution for a sustainable water supply in rural and peri-urban areas, which are not connected to the main water network.

Ground water or surface water is pumped to the AQpure water treatment system, where it is purified. The purified water is stored in a tank, which can be connected to a water kiosk with an AQtap water dispenser.

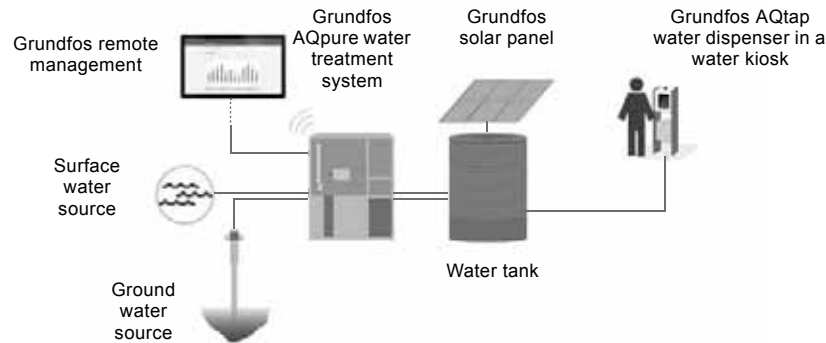

TM06 4604 2615

Fig. 2 AQpure application with AQtap water dispenser

Key components

- Water source
- Grundfos pump solution
- Grundfos AQpure water treatment system
- Water tank
- Grundfos AQtap water dispenser
- Grundfos remote management GRM
- Grundfos 100 S solar panels
 - Option 1:
 - 3 solar panels are connected in series, 5 sets of 3 solar panels each are connected in parallel. For more details, see page 17.
 - Option 2:
 - 2 solar panels are connected in series, 7 sets of 2 solar panels each are connected in parallel. For more details see page 17.

Recommendations for installation

- Select a configuration that matches the local water quality.
- Select the distribution module to be able to pump the treated water to the elevated water tank.
- Include a level sensing module to make sure, that the AQpure system runs in accordance with the water consumption.

AQpure water treatment system

- AQpure should be installed inside a solid building for protection from vandalism and tampering. The building should be accessible only to authorized people.

Water tank

- The tank must be high enough for gravity feed. It is not possible to feed the dispenser directly from an AQpure system on the same level. The tank outlet should be placed at least 3 m above the AQtap dispenser inlet. Grundfos can provide a pump solution.
- The tank should have a lateral water outlet to avoid sediment entering the dispenser. Install the tank in a way that it can be emptied and cleaned.

AQpure with a grid of AQtap water dispensers

A complete grid of water dispensers can be supplied with water from one water treatment system. This is a reliable and efficient solution for a water supply infrastructure for larger settlements in peri-urban and rural areas, which are not connected to the main water network.



TM06 4605 2615

Fig. 3 AQpure application with mini-grid of water dispensers

Key Components

- Water source
- Grundfos pump solution
- Grundfos AQpure water treatment system
- Water tank
- Grid of Grundfos AQtap water dispensers
- Grundfos remote management
- Grundfos 100 S solar panels
 - Option 1:
 - 3 solar panels are connected in series, 5 sets of 3 solar panels each are connected in parallel. For more details, see page 17.
 - Option 2:
 - 2 solar panels are connected in series, 7 sets of 2 solar panels each are connected in parallel. For more details, see page 17.

Recommendations for installation

- Select a configuration that matches the local water quality.
- Select the distribution module to be able to pump the treated water to the elevated water tank.
- Include a level sensing module to make sure, that the AQpure system runs in accordance with the water consumption.

AQpure water treatment system

- AQpure should be installed inside a solid building for protection from vandalism and tampering. The building should be accessible only to authorized people.

Water tank

- The tank must be high enough for gravity feed. It is not possible to feed the dispenser directly from an AQpure system on the same level. The tank outlet should be placed at least 3 m above the AQtap dispenser inlet. Grundfos can provide a pump solution.
- The tank should have a lateral water outlet to avoid sediment entering the AQtap dispenser. Install the tank in a way that it can be emptied and cleaned.

3. Water quality categorisation

The AQpure system consists of different modules. The quality of the raw water on site determines, which modules are necessary for the water treatment process.

The first step in the selection of the appropriate combination of modules is to determine the water treatment challenge at hand. For this purpose, we

developed the AQpure raw water matrix, which enables you to categorise the raw water into four water types: blue, green, brown and orange. The basis for this categorisation is the content of selected pollutants, referred to as water quality parameters in the table below.

AQpure raw water matrix

Parameter group	Water quality parameter	Blue water Ground water, rain water or public water	Green water Pond water	Brown water River water in wet season	Orange water Rivers and lakes in tropical areas
		Low fouling	Organic fouling	Inorganic fouling	Organic & inorganic fouling
Solids	Turbidity [NTU]	< 3	3-10	10-100	10-100
	TSS [mg/l]	< 5	5-10	> 10	5-50
	SDI15	< 5	5	< 5	> 5
Dissolved organics	DOC [mg/l]	< 5	5-10	< 5	10-20
	UV254 [1/m]	< 0.1	0.1 - 0.3	> 0.5	0.3 - 0.5
	COD [mg/l]	< 15	15-30	< 15	30-50
	Oil [mg/l]	< 0.1	0.1 - 0.3	< 0.1	0.3 - 0.5
Dissolved inorganics	Fe/Mn [mg/l]	< 0.05	0.05 - 0.2	> 1	> 0.5
	Water hardness (CaCO ₃) [mg/l]	< 60		> 60	
	Conductivity [µS/cm]	< 500		500-1000	
Water chemistry and temperature	pH	6-9			
	Temperature [°C]	10-35			

For [Explanation of water parameters](#) see [9. Appendix](#) on page 19.

Water quality limits

UF membranes are very effective barriers for pollutants. Coarse pollutants bigger than 300 µm and abrasive particles must be removed from the water entering the system.

The customer is responsible for the relevant pre-treatment of the water. Before entering the UF treatment process, the water quality must comply with the values stated in the table below. Otherwise the warranty is voided.

Parameter group	Water quality parameter	Required feed water quality
Solids	Turbidity [NTU]	< 5
	TSS [mg/l]	< 5
	SDI15	< 5
Dissolved organics	DOC [mg/l]	< 10
	UV254 [1/m]	< 0.3
	COD [mg/l]	< 20
	Oil [mg/l]	0
Dissolved inorganics	Fe/Mn [mg/l]	< 0.1
	Water hardness (CaCO ₃) [mg/l]	< 60
	Conductivity [µS/cm]	< 1000
Water chemistry and temperature	Cl ₂ [ppm]	max 0.5 continuously
	pH	6-9
	Temperature [°C]	10-40

Water samples

Grundfos highly recommends to take representative water samples on a regular basis, to be able to observe the values of the determined water parameters.

It has to be considered to:

- Take several samples from different spots due to changes in the aquatic system
- Ensure that the values account in the middle of the range and not to the critical boundaries
- Consider seasonal changes in the water quality. Take several samples covering a broad time range and weather conditions.

Overview of pre-treatment options

The AQpure raw water matrix indicates the application range of the AQpure water treatment system, and shows that in many cases a pre-treatment process has to be performed. The following text introduces some of the common state-of-the-art water treatment processes in brief.

	Blue water	Green water	Brown water	Orange water
	Low fouling	Organic fouling	Inorganic fouling	Organic and inorganic fouling
Pre-treatment examples	none	Coagulation Sedimentation	Sedimentation Aeration Sand filtration	Coagulation Sedimentation Aeration Sand filtration

Description of pre-treatment processes

Coagulation and flocculation

Coagulation and flocculation are two complementary and consecutive processes used to separate colloids from water. A colloid is a suspension of very small particles with electrically charged surface, which does not allow them to bind and settle.

Coagulation is the first process step to be carried out. The coagulation process causes destabilisation of colloidal particles in a suspension by the addition of a chemical reagent (coagulant). As a result, small agglomerations are formed.

The entire process can be divided into the following steps:

1. Dosing and mixing: uniform addition of the chemicals.
2. Destabilisation of the colloid: the coagulation process starts. The small particles' charge is counteracted by the coagulation agent.
3. Aggregation to micro flocks: fast combination of the uncharged small particles composing the colloid to form small flocks, by the application of a high shear gradient, without flocculation agents (or coagulant aids).
4. Aggregation to macro flocks: the flocculation process starts. The micro flocks start to bridge together. Low shear forces and no turbulence are necessary to avoid breaking up the flocks. This step can be performed with or without a chemical flocculation agent.

Today, plenty of products are available which combine coagulation and flocculation with one chemical. This simplifies the process significantly. The dosing rate must be defined by a JAR test. The dosing rate and dilution factor are strictly depending on the water matrix and the way of mixing.

A flocculation process is followed by a sedimentation or flotation process to remove the created flocks.

Sedimentation

The simplest separation process to remove coarse and fine solids from the raw water is sedimentation. In the sedimentation process, the particles in the water are given the time to settle at the bottom of the tank, so they are separated from the water. In some cases, the sedimentation process should be combined with a proper intake solution to avoid high peak loads of solids. Separation by sedimentation or settling can take place intermittently or continuously. Intermittent processes are used only in small installations in which the aeration and settling phases occur in the same unit. Settling is a continuous process.

In a settling tank:

- The flow must be even, with good raw water distribution and uniform recovery of the settled water.
- The flow must be as non-turbulent as possible. Energy dissipation at the water inlet must be gradual.
- Flow, concentration and the removal of sludge and solids are essential for the proper functioning of the unit. The concept of solids loading or even sludge volume loading is very important.

Examples of settling times

Material	Size	Settling time per metre
Gravel	10 mm	1 sec
Coarse sand	1 mm	10 sec
Fine sand	0.1 mm	125 sec
Clay	0.01 mm	108 min
Bacteria	0.001 mm	189 hours
Colloids	0.0001 mm	755 days

Aeration and filtration

Dissolved iron and manganese in combined concentrations of 5-10 mg/l can be treated with aeration and filtration. Air is sucked in and mixed with the passing stream of water to oxidise the iron and manganese into particles. The air-saturated water enters the precipitator/aerator vessel where the air is separated from the water. The water passes a multimedia filter which takes out the oxidised iron and manganese particles. The removal of manganese requires more time and oxygen than the removal of iron.

Aeration is not recommended for water containing organic complexes of iron/manganese or iron/manganese bacteria, which will clog the subsequent filter very fast.

Examples of oxidant requirements for iron and manganese oxidation:

Oxidant	per mg/l Mn	per mg/l Fe
Oxygen (from aeration)	0.29	0.14
Ozone	0.67	0.43
Chlorine	1.28	0.63
Potassium permanganate	1.92	0.94
Chlorine dioxide	2.4	1.2

Please note that the above table shows theoretical figures from the literature. The industrial practice is different. For the right oxidation level, volume, tank shape, reaction time have to be considered.

Degasification

Air stripping is used to remove volatile organic compounds (VOC), ammonia, H₂S, CO₂ or oxygen from water. Typically a stripping tower is used to remove the above mentioned gases. Water is pumped to the top of the tower which is packed with surface increasing media. The water is evenly distributed across the media, and flows downwards gravity-driven. Air is blown upwards from the bottom, contacting the water surface. Mass transfer drives the removal of volatile species. For industrial water treatment, membrane-based degasification is mainly used to remove CO₂ and oxygen.

Sand filtration

Sedimentation, coagulation/flocculation and aeration processes are typical treatment stages that precede filtration. Chemical additives, such as coagulants, can be used in conjunction with the filtration system.

In deep-media filtration, the raw water passes through a filter bed made of granular material. The layer depth is an important parameter that depends on the type of filter used. The active filter layer usually has a depth of 1-3 m. Suspended solids are retained in the intergranular spaces throughout the greater part of the layer depth. Filter velocity, intergranular space volume and granular sizing are essential parameters.

A periodic backwash sequence is the most important maintenance step involved in operation to ensure proper performance. The intervals of backwash depend on the kind of solids, pressure range, holding volume, freeboard volume, available flow rates, etc. A filtration time of 8-72 hours between each backwash should be calculated.

Slow sand filter

Slow granular filter bed filtration belongs to the category of depth filters, where the effluent is passed through a filter bed filled with between 0.5 and 2 metres of sand. By straining, adhesion, interception, etc., the particulate matters are retained in the filter.

Slow sand filters act as biologically active filters, because a biofilm builds up, which consumes the available organic matter in the fluid. The water passes the filter bed by gravity.

A typical design of sand layers:

- 0.2 - 0.3 m, granular size 0.15 - 0.50 mm
- 0.4 - 0.6 m, granular size 0.50 - 1.0 mm
- 0.2 - 0.3 m, granular size 1.50 - 2.0 mm
- 0.1 - 0.2 m, granular size 3.0 - 6.0 mm

Rapid sand filters

Rapid sand filters use coarse sand and other granular media to remove particles and impurities that have been trapped in a flock by flocculation chemicals. Water and flocks flow through the filter medium, and the flocculated material is trapped in the sand.

Rapid sand filters do not use biological filtration and depend primarily on adsorption and straining.

Rapid sand filters can work with gravity or under pressure. Rapid sand filtration has very little effect on taste and odour and dissolved impurities, unless activated carbon is included in the filter medium.

In rapid sand filters the following granular sizes are commonly used:

0.62 - 1.00 mm	Swimming pools
0.72 - 1.25 mm	Well water treatment in combination with coagulation
1.00 - 2.20 mm	Direct filtration of surface water in combination with coagulation

4. Product configuration

Configuration depending on water category

Combination	UF process only	Blue water Ground water, rain water or public water				Green water Pond water		Brown water River water in wet season		Orange water Rivers and lakes in tropical areas	
		C2	C3	C4	C5	C6	C7	C8	C9	C10	C11
Self-cleaning prefilter	-	-	-	-	-	■	■	■	■	■	■
Standard UF	■ ²⁾	■ ²⁾	■ ²⁾	■ ²⁾	■ ²⁾	■	■	■	■	■	■
Air scouring	-	-	-	■	■	-	■	■	■	■	■
Chlorination	-	■	-	■	-	■	■	■	-	■	■
Internal CIP	-	-	-	-	-	-	■	-	-	■	■
Level sensing	□	□	□	■	■	□	■	□	■	□	■
Activated carbon filter	-	-	-	■	■	-	■	-	■	-	■
UV disinfection	□	-	■	-	■	□	□	-	■	□	■
Distribution	□	□	□	■	■	□	■	□	■	□	■
Solar package	□	□	□	□	□	□	□	□	□	□	□
Remote management	□	■	■	■	■	■	■	■	■	■	■

■ Built-in module

□ Optional module

- Not selectable

1) Must be combined with auxiliary equipment

2) Includes 300 µm strainer

Type key

Example: AQP-UF-1-C1-PL-UV-D-SP-RM

	Code	Description
Type	AQP	AQpure
Technology	UF	Ultrafiltration
Number of modules	1	1 module
Main combination	C1	Combination 1
	C2	Combination 2
	C3	Combination 3
	C4	Combination 4
	C5	Combination 5
	C6	Combination 6
	C7	Combination 7
	C8	Combination 8
	C9	Combination 9
	C10	Combination 10
	C11	Combination 11

Optional modules

Level sensing	PL	Level sensing
	X	No level sensing
UV disinfection	UV	UV disinfection
	X	No UV
Distribution	D	Distribution
	X	No distribution
Solar package	SP	Solar package
	X	No solar package
Remote management	RM	Remote management (GRM)
	X	No remote management

AQpure selection tool

Grundfos provides a selection tool for the easy configuration of AQpure.

Based on the determined water parameters and specific requirements, the appropriate combinations and accessories are suggested. The AQpure selection tool can be acquired from the local Grundfos representative.

5. Product description

AQpure modules

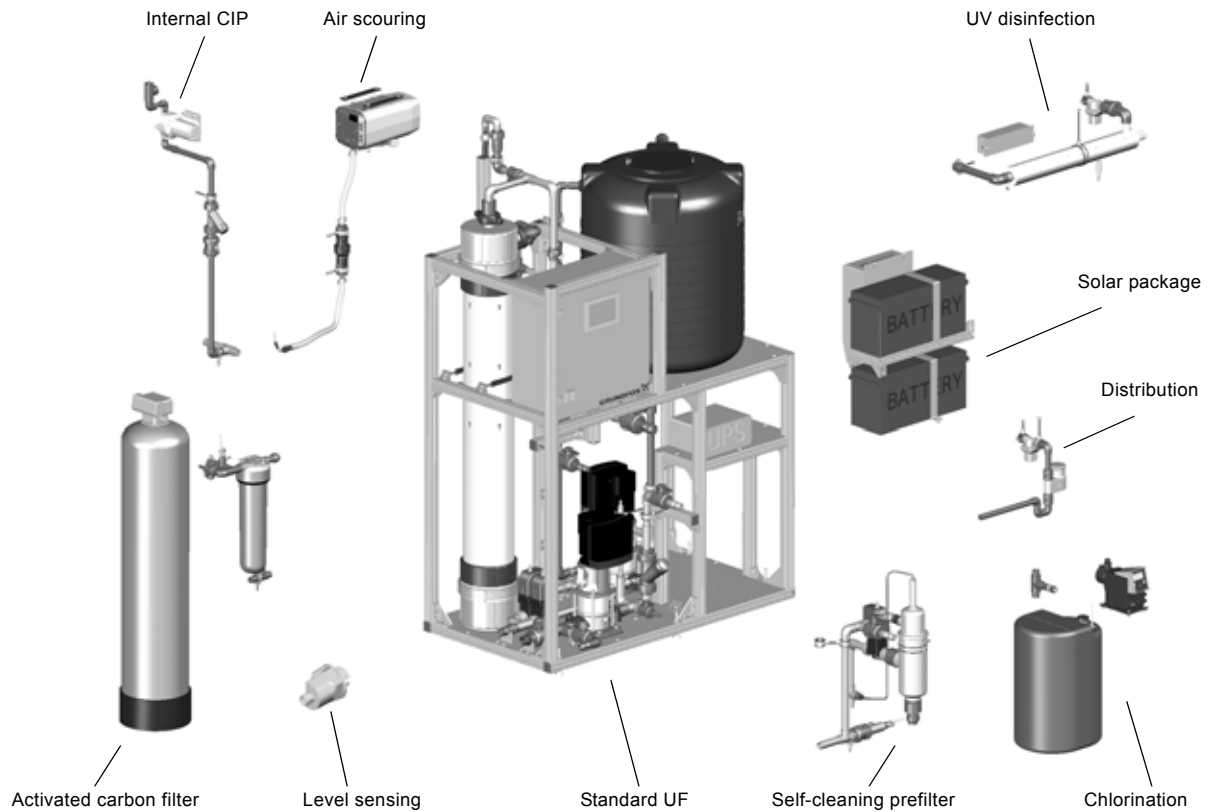
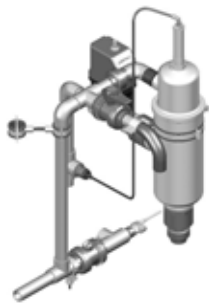

Fig. 4 Overview of AQpure modules

TM06 5253 4215

Self-cleaning prefilter



TM06 3899 1215

The self-cleaning prefilter on the water inlet of the AQpure removes suspended solids $> 100 \mu\text{m}$.

Main components:

- Prefilter
- Motor valve
- Pressure sensor

Standard UF

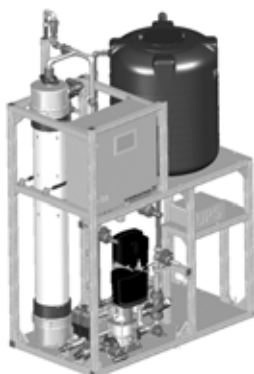

TM06 3898 1215

The standard UF module performs the ultrafiltration treatment step, and removes bacteria, viruses, and particles including colloids.

Main components:

- UF membrane
- Feed pump
- Backwash pump
- Internal water tank
- Motor valves
- Pressure sensors
- Flow sensors
- Temperature sensor
- PLC
- Aluminium frame

Air scouring



TM06 5254 4215

The air scouring/PDT module blows a large amount of air into the UF membrane to improve the backwash. The Pressure Decay Test (PDT) can be performed with the air scouring/PDT module.

Main component:

- Air pump

Chlorination



TM06 3900 1215

The chlorination module offers the possibility to disinfect the produced water with residual effect. Chlorine is also used to enhance backwash of the UF membrane and internal CIP (Clean In Place) process.

Main components:

- Dosing pump
- Chlorine tank with level switch

Internal CIP



TM06 3895 1215

In combination with the chlorination module, the internal Clean In Place (CIP) module provides improved cleaning of the UF membrane. The combination of both is also referred to as Chemical Enhanced Backwash (CEB).

Main components:

- Circulation pump
- Dosing pump
- Chlorine tank with level switch

Level sensing



TM06 4381 2115

A pressure sensor is used for the tank level control of the external buffer tank. The sensor signals when to start and stop the production and when to start and stop transferring water from the internal tank to the external buffer tank.

Activated carbon filter



TM06 5255 4215

The activated carbon filter module removes chemicals from the water, particularly organic chemicals that are responsible for odour and taste.

Main components:

- Activated carbon filter
- Multiport valve (MPV)
- Pressure sensors
- Solenoid valve
- Cartridge filter

UV disinfection

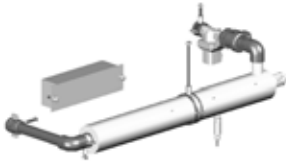

TM06 3896 1215

The UV disinfection module disinfects the produced water without the use of chemicals.

Main components:

- UV lamp
- UV intensity sensor
- Solenoid valve

Distribution



TM06 5256 4215

The water meter in the distribution module provides precise measurement of the water distributed by the system. The distribution module is required to be able to pump treated water to an elevated external buffer tank. See section [AQpure with AQtap water dispenser](#) on page 4.

Main components:

- Water meter
- Solenoid valve

Solar package

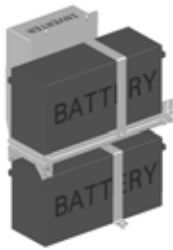

TM06 3901 1215

The power for the AQpure can be supplied by an external power source provided by the customer, by a solar package, or by a combination of both.

Main components:

- Breaker box for the PV array connection
- Breaker box between batteries and bi-directional inverter
- Bi-directional inverter including a solar charger
- Two batteries

Remote management



TM06 4382 2115

Grundfos remote management provides remote monitoring of operational status and performance. Broadcasting of alarms and software updates are possible.

Main components:

- Router (Ethernet switch) with firewall function

Technical data

Water production	0.5 to 2 m ³ /h
Membrane type	Hollow fibre, dead-end, outside-in
Membrane material	PVDF
Membrane pore size	0.03 µm
Control strategy	Parametric to be very flexible
Inlet pressure	max. 1 bar at 1 m ³ /h
Power supply	200-240 V, 1-phase, 50/60 Hz
Control interface	PLC based 7" touchscreen
Weight	Empty: 400-615 kg; Filled: 750-1165 kg

Dimensions

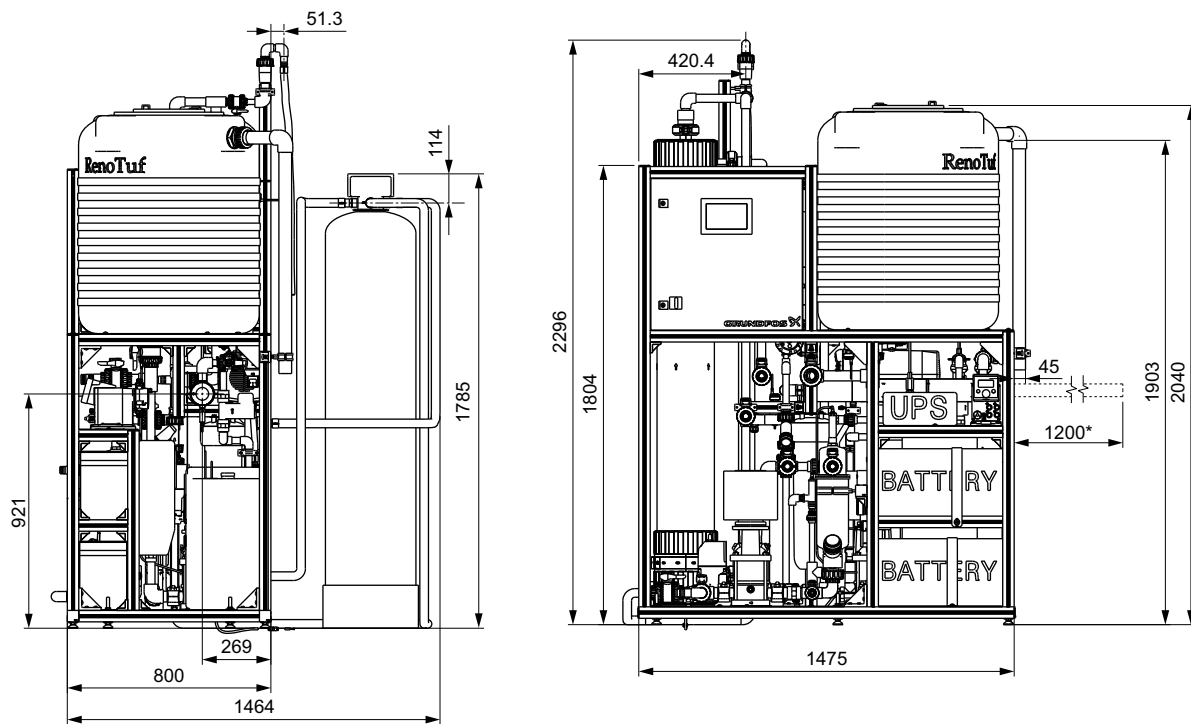

* Space required for maintenance of UV disinfection module

TM06 3890_2 1215

Fig. 5 Front and side view of an AQpure system

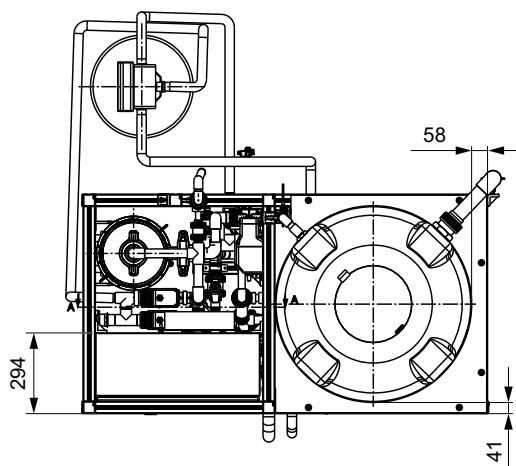

TM06 4769 2915

Fig. 6 Top view of an AQpure system

Transport dimensions and weights

Description	Packing box dimensions [mm]			Weight [kg]
	Length	Width	Height	
AQpure system with standard UF module only	1660	1030	2240	429
AQpure system with all modules	1740	1135	2240	612
External CIP unit	840	850	1215	93
UF membrane	2000	355	550	75
Activated carbon filter	2000	500	565	67

6. Product selection

AQP-UF-1

Combination	Level sensing	UV disinfection	Distribution	Solar package	Remote management	Type key	Product number		
	PL	UV	D	SP	RM				
C1	PL	UV	D	SP	RM	AQP-UF-1-C1-PL-UV-D-SP-RM	98890381		
				No SP	No RM	AQP-UF-1-C1-PL-UV-D-SP-X	98890382		
				No SP	RM	AQP-UF-1-C1-PL-UV-D-X-RM	98890383		
			No D	No SP	No RM	AQP-UF-1-C1-PL-UV-D-X-X	98890384		
				SP	RM	AQP-UF-1-C1-PL-UV-X-SP-RM	98890385		
		No UV	No D	No SP	No RM	AQP-UF-1-C1-PL-UV-X-SP-X	98890386		
				No SP	RM	AQP-UF-1-C1-PL-UV-X-X-RM	98890387		
			D	No SP	No RM	AQP-UF-1-C1-PL-UV-X-X-X	98890388		
				SP	RM	AQP-UF-1-C1-PL-X-D-SP-RM	98890389		
			No D	D	No SP	No RM	AQP-UF-1-C1-PL-X-D-SP-X	98890390	
					No SP	RM	AQP-UF-1-C1-PL-X-D-X-RM	98890391	
				No UV	No SP	No RM	AQP-UF-1-C1-PL-X-D-X-X	98890392	
					SP	RM	AQP-UF-1-C1-PL-X-X-SP-RM	98890393	
					No D	No SP	No RM	AQP-UF-1-C1-PL-X-X-SP-X	98890394
						No SP	RM	AQP-UF-1-C1-PL-X-X-X-RM	98890395
	No PL	UV	D	SP	RM	AQP-UF-1-C1-X-UV-D-SP-RM	98890397		
				No SP	No RM	AQP-UF-1-C1-X-UV-D-SP-X	98890398		
				No SP	RM	AQP-UF-1-C1-X-UV-D-X-RM	98890284		
			No D	No SP	No RM	AQP-UF-1-C1-X-UV-D-X-X	98890285		
				SP	RM	AQP-UF-1-C1-X-UV-X-SP-RM	98890286		
		No UV	No D	No SP	No RM	AQP-UF-1-C1-X-UV-X-SP-X	98890287		
				No SP	RM	AQP-UF-1-C1-X-UV-X-X-RM	98890288		
			D	No SP	No RM	AQP-UF-1-C1-X-UV-X-X-X	98890289		
				SP	RM	AQP-UF-1-C1-X-X-D-SP-RM	98890290		
				No SP	No RM	AQP-UF-1-C1-X-X-D-SP-X	98890291		
				No SP	RM	AQP-UF-1-C1-X-X-D-X-RM	98890292		
			No D	No UV	No SP	No RM	AQP-UF-1-C1-X-X-D-X-X	98890293	
					SP	RM	AQP-UF-1-C1-X-X-X-SP-RM	98890294	
				No UV	No SP	No RM	AQP-UF-1-C1-X-X-X-SP-X	98890295	
					No SP	RM	AQP-UF-1-C1-X-X-X-X-RM	98890296	
No SP	No RM	AQP-UF-1-C1-X-X-X-X-X			98890297				
SP	RM	AQP-UF-1-C2-PL-X-D-SP-RM			98890298				
C2	PL	No UV	D	SP	RM	AQP-UF-1-C2-PL-X-D-X-RM	98890299		
				No SP	No RM	AQP-UF-1-C2-PL-X-X-SP-RM	98890300		
			No D	No SP	No RM	AQP-UF-1-C2-PL-X-X-X-RM	98890301		
	SP			RM	AQP-UF-1-C2-X-X-D-SP-RM	98890302			
	No PL		D	No SP	No RM	AQP-UF-1-C2-X-X-D-X-RM	98890303		
				SP	RM	AQP-UF-1-C2-X-X-X-SP-RM	98890304		
No D		No SP	No RM	AQP-UF-1-C2-X-X-X-X-RM	98890305				
C3	PL	UV	D	SP	RM	AQP-UF-1-C3-PL-UV-D-SP-RM	98890306		
				No SP	No RM	AQP-UF-1-C3-PL-UV-D-X-RM	98890307		
			No D	No SP	No RM	AQP-UF-1-C3-PL-UV-X-SP-RM	98890308		
	SP			RM	AQP-UF-1-C3-PL-UV-X-X-RM	98890309			
	No PL		D	No SP	No RM	AQP-UF-1-C3-X-UV-D-SP-RM	98890310		
				No SP	No RM	AQP-UF-1-C3-X-UV-D-X-RM	98890311		
No D		SP	RM	AQP-UF-1-C3-X-UV-X-SP-RM	98890312				
C4	PL	No UV	D	No SP	No RM	AQP-UF-1-C4-PL-X-D-SP-RM	98890314		
				No SP	No RM	AQP-UF-1-C4-PL-X-D-X-RM	98890315		
C5	PL	UV	D	SP	RM	AQP-UF-1-C5-PL-UV-D-SP-RM	98890318		
				No SP	No RM	AQP-UF-1-C5-PL-UV-D-X-RM	98890319		

Combination	Level sensing	UV disinfection	Distribution	Solar package	Remote management	Type key	Product number
	PL	UV	D	SP	RM		
C6	PL	UV	D	SP	RM	AQP-UF-1-C6-PL-UV-D-SP-RM	98890322
				No SP		AQP-UF-1-C6-PL-UV-D-X-RM	98890323
			SP	AQP-UF-1-C6-PL-UV-X-SP-RM		98890324	
			No SP	AQP-UF-1-C6-PL-UV-X-X-RM		98890325	
		No UV	D	SP		AQP-UF-1-C6-PL-X-D-SP-RM	98890326
				No SP		AQP-UF-1-C6-PL-X-D-X-RM	98890327
			No D	SP		AQP-UF-1-C6-PL-X-X-SP-RM	98890328
				No SP		AQP-UF-1-C6-PL-X-X-X-RM	98890329
	No PL	UV	D	SP	AQP-UF-1-C6-X-UV-D-SP-RM	98890330	
				No SP	AQP-UF-1-C6-X-UV-D-X-RM	98890331	
			No D	SP	AQP-UF-1-C6-X-UV-X-SP-RM	98890332	
				No SP	AQP-UF-1-C6-X-UV-X-X-RM	98890333	
		No UV	D	SP	AQP-UF-1-C6-X-X-D-SP-RM	98890334	
				No SP	AQP-UF-1-C6-X-X-D-X-RM	98890335	
			No D	SP	AQP-UF-1-C6-X-X-X-SP-RM	98890336	
				No SP	AQP-UF-1-C6-X-X-X-X-RM	98890337	
C7	PL	UV	D	SP	RM	AQP-UF-1-C7-PL-UV-D-SP-RM	98890338
				No SP		AQP-UF-1-C7-PL-UV-D-X-RM	98890339
		No UV	D	SP		AQP-UF-1-C7-PL-X-D-SP-RM	98890342
				No SP		AQP-UF-1-C7-PL-X-D-X-RM	98890343
C8	PL	No UV	D	SP	RM	AQP-UF-1-C8-PL-X-D-SP-RM	98890346
				No SP		AQP-UF-1-C8-PL-X-D-X-RM	98890347
			No D	SP		AQP-UF-1-C8-PL-X-X-SP-RM	98890348
				No SP		AQP-UF-1-C8-PL-X-X-X-RM	98890349
	No PL	No UV	D	SP		AQP-UF-1-C8-X-X-D-SP-RM	98890350
				No SP		AQP-UF-1-C8-X-X-D-X-RM	98890351
			No D	SP		AQP-UF-1-C8-X-X-X-SP-RM	98890352
				No SP		AQP-UF-1-C8-X-X-X-X-RM	98890353
C9	PL	UV	D	SP	RM	AQP-UF-1-C9-PL-UV-D-SP-RM	98890354
				No SP		AQP-UF-1-C9-PL-UV-D-X-RM	98890355
C10	PL	UV	D	SP	RM	AQP-UF-1-C10-PL-UV-D-SP-RM	98890358
				No SP		AQP-UF-1-C10-PL-UV-D-X-RM	98890359
			No D	SP		AQP-UF-1-C10-PL-UV-X-SP-RM	98890360
				No SP		AQP-UF-1-C10-PL-UV-X-X-RM	98890361
		No UV	D	SP		AQP-UF-1-C10-PL-X-D-SP-RM	98890362
				No SP		AQP-UF-1-C10-PL-X-D-X-RM	98890363
			No D	SP		AQP-UF-1-C10-PL-X-X-SP-RM	98890364
				No SP		AQP-UF-1-C10-PL-X-X-X-RM	98890365
	No PL	UV	D	SP	AQP-UF-1-C10-X-UV-D-SP-RM	98890366	
				No SP	AQP-UF-1-C10-X-UV-D-X-RM	98890367	
			No D	SP	AQP-UF-1-C10-X-UV-X-SP-RM	98890368	
				No SP	AQP-UF-1-C10-X-UV-X-X-RM	98890369	
		No UV	D	SP	AQP-UF-1-C10-X-X-D-SP-RM	98890370	
				No SP	AQP-UF-1-C10-X-X-D-X-RM	98890371	
			No D	SP	AQP-UF-1-C10-X-X-X-SP-RM	98890372	
				No SP	AQP-UF-1-C10-X-X-X-X-RM	98890373	
C11	PL	UV	D	SP	RM	AQP-UF-1-C11-PL-UV-D-SP-RM	98890374
				No SP		AQP-UF-1-C11-PL-UV-D-X-RM	98890375

7. Service offerings

The service offerings described here ensure optimal functioning of the AQpure system with respect to:

- highly optimised system performance
- minimal energy consumption
- reduced operational costs
- low downtime on site

All service offerings listed below can be purchased individually and locally at Grundfos Service & Solutions. Our Authorised Service Partner network helps us secure a dependable and global availability of service products.

For further information contact your local Grundfos company or service partner or see:

<http://www.grundfos.com/service-support.html>

Installation and operation



Commissioning

- **Check of installation**
During commissioning, all aspects of your Grundfos AQpure system are checked, if it is correctly installed and ready for start-up.
- **Commissioning**
Commissioning is crucial to avoid breakdown of the AQpure system during operation.
- **Train the operator**
Certified service staff trains your operator in the basic maintenance tasks and writes a detailed report including the activities realised, the parameters measured, and gives recommendations. Your operator will be able to keep the system running at optimal conditions.

Service contracts

- **Professional maintenance and repair service**
With a Grundfos service contract, you get dependable and professional service and maintenance, making sure that your installation remains in top condition and runs in an energy efficient manner.
- **Two-level service contract**
To suit your needs, two different levels of service contracts are available: Basic and Advanced.
- **Maximal reliability at low costs**
Regular scheduled service work with replacement of components maximises the reliability of the system and keeps the running costs low.

Repair and maintenance



On-site repair

Certified service staff takes care of maintenance and repair tasks. This provides you with the following advantages:

- Minimised downtime and expenditure due to fast and efficient repair work
- Repair work is performed in such a way that the product warranty remains valid
- No need to spend time and resources in dismantling installations, sending components for repairs, and reassembling installations afterwards
- Clear overview of repair costs

Spare parts and maintenance kits



Spare parts and maintenance kits

- Each maintenance kit is tailor-made for one specific maintenance operation.
- One-stop shop solution: You'll get all the suitable original spare parts and maintenance kits at one place.
- Spare parts can be ordered at the local Grundfos sales company or the Service and Sales Partner.
- Grundfos Distribution Service offers 24/7 global delivery options

Surveillance and mobility



Grundfos Remote Management

Expert service engineers perform remote monitoring of the key parameters of your AQpure system.

- When a critical event occurs, you are informed immediately by a warning or alarm, which avoids a breakdown of your system.
- Your operator receives assistance and recommendations
- Site visits for troubleshooting are coordinated
- A detailed report that highlights potential problems, gives recommendations and analyses data is sent periodically.

8. Accessories and spare parts

Accessories

External CIP unit

The external CIP (Clean In Place) unit cleans the UF membrane thoroughly with chemicals, in order to reestablish its original performance. Plug and play-ability. Powered by external source.

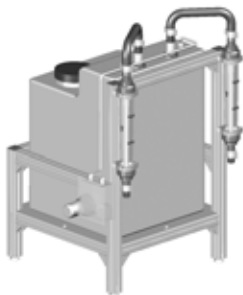

TM06 5257 4215

Fig. 7 External CIP

Main components	Product number
<ul style="list-style-type: none"> • Tank • Heater • Float switch • Connection hoses • 2 flow meters • Non-return valve • Terminal box 	98890378

Voltage stabiliser

A voltage stabiliser is designed to maintain a constant voltage level automatically.



TM06 4773 3015

Fig. 8 Voltage stabiliser

Description	Product number
<ul style="list-style-type: none"> • Model: DVR-590 • Working range: 90-290 V • Load capacity: 5 KVA • Bypass system: yes • Warranty: 1 year 	98890379

AQtap

AQtap is an intelligent water dispenser with integrated revenue collection platform for viable and accountable water supply via smart cards.



TM06 4765 2915

Fig. 9 AQtap

Description	Product number
<ul style="list-style-type: none"> • Hydraulic capacity under normal operation conditions: ~ 1 m3/h • Power supply: <ul style="list-style-type: none"> – grid power AC connection: 110-240 V, 50/60 Hz – solar panel DC voltage: 15-45 V / 3 A • Capacity of included backup-battery: 18 Ah = approx. 12 hours of operation 	98794194

Solar panel GF 100 S

GF 100 S solar modules consist of 72 polycrystalline silicon solar cells in series with 3 bypass diodes. The solar cells are laminated between sheets of ethylene vinyl acetate (EVA) and tempered glass. Each solar module is equipped with plugs and sockets for easy connection of several modules in parallel or series. The solar modules must be mounted on a support structure, tilted at an angle ensuring optimum utilisation of the solar energy.

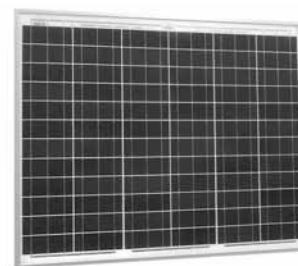

TM06 4768 2915

Fig. 10 Solar panel GF 100 S

Description	Product number
GF 100 S solar panel	98614404
Wire kit for solar panel:	
– Array-to-controller wire kit	98257868
– Array-to-array wire kit	98257892

Option 1

3 solar panels are connected in series. 5 sets of 3 solar panels each are connected in parallel.

It requires:

- 1 array-to-controller wire kit
- 4 array-to-array wire kits

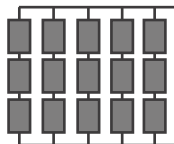

TM06 4659 2915

Fig. 11 Option 1: arrangement of solar panels

Description

- Voltage: 112.8 VDC
- Open circuit voltage: 132.6 VDC
- Current: 13.75 A
- Power: 1500 W
- Dimensions of one panel: 1001*734*34 mm (length/width/height)

Option 2

2 solar panels are connected in series. 7 sets of 2 solar panels each are connected in parallel.

It requires:

- 2 array-to-controller wire kits
- 6 array-to-array wire kits

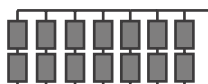

TM06 4660 2915

Fig. 12 Option 2: arrangement of solar panels

Description

- Voltage: 75.2 VDC
- Open circuit voltage: 88.4 VDC
- Current: 19.25 A
- Power: 1400 W
- Dimensions of one panel: 1001*734*34 mm (length/width/height)

Grundfos water quality toolbox

The Grundfos water quality toolbox is a helpful tool to check and monitor the quality of the raw water, the feed water and the produced water. Portable devices and reagents that allow qualitative and quantitative parameter measurement are arranged in a suitcase for field testing. With the Grundfos water quality toolbox, it is easy to categorise the raw water and to select the suitable combination of AQpure modules.



TM06 5460 4715

Fig. 13 Water quality toolbox

Main components	Product number
<ul style="list-style-type: none"> • Portable incubator heater • Photometer • Conductivity measuring device • SDI15 measuring device • Turbidity measuring device • Fe, Mn, pH, TOC, DOC vials • Residual chlorine test • Syringes, filters and other accessories • Instructions 	99013132

Spare parts

Module	Description	Product number
Standard UF	Kit, maintenance feed pump/ backwash pump	99025243
	Spare, UF membrane element	99025244
Prefilter	Kit, prefilter screen	99025245

9. Appendix

Explanation of water parameters

Water parameter	Unit	Interpretation	Source
DOC (dissolved organic carbon)	[mg/l]	<ul style="list-style-type: none"> The amount of carbon bound in an organic compound and is often used as a non-specific indicator of water quality. Measures CO₂ formed when organic carbon is oxidized and/or when inorganic carbon is acidified and then subtract the inorganic carbon from the total carbon. Water needs to be filtered with 0.45 µm filter (preferred pre-flushed filter). 	ISO 8245:1999 ASTM D7573-09
UV254	[1/m]	<ul style="list-style-type: none"> Organics with a high degree of conjugation absorb light in the UV at wavelength of 254 nm of the electromagnetic spectrum, the extent the adsorption indicates the content of humic substances in water. 	UV spectrophotometer at the wavelength of 254 nm
COD (chemical oxygen demand)	[mg/l]	<ul style="list-style-type: none"> Is commonly used to indirectly measure the amount of organic compounds in water, indicates the mass of oxygen consumed per liter of solution. 	ISO 15705:2002, reviewed in 2013 ASTM D1252-06(2012)
Oil	[mg/l]	<ul style="list-style-type: none"> Petroleum compounds in water or oil used in industry can be released into water source due to heavy precipitation, vehicle accident, et al. If oil contact with membrane, it is very difficult to be removed. 	ISO 9377-2:2000 ASTM D7066-04(2011)
Turbidity	[NTU]	<ul style="list-style-type: none"> Measure for the amount of particles in the water Typically measured by light extinction in a water sample Units: <ul style="list-style-type: none"> FNU indicates attenuation through the sample NTU indicates scattered light (more focus on small particles) Turbidity in FNU is not the same as in NTU (latter is preferred) 	ISO 15715:2003 ASTM D7315-12
TSS (total suspended solids)	[mg/l]	<ul style="list-style-type: none"> Solids in water that can be trapped by a filter with a pore size of 0.45 µm. TSS can include a wide variety of material, such as silt, decaying plant and animal matter, industrial wastes, and sewage. High concentrations of suspended solids can cause many problems for stream health and aquatic life. 	ASTM D5907-13
SDI15 (Silt Density Index)		<ul style="list-style-type: none"> A measure for the fouling potential for water Based on standard filtration protocol with micro filtration membranes 	ASTM D4189-07(2014)
Fe/Mn	[mg/l]	<ul style="list-style-type: none"> Water percolating through soil and rock dissolves iron and manganese. In groundwater due to low oxygen content and pH, water containing dissolved iron or manganese appears colourless, but after contacting with oxygen iron changes to reddish-brown while manganese forms a black residue and both foul membrane heavily. 	ASTM D1068-10 ASTM D858-12
Water hardness (CaCO ₃)	[mg/l]	<ul style="list-style-type: none"> Water hardness is the measure of concentration of divalent metal ions such as Ca/Mg per volume of water. It is common to use as unit of this parameter CaCO₃equivalents in ppm or mg/l High content of Ca/Mg has high mineral content due to water percolating through deposits of calcium and magnesium-containing minerals such as limestone, chalk and dolomite. Hard drinking water is generally not harmful to one's health, but can pose serious problems in industrial settings. Under high pH CIP values they may sediment onto membrane and lead to severe fouling. 	ASTM D511-14 ASTM D1126-12
Conductivity	[µS/cm]	<ul style="list-style-type: none"> Presents the ability to conduct electricity and indicating the ionic content in a solution. 	ASTM D1125-14 ISO 7888:1985 (reviewed in 2012)
pH		<ul style="list-style-type: none"> Presents the acidity or basicity of an aqueous solution. Solutions with a pH less than 7 are said to be acidic and solutions with a pH greater than 7 are basic or alkaline pH is the negative logarithm of the activity of the (solvated) hydronium ion. 	ISO 10523:2008 ASTM D1293-12
Temperature	[°C]	<ul style="list-style-type: none"> Temperature affects the viscosity of water. A low temperature indicates more energy needed to push water passing through membrane and correspondingly high transmembrane pressure. Cold temperatures are an indication of infiltration of ground water to the raw water source (to be considered during process design) 	

Piping and instrumentation diagram (PID)

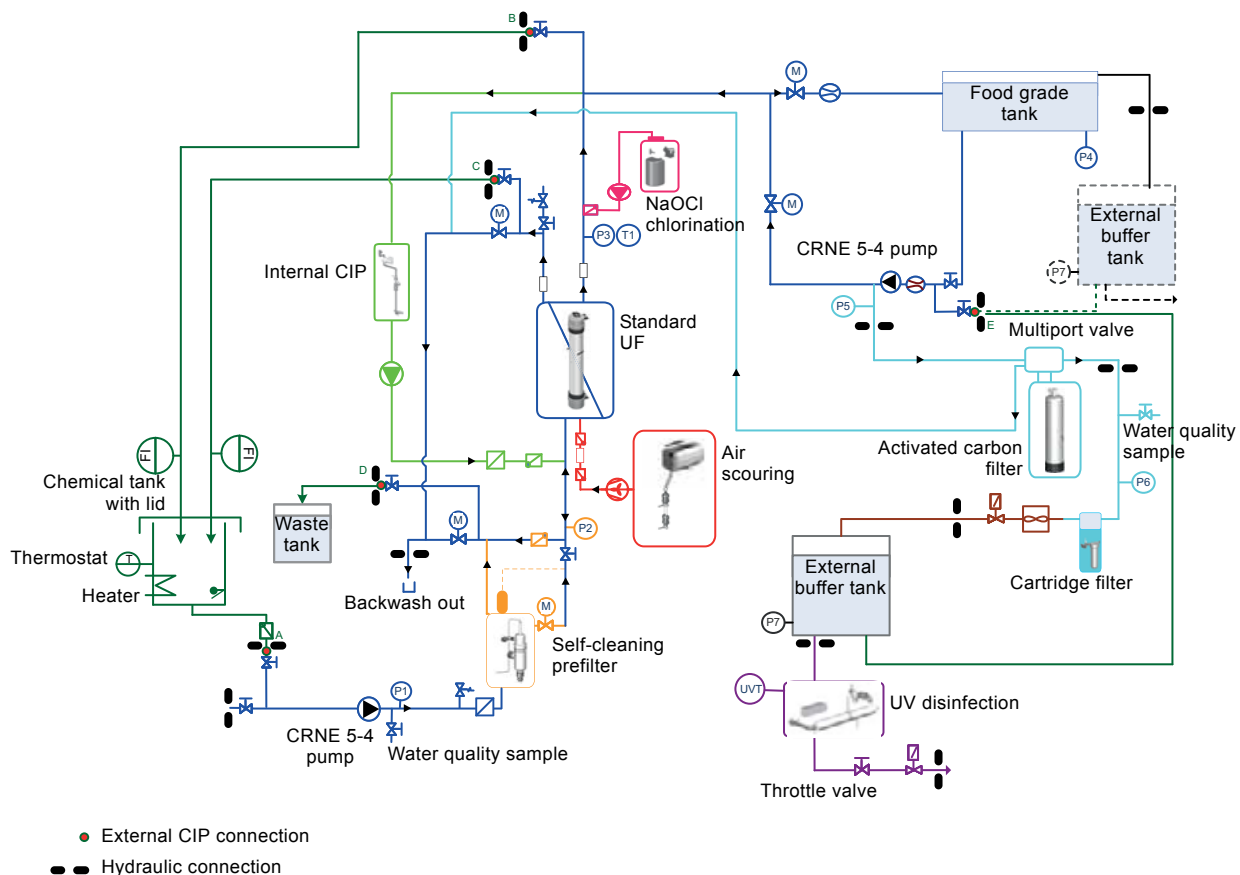

Fig. 14 PID of an AQpure water treatment system

Symbols of the PID

	Flow sensor		Pump		Solenoid valve		Pressure relief valve
	Pressure sensor or temperature sensor		Pipe or hose		Non-return valve		Float switch
	Motor valve		Compressor		Manual valve		Strainer

TM06 3892 1215

10. Grundfos Product Center

Online search and sizing tool to help you make the right choice.

<http://product-selection.grundfos.com>



"SIZING" enables you to size a pump based on entered data and selection choices.

"REPLACEMENT" enables you to find a replacement product. Search results will include information on the following:

- the lowest purchase price
- the lowest energy consumption
- the lowest total life cycle cost.

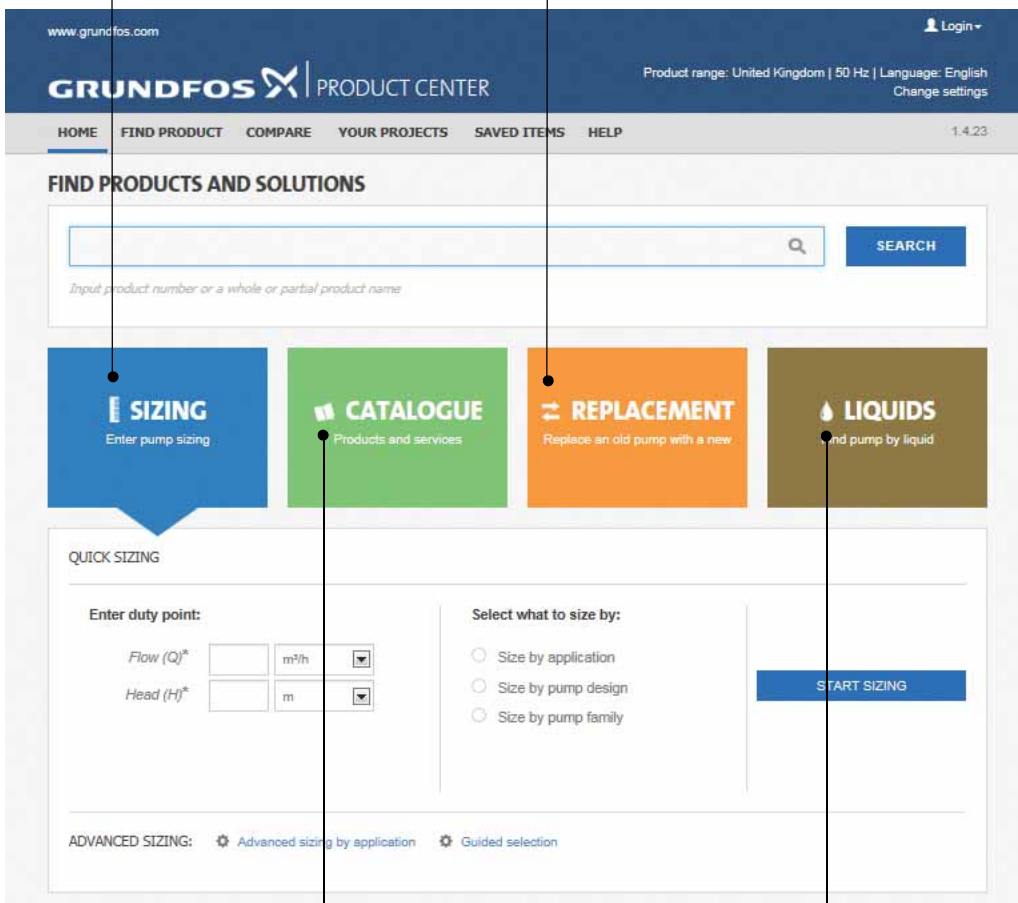

"CATALOGUE" gives you access to the Grundfos product catalogue.

"LIQUIDS" enables you to find pumps designed for aggressive, flammable or other special liquids.

All the information you need in one place

Performance curves, technical specifications, pictures, dimensional drawings, motor curves, wiring diagrams, spare parts, service kits, 3D drawings, documents, system parts. The Product Center displays any recent and saved items - including complete projects - right on the main page.

Downloads

On the product pages, you can download installation and operating instructions, data booklets, service instructions, etc. in PDF format.

Subject to alterations.

be think innovate

98890935 1215

ECM: 1156120

GRUNDFOS A/S
DK-8850 Bjerringbro . Denmark
Telephone: +45 87 50 14 00
www.grundfos.com

GRUNDFOS 

The name Grundfos, the Grundfos logo, and be think innovate are registered trademarks owned by Grundfos Holding A/S or Grundfos A/S, Denmark. All rights reserved worldwide. © Copyright Grundfos Holding A/S