

Service-Manual

Aquinity² P10

ultra pure water system for the production of
ultra pure water directly from tap water
with integrated 10 liter permeate-tank



Revision history

Rev.	Date	Description
2.0.0	2018-02-06	Initial version
2.0.1	2018-02-13	Added FAQ's
2.1.1	2018-03-28	Bug fixes, added touchscreen calibration, simulation, option pressure sensor
2.1.2	2018-07-24	Update chapter 9.1.11; update picture SBC & PI
2.1.3	2018-07-31	Bug T3 fixes
2.1.4	2018-08-28	Update this manual
2.1.5	2018-09-13	Update this manual

Rev. 2.1.5

Software V2.1.8; Firmware V0.13.8

Aquinity² is a registered trademark of *membraPure* GmbH. All rights reserved.

Subject to technical changes without prior notice.

Made in Germany.

Contents

1	General	1
1.1	About this manual.....	1
1.2	Symbols used in this manual	1
1.3	Liability and warranty.....	2
1.4	Copyright.....	2
1.5	Spare parts.....	3
1.6	Disposal.....	3
2	Safety	4
2.1	Intended use.....	4
2.2	Contents of this manual	4
2.3	Changes and modifications to the equipment.....	5
2.4	User responsibility	5
2.5	Personal requirements.....	5
2.6	Health and safety work.....	6
2.7	Personal protective equipment (PPE)	6
2.8	Potential hazards.....	7
3	System Features	8
3.1	General	8
3.2	Series overview	9
3.3	Technical data.....	9
3.4	Purification process.....	10
3.5	Hardware.....	12
3.5.1	<i>Dispenser</i>	12
3.5.2	<i>Control PCB</i>	12
3.5.3	<i>IEC Socket</i>	13
3.5.4	<i>Front- and side-panel</i>	13
4	Installation and start up	15
4.1	Feed water requirements.....	15
4.2	Delivered parts	16
4.3	Setting up the system.....	16
4.4	Sealing plug.....	16
4.5	Connections	17
4.6	Module attachment.....	18
4.7	Vent filter attachment.....	18
4.8	Sterile filter attachment.....	19

4.9	Electrical connection	19
5	System Control Panel.....	20
5.1	Normal operation mode	20
5.2	Tools.....	20
5.2.1	<i>Exchanging consumables.....</i>	<i>20</i>
5.2.2	<i>Exchanging UV-lamp (in the pure water section).....</i>	<i>21</i>
5.2.3	<i>Change all Consumables</i>	<i>22</i>
5.2.4	<i>Exporting Data</i>	<i>23</i>
5.2.5	<i>Prod. to max level.....</i>	<i>23</i>
5.2.6	<i>Process visualization.....</i>	<i>23</i>
5.2.7	<i>Venting UPW.....</i>	<i>24</i>
5.3	History	24
5.3.1	<i>Warning messages</i>	<i>24</i>
5.3.2	<i>Graphical values</i>	<i>24</i>
5.3.3	<i>Logfile</i>	<i>25</i>
5.4	User setup	25
5.4.1	<i>Limits setup.....</i>	<i>25</i>
5.4.2	<i>System time settings.....</i>	<i>26</i>
5.4.3	<i>Reset timers(manually)</i>	<i>26</i>
5.4.4	<i>Operating hours</i>	<i>27</i>
5.4.5	<i>Manual stand by.....</i>	<i>27</i>
5.5	Errors and Countermeasures.....	28
6	Care and maintenance.....	29
6.1	Intervals.....	29
6.2	Replacement of sterile-filter	29
6.3	Modul replacement	30
6.4	Replacement of the UV-lamp.....	31
6.5	Replacement of reverse osmosis module.....	32
6.6	P&I scheme	33
6.7	Consumables	34
6.8	System update	34
7	Users FAQ's	35
8	Contact.....	36
9	Service setup	37
9.1.1	<i>Adjustment conductivity sensors Q and temperature T</i>	<i>37</i>
9.1.2	<i>Limit setting of conductivity sensors.....</i>	<i>38</i>

9.1.3	<i>Read operating hours</i>	38
9.1.4	<i>Limit operating hours</i>	39
9.1.5	<i>Command line</i>	39
9.1.6	<i>System Info. (system-information)</i>	39
9.1.7	<i>Direct access</i>	40
9.1.8	<i>Reset configuration</i>	41
9.1.9	<i>Reset calibration</i>	41
9.1.10	<i>Flushing, disinfection timer</i>	42
9.1.11	<i>Editor .mcf-file</i>	42
9.1.12	<i>Touchscreen calibration</i>	43
9.2	<i>Conductivity measuring amplifier</i>	45
9.2.1	<i>Calibration of the conductivity and temperature measurement</i>	45
9.3	<i>Control board</i>	47
9.4	<i>Single board computer</i>	48
9.5	<i>Software parameters</i>	49
9.5.1	<i>Configuration file (config.mcf)</i>	49
9.5.2	<i>Calibration file (calib.mcf)</i>	51
9.5.3	<i>Operating hours file (op_hour.dat)</i>	52
10	Services FAQ's	52

1 General

1.1 About this manual

This manual describes how to use the equipment safely and correctly. When operating this equipment, it is essential that the user adhere to the safety and operating instructions included in the manual. Local safety and general safety regulations should also be followed when using this equipment.

Before using the equipment, the user must read the entire manual, particularly the section on safety and the relevant safety warnings. The user must fully understand the instructions before operating the equipment.

The user manual is a part of the equipment. It must be kept close to the equipment and be accessible at all times for all users. Should the equipment be passed on to a third party, the manual must also be passed on to the third party.

1.2 Symbols used in this manual

Issues relevant to safety are characterized in this manual according to the following symbols. These warnings must be observed in order to operate the equipment safely and avoid accidents, damage or injury.

Risk of serious or fatal injury:



This symbol alerts the user to potential serious or fatal injuries. Do not operate the equipment until you have completely understood the instructions and proceed accordingly.

Risk of electric shock:



This symbol alerts the user to the presence of un-insulated electric power that has the potential to cause serious or fatal injuries. Do not operate the equipment until you have completely understood the instructions and proceed accordingly. All maintenance work must be performed by qualified service personnel.

Important note:



This symbol alerts the user to potential sources of malfunctions or damage to the equipment if operated improperly.

Important reference to the manual:



It can be dangerous to undertake work on those parts of the system, labeled by this symbol, unless the manual has been read and understood.

Advice:



This symbol alerts the user to advice on efficient and trouble-free operation.

1.3 Liability and warranty

The manufacturer of this product has many years of experience and expertise in the field of water treatment technology. This manual has been written based on current safety code legislation and state-of-the-art technology.

The user manual must be kept close to the equipment and available at all times for anyone intending to use the equipment.

The user manual must be read before any work is carried out using the equipment! The manufacturer does not accept liability for damage or faults that arise due to disregard for the instructions in the manual.

The text and diagrams depicted in this manual do not necessarily match the equipment you have received. The diagrams and images are not on a scale of 1:1.

The equipment delivered to you may be slightly different to the equipment described and depicted here due to special features, additional options or changes in technology. If you have any questions, please contact the manufacturer.

We reserve the right to make technical changes to the product and further develop it in order to improve its functionality.

1.4 Copyright

This manual must be treated as a confidential document. It is only intended for use by those operating the equipment.

All contents of this manual – text, diagrams, images etc. – are protected by copyright law and industrial property rights. Anyone found violating these rights will be prosecuted.

The manual may not be passed on to third parties, copied – either in part or whole – or used for any other purpose without the express and written consent of the manufacturers. Anyone found violating these copyright laws must pay compensation. The manufacturer may also prosecute.

We reserve the right to exercise all industrial protection rights.

1.5 Spare parts

Only use original spare parts supplied by the manufacturer.



The wrong or faulty spare parts can lead to damage, malfunction or a complete breakdown of the equipment.

All guarantees, warranties, service, damage and liability claims against the manufacturer, the manufacturer's representatives and dealers become null and void if unauthorized spare parts are used in the equipment.

1.6 Disposal

If no return or disposal contract has been agreed on, please dispose of the disassembled components as follows:

- Recycle scrap metal parts,
- Recycle plastic parts,
- Dispose of other components according to the material.



Electrical and electronic scrap and components, lubricants and other process materials must be treated as hazardous waste and can only be disposed of by authorized waste disposal facilities.

2 Safety

At the time this equipment was developed and produced, it complied with current state-of-the-art technology and is accepted as reliable and safe.

The equipment can represent a hazard if it is operated by untrained personnel. Improper operation or operation not in accordance to the manual may pose a hazard.

The section on safety provides an overview of all the important issues relevant to personal safety and safe, trouble-free operation of the system.

The other sections of the manual also contain specific safety warnings and warning symbols that highlight possible hazards. Please comply with the pictograms, signs, markings and inscriptions on the equipment. These must not be removed and must always be visible.

2.1 Intended use

The equipment is only safe if operated as intended and described by the instructions in this manual.



Any form of use or operation other than the intended use is improper and prohibited.

Claims of any kind made against the manufacturer or the manufacturer's representatives are null and void if the equipment is not operated as intended.

The operating company is liable for all damages caused by improper use.

The intended use is described in the manual and includes compliance with the operating conditions.

The equipment may only be operated with the parts supplied.

2.2 Contents of this manual

Anyone intending to work with or use the equipment must read and understand the user manual before operating the equipment. This applies even if the user has already operated similar equipment or devices of a similar nature or has been trained by the manufacturer.

Reading and understanding the manual is the only way to protect against potential hazards, prevent mistakes and operate the equipment safely and efficiently.

We recommend that the operating company obtain written confirmation from each user that he/she has read and understood the manual.

2.3 Changes and modifications to the equipment

In order to avoid hazards and ensure that the equipment operates at its best, do not make any changes or modifications to the equipment that have not been expressly authorized by the manufacturer.

Ensure that all pictograms, signs, markings and inscriptions on the equipment are always visible and never removed. Damaged, missing or illegible pictograms, signs, markings and inscriptions must be replaced immediately.

2.4 User responsibility

The user manual must be kept close to the equipment and available at all times for anyone intending to use the equipment.

The equipment may only be operated in a technically flawless and safe state. The equipment must be checked for damage before each start-up.

The instructions in the manual must be followed completely and without restriction!

When operating this equipment, it is essential that the user adhere to the safety and operating instructions provided. The local accident prevention regulations, general safety regulations and relevant environmental protection legislation must also be followed.

The operating company and the authorized personnel within that company are responsible for properly operating the equipment. The operating company must define who is responsible for installing, operating, servicing and cleaning the equipment.

The operator is obliged to perform an operations manual. Otherwise the warranty expires.

2.5 Personal requirements

Only authorized and trained personnel are allowed to operate the equipment. The user must have been instructed about the potential hazards involved in using the equipment.

Authorized personnel are persons with sufficient training, knowledge, experience and understanding of the relevant regulations to be able to assess the task given to him/her and identify potential hazards.

If a potential user does not have sufficient knowledge at his/her disposal, this person must be trained/qualified before using the equipment.

It must be clear who is responsible for equipment installation, operation, maintenance and service. These competencies must be clearly defined and conformed to in order to prevent any uncertainties that may compromise safety.

Only reliable personnel may work with and operate the equipment. Do not allow anyone to operate the equipment in a way that compromises the safety of others, poses a hazard to the environment or damages the equipment.

No one under the influence of drugs, alcohol or medication that impairs the ability to respond/react is allowed to operate the equipment. Please consider all other directives related to qualification when selecting potential users.

The user must ensure that unauthorized personnel keep a safe distance from the equipment.

Personnel must report to the operating company immediately if any changes become apparent which may impair the safe operation of the equipment.

2.6 Health and safety work

Follow the safety and operating instructions given in this manual in order to avoid causing harm or damage to persons and property while working with and on the equipment. If these instructions are not observed, the equipment may become damaged or destroyed or may harm persons.

The manufacturer is not liable for damage or compensation if the safety and operating instructions in this manual or the local accident prevention regulations and general safety regulations are not observed.

2.7 Personal protective equipment (PPE)



When working with this equipment, please wear goggles or another form of protective eyewear.

2.8 Potential hazards

The subsequent equipment design and execution corresponds to state-of-the-art technology and regulations at the time of manufacture.

The equipment is safe for use, provided it is operated as intended. A minimal residual risk cannot be eliminated completely.

The equipment is run at high electrical voltage.



Electricity in the equipment can lead to serious injuries. The equipment presents a danger to life if the insulation or individual components become damaged.

Switch off the main power switch before carrying out maintenance, cleaning or repair work and ensure that it cannot be switched on again while carrying out this work.

Eliminate all voltage from the equipment when working on the electrical equipment.
Do not remove or deactivate any safety equipment.

The manufacturer does not take any responsibility for injuries caused by improper use of the system.

3 System Features

3.1 General

The *Aquinity*² system is designed for the production of analytical grade ultra pure water from drinking water public municipal supply. The system combines the advantages of reverse osmosis with final purification. Permeate from the reverse osmosis is temporarily stored inside of an integrated tank. In a purification section ultra pure water with permanent highest quality will be produced, supplied with the dispenser at the front side of the unit.

Currently recorded data and warning messages will be displayed on the system monitor.

All components of the system are assembled in a designed plastic housing. The housing can easily be opened for the access of the modules. The system corresponds to the latest technology and to recent safety regulations. It can be installed and put into operation without the help of customer service.



Figure 1: *Aquinity*² P10

3.2 Series overview

<i>Aquinity²P10</i> model	UV-reactor	Art.-No.:
Reagent	○	114-0070
Analytical	●	114-0071

Table 1: Series-overview

3.3 Technical data

<i>Aquinity² P10</i>		RE	AL
Product water specifications			
product water flow	L/min	up to 2	
conductivity at 25°C	µS/cm	0,055	
resistivity at 25°C	MΩcm	18,2	
TOC-concentration	ppb	< 10	< 3
System specifications			
shipping weight	kg		
power supply	V	100 ... 240	
	Hz	50 / 60	
dimension (W/D/H)	cm	35 / 54 / 51	
dimension +dispenser (W/D/H)	cm	35 / 75 / 63	

Table 2: Technical Data

3.4 Purification process

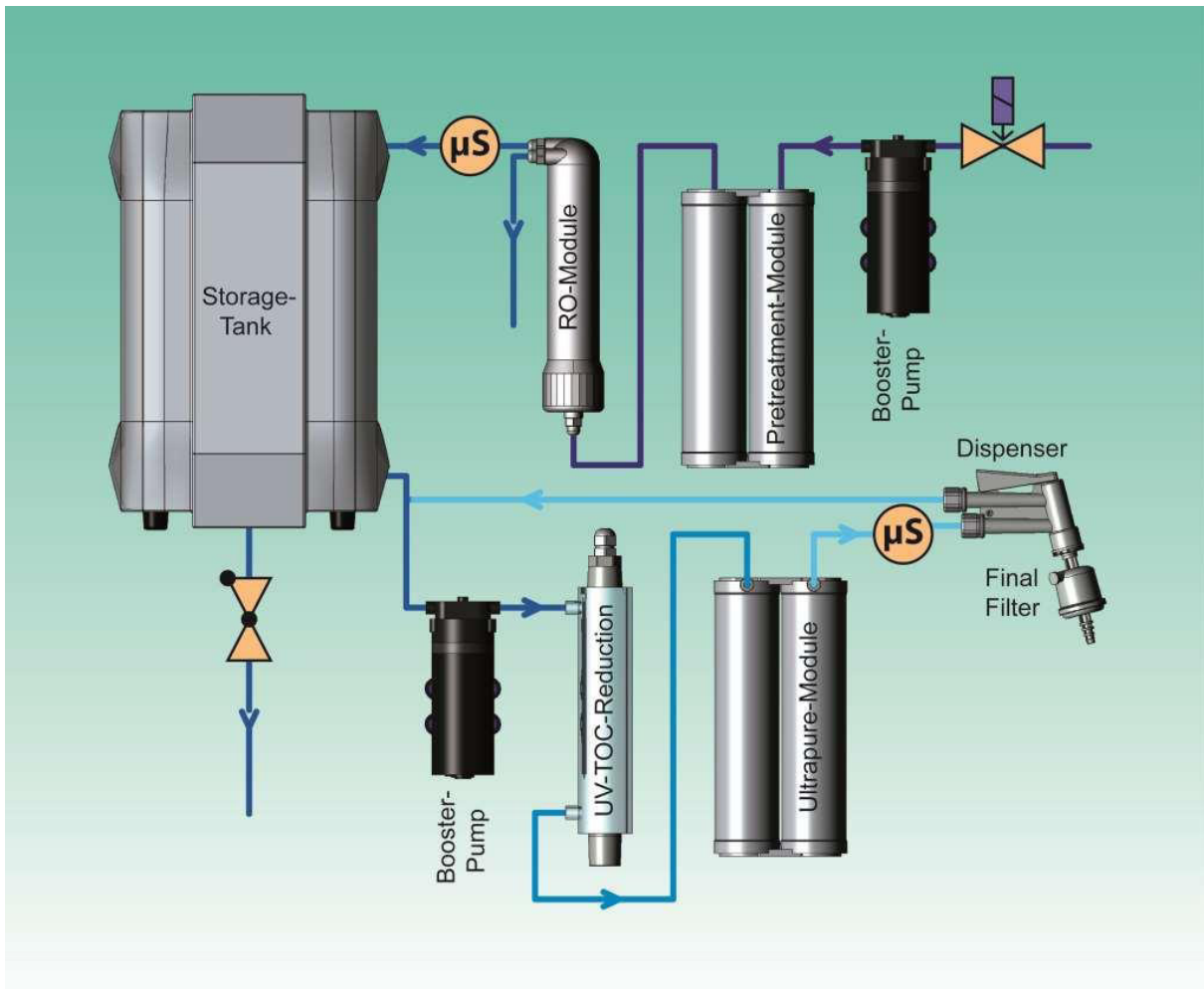

Figure 2: purification diagram

When the system is started in normal operation mode, the inlet valve opens and the reverse osmosis pump starts. It will be closed and the pump will be stopped, when the permeate tank is completely full.

The pretreatment module ProPak-R10 is a combination of filtration and adsorption via highly pure activated carbon. Chemicals like chlorides, insecticides, pesticides, and herbicides and particles larger than 5 micrometer are detained.

The RO pump increases the pressure for the reverse osmosis process. The reverse osmosis module remove about 98% of the salt content from the water. Moreover nearly all bacteria, viruses, heavy metal complexes as well as organic molecules with a molecular weight higher than 300 daltons are rejected. The purified water is called permeate, the waste reject water is called concentrate. The concentrate water is rejected to drain via flow limiter.

The permeate conductivity is monitored with a sensor and displayed on the system monitor. The measured value is displayed in the unit $\mu\text{S}/\text{cm}$. If the conductivity exceeds a preset limit, a warning message will be displayed and the permeate will be drained.

The system is connected to a tank with level control to regulate the production and tank filling. When the tank is completely full, the production will be stopped. When the level falls below the lower limit, the production will be started again and the tank will be filled.

The tank will be vented with sterile air via ventilation filter.

The circulation pump feeds the water into the polishing section with circulation.

UV systems only: Inside the UV reactor free hydroxyl radicals (OH \cdot) are produced. These radicals oxidize remaining organic materials in the water.

The polisher module UPW-Pak Art.-No.: 190-0087 is filled with high grade mixed bed resins in semiconductor quality to reduce mainly the salt content. For inorganic applications which do not require a low level TOC the polisher module UPW-Pak Art.-No.: 190-0088 can be used.

Product water conductivity is monitored with a sensor and displayed on the system monitor. If the conductivity exceeds a preset limit, a warning message will be displayed.

A sensor monitors the temperature of the product water. If the temperature exceeds the limit of 40°C, a warning message will be displayed.

The sterile filter protects the system against microbial contamination by filtration of particles larger than 0.2 μm .

Product water will be supplied via dispenser. For a small volume of product water the dispenser button has to be pressed slightly, for a higher volume the dispenser can be switched into permanent position.

A check valve keeps the circulation pressure constant and prevents a backflow of the product water.

3.5 Hardware

3.5.1 Dispenser



Figure 3: Standard dispenser

The dispenser has a lock function to make water tapping easier. Moreover, the dispenser will stay in a fixed position which has increased its flexibility (no draw back function) and gives the user more comfort when tapping water. This has been set as a standard dispenser for pure water system and memtap system (optional).

3.5.2 Control PCB

Water system has a control pcb which provides communication between main computer system and analog- & digital-sensors. This pcb has been flashed with a firmware (Firmware-Version 0.13.8) with a watchdog function. If there is any problem with sensor reads, this control pcb will restart the system automatically after ca. 2 minutes.

3.5.3 IEC Socket



Figure 4: Universal IEC-socket

The system is provided with a power cable with an IEC socket. This socket is a universal socket which has been used in the most electronic-devices (PC, monitor, etc.).

3.5.4 Front- and side-panel

In the front panel , there is a USB port which can be used either to backup files or update system with a new software and firmware. And there is also a small reset button which can be used to restart the system manually.

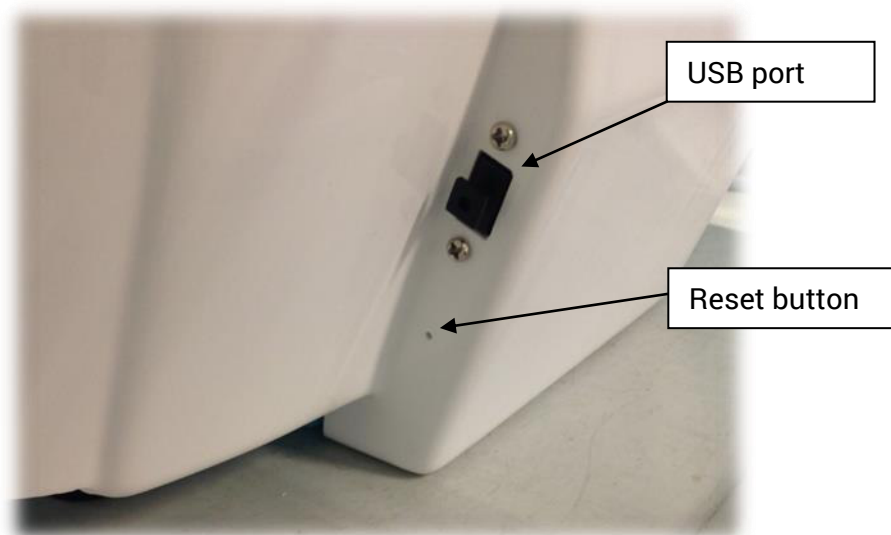

Figure 5: Front panel

There are eight magnetic holders (4 each side) to hold the panel which covers both side of the system. This side panel could be opened when it is needed in order to change consumables.



Figure 6: Side panel with magnetic holder

4 Installation and start up

4.1 Feed water requirements

All given flow rates are based on feed water temperature of 10°C (50°F). The RO permeate flow will change approx. 2% for each °C (decrease for lower values, increase for higher values).

pressure	bar	1,5 ... 6	
max. Flow	L/h	80	
feed water conductivity	µS/cm	< 1400	
free chlorine	mg/L	< 0,1	
CO ₂	mg/l	< 15	concentration total < 20
silica	mg/l	< 10	
Silt Density Index (SDI)		< 3	
iron	mg/l	< 0,1	
manganese	mg/l	< 0,05	
pH		3 ... 9	
temperature	°C	5 ... 25	

Table 3: Feed water requirements

4.2 Delivered parts







 <p>Watersystem 114-0070 / 114-0071</p>	 <p>Pretreatment module ProPak-R10 290 - 0065</p>	 <p>Polisher module UPW-Pak 190-0087 / 190-0088</p>	 <p>Sterile filter 190-0013</p>
 <p>Ventfilter 450-0025</p>	 <p>Tube to system</p>	<p>3x tube to drain</p>	

Table 4: Delivered parts

4.3 Setting up the system

The system is intended for dry indoor use only. Please set the system upon an even, horizontal surface. The surface must be resistant to applied chemicals like disinfectant, acid, dye, solvents etc.

4.4 Sealing plug

In- and outlets of the device are sealed with plugs to prevent leaks during delivery. Before connecting the system to the water supply and waste water drain, remove the plugs from the tube connectors on rear side of the device. Lightly depress the fastening ring and gently remove plug.

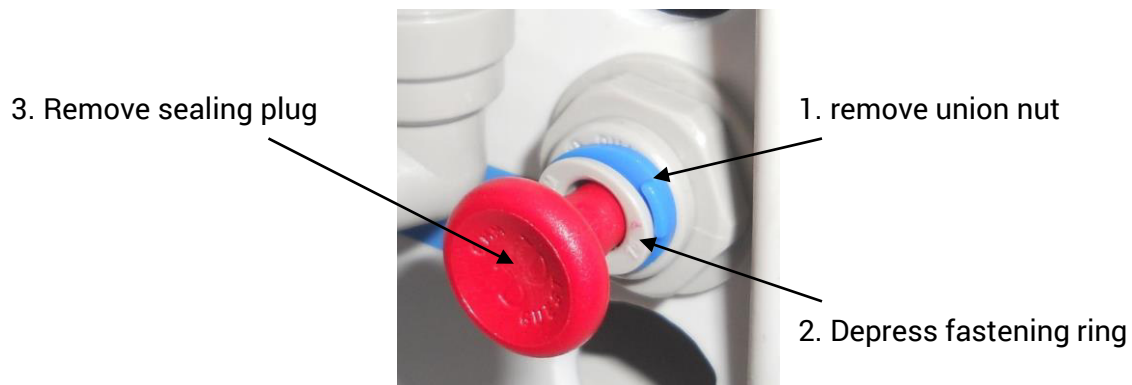

Figure 7: Sealing plug

4.5 Connections

All waste tubes must be led with a downward gradient toward the waste water drain. Any reduction of the diameter, loops, siphons or breaks in the line must be avoided.

A minimum safety distance of 2 cm (3/4-inch) must be between tube end and waste water to prevent siphoning. An air gap of a minimum distance of double inner tube diameter is recommended.

- Plug the tubes in until stop position. The tube must bottom out in connector. Tubes have to be locked with the union nut.
- Connect the tubes correspondently to their markings and push them to the stop.

4.6 Module attachment

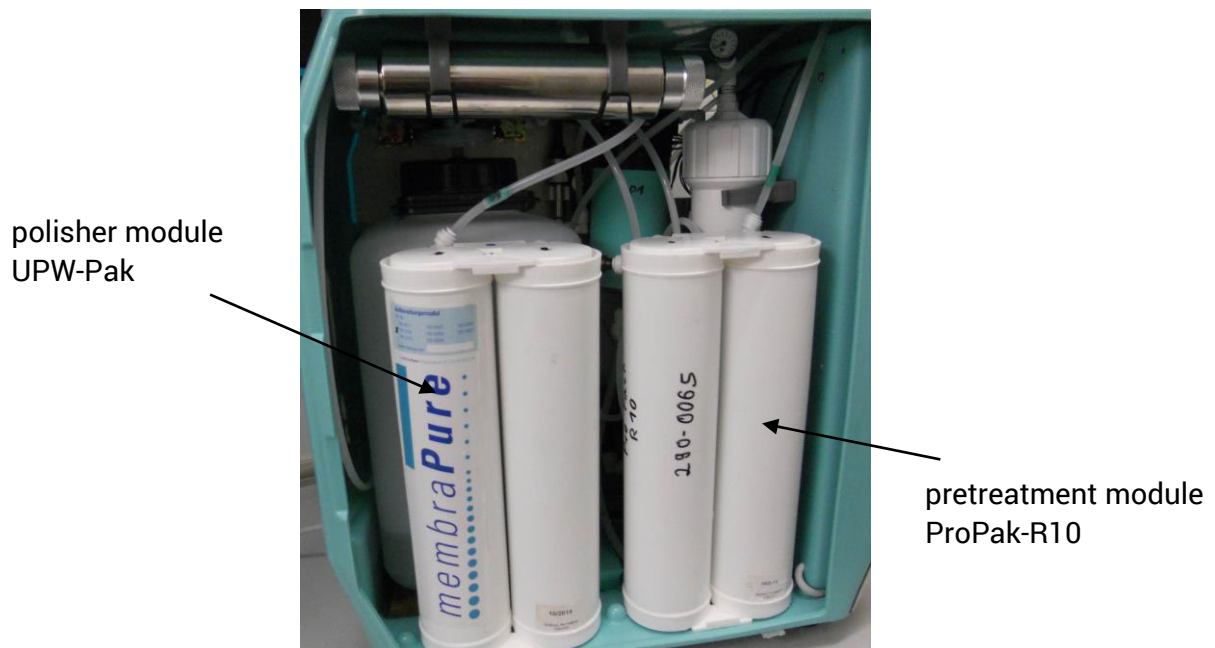

Figure 8: Modules

- Open the side panel.
- Connect the tubes correspondently to their markings and push them to the stop. Tubes have to be locked with the union nut.

4.7 Vent filter attachment



Figure 9: Vent filter

- Unpack the vent filter
- Attach the vent filter to the filter socket on the tank cap.

4.8 Sterile filter attachment

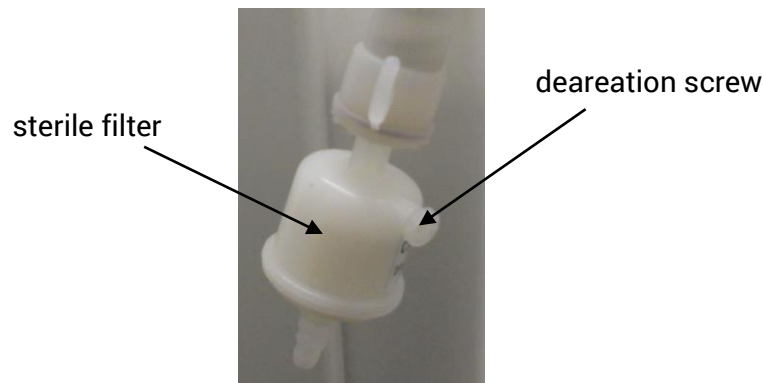

Figure 10: Sterile filter



Install the sterile filter with caution to avoid damage to the filter or to the device!

- To avoid any leaks, wrap the threads of the sterile filter with teflon tape.
- Attach the sterile filter at the dispenser of the device by turning the sterile filter clockwise in the dedicated headset.

4.9 Electrical connection

- Plug the power adapter into an electrical outlet (100 ... 230 volts, 50/60 Hz).



all electrical wiring must be installed in the way that damaging by work carried out in the environment of the system is impossible

5 System Control Panel

5.1 Normal operation mode

If the *Aquinity² P10* is connected to power supply, the system jumps in normal operation mode automatically. By default, the main information screen is displayed. The entire process is fully automatic controlled.

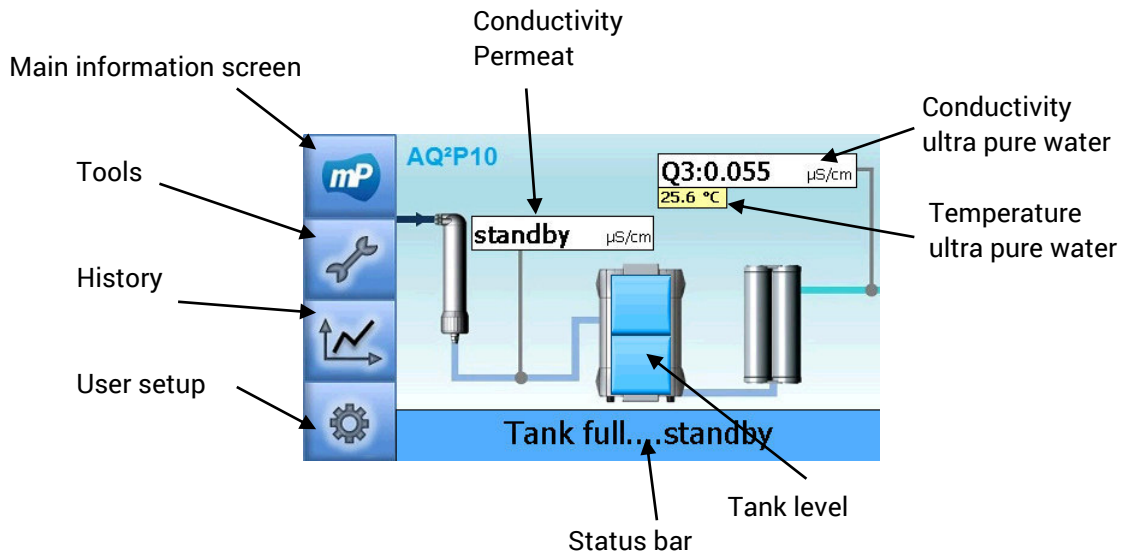

Figure 11: main information screen *Aquinity² P10*

5.2 Tools

In „Tools“ it is able to use functions for consumables replacement or process visualization.

5.2.1 Exchanging consumables

These following steps are used to change either ProPak or UPW-Pak. The steps are similar for both consumables. But they have different internal process in the system, which runs automatically.

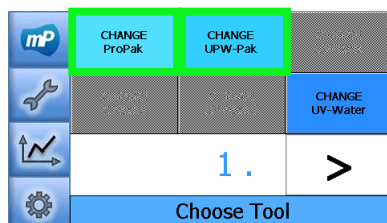

- Press the button "CHANGE ProPak" or press the button "CHANGE UPW-Pak"

System Control Panel

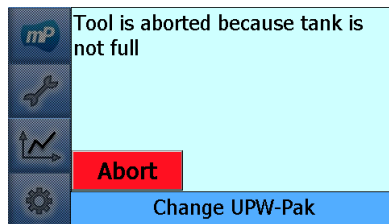

- Tank level should be full to change the UPW-Pak. If tank level is not full, the tool aborts automatically.

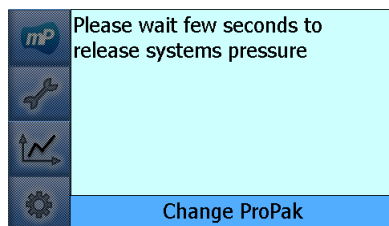

- If the tank level is full, it will release system pressure for few seconds

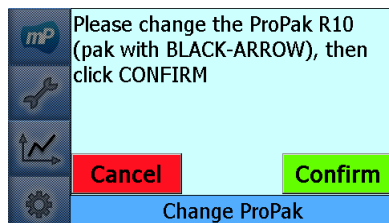

- Change the requested Pak;
 - o ProPak is the one with black arrow
 - o UPW-Pak is the one with blue arrow

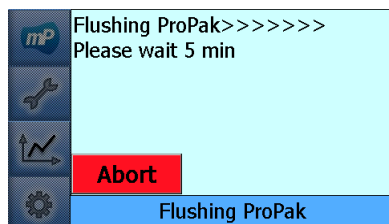

- Waiting 5 minutes to flush the new installed Pak

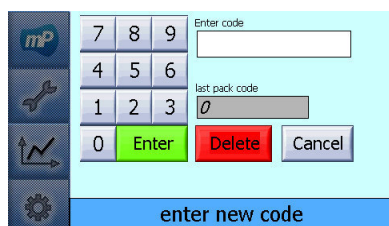

- To reset the operation hours please enter the code which is provided by *membraPure* GmbH
OR
- This step could be skipped (by clicking "cancel"), but the operation hours is not resetted to zero

5.2.2 Exchanging UV-lamp (in the pure water section)

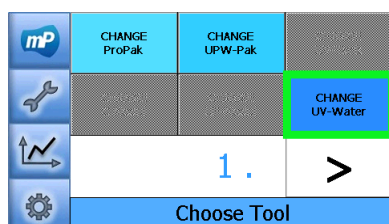

- Press "CHANGE UV-Water" to start the tool

System Control Panel

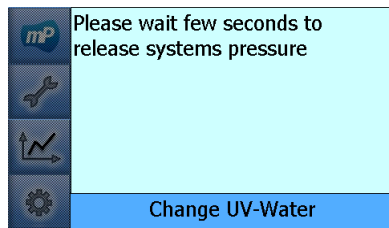

- Waiting few seconds to release system pressure

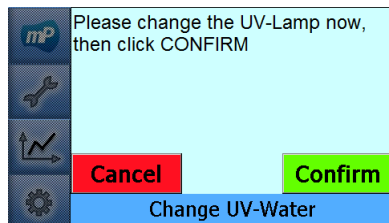

- Exchange the UV lamp (see also chapter 6.4), then click Confirm

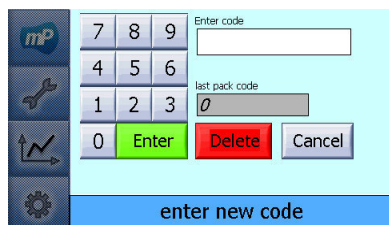

- To reset the operation hours please enter the code which is provided by *membraPure* GmbH

5.2.3 Change all Consumables

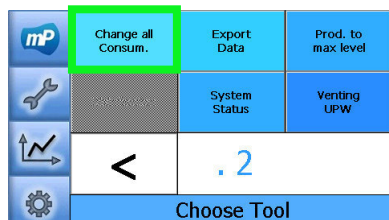

- Press the button "Change all Consumables"

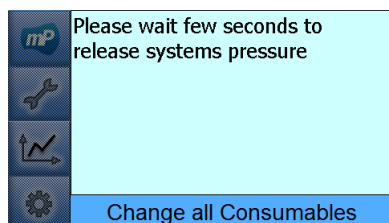

- Waiting few seconds to release system pressure

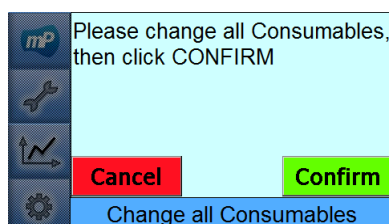

- Exchange all available consumables now, then click "Confirm"

System Control Panel

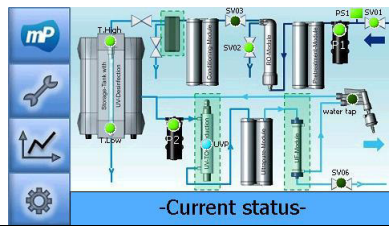

- The entire process is illustrated schematically. The state of all active components is displayed

5.2.7 Venting UPW

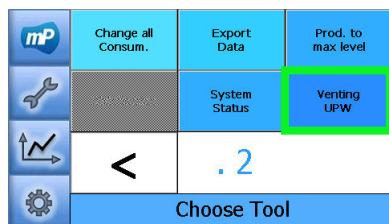

- Press the button "Venting UPW"
This is needed to vent the ultra pure water section from unwanted air in the system

5.3 History

The Aquinity² P10 has a recording function which stores values of the conductivity graphically or error messages.

5.3.1 Warning messages

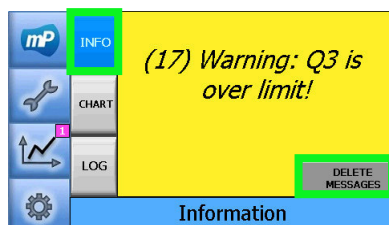

- Press the button „INFO“
- The history of active warning- / error messages is displayed
- Press the button "DELETE MESSAGES" to delete the active warning- / error messages



All warning- / error messages are still traceable in logfile (see chapter 5.3.3).

5.3.2 Graphical values

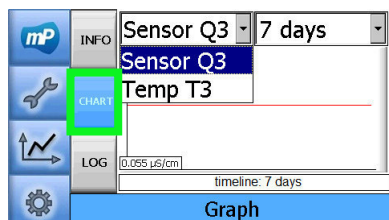

- Press the button „CHART“
- Define the time period at the scroll down menu which is located at the top right corner
- Select the conductivity sensor Q3 or temperature T3

System Control Panel

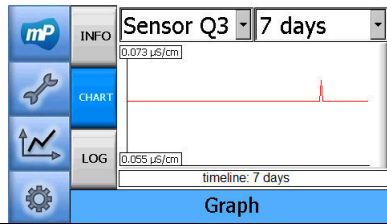

- The chart of the selected sensor will be shown.

5.3.3 Logfile

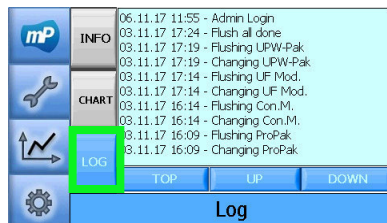

- Press the button „LOG“
- The logfile will be displayed

5.4 User setup

In user setup, for example, user-specific settings can be configured..



- To enter the user setup please enter the password 9999 and confirm entry with “OK”

5.4.1 Limits setup

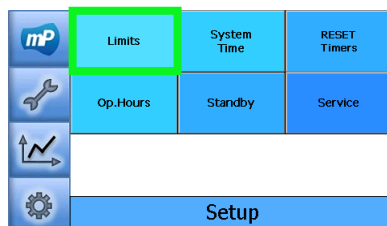

- Press the button „Limits“

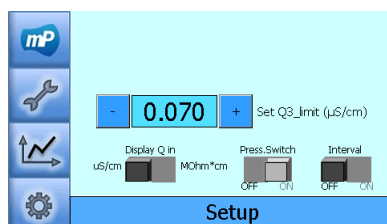

- Set Q3-limit: max. value of conductivity Q3 without showing any warning
- Conductivity can be displayed in two different ways (µS/cm or MΩ*cm)
- Press.Switch ON/OFF is to activate the monitoring of pressure sensor switch from feed water
- Interval ON/OFF is to define how the system works when the tank is already full

Interval ON: system recirculates every 3 hours
 Interval OFF: system recirculates permanently

5.4.2 System time settings

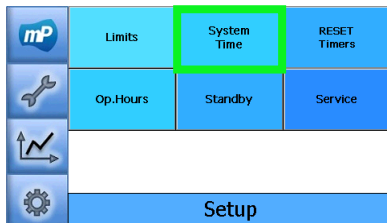

- Press the button „System Time”

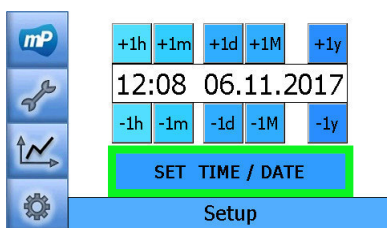

- The system time is shown in format *hh:mm*
- The date is shown in format *dd.mm.jjjj*
- Press the button “SET TIME / DATE” to save the entries

5.4.3 Reset timers(manually)

This setup can be used to reset timers of consumables and UV submersible lamps back to zero manually.

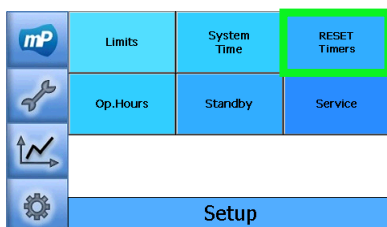

- Press the button „Reset Timers”

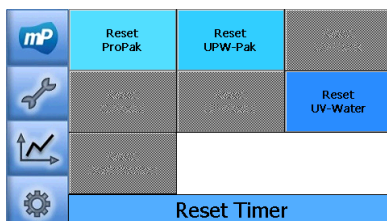

- Choose any consumables or UV submersible lamp, which should be set to zero (manually)

To reset the operation hours please enter the code which is provided by *membraPure* GmbH

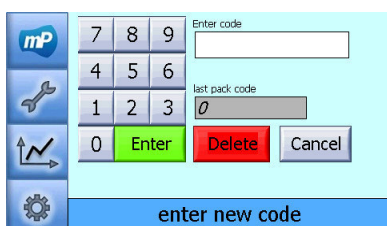

- To reset the operation hours please enter the code which is provided by *membraPure* GmbH

5.4.4 Operating hours

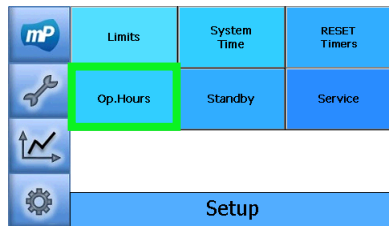

- Press the button „Op.Hours”

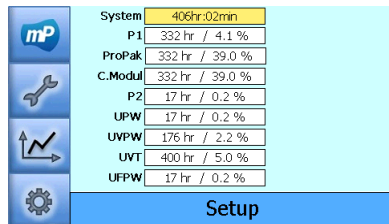

- This page show the lifetime of each components* of the system in hours and in %- of its lifetime.

*Components:

P1: Pump 1 // **ProPak:** pretreatment module //

C.Modul: Conditioning module // **P2:** Pump 2 //

UPW: polisher module // **UVPW:** UV-lamp in purewater //

UVT: UV-lamp inside tank // **UFPW:** UF-module in purewater

5.4.5 Manual stand by

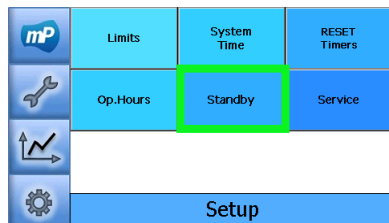

- Press the button „STANDBY”

The system will be put in stand by immediately

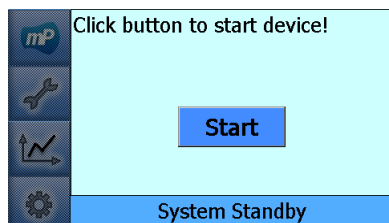

- The system will start the production again by pressing the “Start” button

5.5 Errors and Countermeasures

Display warning messages, their meanings and measures in order to eliminate them. If these measure do not contribute to elimination contact the customer service.

Trouble	Reason	Measure
(2) OPERATING HOUR LIMIT P1, Exchange recommended	Reverse osmosis pump exceeded the maximum operating hours.	Inform the customer service.
(4) OPERATING HOUR LIMIT P2, Exchange recommended	Circulation pump exceeded the maximum operating hours.	Inform the customer service.
(5) OPERATING HOUR LIMIT UPW-Pak. Exchange recommended	Polisher module UPW-Pak exceeded the maximum operating hours.	Replace the polisher module UPW-Pak. Reset the expired operating hours.
(6) Please change UV-lamp	UV-lamp exceeded the maximum operating hours.	Replace the UV-lamp. Reset the expired operating hours.
(8) Pump P1 error: Check pressure sensor!	No reverse osmosis-pressure can be registered for more than a half hour.	Check the main water supply Inform the customer service.
(11) Q1 is over limit! Check RO process.	Feed water quality is insufficient. Pretreatment module ProPak-R10 exhausted. Reverse osmosis function.	Check pretreatment. Replace the pretreatment module ProPak-R10. Inform the customer service.
(12) Water level is too low!	Product water tank is empty.	Wait for tank filling. Check the feed water supply. Check the system for leaks. Check the function of the RO process.
(13) No Pressure, check water input!	No feed water pressure.	Check the main water supply. Check the pressure sensor. Inform the customer service.
(15) Warning: T3 is over 40°C!	System temperature caused by UV lamp or recirculation pump too high.	Check Interval-Mode. Check the temperature of the environment and the feed water.
(17) Warning Q3 is over limit!	Q3 exceeds the limit.	Replace the polisher module UPW-Pack. Reset the expired operating hours.
(18) OPERATING HOUR LIMIT ProPak. Exchange necessary.	Pretreatment module ProPak-R10 exceeded the maximum operating hours.	Replace the pretreatment module ProPak-R10. Reset the expired operating hours.
(31) Tank level is incorrect! Please check tank level sensor!	Tank level sensor (-top) is ON, but (-bottom) is OFF. This could only possible if the bottom sensor is defect.	Inform the customer service.

Table 5: Display warning messages

Table 5: Display warning messages

6 Care and maintenance

6.1 Intervals

Measure	Intervall /Time	Alarm message	Reset required
Replacement of sterile filter	Every 3 month	none	no
Replacement of pretreatment module ProPak-R10	Every 2 – 6 months depending on feed water quality	LIMIT OPERATING HOUR "ProPak R10", Exchange necessary Q1 is too high!	yes
Replacement of polisher module UPW-Pak	Every 6 – 12 months recommended	LIMIT OPERATING HOUR "UPW-Pak", Exchange recommended Warning: Q3 is too high!	no
Replacement of UV-Lamp	after 8000 hours	TOC will be incorrect! Please change UV-lamp	yes
Replacement of reverse osmosis pump	after 2 – 4 years	LIMIT OPERATING HOUR "P1", Exchange recommended	yes
Replacement of circulation pump	after 2 – 3 years	LIMIT OPERATING HOUR "P2", Exchange recommended	yes
Replacement of reverse osmosis module	If blocked	Q1 is too high!	No
Maintenance by customer service	Every 12 months recommended	none	no

Table 6: Service intervals

6.2 Replacement of sterile-filter

Depending on feed water quality, ambient conditions and utilization germs are accumulated in the sterile filter and will contaminate the system.



Install the sterile filter with caution to avoid damage to the filter or the unit.

- Remove the old sterile filter by turning the sterile filter counterclockwise from the designated port.
- To avoid any leaks, wrap the threads of the sterile filter with Teflon tape.

- Attach the new sterile filter at the dispenser by turning the sterile filter clockwise in the dedicated port.
- At first water dispensing please open the deaeration screw for a short time to vent the sterile filter (see Figure 10: Sterile filter).

6.3 Modul replacement

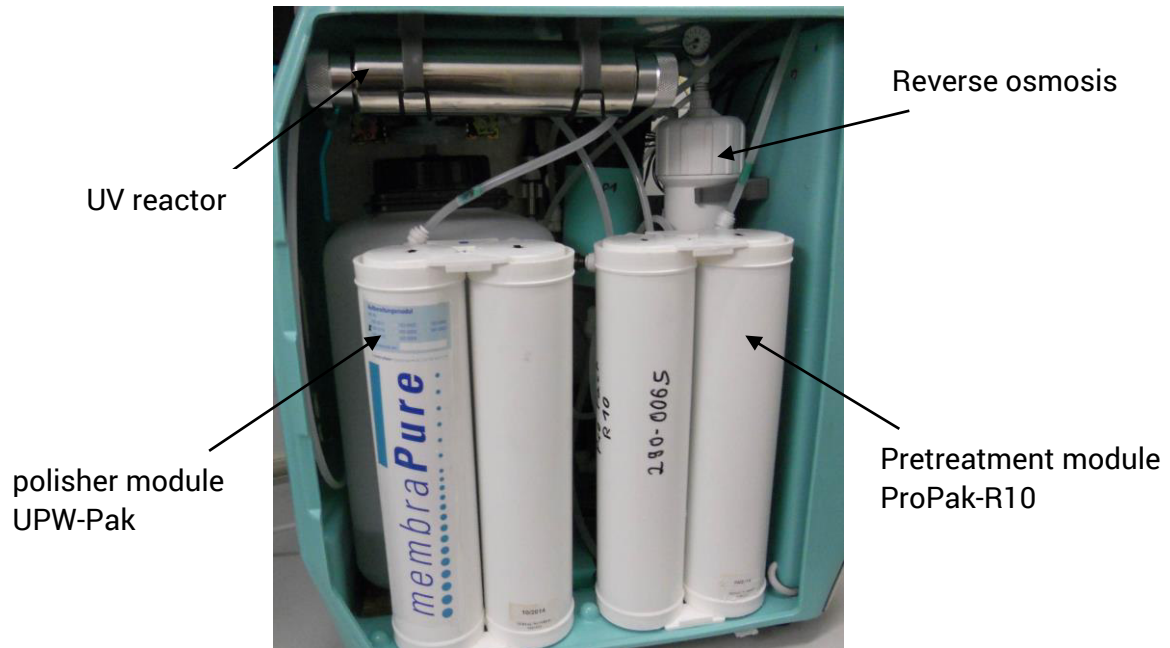

Figure 12: Modules in opened system

- Open the system.
- For exchanging of pretreatment module ProPak-R10 or polisher module UPW-Pak follow the steps listed in chapter 5.2.1
- For pulling off the tubes from the modules and plugging the tubes onto the new modules see chapter 4.4, 4.6
- After the flushing and resetting the operating hours counter, the system automatically jumps into normal operation.
- At first water dispensing please open the deaeration screw for a short time to vent the sterile filter (see Figure 10: Sterile filter).
- Check impermeability on all connections
- Close the front door, the system is ready for operation.



The highest ultra pure water quality is only reachable, if the resin is swollen. This should be completed within 24 hours after module replacement or first start.

6.4 Replacement of the UV-lamp

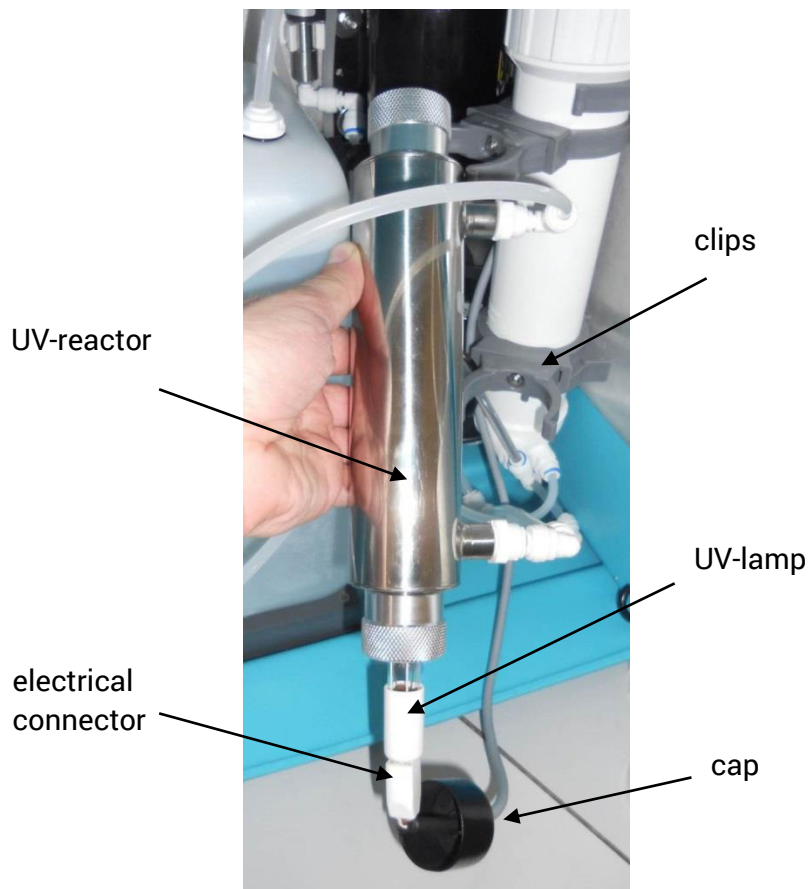

Figure 13: UV-lamp

- Turn off the system by unplugging the power adapter out of the electrical outlet.
- Open the system.
- Put the UV-reactor out of the clips.
- Loosen the UV-lamp by pulling the cap from the reactor.
- Disconnect the electrical connector from the UV-lamp and remove UV-lamp.
- Insert the new UV-lamp carefully without touching the glass with your fingers.
- Plug the electrical connector on the new UV lamp.
- Fix the UV-lamp with the cap.
- Put the UV-reactor into the clips.
- Close the front door.
- Plug the power adapter into an electrical outlet.
- Reset the operation hours counter. Please follow the steps in chapter 5.2.2 to do that.

6.5 Replacement of reverse osmosis module

- Turn off the system by unplugging the power adapter out of the electrical outlet.
- Disconnect the system from feed water.
- Open the system.
- Remove reverse osmosis housing from its holder.
- Remove tubes from the reverse osmosis housing (caution: water leakage).
- Open the housing and remove the reverse osmosis module.
- Unpack the new reverse osmosis module and put it into the housing.
- Close the housing.
- Reconnect the tubes onto the reverse osmosis housing.
- Plug the reverse osmosis housing back into its holders.
- Connect the system to feed water.
- Turn on the system by plugging the power adapter into an electrical outlet.
- Flush the reverse osmosis module by start the tool "CHANGE ProPak."
(see chapter 5.2.1).
- Check impermeability on all connections
- Close the front door, the system is ready for operation.

6.6 P&I scheme

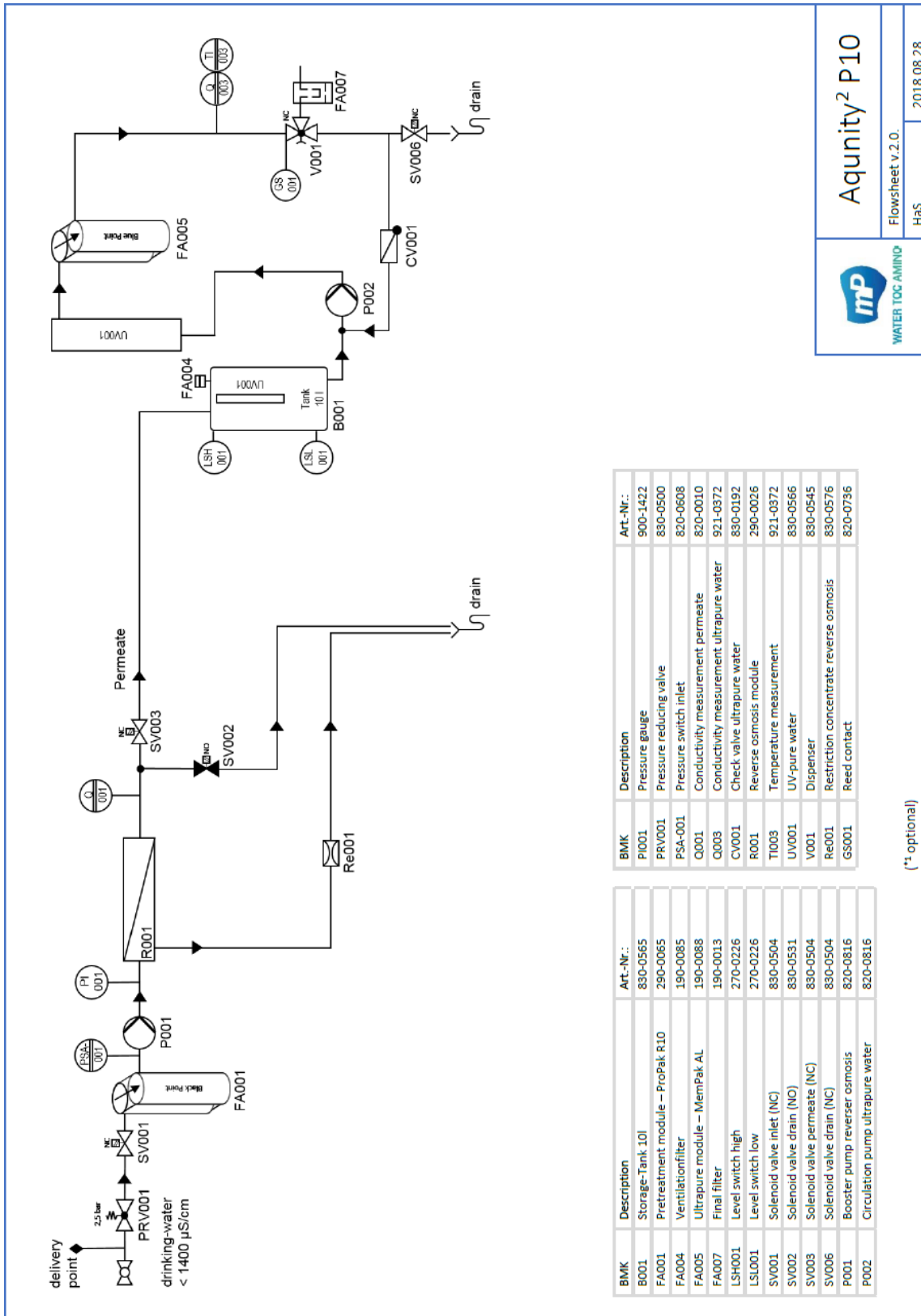

Aquinity² P10

Flowsheet v.2.0. 2018.08.28

BMK	Description	Art.-Nr.:
PI001	Pressure gauge	900-1422
PRV001	Pressure reducing valve	830-0500
PSA-001	Pressure switch inlet	820-0608
Q001	Conductivity measurement permeate	820-0010
Q003	Conductivity measurement ultrapure water	921-0372
CV001	Check valve ultrapure water	830-0192
R001	Reverse osmosis module	290-0026
TI003	Temperature measurement	921-0372
UV001	UV-pure water	830-0566
V001	Dispenser	830-0545
Re001	Restriction concentrate reverse osmosis	830-0576
GS001	Reed contact	820-0736

BMK	Description	Art.-Nr.:
B001	Storage-Tank 10l	830-0565
FA001	Pretreatment module – ProPak R10	290-0065
FA004	Ventilationfilter	190-0085
FA005	Ultrapure module – MemPak AL	190-0088
FA007	Final filter	190-0013
LSH001	Level switch high	270-0226
LSL001	Level switch low	270-0226
SV001	Solenoid valve inlet (NC)	830-0504
SV002	Solenoid valve drain (NO)	830-0531
SV003	Solenoid valve permeate (NC)	830-0504
SV006	Solenoid valve drain (NC)	830-0504
P001	Booster pump reverser osmosis	820-0816
P002	Circulation pump ultrapure water	820-0816

(*: optional)

6.7 Consumables

Description	Article no.
sterile filter	190-0013
pretreatment module ProPak-R10	290-0065
polisher module UPW-Pak (organic applications)	190-0087
polisher module UPW-Pak (anorganic applications)	190-0088
UV-lamp	921-0138
Tank ventfilter	450-0025

Table 7: Consumables

6.8 System update

In order to update the system with newer software, it requires a USB-Stick which is not bigger than 4 GB and should be formatted in .ext-Format. The new software should be available in the USB-Stick which formatted in .mip file.

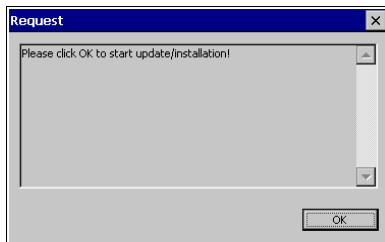

- Restart system with an available update in USB-Stick will open this window
- Click "OK" to continue

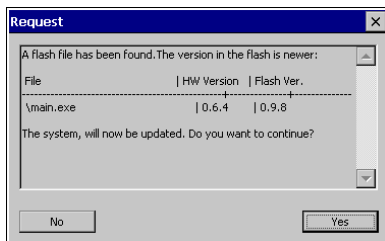

- Software-version will be displayed:
 - o HW-Version: actual in the system
 - o Flash Ver.: newer version in USB-Stick
- Click "Yes" to continue
- Click "No" will cancel the update request

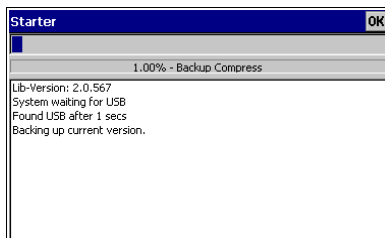

- System will update automatically. Please do not turn off the system.

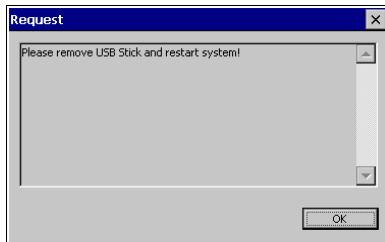

- System has updated the software
- Please remove the USB-Stick now
- Click "OK" to continue

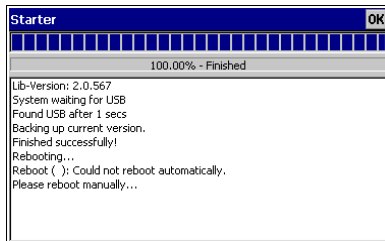

- Please restart the system manually
-

7 Users FAQ's

Q: How to change the maximum limit of conductivity sensors?

A: Max. limit of conductivity Q3 can be adjusted in the menu (see chapter 5.4.1)

Q: How to export charts & logs from my system?

A: See chapter 5.2.4. The charts and logs are encrypted

Q: How to update the software?

A: See chapter 6.8

Q: Conductivity values are often outside their working range, what to do?

A: Please check the water waste connection

8 Contact

membraPure GmbH
Wolfgang-Küntscher-Str. 14
16761 Hennigsdorf
Germany

Tel: +49-3302/201-20 0
Technical Service: +49-3302/201-20 20
Fax: +49-3302/201-20 21
info@membrapure.de
www.membrapure.de

9 Service setup

In service setup it is able to set limits, to change operating hours counters or load backup-datas of the configuration settings. Manual, functional switching of all actors is possible.



The service setup is password protected and only available for trained service technicians. Improper operation or incorrectly stored configuration settings may lead to malfunction or damage to the device

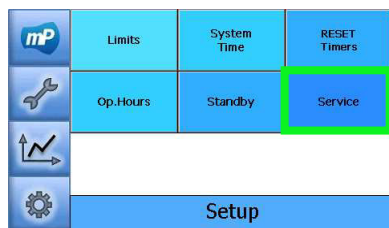

- Service setup is only available for service technicians from *membraPure* GmbH

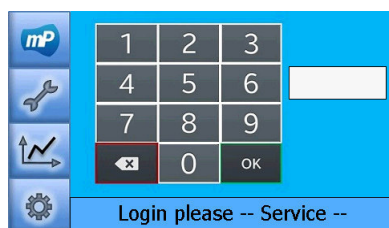

- To enter the service setup please enter the monthly generated password which is provided by *membraPure* GmbH and confirm entry with "OK"

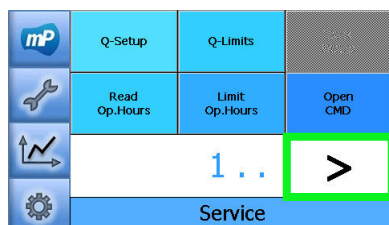

The service menu has three pages of sub-menus.

- Touch the arrow-keys which are located at the bottom of the screen to switch between the sub-menus.

9.1.1 Adjustment conductivity sensors Q and temperature T

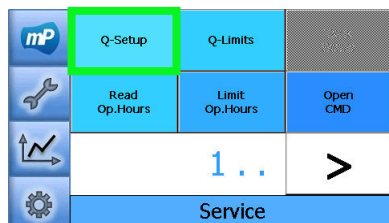

- Press the button „Q-Setup“

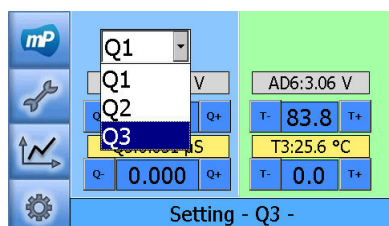

- Click the pull-down menu to choose the conductivity sensor

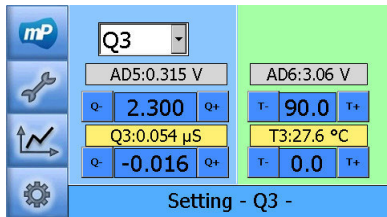

- Press the button “Q-” or “Q+” to change the scale-value of the conductivity measurement (upper value) or the offset (lower value)
- Press the button “T+” or “T-” to change the scale-value of the temperature measurement (upper value) or the offset (lower value)
- Entries change is saved automatically



The scale value is set in factory and should not be changed. The adjustment is done by using the offset normally. For more detailed calibration instructions please see chapter 9.2.1

9.1.2 Limit setting of conductivity sensors

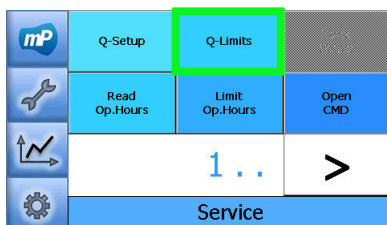

- Press the button „Q-Limits”

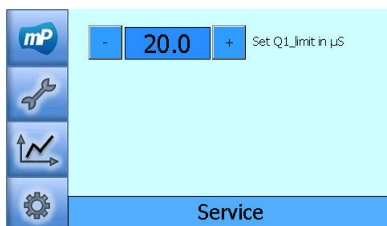

- Press the button “-” or “+” to shift the limit of conductivity sensors in µS/cm

Note: The unit of these conductivity limits is always shown in µS/cm

9.1.3 Read operating hours

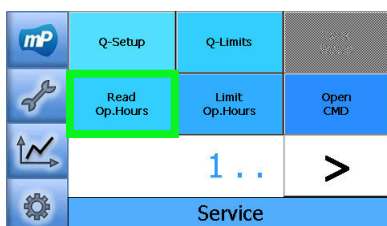

- Press the button „Read Op.Hours”

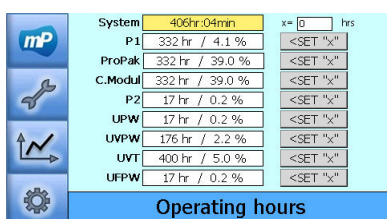

- This page shows the lifetime of each components* of the system in hours and in %- of its lifetime
- The entry “x= ___ hrs” can be changed manually with a keyboard
- “<SET “x”” can be used to set the component hours

*Components:

P1: Pump 1 // **ProPak:** pretreatment module //

C.Modul: Conditioning module // **P2:** Pump 2 //

UPW: polisher module // **UVPW:** UV-lamp in purewater //

UVT: UV-lamp inside tank // UFPW: UF-module in purewater

9.1.4 Limit operating hours

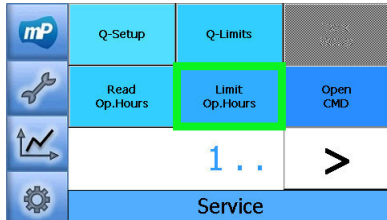

- Press the button „Limit Op.Hours”

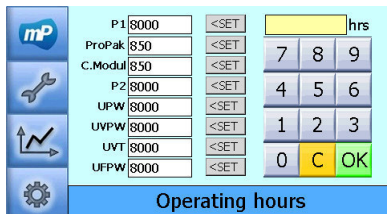

- This page shows the limit of each components lifetime in hours
- The entry “ ___ hrs” can be changed manually
- “<SET” can be used to set the component operating hours limits. Confirm with “OK”

*Components:

P1: Pump 1 // **ProPak:** pretreatment module //

C.Modul: Conditioning module // **P2:** Pump 2 //

UPW: polisher module // **UVPW:** UV-lamp in purewater //

UVT: UV-lamp inside tank // **UFPW:** UF-module in purewater

9.1.5 Command line

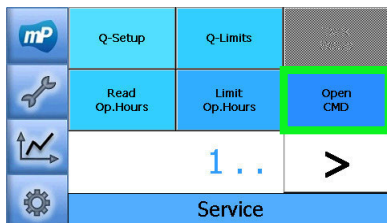

- Press the button „Open CMD”

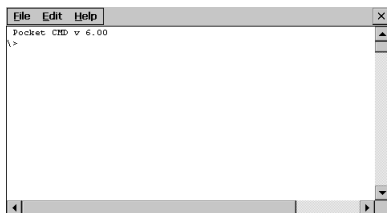

- This is the command line for the operating system. It can be used to interact with the system. Type “exit” or click the sign “x” on the top-right side of the display to go back to the service setup

9.1.6 System Info. (system-information)

The settings in this page define the appropriate device type. Furthermore, e.g. Informations of memory usage can be displayed.



This settings is only configurable for trained service technicians. Improper operation or incorrectly stored configuration settings may lead to malfunction or damage to the device

Service setup

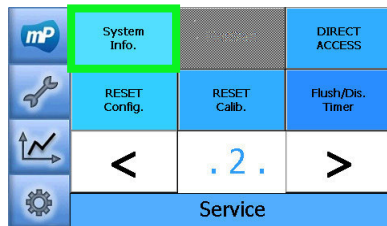

- Press the button „System Info.“

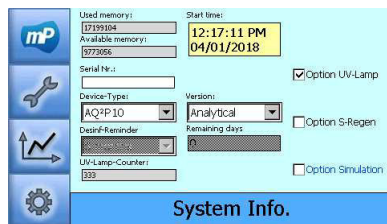

- This is where the options can be adjusted
 - Used memory: total memory used (in bytes)
 - Available memory: total memory available (in bytes)
 - Start time: time and dates of the system start working
 - Serial Nr: serial number of the system (should be set once)
 - Device-Type & Version: device system type (should be set once)*
 - Desinf-Reminder: total time to remind user of system disinfection
 - Remaining days: total days until the next disinfection notification
 - UV-Lamp-Counter: how many times the UVPW has been activated
 - Option UV-Lamp: activate the counter of UV-lamp (AL-System)
 - Option S-Regen: only for system with self-regenerating EDI cell
 - Option Simulation: to simulate system with constant values

*changing Device-Type will restart the system, so it is recommended to change the Version before the Device-Type

9.1.7 Direct access

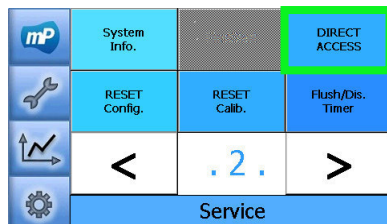

- Press the button „Direct Access“

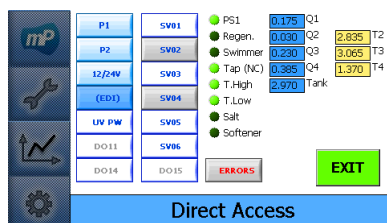

- This is a tool where each components functionality can be checked manually
 - o Actuators:
 - P1: pump 1 (input water)
 - P2: pump 2 (pure water)
 - 12/24V: voltage of P2
 - (EDI): electro-deionized cell (only *Aquinity²E*)
 - UV PW: UV-lamp in pure water
 - SV01~SV06: solenoid ventile 1...6
 - o Digital input:
 - PS1: pressure sensor of input water
 - Regen.: self-regeneration EDI-cell
 - Swimmer: overflow detector
 - NC: (normal-close) dispenser
 - T.High: tanklevel sensor (top) (only *Aq²P10*)
 - T.Low: tanklevel sensor (bottom) (only *Aq²P10*)
 - Salt: salt detector
 - Softener: softener detector
 - o Analog input:
 - Q1-Q4: conductivity sensor 1...4
 - T2-T4: temperature sensor 2...4
 - Tank (not available for *Aq²P10*)

9.1.8 Reset configuration

This tool is used to restore the initial configuration settings of the device.

Requirements: USB-stick with the *config.mcf* is plugged in the USB-port.

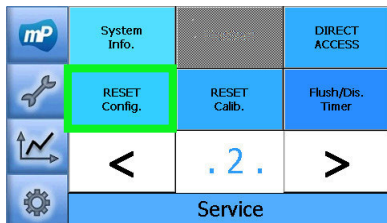

- Press the button „Reset Config.“

* Please make sure that there is a USB-stick (max. 4 GB, in FAT-format) connected to the USB-port!
-> copy files from **\Hard Disk\...** into **\Nandflash\...**

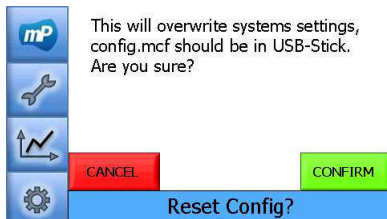

- This is a tool to load configuration settings of the device (all configuration-parameters are not adjustable in the software)

See chapter 5.2.4 about exporting data

9.1.9 Reset calibration

This tool is used to restore the initial configuration settings of the device.

Requirements: USB-stick with the *calib.mcf* is plugged in the USB-port.

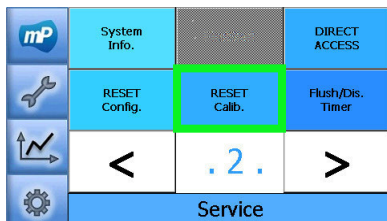

- Press the button „Reset Calib.“

* Please make sure that there is a USB-stick (max. 4 GB, in FAT-format) connected to the USB-port!
-> copy files from **\Hard Disk\...** into **\Nandflash\...**



- This is a tool to load calibration settings of the device (most calibration-parameters are adjustable in the software)

See chapter 5.2.4 about exporting data

9.1.10 Flushing, disinfection timer

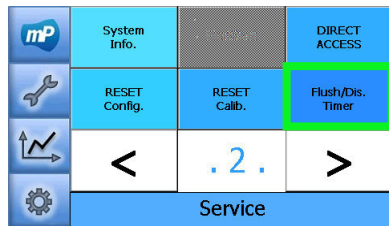

- Press the button „Flush/Dis. Timer”

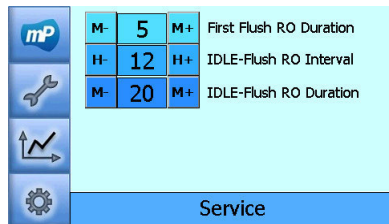

- This page shows the time-setting of:
First flush RO duration: duration of flushing RO
Idle-flush RO interval: interval of flushing RO (idle)
Idle-flush RO duration: duration of flushing RO (idle)

9.1.11 Editor .mcf-file

This tool is used to view and edit the configuration file (*config.mcf*) and calibration file (*calib.mcf*) in a simple text editor. There are several buttons to work with the editor:

Load Config. : show the configuration settings from *config.mcf* in the text editor
 Save : close and save the configuration settings into *config.mcf*
 Cancel : close the settings without saving any changes

Load Calib. : show the calibration settings from *calib.mcf* in the text editor
 Save : close and save the calibration settings into *calib.mcf*
 Cancel : close the settings without saving any changes



This settings is only configurable for trained service technicians. Improper operation or incorrectly stored configuration settings may lead to malfunction or damage to the device

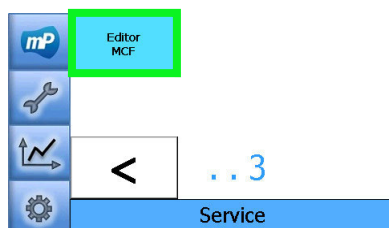

- Press the button „Editor MCF”

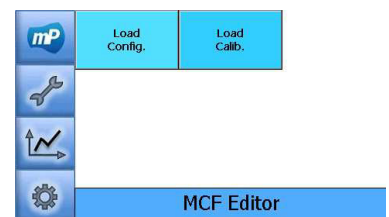

- This page shows the editor of *.mcf* file.
 There are two *.mcf* files;
config.mcf (Load Config.) & *calib.mcf* (Load Calib.)

Service setup



- This is the preview of configuration file (*config.mcf*)

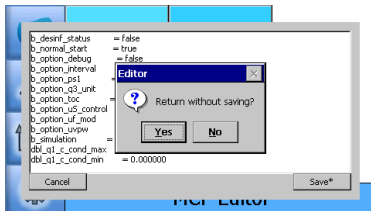

- This is the preview of calibration file (*calib.mcf*).
- If there was any change in the file, it should be saved
- By clicking “cancel”, the change could be discarded

9.1.12 Touchscreen calibration

In order to recalibrate the touchscreen, this can be done in the operating system setting for the stylus.

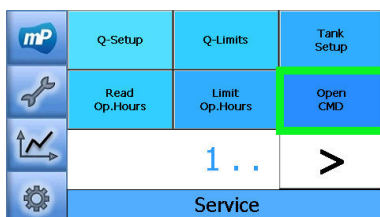

- Press the button „Open CMD” (see chapter 9.1.5)

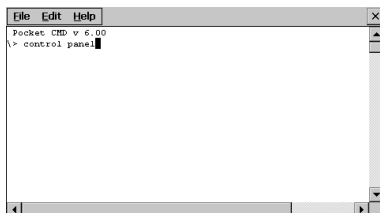

- Type “control panel” to open system settings



- Click “Stylus”

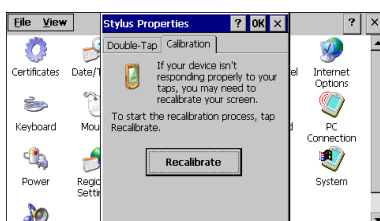

- Click the tab “Calibration”, then click the button “Recalibrate”

Service setup

Carefully press and briefly hold stylus on the center of the target.
Repeat as the target moves around the screen.
Press the Esc key to cancel.



- Follow the instruction to click five different targets. Then click anywhere to close the calibration setting. Then click “x” on the top-right side of the display to go back to service setup

9.2 Conductivity measuring amplifier

9.2.1 Calibration of the conductivity and temperature measurement

1. Adjust software settings for the conductivity- and temperature measurements with the electronics.



The reading values are sluggish as the values are based on averaging calculations (wait 20 sec. approx.). In principle first adjust the temperatures then the conductivities!

The scale value is factory set and should not be changed normally.

- Simulate conductivities and temperatures specified by resistors.
- Define the *scale value* of the temperature- and conductivity measurement so, that the temperature- and conductivity measurement shows the parameter which are simulated by the resistors.

Example adjustment of the measuring points Q1 and Q3 listed below:

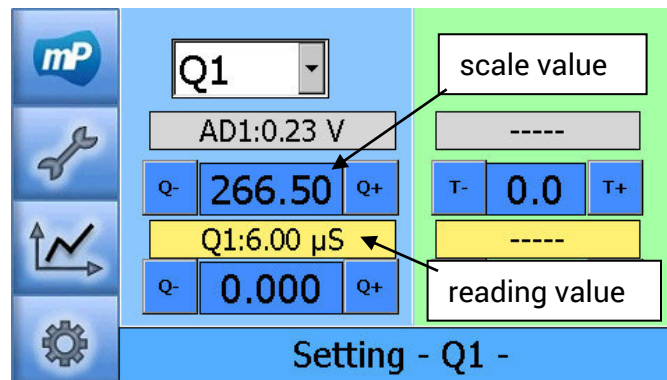

Resistor conductivity 100kOhm → 6 µS/cm

Resistor temperature non-existent, because Q1 uncompensated
(System must be in production, so that values are updated)

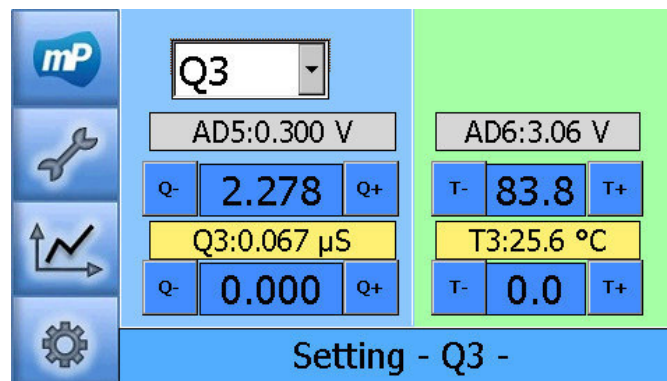

Resistor conductivity 150kOhm → 0,067 µS/cm

Resistor temperature 1,1kOhm → 25,6°C

(Ultra pure water part must be in recirculation, so that the values are updated)

- Adjustment of conductivity- and temperature measurement by direct comparison of the measurements with the WTW. Here regulate only the offsets, do not change the scale value anymore! Here deviations caused by measuring cells are compensated.

Q1 is shown uncompensated. Q2, Q3 and Q4 is shown temperature compensated (2% per Kelvin). Do the same settings on respective measuring point even on WTW.



Attention, the reading values are sluggish as the values are based on averaging calculations (wait 20 sec. approx.). In principle first adjust the temperatures then the conductivities!

Example adjustment of the measuring points Q1 and Q3 by offset listed below:

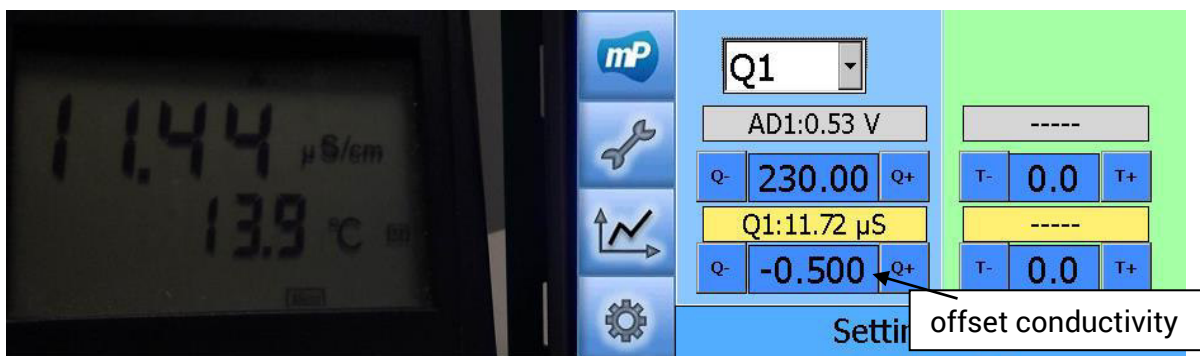

offset temperature non-existent, because Q1 uncompensated
(System must be in production, so that values are updated)

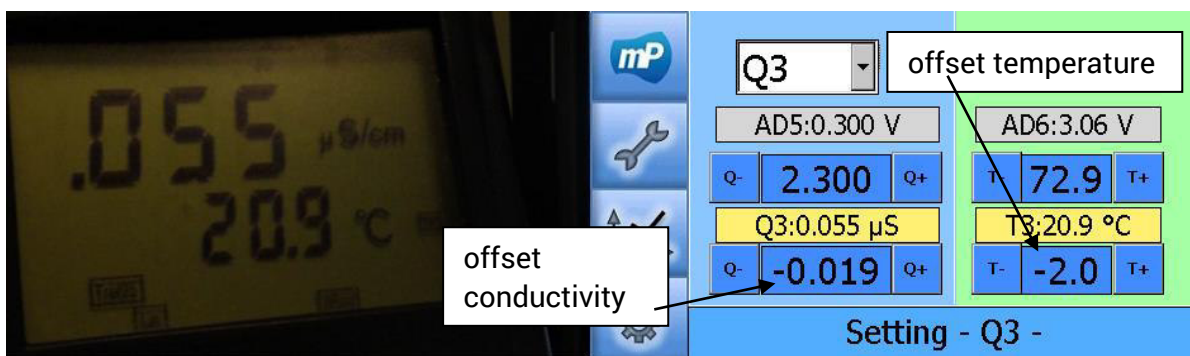

(System must be in recirculation, so that the values are updated)

9.3 Control board

CPU

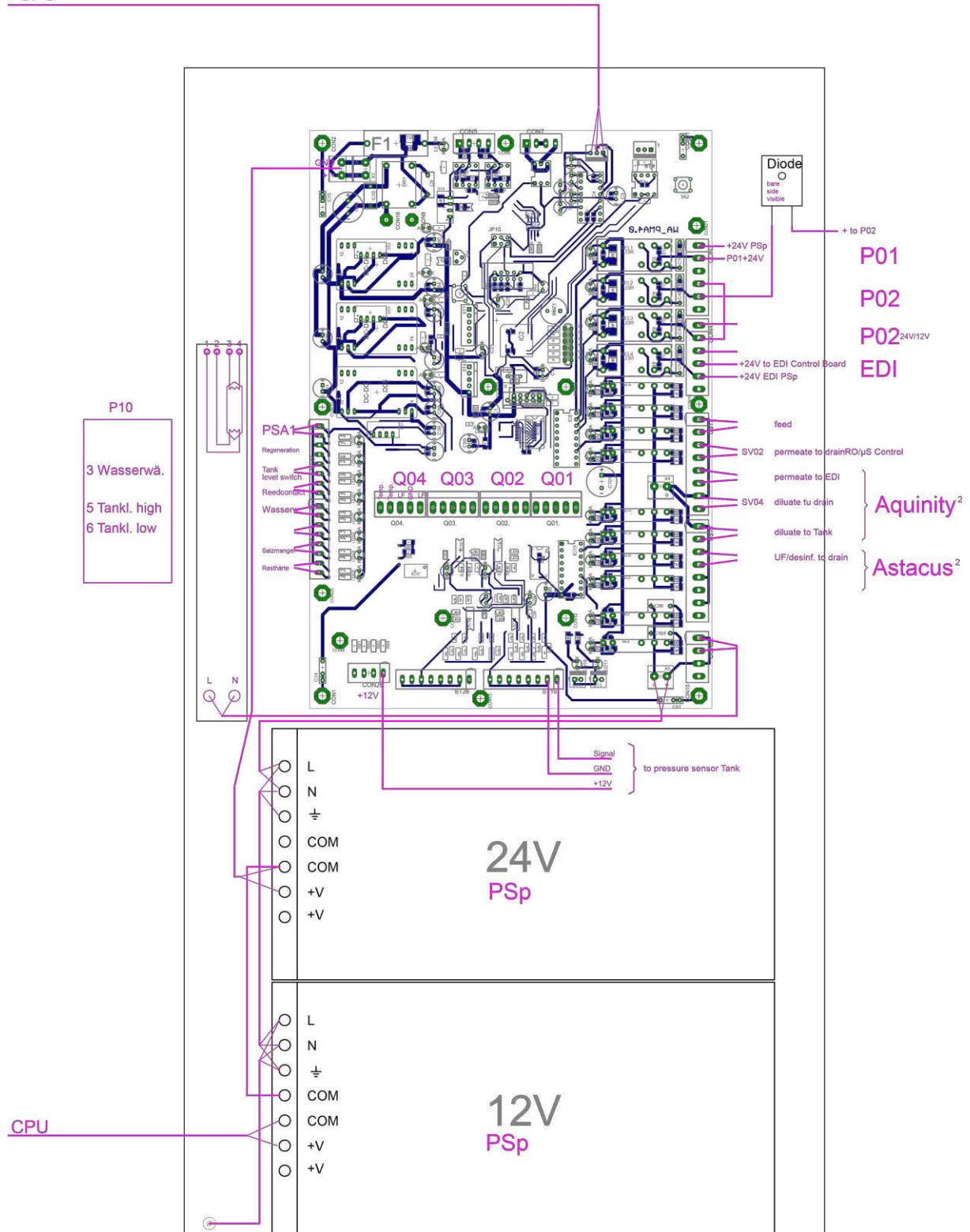

9.4 Single board computer

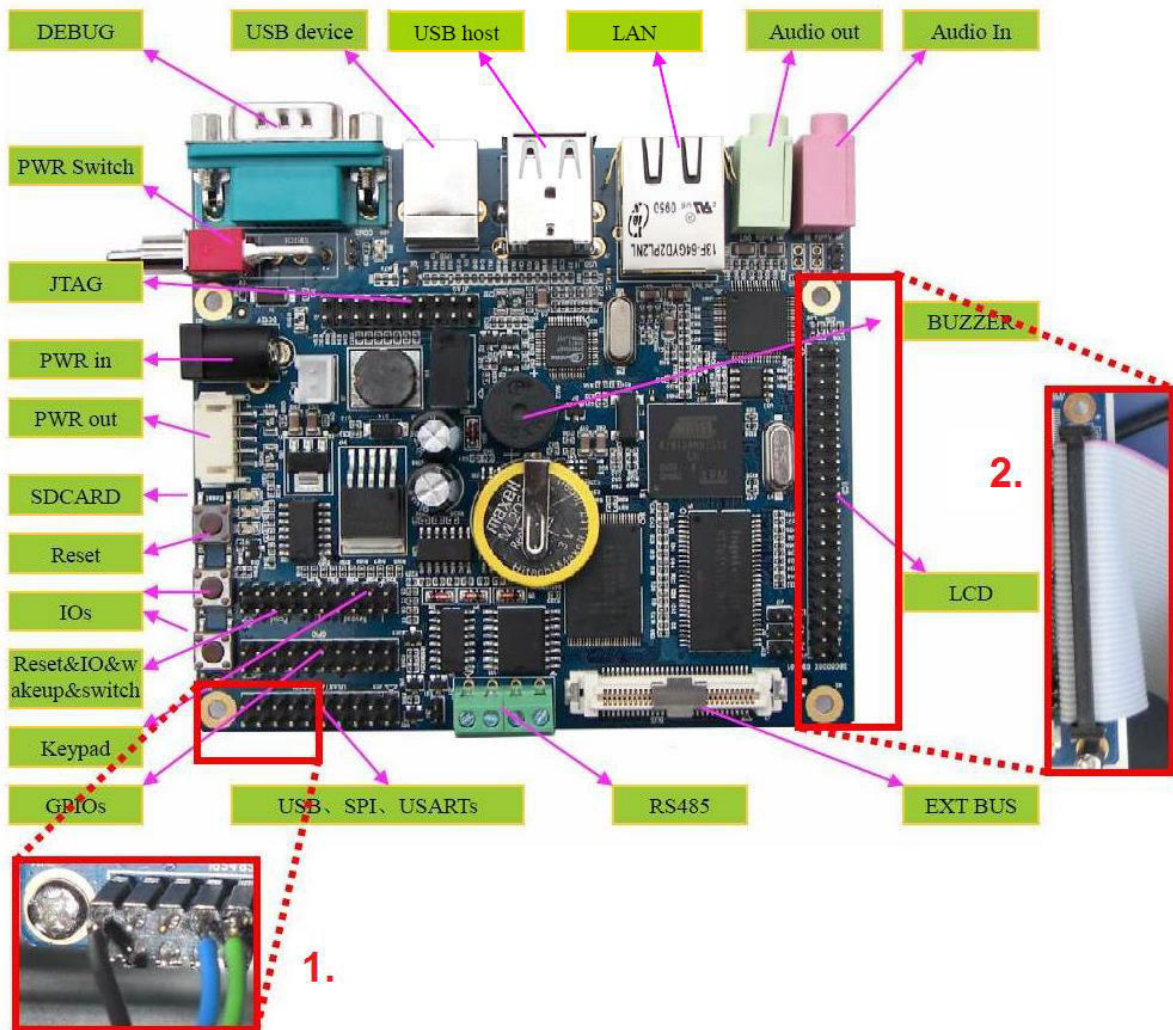

1. Attach connector communication control board as shown (black cable to the outside)
2. Attach LCD connector as shown (red stripe toward Audio in/out)

9.5 Software parameters

9.5.1 Configuration file (config.mcf)

Ini-key	Default value	Help
b_all_tools	F	TRUE -> Change all Packs is active
b_aquinity_start	F	TRUE -> Water production is running
b_lf_sensor_1	F	TRUE -> LF1 is in working range
b_lf_sensor_2	F	TRUE -> LF2 is in working range
b_load_save_backup	F	Not used anymore
b_tank_level_limit	F	TRUE -> Tank is full
b_temp_too_high	F	TRUE -> T3 is over limit
dbl_init_q1_value	50	Init value of Q1 Sensor
dbl_init_q2_value	5	Init value of Q2 Sensor
dbl_init_q3_value	0,055	Init value of Q3 Sensor
dbl_init_q4_value	0,055	Init value of Q4 Sensor
dbl_init_tank_level	25	Init value of Tank Sensor
dbl_init_toc_value	3	Init value of TOC (abs (Q3-Q4))
dbl_q_tank_volt_limit_warning	0,01	(0,01V) on all sensors -> COM failure!
dbl_q1_set_limit_min	1	Q1 < 1µS -> Error
dbl_q2_set_limit_min	0,035	Q2 < 0.035µS -> Error
dbl_q3_set_limit_min	0,035	Q3 < 0.035µS -> Error
dbl_sec_back_to_main	1200	After 2 mins back to main
dbl_sec_call_memory	60	Refresh memory display (1 min)
dbl_sec_check_op_hours	600	Update operating hours (10 mins)
dbl_sec_check_p1_counter	1800	Check P1 counter (30 min)
dbl_sec_count_op_hours	60	Counter for operating hours (1 min)
dbl_sec_data_high_density	3600	Acquire data every 1 hour
dbl_sec_data_low_density	86400	Acquire data every 24 hours
dbl_sec_data_mid_density	43200	Acquire data every 12 hours
dbl_sec_flush_change_cm	3600	Init flushing Con.M. (1 hr)(AQ²E only)
dbl_sec_flush_change_cm_edi	3600	Flushing Con.M. after change (1 hr)
dbl_sec_flush_change_pp	300	Init flushing PropPak (5 min)
dbl_sec_flush_cm_go_idle	0	Flush Con.M. when tank full (0 sec)
dbl_sec_flush_edi_go_idle	300	5 mins flush EDI when Tank full
dbl_sec_flush_ro_go_idle	60	Flush RO when tank full (1 min)
dbl_sec_flush_upw_uf	300	5 mins flush UF after change
dbl_sec_flush_upw_uf_sv6_close	15	Flushing PW -> SV6 close (15 sec)
dbl_sec_flush_upw_uf_sv6_open	60	Flushing PW -> SV6 open (15 sec)
dbl_sec_init_flush_upw_no_uf	300	5 mins first flush UPW-Pack
dbl_sec_init_flush_upw_uf	2700	45 mins first flush UF module
dbl_sec_init_uf_sv6_close	10	Init flushing PW -> SV6 close (10 sec)
dbl_sec_init_uf_sv6_open	10	Init flushing PW -> SV6 open (10 sec)
dbl_sec_io_command_hs	30	Handshake with control PCB (30 sec)
dbl_sec_message_switcher	2	Switch Messages every (2 sec)
dbl_sec_no_comm_warning	120	Time to show error NO COMM (2 mins)
dbl_sec_no_ps1_over	10	PS1 problem is over, 10s wait, back
dbl_sec_no_ps1_sv1_close	5	PS1 problem, close SV1 for 5s
dbl_sec_no_ps1_sv1_open	2	PS1 problem, open SV1 for 2s
dbl_sec_p2_12_active	300	Recirculating time (5 min) (when full)
dbl_sec_p2_12_sleep	10800	System sleep time (3 hr) (when full)
dbl_sec_ps1_error	1800	30 mins Pressure problem -> STOP
dbl_sec_ps1_warning	15	15 secs Pressure problem -> Warning

Service setup

dbl_sec_q1_out_error	1800	30 mins Q1 problem -> STOP
dbl_sec_q2_out_error	1800	Q2 is out of range (30 min) STOP
dbl_sec_q3_out_error	1800	Q3 < 0.045µS (30 mins) -> STOP
dbl_sec_q3_out_warning	180	Q3 > limit (3 mins) -> WARN
dbl_sec_release_pressure	8	Time to release pressure (8 sec)
dbl_sec_upw_desinf_sv6_close	10	SV6 close for (10 s) by disinfection
dbl_sec_upw_desinf_sv6_open	10	SV6 open for (10 s) by disinfection
dbl_sec_venting_upw	30	30 secs venting UPW
dbl_sec_venting_upw_sv6_close	5	Venting PW -> SV6 close (5 sec)
dbl_sec_venting_upw_sv6_open	5	Venting PW -> SV6 open (5 sec)
dbl_t3_limit_warning	40	T3 max. -> show Warning
dbl_t3_limit_warning_exit	38	T3 -> exit Warning
dbl_tank_level_desinf	70	minimal Tank (%) to start disinfection
dbl_tank_level_min_dry	10	10% Tank level dry-protection
dbl_tank_level_min_init	50	Min (50%) Tank level for first start
dbl_tank_level_min_tap	15	Min (15%) Tank level for water tap
dbl_tank_level_tool	50	minimal (%) Tank to start UPW/UF tool
str_backup_calib_file	\\Had Disk\calib.mcf	Path of calibration file backup
str_backup_config_file	\\Hard Disk\config.mcf	Path of config file backup
str_backup_file_high_density	\\Hard Disk\data_high.dat	Path of data high file backup
str_backup_file_low_density	\\Hard Disk\data_low.dat	Path of data low file backup
str_backup_file_mid_density	\\Hard Disk\data_mid.dat	Path of data mid file backup
str_backup_file_op_hour	\\Hard Disk\op_hour.dat	Path of operating hour file backup
str_backup_log_file	\\Hard Disk\log_file.dat	Path of logfile backup
str_first_start_device	init_device_1	Default state of initial process
str_path_file_high_density	\\NandFlash\data_high.dat	Path of data high file
str_path_file_low_density	\\NandFlash\data_low.dat	Path of data low file
str_path_file_mid_density	\\NandFlash\data_mid.dat	Path of data mid file
str_path_file_op_hour	\\NandFlash\op_hour.dat	Path of operating hour file
str_path_log_file	\\NandFlash\logfile.dat	Path of logfile
str_path_temp_file	\\NandFlash\temp.dat	Path of temp file
str_standard_device	aquinity	Default state of normal process
str_tool_first_start	tool_first_start	Default state of first tool process
u16_mins_init_flush_ro	15	15 mins init FlushRO (AQ ² P, AQ ² P10)
u16_mins_init_flush_ro_edi	60	Init. FlushRO EDI for 60 mins (AQ ² E)
u32_count_mins_desinfection	129600	Reminder of disinfection (3 Months)
u8_ai_bit_q1	0	0(12-bit), 1(14-bit), 2(16-bit), 3(18-bit)
u8_ai_bit_q2	0	0(12-bit), 1(14-bit), 2(16-bit), 3(18-bit)
u8_ai_bit_q3	0	0(12-bit), 1(14-bit), 2(16-bit), 3(18-bit)
u8_ai_bit_q4	0	0(12-bit), 1(14-bit), 2(16-bit), 3(18-bit)
u8_ai_bit_t2	0	0(12-bit), 1(14-bit), 2(16-bit), 3(18-bit)
u8_ai_bit_t3	0	0(12-bit), 1(14-bit), 2(16-bit), 3(18-bit)
u8_ai_bit_t4	0	0(12-bit), 1(14-bit), 2(16-bit), 3(18-bit)
u8_ai_bit_tank	0	0(12-bit), 1(14-bit), 2(16-bit), 3(18-bit)
u8_ai_port_q1	1	AI-port Q1
u8_ai_port_q2	3	AI-port Q2
u8_ai_port_q3	5	AI-port Q3
u8_ai_port_q4	7	AI-port Q4
u8_ai_port_t2	4	AI-port T2
u8_ai_port_t3	6	AI-port T3
u8_ai_port_t4	8	AI-port T4
u8_ai_port_tank	13	AI-port tank
u8_chart_sensor	0	Display sensors for Service
u8_chart_sensor_2	0	Display sensors for Customer

Service setup

u8_chart_time	0	option 7days/12months/24hr
u8_count_tank_swimmer	2	Max. count of swimmer count (Mo-Su)
u8_count_week_reboot	4	after 4x Sundays -> restart device
u8_device_type	3	0:AQ ² E 1:AQ ² P 2:AQ ² P10 3:As ²
u8_device_version	0	0:RE 1:AL 2:LS 3:AL,TI 4:LS,TI
u8_di_port_intake_nc	4	DI-port water tap (NC)
u8_di_port_ps1	1	DI-port Pressure sensor
u8_di_port_regen	2	DI-port Regen
u8_di_port_salt	7	DI-port salt
u8_di_port_softener	8	DI-port Softener
u8_di_port_swimmer	3	DI-port swimmer
u8_di_port_tank_high	5	DI port tank level high
u8_di_port_tank_low	6	DI port tank level low
u8_hour_system_awake	5	at 5 am system start process
u8_hour_system_sleep	20	at 8 pm system goes to sleep
u8_init_value_array_size	5	init value -> array of 5 elements
u8_login_prio	0	0: no login / 1: user / 2:service
u8_login_prio_temp	0	Temp login prio
u8_p1_counter_max	9	Max. count of P1 (check every 30 min)
u8_q_setting	1	1/2/3/4 == q1 q2/q3/q4
u8_system_weekday_first	2	on (Monday) system starts working
u8_system_weekday_last	6	on (Friday) system stops working
u8_tool_option	0	Selector for tool

9.5.2 Calibration file (calib.mcf)

Ini-key	Default value	Help
b_desinf_status	F	TRUE -> disinfection is running
b_normal_start	F	FALSE -> first start is active
b_option_interval	T	FALSE -> permanent recirculation
b_option_q3_unit	F	FALSE -> µS/cm
b_option_regen	F	Not used
b_option_toc	F	TRUE -> TOC monitor is active
b_option_uf_mod	F	TRUE -> UF Modul is active
b_option_uS_control	F	TRUE -> option µS is active
b_option_uvpw	F	TRUE -> UV Lamp is active
b_option_uvt	F	TRUE -> UV in tank is active
dbl_q1_c_cond_max	230	For Calibration!
dbl_q1_c_cond_min	0	For Calibration!
dbl_q1_set_limit_max	20	max. allowed Q1
dbl_q2_c_cond_max	23	For Calibration!
dbl_q2_c_cond_min	0	For Calibration!
dbl_q2_set_limit_max	0,1	max. allowed Q2
dbl_q2_t_temp_max	90	For Calibration!
dbl_q2_t_temp_min	0	For Calibration!
dbl_q3_c_cond_max	2,3	For Calibration!
dbl_q3_c_cond_min	0	For Calibration!
dbl_q3_set_limit_max	0,07	max. allowed Q3
dbl_q3_t_temp_max	90	For Calibration!
dbl_q3_t_temp_min	0	For Calibration!
dbl_q4_c_cond_max	2,3	For Calibration!
dbl_q4_c_cond_min	0	For Calibration!

dbl_q4_t_temp_max	90	For Calibration!
dbl_q4_t_temp_min	0	For Calibration!
dbl_tank_limit_high	100	Tank level limit to stop production
dbl_tank_limit_low	70	Tank level limit to start production
dbl_tank_vol_max	100	For Calibration!
dbl_tank_vol_min	0	For Calibration!
dbl_tank_vol_value	-	
dbl_tank_volt_max	3,6	For Calibration!
dbl_tank_volt_min	0	For Calibration!
dbl_tank_volt_value	-	Read sensor
dbl_toc_factor	0,1	multiplier of (Q3-Q4)
dbl_toc_offset	0	offset of (Q3-Q4)
str_serial_number	RW_ _ _ _ _	after Endtest, get a serial number
u16_hour_ro_flush_idle_int	12	12hr flush interval when idle
u16_mins_ro_flush	5	Flushing RO (5 mins) when starting
u16_mins_ro_flush_idle	20	Flushing RO (20mins) wenn idle
u16_mins_upw_flush_desinf	50	Disinfection: 50 mins flushing UPW
u16_mins_upw_recirc	10	Disinfection: 10 mins recirculation UPW
u32_uvr_counter	0	how many times UVPW is switched ON
u8_desinf_reminder	2 (6 Months)	Reminder [selector]

9.5.3 Operating hours file (op_hour.dat)

Ini-key	Default value	Help
limit_time_cm	850	850 hours
limit_time_p1	8000	8000 hours
limit_time_p2	8000	8000 hours
limit_time_pro_pack	850	850 hours
limit_time_uf_pw	8000	8000 hours
limit_time_upw	8000	8000 hours
limit_time_uvr	8000	8000 hours
limit_time_uvt	8000	8000 hours

10 Services FAQ's

Q: How to change the maximum limit of conductivity sensors?

A: Max. limit of conductivity Q1 & Q2 can be adjusted in the menu (only for service; see chapter 9.1.2)

Q: How to change the maximum limit of temperature T3?

A: Search for parameter *dbl_t3_limit_warning* in *config.mcf* with using *.mcf*-editor (only for service; see chapter 9.1.11), change the value, then click "Save Config"

Q: How to calibrate the touchscreen?

A: See chapter 9.1.12 for complete guide

Hauptplatine / Mainboard

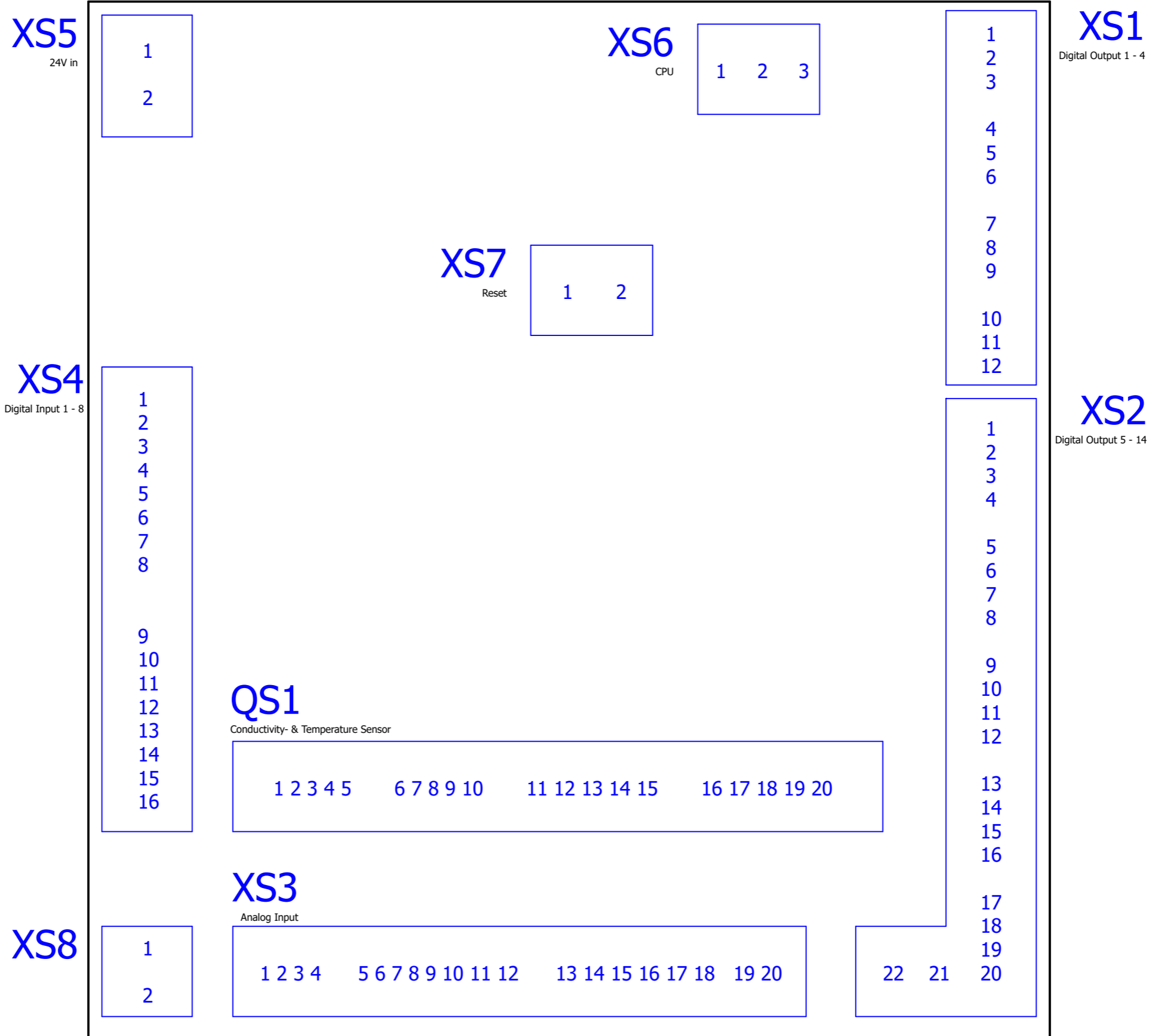

		Datum	17.04.2018			Membrapure GmbH	Hauptplatine			=
		Bearb.	Beginner							+
		Gepr		EPLAN Aquinity ² E-P Rev.2				EPL-Aq ² E-PR2-001		Blatt 1
Änderung	Datum	Name	Urspr	Ersatz von	Ersetzt durch					Blatt 18

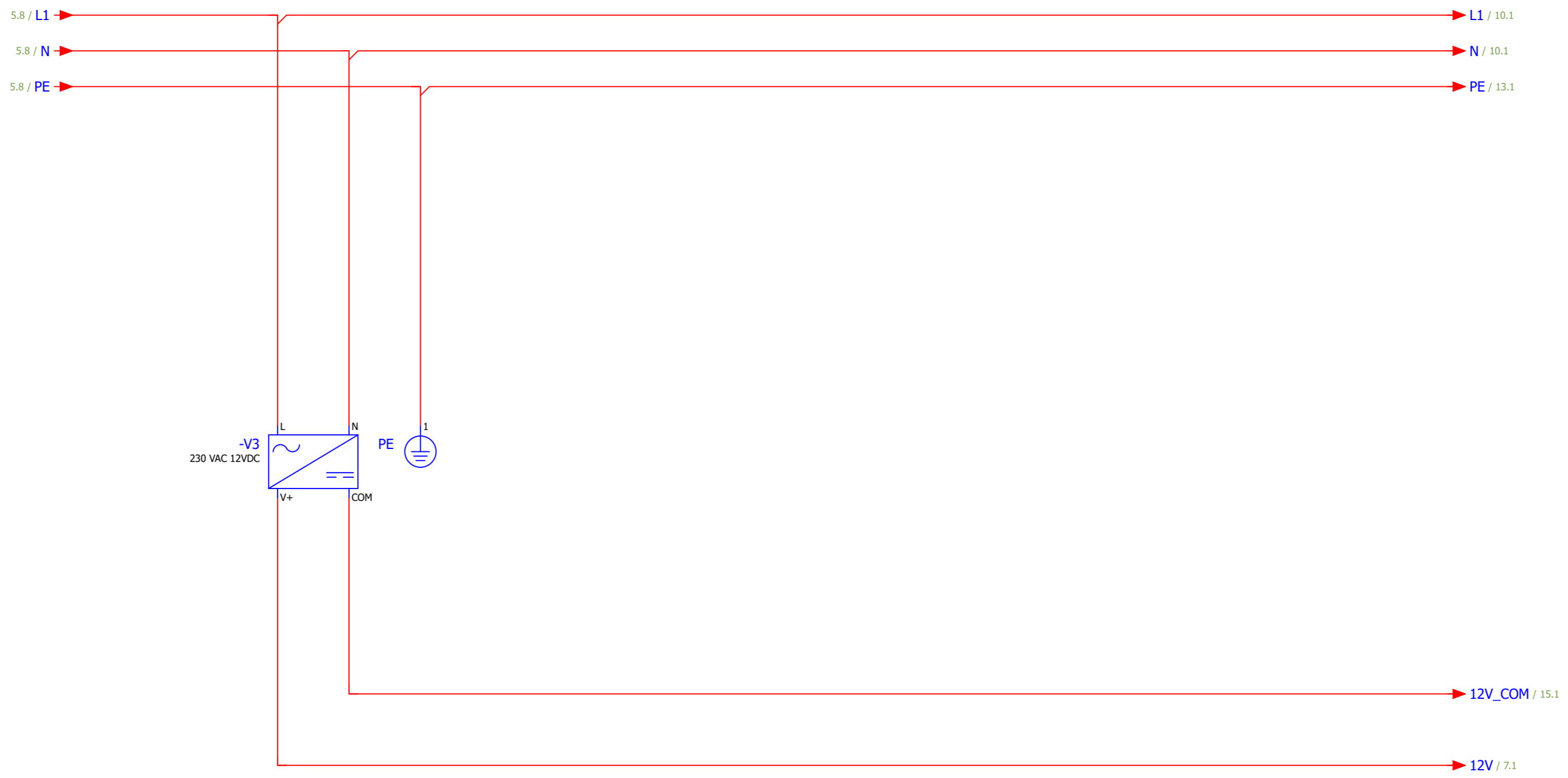

			Datum	18.04.2018	EPLAN Aquinity ² E-P Rev.2	Memrapure GmbH	Netzteil / Power supply 12V	EPL-Aq ² E-PR2-001	=	Blatt 6
			Bearb.	Beginner					+	
			Gepr							
Änderung	Datum	Name	Urspr		Ersatz von	Ersetzt durch				Blatt 18

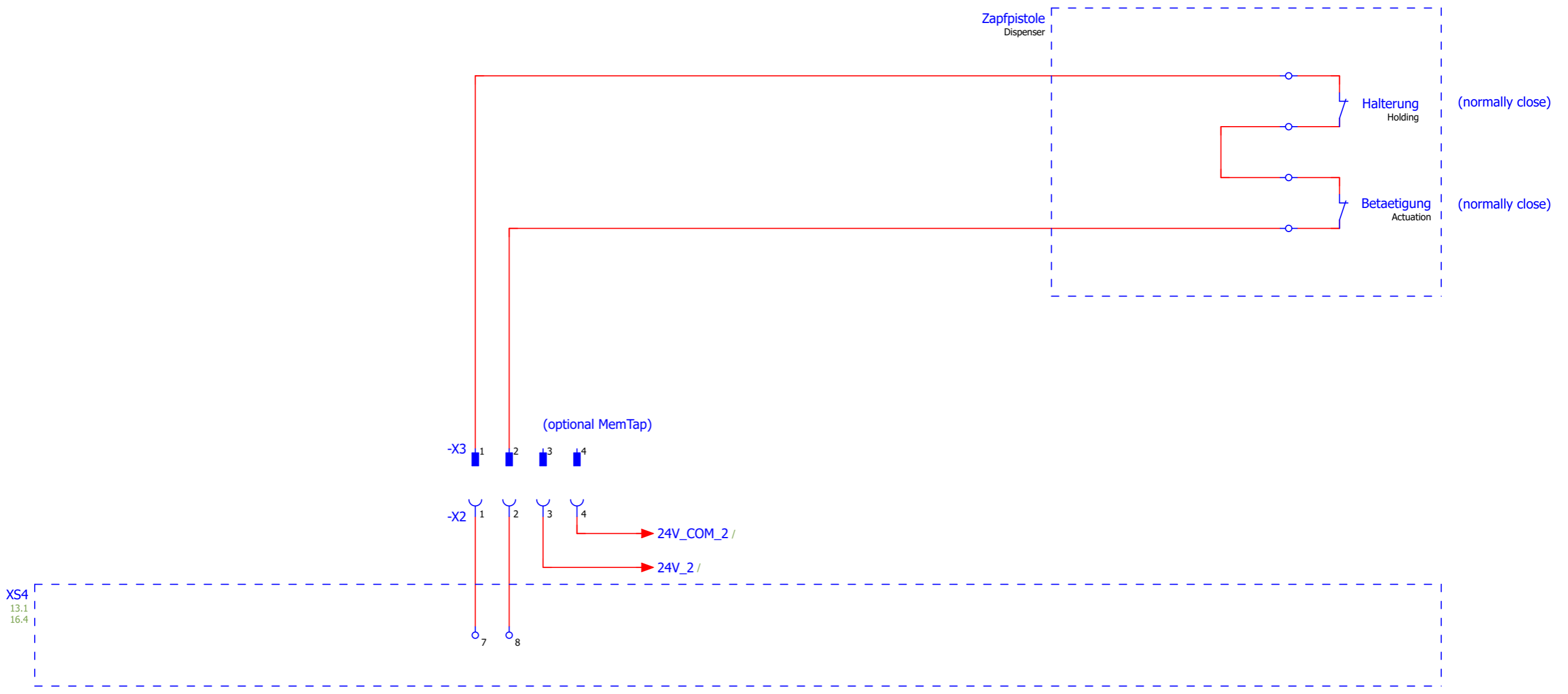

			Datum	25.04.2018	EPLAN Aquinity ² E-P Rev.2	Membrapure GmbH	Dispenser	EPL-Aq ² E-PR2-001	=	
			Bearb.	Beginner					+	
			Gepr						Blatt	12
Änderung	Datum	Name	Urspr		Ersatz von	Ersetzt durch			Blatt	18

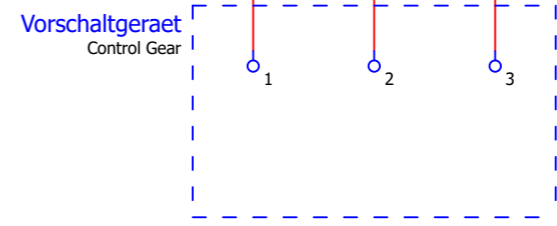
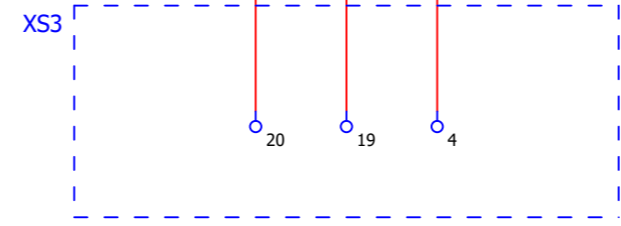
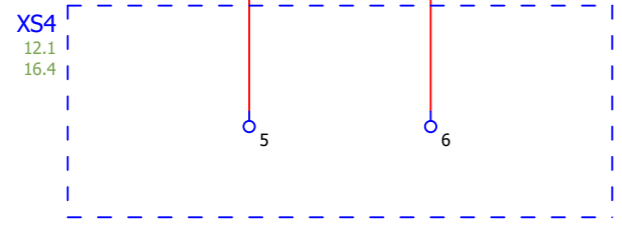
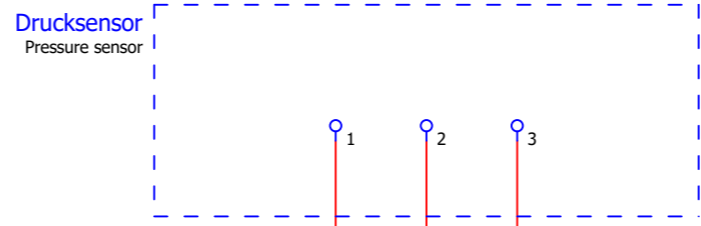
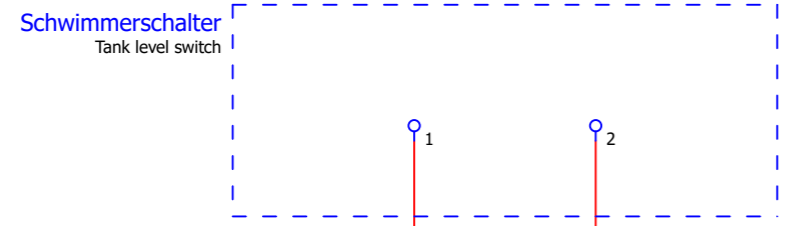
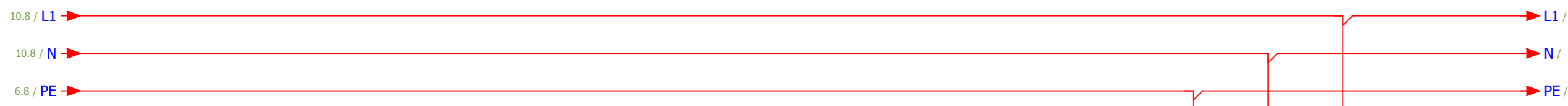

UV-Tank

		Datum	20.04.2018		EPLAN Aquinity ² E-P Rev.2	Memrapure GmbH	Tank			=		
		Bearb.	Beginner							+		
		Gepr										
Änderung	Datum	Name	Urspr		Ersatz von	Ersetzt durch			EPL-Aq ² E-PR2-001	Blatt 13		
										Blatt 18		

Optional (BI)

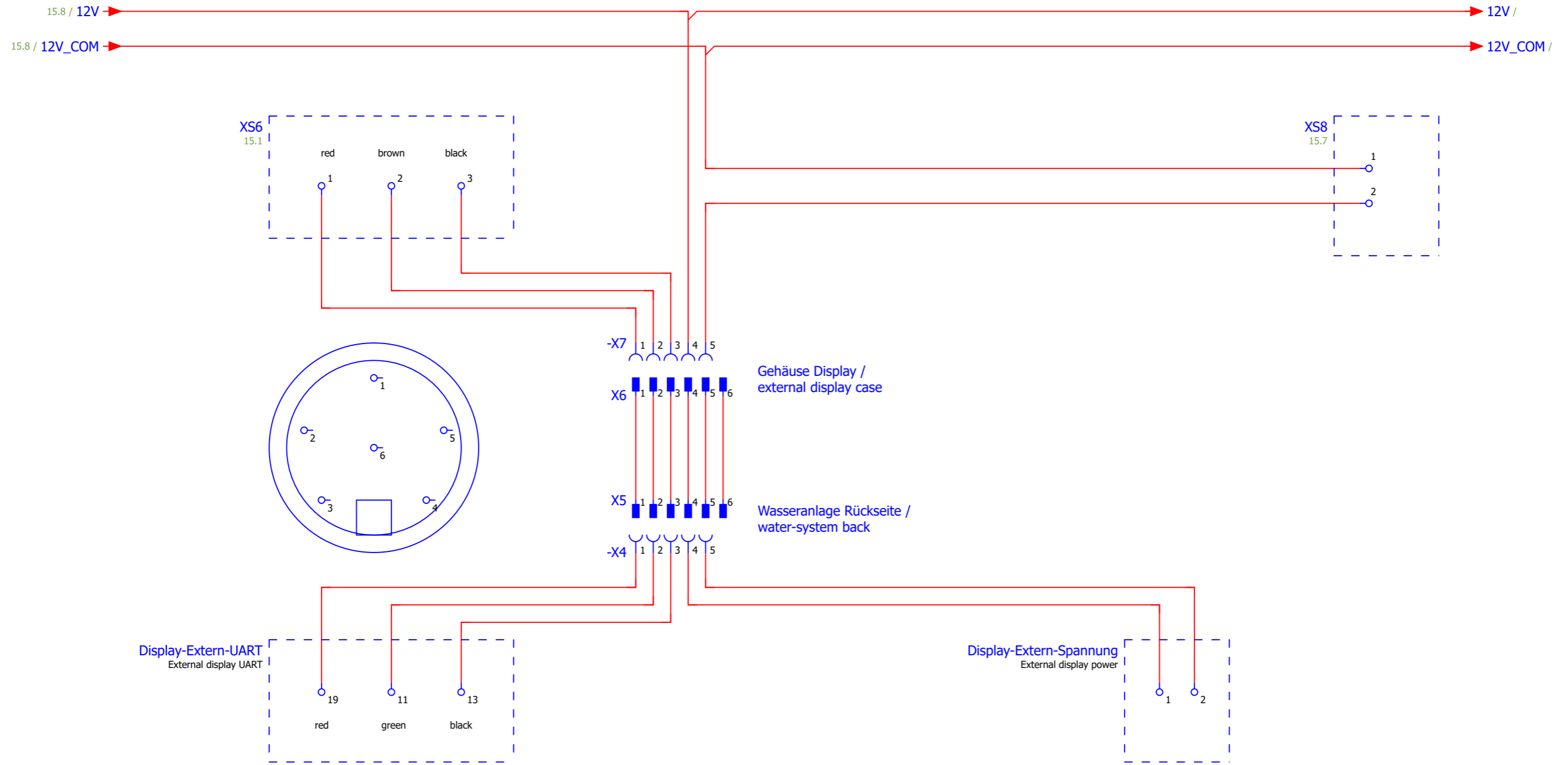

			Datum	18.04.2018	EPLAN Aquinity ² E-P Rev.2	Membrapure GmbH	Display extern (optional)	EPL-Aq ² E-PR2-001	=	
			Bearb.	Beginner					+	
			Gepr						Blatt	17
Änderung	Datum	Name	Urspr		Ersatz von	Ersetzt durch			Blatt	18

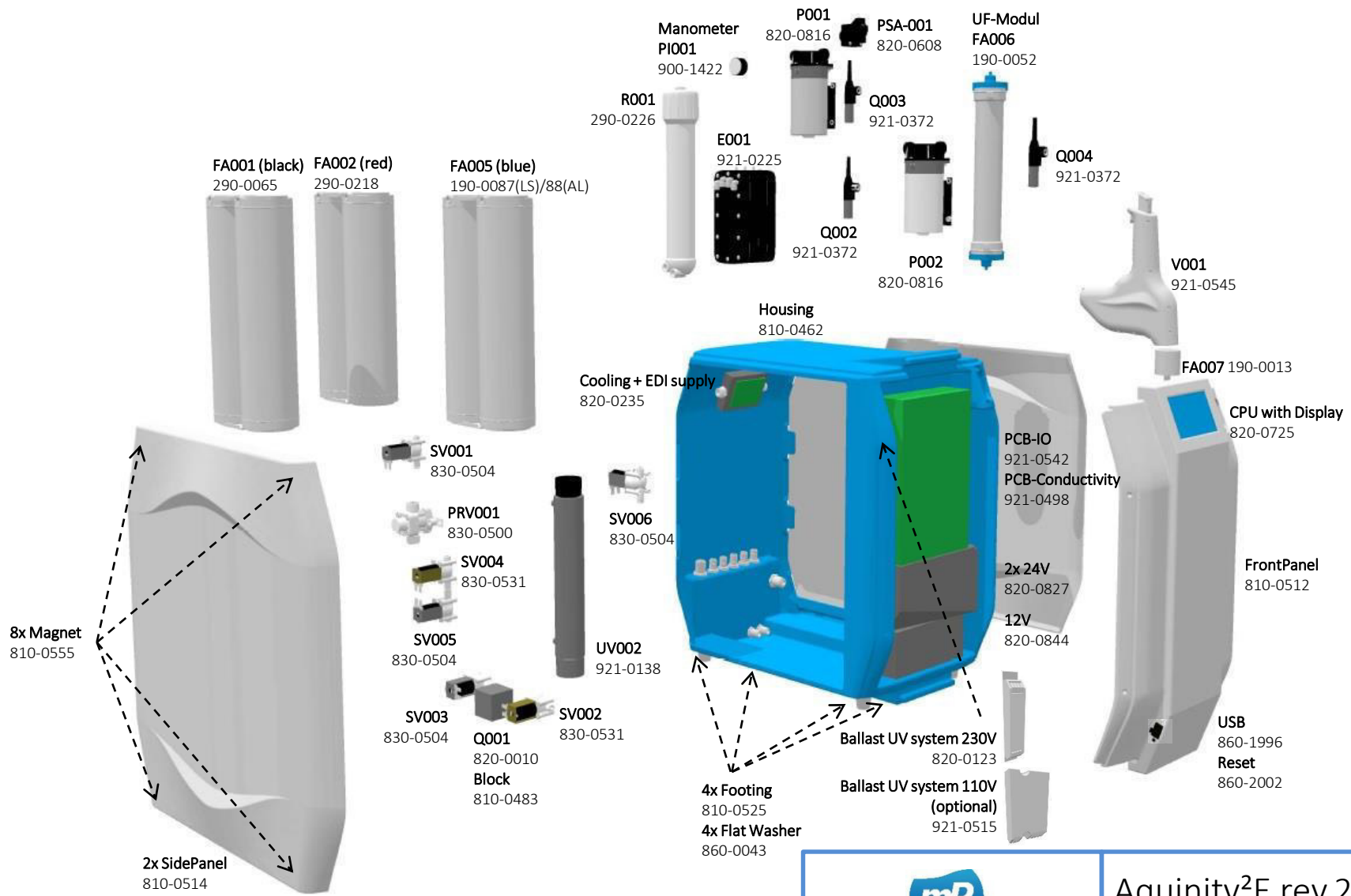

		Aquinity ² E rev.2	
		Exploded view v.1.0.	
Full System		HaS	2018.04.11

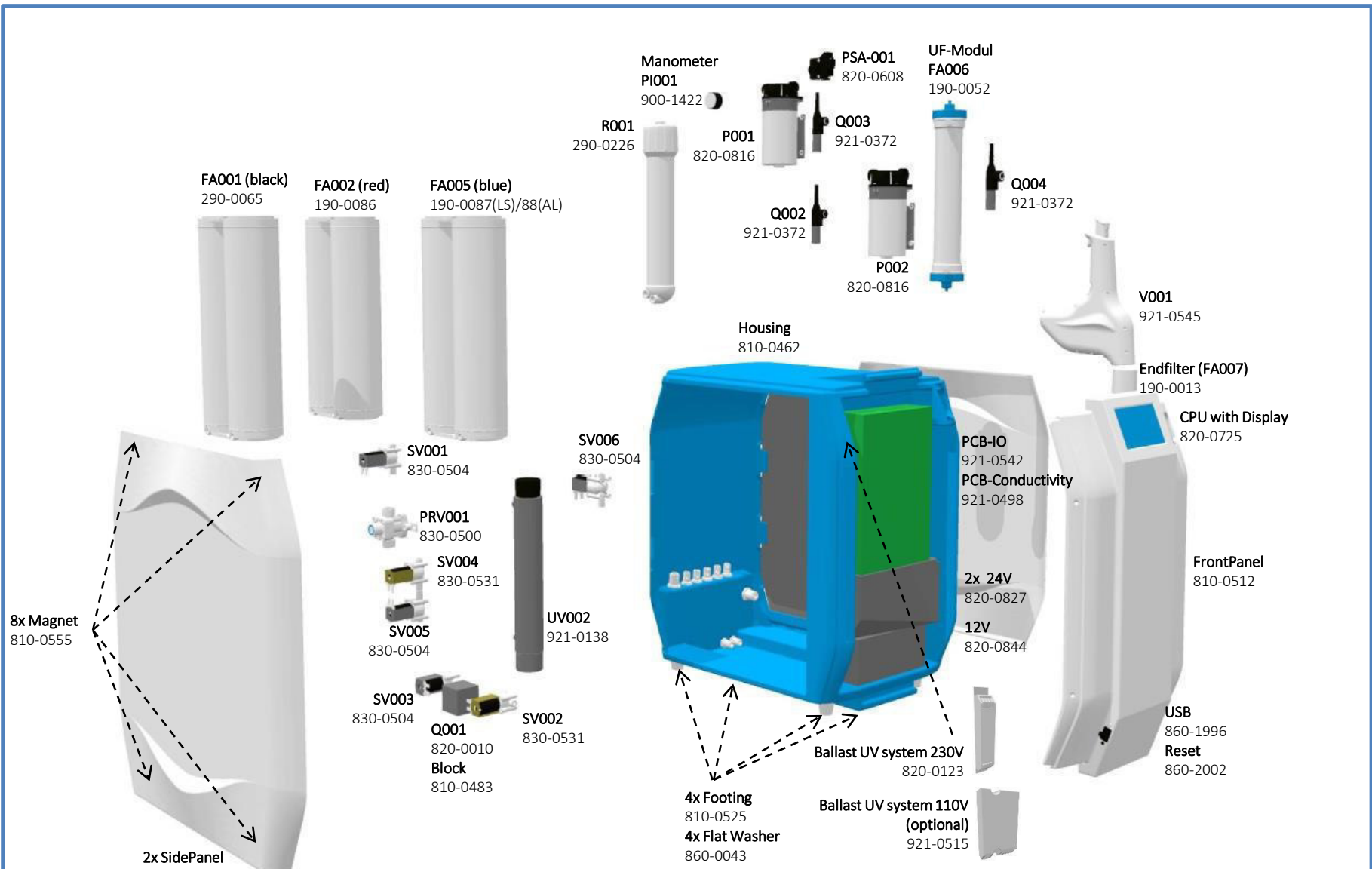

 WATER TOC AMINO	Aquinity ² P rev.2	
	Exploded view v.1.0.	
Full System	HaS	2018.04.11

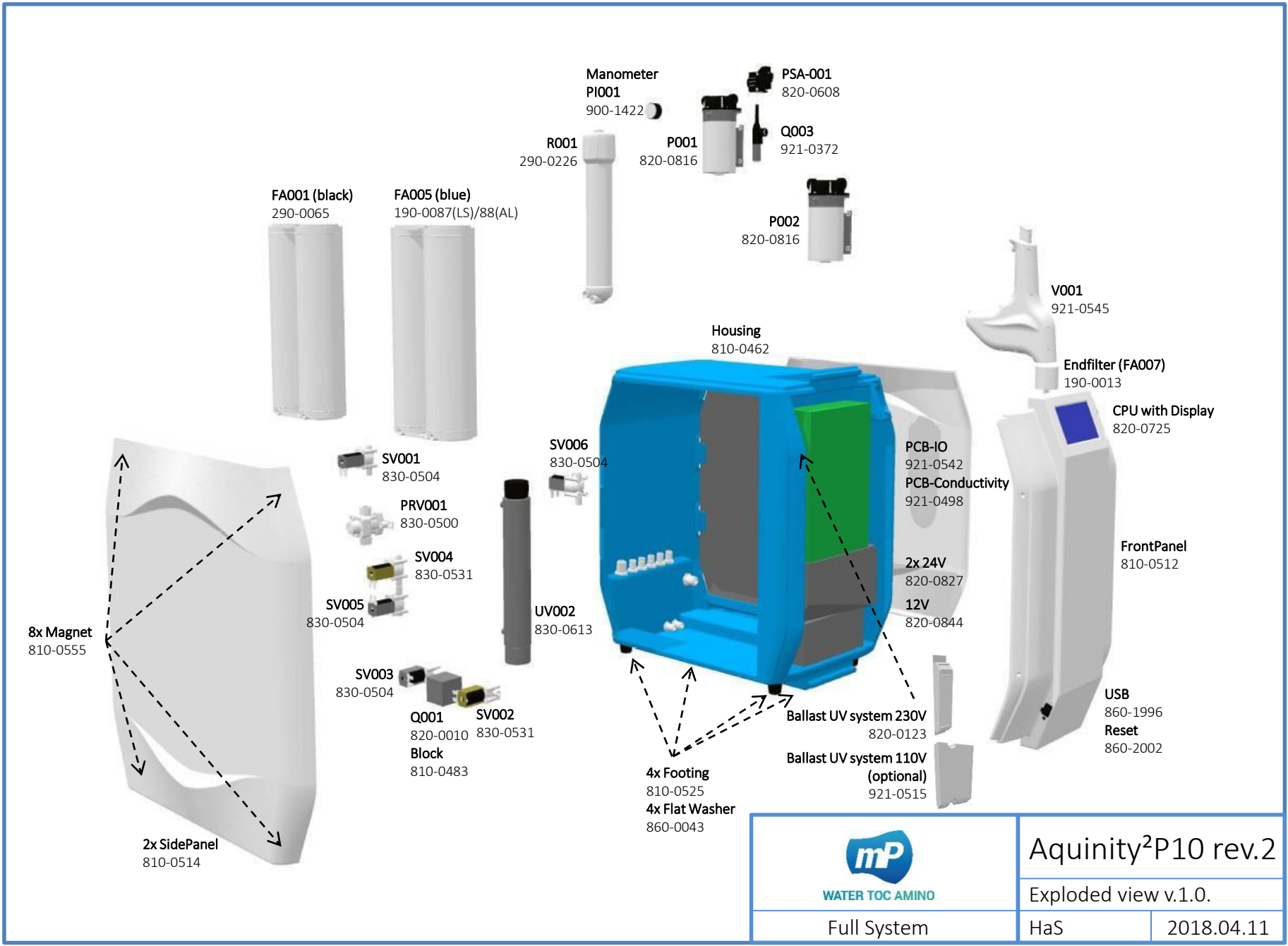

WATER TOC AMINO

Full System

Aquinity²P10 rev.2	
Exploded view v.1.0.	
HaS	2018.04.11

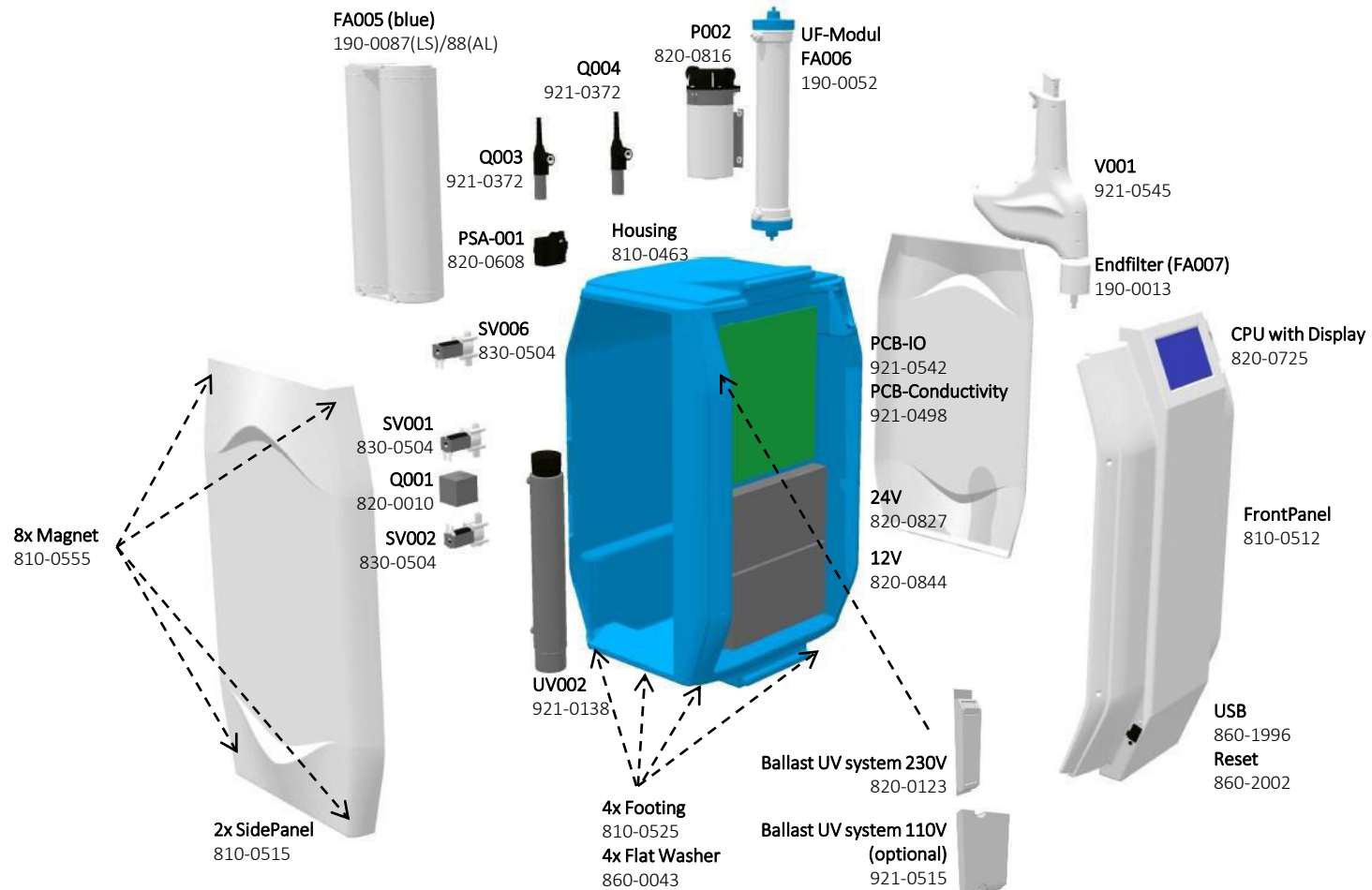

WATER TOC AMINO

Astacus² rev.2

Exploded view v.1.0.

Full System

HaS

2018.04.11

a

b

c

d

e

f

g

h

BACKSIDE - VIEW

FRONTSIDE - VIEW

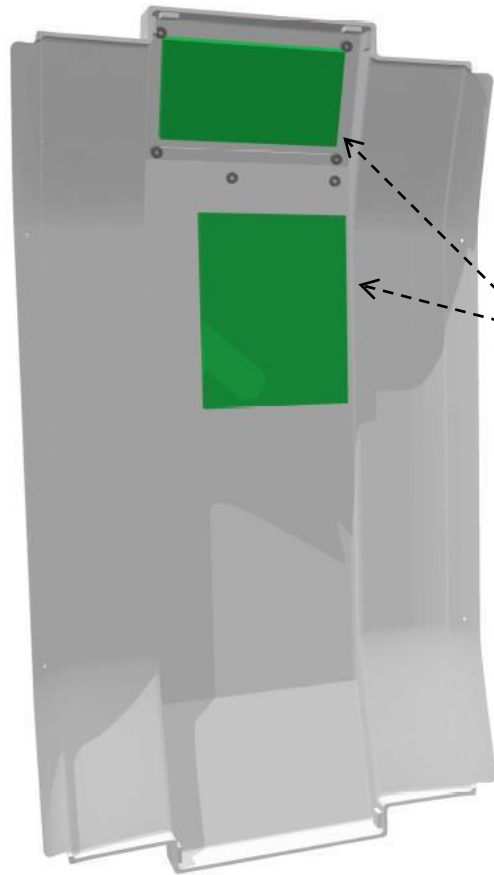

CPU with Display
820-0725



Reset
860-2002

USB
860-1996



WATER TOC AMINO

Aquinity²E / Aquinity²P /
Aquinity²P10 / Astacus²

Exploded view v.1.0.

Front panel (810-0512)

HaS

2018.04.11

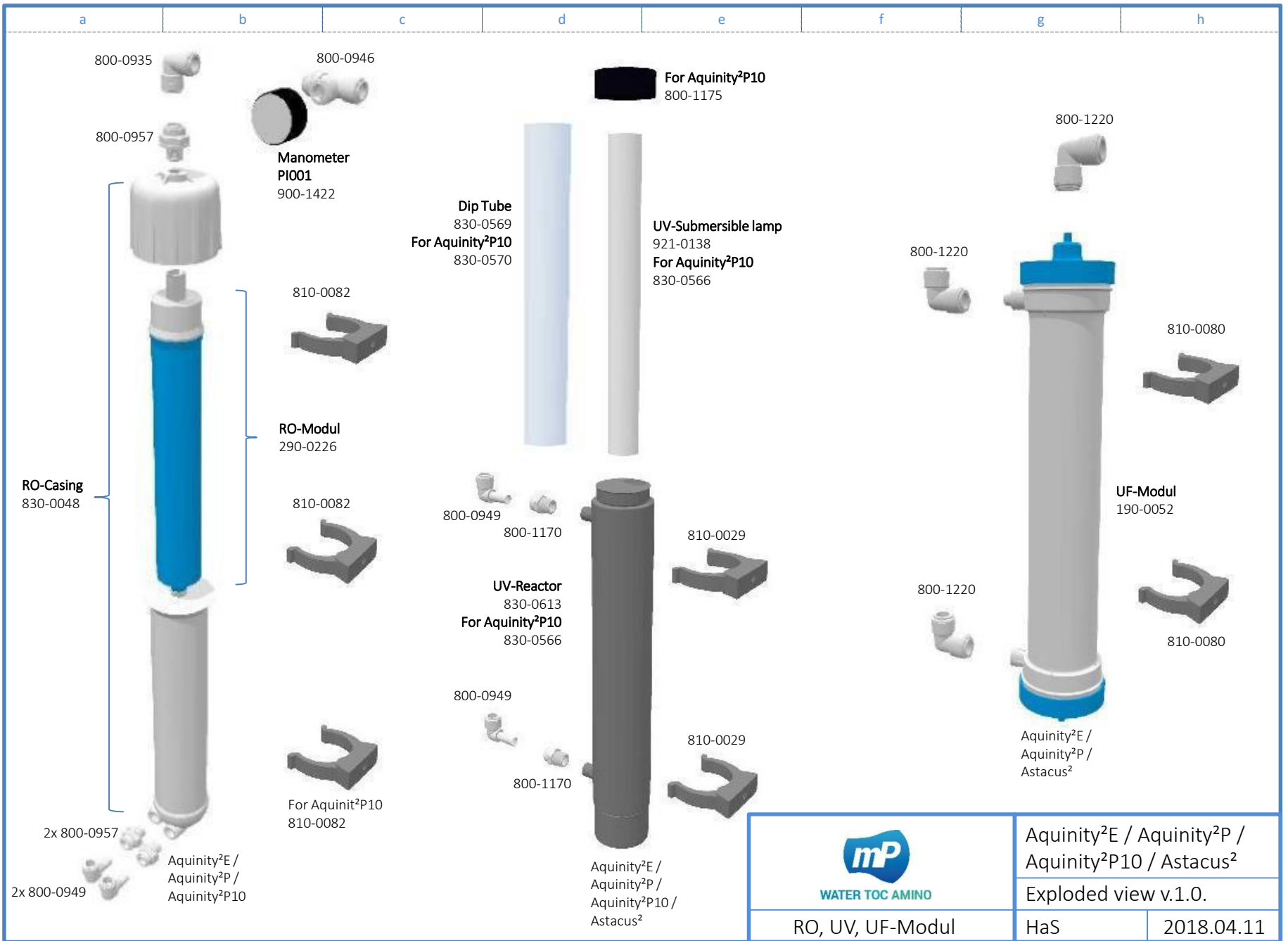

a b c d e f g h

800-0935

800-0946

For Aquinity²P10
800-1175

800-0957

**Manometer
PI001**
900-1422

Dip Tube
830-0569
For Aquinity²P10
830-0570

UV-Submersible lamp
921-0138
For Aquinity²P10
830-0566

800-1220

RO-Casing
830-0048

RO-Modul
290-0226

UF-Modul
190-0052

810-0082

810-0082

800-0949 800-1170

810-0029

UV-Reactor
830-0613
For Aquinity²P10
830-0566

800-1220

800-1220

810-0080

810-0080

Aquinity²E /
Aquinity²P /
Astacus²

2x 800-0957

For Aquinity²P10
810-0082

800-0949

810-0029

800-1170

Aquinity²E /
Aquinity²P /
Aquinity²P10 /
Astacus²



WATER TOC AMINO

Aquinity²E / Aquinity²P /
Aquinity²P10 / Astacus²

Exploded view v.1.0.

RO, UV, UF-Modul

HaS

2018.04.11

a b c d e f g h

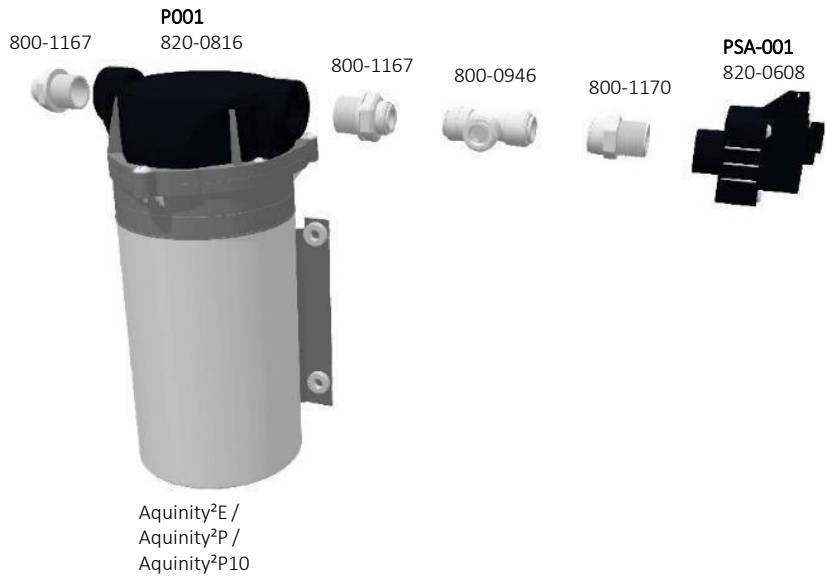

 mp WATER TOC AMINO	Aquinity ² E / Aquinity ² P / Aquinity ² P10 / Astacus ²	
	Exploded view v.1.0.	
Pump 1 & Pump 2	HaS	2018.04.11

a b c d e f g h

SV001
830-0504



Aquinity²E /
Aquinity²P /
Aquinity²P10 /
Astacus²

800-0949



SV003
830-0504



Aquinity²E /
Aquinity²P /
Aquinity²P10

800-1170

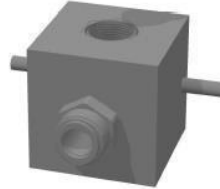

Q001
820-0010

Aquinity²E /
Aquinity²P /
Aquinity²P10 /
Astacus²

SV002 for Aquinity²E/P/P10
830-0531
SV002 for Astacus²
830-0504



800-0949



Aquinity²E /
Aquinity²P /
Aquinity²P10 /
Astacus²

SV004
830-0531

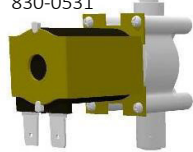

800-0946



800-0949



800-0949

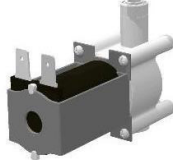

SV005
830-0504

Aquinity²E /
Aquinity²P

Q002
921-0372



800-0949



Aquinity²E /
Aquinity²P

Q003
921-0372



800-0949



Aquinity²E /
Aquinity²P /
Aquinity²P10 /
Astacus²

Q004 (optional)
921-0372



800-0949



Aquinity²E /
Aquinity²P /
Astacus²



WATER TOC AMINO

SV, LF-Sensors & Fittings

Aquinity²E / Aquinity²P /
Aquinity²P10 / Astacus²

Exploded view v.1.0.

HaS

2018.04.11

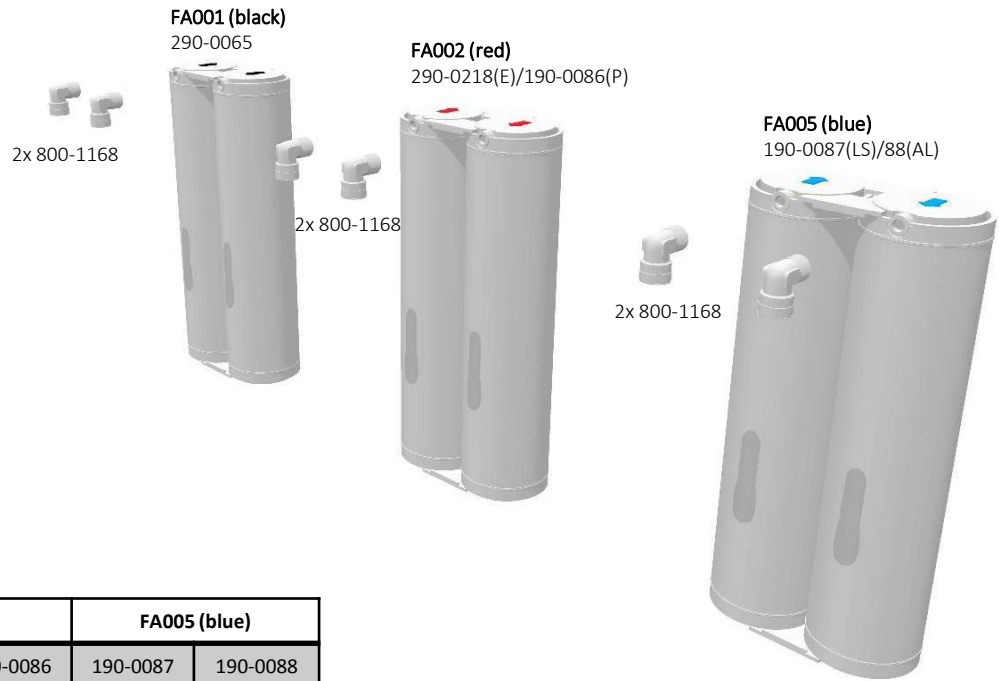

System	FA001 (black)	FA002 (red)		FA005 (blue)	
	290-0065	290-0218	190-0086	190-0087	190-0088
Aquinity² E 35/70L (Reagent)	x	x			x
Aquinity² E 35/70 L (Analytical; TI)	x	x			x
Aquinity² E 35/70 L (Life-Science; TI)	x	x		x	
Aquinity² P 35/70 L (Reagent)	x		x		x
Aquinity² P 35/70 L (Analytical; TI)	x		x		x
Aquinity² P 35/70 L (Life-Science; TI)	x		x	x	
Aquinity² P10 (Reagent)	x				x
Aquinity² P10 (Analytical)	x				x
Astacus² (Reagent)					x
Astacus² (Analytical; TI)					x
Astacus² (Life-Science; TI)				x	

 WATER TOC AMINO	Aquinity²E / Aquinity²P / Aquinity²P10 / Astacus²	
	Exploded view v.1.0.	
Consumable packs	HaS	2018.04.11

a

b

c

d

e

f

g

h

FRONTSIDE - VIEW



Wall-mounting
830-0578



Housing
830-0577

CPU with Display
820-0725

BOTTOMSIDE - VIEW



USB
860-1996

Plug socket 6 pole
860-1923

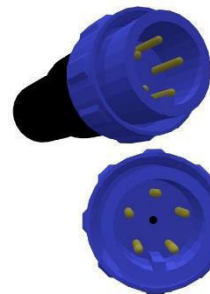

Plug 6 pole (5 pins)
860-1922



WATER TOC AMINO

Aquinity²E / Aquinity²P /
Aquinity²P10 / Astacus²

Exploded view v.1.0.

BI-Panel (180-0084)

HaS

2018.04.11

BACKSIDE - VIEW

FRONTSIDE - VIEW

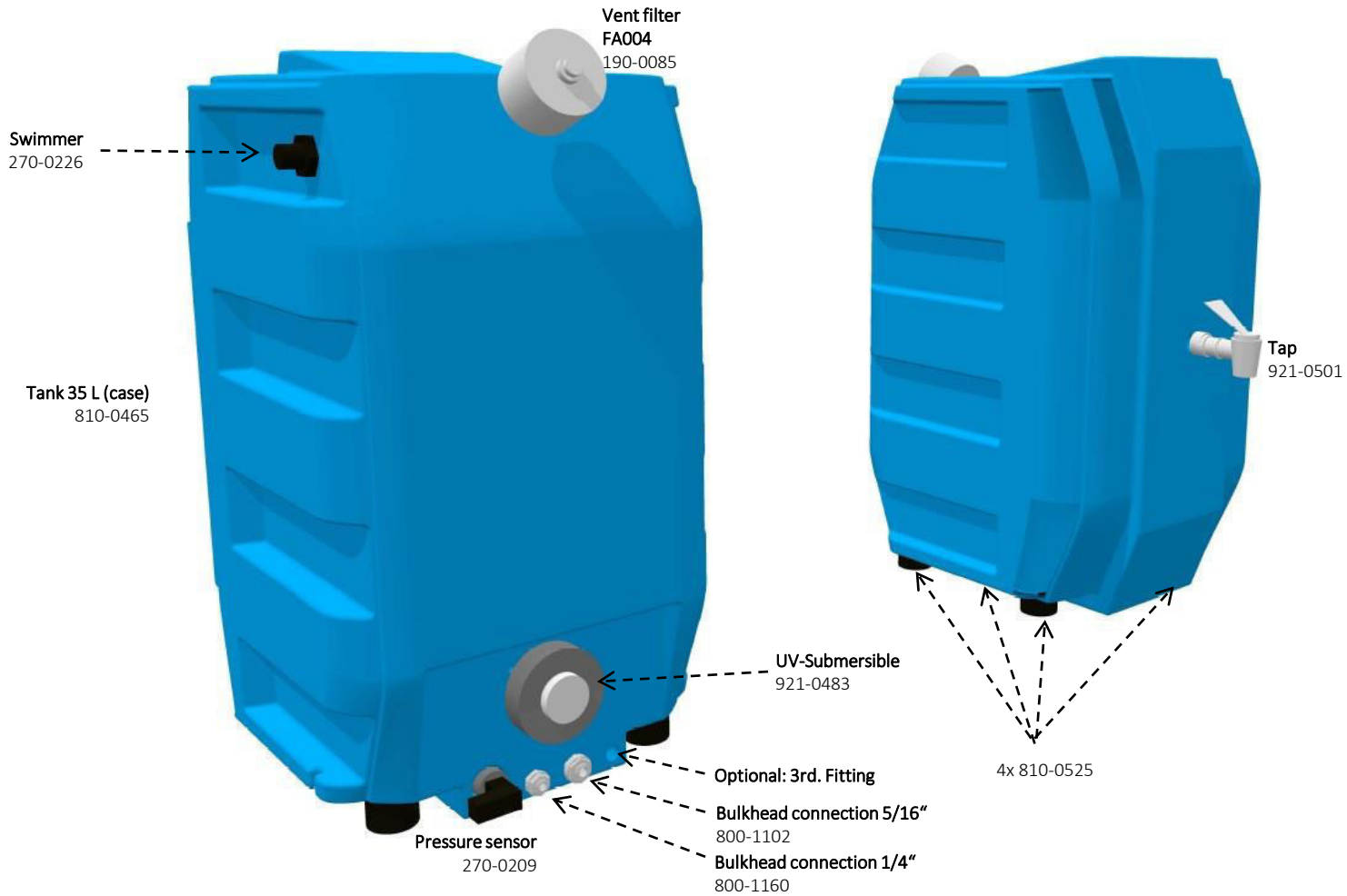

	Aquinity ² E / Aquinity ² P	
	Exploded view v.1.0.	
Tank 35L (830-0581)	HaS	2018.04.11

BACKSIDE - VIEW

Vent filter
FA004
190-0085

FRONTSIDE - VIEW

Swimmer
270-0226

Tank 70 L (case)
810-0464

Tap
921-0501

UV-Submersible
921-0483

4x 810-0525

Optional: 3rd. Fitting

Bulkhead connection 5/16"
800-1102

Bulkhead connection 1/4"
800-1160

Pressure sensor
270-0209

	Aquinity ² E / Aquinity ² P	
	Exploded view v.1.0.	
Tank 70L (830-0603)	HaS	2018.04.11

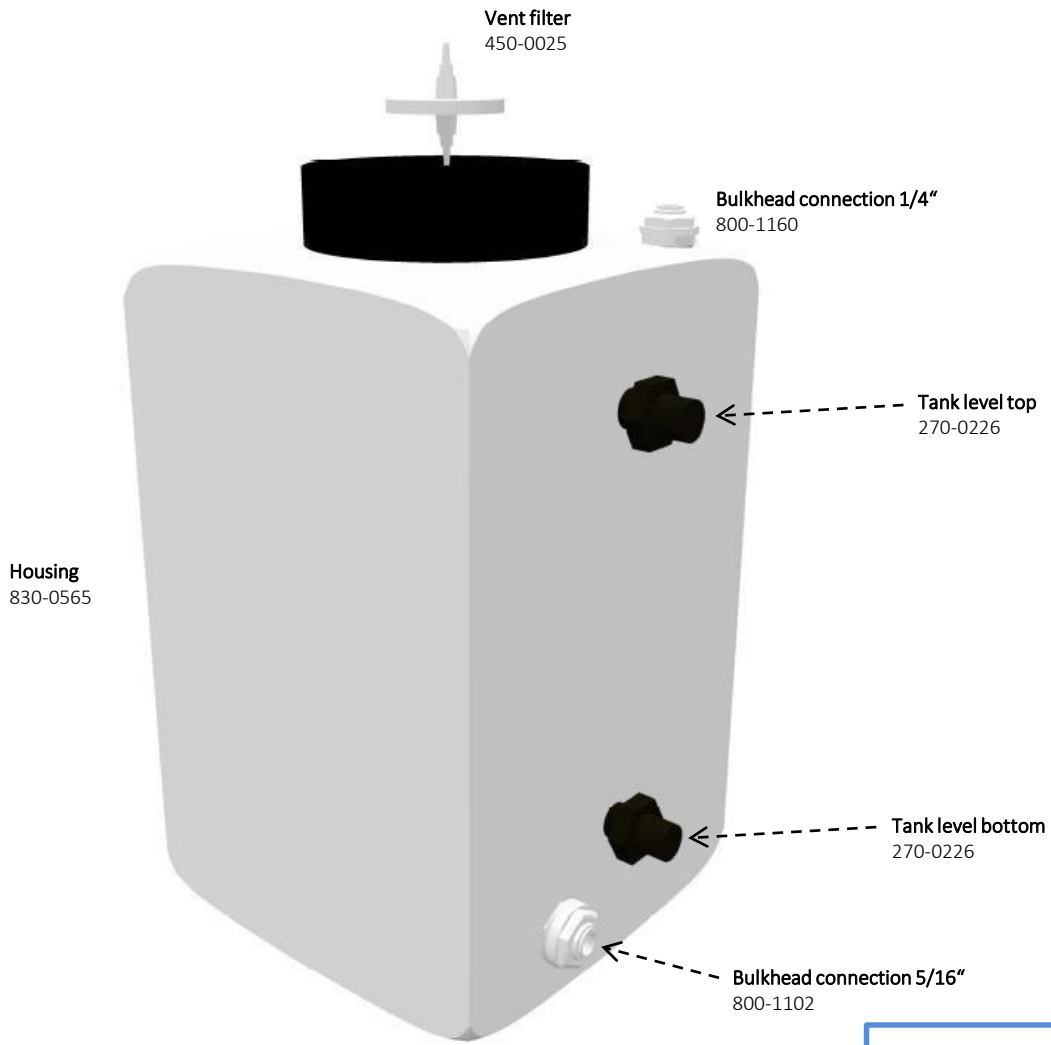

	Aquinity ² P10 rev.2	
	Exploded view v.1.0.	
Tank 10L (830-0640)	HaS	2018.04.11

a

b

c

d

e

f

g

h

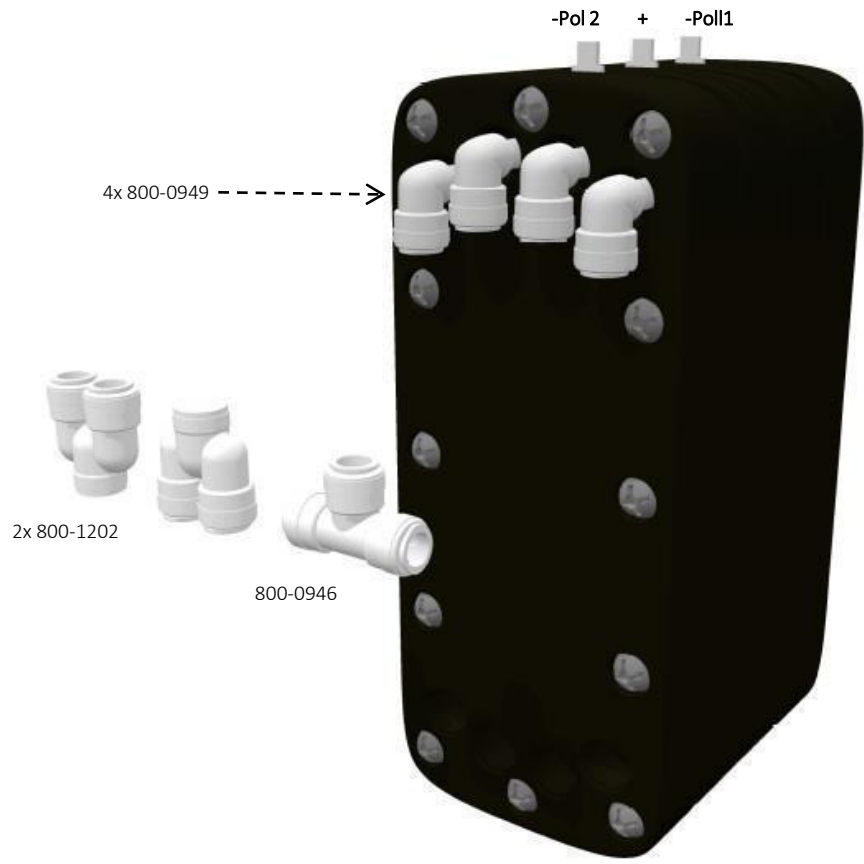

WATER TOC AMINO

Aquinity²E rev.2

Exploded view v.1.0.

EDI-Cell (921-0225)

HaS

2018.04.11

a

b

c

d

e

f

g

h

Female adapter NPTF thread
800-1174



Pressure regulator
180-0069

Pressure regulator 0-4 bar,
1/8" NPTF, PP
830-0564

Mounting bracket
810-0479

Ball valve 1/4" NPT, PP
180-0004



Manometer
900-0107



WATER TOC AMINO

Astacus² rev.2

Exploded view v.1.0.

Installationkit (180-0072)

HaS

2018.04.11

Artikel-Nr.	Name (Deutsch)	Name (English)	Info
180-0004	Kugelhahn PP 1/4"NPT	Ball valve 1/4" NPT, PP	
180-0069	Druckminderer, komplett 0 - 4 bar, 1/4" JG, PP	Pressure regulator 0 - 4 bar, 1/4" NPTF, PP, complete	
180-0074	MemTap S ²	MemTap S ²	
190-0013	Endfilter für Reinstwassersysteme, 0,2 µm, 2 l/min	Final filter, capsule, 0,2µm	FA007
190-0052	Ultrafiltrationsmodul MemCon 4	Ultrafiltration module type MemCon 4	FA006
190-0085	Belüftungsfiter Aquinity ²	Tank vent Aquinity ² ; integrated CO2-trap	FA004
190-0086	Konditionierungsmodul P für Aquinity ² P	Conditioning Module for Aquinity ² P	FA002
190-0087	MemPak LS Reinststufe für Aquinity ² /Astacus ²	MemPak LS Aquinity ² /Astacus ²	FA005
190-0088	MemPak AL Reinststufe Aquinity ² /Astacus ²	MemPak AL for Aquinity ² and Astacus ²	FA005
270-0209	Drucksensor 0-100 mbar, 0-10V	Pressure sensor for intelligent level control	LT001
270-0226	Schwimmerschalter Aquinity ²	Level control for Aquinity ² ; material PP,	LSH001, LSL001
280-0433	Wasserwächter für VE-Wasser 3/4"	Water leak sensor with 2m wire, O-Ring, Fitting	
290-0065	ProPak R10	Pretreatment modul - ProPak R10	FA001
290-0218	Konditionierungsmodul E für Aquinity ² E	Conditioning module for Aquinity ² E	FA002
290-0226	RO-Modul für RO/EDI-Systeme bis 20 l/h	Reverse osmosis membrane element 20 l/h	R001
290-0227	Chlortabletten	Chlorine tablets to sanitize	
450-0025	MEMBEX 50 PT, 0,20 µm, unsteril	MEMBEX 50 PT, nonsterile filter for venting	
800-0573	Rohrklemme JG d15	Pipe clamp JG d15	
800-0935	Winkelverbinder 1/4"	Elbow-Unit DM 1/4"	
800-0946	T-Verbinder DM 1/4"	T-Unit 1/4"	
800-0949	Einsteck-Winkel-Verbinder DM 1/4"x1/4" Stutzen	Tube Elbow Union DM 1/4" tube x 1/4" stem	
800-0957	Einschraubanschluss DM 1/4" auf 1/8" NPT Außengew.	Straight adaptor DM 1/4" to 1/8" NPTF	
800-0965	Sicherungsring DM 1/4"	Locking Clip - Connection: 1/4"	
800-0966	Schlauch PE DM 1/4"	Tube unfilled; 1/4" diameter PE	
800-1102	Schottanschluss 5/16" auf 5/16"	Bulkhead Union 5/16" to 5/16"	
800-1156	Einschraubanschluss DM 1/4" auf 1/8" Innengewinde	Straight adaptor DM 1/4" to 1/8" NPTF	
800-1158	Gerader Reduzierverbinder DM 5/16"/1/4" , PP	Reducing straight connector DM 5/16" to 1/4" , PP	
800-1160	Schottanschluss M16 1/4" auf 1/4"; PP	Bulkhead Union M16 1/4" to 1/4" , PP	
800-1162	Schlauch LLDPE 5/16"	Tube natur; 5/16" diameter; LLDPE	
800-1164	Einschraubwinkel DM 5/16" auf 3/8" NPTM Außengew.	Male Elbow DM 5/16" to 3/8" NPTM male	P002
800-1166	Winkelverbinder DM 5/16"	Elbow-Unit DM 5/16" ,PP	
800-1167	Einschraubanschluss DM1/4" auf 3/8" NPT AG.PP	Straight adaptor DM 1/4" to 3/8" NPTM male, PP	P001
800-1168	Einschraubwinkel DM 1/4" auf 1/8" NPTF Außengew.PP	Male Elbow DM 1/4" to 1/4" NPTF male, PP	
800-1169	Einschraubanschluss DM 5/16" auf 1/4" NPTM AG;PP	Straight adaptor DM 5/16" to 1/4" NPTM male,PP	
800-1170	Einschraubanschluss DM1/4" auf 1/4" NPT AG, PP	Straight adaptor DM 1/4" to 1/4" NPTM, male, PP	
800-1173	Einschraubanschluss 1/4" auf 1/4" Innengewinde	Straight adaptor DM 1/4" to 1/4" NPTF	
800-1174	Wasserhahnanschluss 1/4" x 3/4" NPTF	Female adapter NPTF Thread - 1/4" Tube - 3/4" NPTF-Thread	Einspeisung
800-1175	Schutzkappe UV-Strahler, für System 830-0566	Protection cap UV-lamp, for system 830-0566	
800-1176	Flachring groß für Tank Aquinity ² P10	Flat seal tank large Aquinity ² P10	
800-1177	Flachring klein für Tank Aquinity ² P10	Flat seal tank small Aquinity ² P10	
800-1179	Einschraubanschluss DM 5/16" auf 3/8" AG, PP	Straight adaptor DM 5/16" to 3/8" male	P002, RSV
800-1202	U Bend DM 1/4" , Acetal	U-Bend 1/4" PP	Fixierung Restriktoren

800-1206	Desinfektionskammer Astacus ² /Aquinity ²	Sanitization chamber Astacus ² /Aquinity ² ; 1/4"	
800-1208	Flachring für Tauchstrahler Aquinity ² , 6 Bohrunge	Flat seal submersible UV Aquinity ²	
800-1219	T-Verbinder DM 5/16"	T-Unit DM 5/16" , PP	
800-1220	Reduzier Winkelverbinder DM 5/16"/1/4"	Reducing elbow connector DM 5/16" to 1/4" , PP	
810-0029	Rohrschelle mit Bügel d 50	Pipe Clamp with Savety clip d50	
810-0080	Rohrschelle mit Bügel d 40	Pipe Clamp with Savety clip d40	
810-0082	Rohrschelle mit Bügel d 63	Pipe Clamp with Savety clip d63	
810-0187	Wandhalterung für MemTap, POM	Wall Mounting bracket MemTap; POM	
810-0462	Gehäuse Aquinity ²	Housing Aquinity ²	
810-0463	Gehäuse Astacus ²	Housing Astacus ²	
810-0464	Tank Aquinity ² , 70 l (Gehäuse)	Tank Aquinity ² , 70 l (case)	
810-0465	Tank Aquinity ² , 35 l (Gehäuse)	Tank Aquinity ² , 35 l (case)	
810-0471	Carrier Plate L	Carrier Plate L	
810-0476	Carrier Plate S	Carrier Plate S	
810-0479	Befestigungswinkel für Druckminderer 1/8"	Mounting bracket for pressure regulator 1/8"	
810-0482	Schirmblech	Shield plate	
810-0483	Block zur Aufnahme Leitfähigkeitssonde LF1, PVC	Block for conductivity cell LF1	Q001
810-0487	Tankauflage P10	Distance plae P10	
810-0489	Montageplatte A ²	Mounting plate A ²	
810-0490	Neodym Magnet 8 x 3,5 x 3 mm mit Senkbohrung	Neodym magnet 8 x 3,5 x 3 to A ² -Systeme	
810-0495	Bodenplatte Astacus ²	Base plate Astacus ²	
810-0512	Frontpanel 3, weiß. Kein Displayausschnitt	Front Panel 3, no cutout at all	
810-0513	Frontpanel 2, weiß Display- +Schlauchausschnitt	Front Panel 2, Material ABS + PMMA white; 3,2mm, display and tube cutout	
810-0514	Sidepanel L, Material ABS + PMMA weiß; 3,2mm	Sidepanel L, Material ABS + PMMA white; 3,2mm	
810-0515	Sidepanel S, Material ABS + PMMA white; 3,2mm	Sidepanel S, Material ABS + PMMA weiß; 3,2mm	
810-0525	Füße A ² -Systeme 30,5 x 25	Housing buffer	
810-0528	Stege für Frontpanel	front Panel 2, Material ABS + PMMA white; 3,2mm; RAL 7035	
810-0535	Halter für Controller Frontpanel V3	Holder for Controller Front Panel	
810-0546	Dispenser A ² , Auslöser	Dispenser A ² , release button	
810-0548	Dispenser A ² , Druckstift02	Dispenser A ² , pressure pin	
810-0549	Dispenser A ² , Hebel	Dispenser A ² , Lever	
810-0550	Dispenser A ² , Halbschale01	Dispenser A ² , Molding01	
810-0552	Dispenser A ² , Halterung	Dispenser A ² ; holder	
810-0553	Dispenser A ² , Halterung01	Dispenser A ² ; holder01	
810-0554	Neodym Magnet Ø 6mm x 3mm	Neodym magnet Ø 6mm x 3mm	
810-0555	Neodym Magnet 15 x 3,5 x 3 mm mit Senkbohrung	Neodym magnet 8 x 3,5 x 3 to A ² -Systeme	
810-0556	Wellschlauch für A ²	Bellow belt A ² , 1,8 m	
820-0010	Leitfähigkeitsmesszelle LFE c = 0,6	Conductivity cell with 1,00 m cable - Cell constant : c = 0,6	Q001
820-0019	Kabel	Cable	
820-0123	Vorschaltgerät für UV-Systeme Astacus / Aquintus	Ballast UV-system for Astacus / Aquintus systems	3X01;
820-0150	Kabelschuhe in Ringform, M4 Schrauben, 0,5- 1,5 ^2	Cable socket for M4 screws	
820-0172	Flachsteckverbinder, vollisoliert , 6,35 mm, rot	Connector for isolatet crimp connection 4,75 mm^2	
820-0235	Kühlung & Stromversorgung EDI 5-75	Cooling equipment & power supply EDI 5-75	CS002
820-0608	Druckschalter für Aquinity-System	Pressure switch 1/4" NPTF, switches between 0,5 - 3,1 bar	PSA-001

820-0723	Steckverbindung für Niveaugeber Aquinity ²	Connector level switch Aquinity ²	
820-0725	Steuerung Aquinity ² /Astacus ² mit 4,3" Display	CPU Aquinity ² /Astacus ² with 4,3" LCD display	CPU001
820-0729	Zapfpistolschalter für A ² -Systeme	Switch for dispenser A ² -systems	
820-0736	Reed-Schalter Aquinity ² /Astacus ²	Reed-switch Aquinity ² /Astacus ²	GS001
820-0737	Netzanschlussleitungen mit Schukostecker	AC power line with plug, length 2 m	
820-0739	PVC Steuerleitung 12x0,5	Control cable 12 x 0,5	
820-0778	3/2 Wegeventil, NC, 24 V DC, 6mm Schlauch push-in	3/2 way solenoid valve	SV010
820-0779	Wassermesser für Reinstwasser 1 - 4 l/min 6mm	Watermeter for ultra pure water 1- 4 l/min 6mm	FQ001
820-0791	Stabaufnahme UV-Tauchstrahler, Aquinity ² , 6 Bohr.	Bracket for submersible UV, Aquinity ²	
820-0816	Pumpe Typ KK 01 3 l/min	Booster pump type KK 01, 3 l/min	P001; P002;
820-0821	RC Kombination für Entstörung Magnetventil	RC combination for solenoid magnetic valve	
820-0827	Netzteil 24 V	Power supply 24 V	
820-0829	Reed-Schalter Astacus ² Rev.2	Reed switch Aquinity ² /Asatcus ² rev2	
820-0844	Netzteil 12 V	Power supply 12 V	
821-0001	Pumpen Anschlußkabel mit Stecker für A ² -Systeme	Connection cable with plug for A ² -Systems	
825-0059	Zugentlastung, Netzkabel	Power cord strain relief	
830-0048	Modulgehäuse für RO-Module RO/EDI bis 20l/h PP	Housing for RO-Module up to 20 l/h; 1/4" connections	
830-0073	Schwingmetallpuffer M6 x 18, d x h 20 x 15	Shock mount M6 x 18, d x h 20 x 15	
830-0192	Federbelastetes Rückschlagventil; Dichtung FKM O-Ring	Check valve PP 3/8" female thread; Sealing FKM O-ring	CV001
830-0195	Wanne PE zur Aufnahme eines Reinstwasser- Systems	Collecting tray for Ultrapure water system	
830-0286	Düse 0,85 mm POM für 6'er JG Fitting	nozzle 0,85 mm to fit 6 mm JG	RE001
830-0500	Druckminderer 2 - 3 bar, 1/4" Tube	Pressure regulator 2,5 bar, 1/4"Tube, PP	PRV001
830-0504	Magnetventil 24 VDC 1/4" NC	Solenoid valve 1/4" 24 V DC NC	SV001; SV003; SV005; SV006
830-0531	Magnetventil 24 VDC 1/4" NO	Solenoid valve 1/4" 24 V DC NO	SV002; SV004
830-0546	PureTap-Zapfpistole aus PVDF	PureTap dispense gun PVDF	
830-0565	Behälter Aquinity ² , 10 l	Reservoir Aquinity ² , 10 l	
830-0566	UV-Reaktor für Aquinity ² P10	UV-Reactor for Aquinity ² P10	
830-0569	UV - Tauchrohr aus Quarz für 921-0138	Dip tube for UV reactorchamber Art. 921-0138	
830-0570	UV - Tauchrohr aus Quarz für 921-0508	Dip tube for UV reactorchamber Art. 921-0508	
830-0571	UV - Stecker 4 pins	UV - sockets 4 pins	
830-0572	Rückschlagventil PP 3/8" Innengewinde, 1 bar	Check valve PP 3/8" female thread, 1 bar Sealing FKM O-ring	RV2
830-0573	Restriktor braun	Restrictor brown	
830-0574	Restriktor rot	Restrictor red	Re3
830-0575	Restriktor blau	Restrictor blue	
830-0576	Restriktor weiß	Restrictor white	RE001
830-0577	Gehäuse für A ² BI-Version, Steuerung	Housing for A ² BI-Version accepts control board and 4,3" display	
830-0578	Wandhalter für Gehäuse für A ² BI-Version	Wall bracket for housing for A ² BI-Version	
830-0581	Tank 35l A ² -Systeme UV	Tank 35l for A ² -systems UV	B001
830-0603	Tank 70l A ² -Systeme UV	Tank 70l for A ² -systems UV	B001
830-0613	UV-Reaktor für A ² -Systeme	UV-Reactor for A ² -Systems	UV001
830-0640	Behälter Aquinity ² , 10 l komplett	Reservoir Aquinity ² , 10 l, complete	
830-0642	Restriktor weiß, 25mm lang	Restrictor white, 25mm	
860-0043	Unterlegscheibe 6,4x30x3 PVC sw	Washer 6,4x30x3 PVC	

860-1361	USB 2.0-Stick 4GB	USB 2.0-Stick 4GB	
860-1642	Stecker DC 2,1x5,5mm	DC Connector	
860-1834	Diode	Diode	
860-1850	SD-Karte 2GB	SD-Card 2GB	
860-1922	Stecker 6 pol	Plug 6 pole	
860-1923	Steckerbuchse 6pol	Plug socket 6 pole	
860-1924	Lötkontakte Buchse	Plug socket 6 pole	
860-1996	USB Anschlusskabel, 50cm	USB cable 50 cm	
860-1997	Plastik Abdeckkappe USB	USB protection	
860-1998	Kaltgeräteverlängerungskabel	IEC cable	
860-1999	Schnurschalter AUS/EIN 16A	Cord switch 16A	optional
860-2000	Kaltgeräte Steckverbinder	IEC plug	
860-2001	Stromanschlusskabel 1.8m	Power cable 1,8m	
860-2002	Mikroschalter 250V/AC tastend	Microswitch 250V/AC	
900-1422	Manometer 0 - 10 bar, G 1/8" Anschluß rückseitig	Pressure gauge 0 -10 bar, 1/8 " center back connection, plastic	PI001
921-0138	UV-Strahler 185/254 nm für Reinstwassersysteme	UV-Lamp 185/254 nm ultrapure water systems	UV002
921-0225	EDI Zelle 10 l/h zweistufig, 1/4" Anschlüsse	EDI cell 10 l/h, 1/4" connections	E001
921-0372	Leitfähigkeitsmesszelle LFP c=0,01 TK ; 1/4"	Cell conductivity UPW-Systems LF2;LF3; LF4; Cell contant 0,01	Q002; Q003; Q004; TI002; TI003; TI004
921-0483	UV-Tauchstrahler für Aquinity ²	Submersible UV-Lamp for Aquinity ²	UV001
921-0496	Regelplatine Aquinity ² / EDI 5 - 55	Control board Aquinity ² / EDI 5 - 75	
921-0498	LF-Platine Aquinity ² / EDI 5 - 55	Conductivity board Aquinity ² / EDI 5 - 75	
921-0501	Zapfhahn für Aquinity ² P/E, weiß	Tap Valve for Permeat for Aquinity ² P/E	
921-0508	UV-Strahler 185/254 nm für Reinstwassersysteme	UV-Lamp 185/254 nm; UPW; flowrate 1,5 l/min for Aquinity P10	
921-0510	Dichtung für Zapfhahn für Aquinity ²	Washer for Tap Valve for Permeat for Aquinity ²	
921-0515	Vorschaltgerät für A ² -UV-System , 110 V	Ballast UV-system to fit Aquinity, 110 V	
921-0541	Hauptplatine A ² komplett bestückt, Rev.2	Main board A ² complete	
921-0542	Hauptplatine A ² teilbestückt, Rev.2	Main board A ² partly equipped	
921-0545	Dispenser A ²	Dispenser A ² , all wetted parts PVDF, sealing EPDM	V001

Versionsnummer

Datum	Version	Info	Bearbeitet von
2018.05.15	2.0	Initial Version	HaS