

**Qty. Description**

1 Installation kit 6/9 mm



Note! Product picture may differ from actual product

Product No.: [95730452](#)

Installation kit for easy installation of the dosing pump.

The kit includes:

- Non-return footvalve with strainer and weight
- Injection unit
- 6 m. discharge tubing
- 2 m. suction tubing
- 2 m. vent tubing

Technical:

Valve type: Without level switch

Materials:

Housing: PVC

Valve ball: Ceramic

Gasket: PTFE

Installation:

Inst. connect: G 1/2"

Tube size: 6/9 mm

Others:

Gross weight: 0.9 kg

Description	Value
<b>General information:</b>	
Product name:	Installation kit 6/9 mm
Product No:	<a href="#">95730452</a>
EAN number:	5710626576548
Price:	
<b>Technical:</b>	
Valve type:	Without level switch
<b>Materials:</b>	
Housing:	PVC
Valve ball:	Ceramic
Gasket:	PTFE
<b>Installation:</b>	
Inst. connect:	G 1/2"
Tube size:	6/9 mm
<b>Others:</b>	
Designed for:	DDA, DDC, DDE, DMX up to 30l/h
Gross weight:	0.9 kg

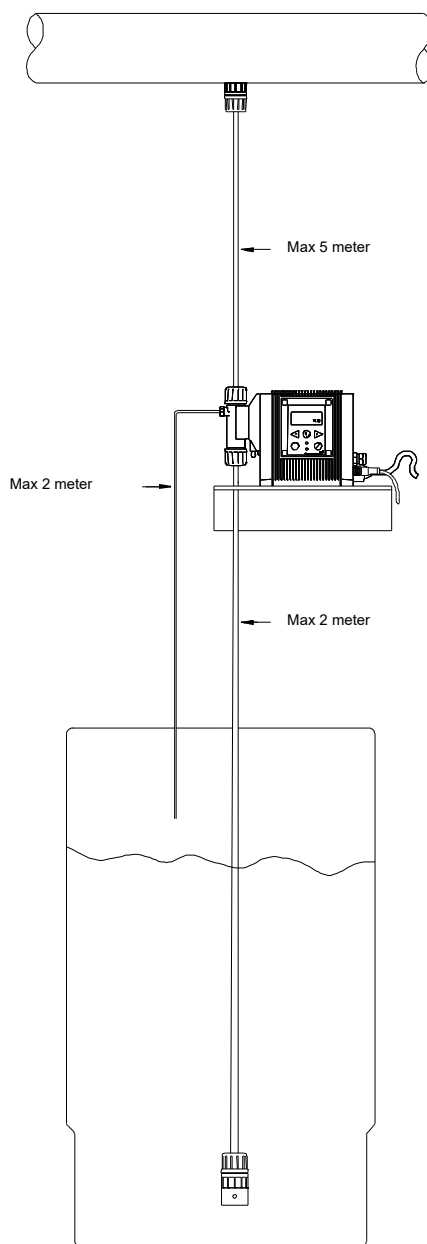

## 95730452 Installation kit 6/9 mm

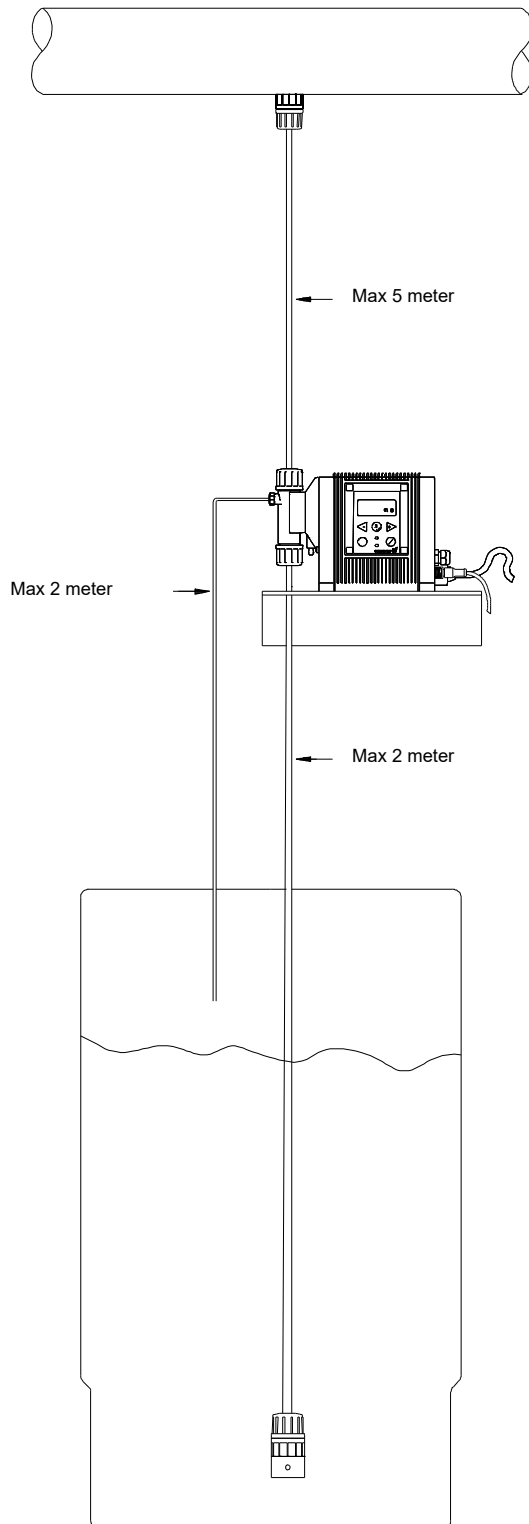

Note! All units are in [mm] unless others are stated.  
Disclaimer: This simplified dimensional drawing does not show all details.