

PROCESS		PART VERIFICATION SIGN OFF		
ORDER	PROCESS	NOTE	NAME	DATE
1	ASSEMBLE			

PartNo	DESCRIPTION	QTY.	UoM
4351	COLLAR	4	EA
9609	FIBER WASHER, 0.391 X 0.625 X 0.032	4	EA
EP6000.027	SPACER ROD	2	EA
EP6000.526A	ROCKER ARM ASSEMBLY	2	EA

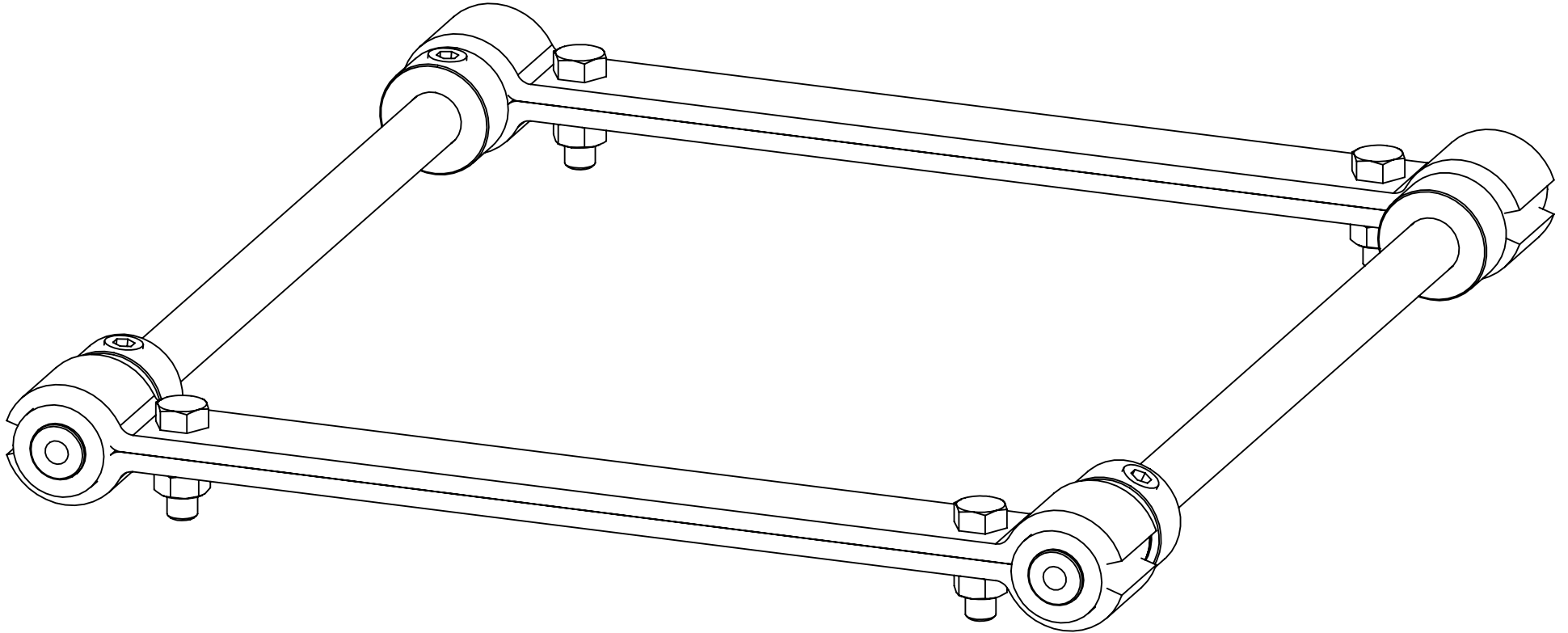

REVISIONS			
REV.	DESCRIPTION	DATE	APPROVED
A-01	ADDED TO THE VAULT	1/10/2020	CJ
A-02	UPDATED UOFM	6/8/2021	AM

DIMENSIONS ARE IN INCHES TOLERANCE UNLESS OTHERWISE SPECIFIED

FRACTION ±1/64	DECIMAL ±.1
ANGLE ±.5°	±.01
	±.005

3RD ANGLE PROJ

EBERBACH CORPORATION							
MATERIAL						STOCK NO.	
ROCKER ARM AND SPACER ROD ASSEMBLY						EP6000.565A	
1:1 SCALE	APPR	DEPT.	DATE	1.5LB WEIGHT	DRAWING STATUS	PRODUCTION	REV A-03
A		ENG.	01-10-20				

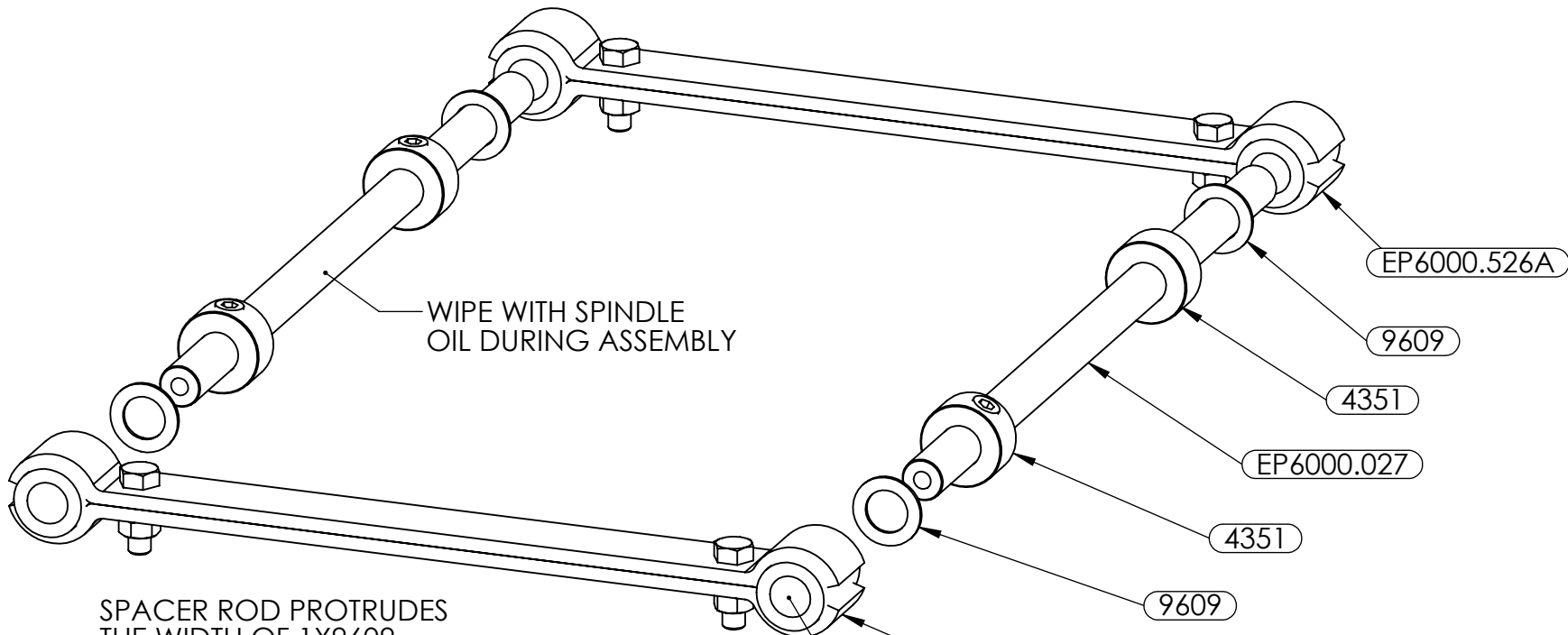

WIPE WITH SPINDLE OIL DURING ASSEMBLY

SPACER ROD PROTRUDES THE WIDTH OF 1X9609 BEYOND THE ROCKER ARM ASSEMBLY

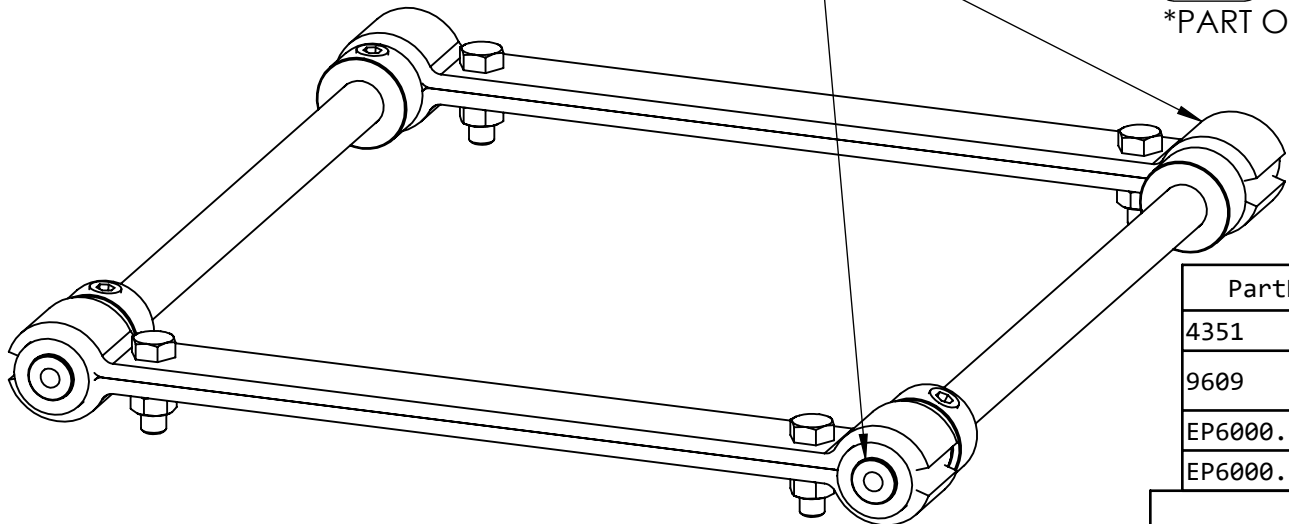

- EP6000.526A
- 9609
- 4351
- EP6000.027
- 4351
- 9609
- EP6000.526A
- 4173
*PART OF EP6000.526A

PartNo	DESCRIPTION	QTY.	UoM
4351	COLLAR	4	EA
9609	FIBER WASHER, 0.391 X 0.625 X 0.032	4	EA
EP6000.027	SPACER ROD	2	EA
EP6000.526A	ROCKER ARM ASSEMBLY	2	EA

EBERBACH CORPORATION

MATERIAL		-		STOCK NO.	
PART NAME			PART NO.		
ROCKER ARM AND SPACER ROD ASSEMBLY			EP6000.565A		
2:3	APPR	DEPT.	DATE	1.5LB	DRAWING STATUS
SCALE A		ENG.	01-10-20	WEIGHT	PRODUCTION
					REV A-03

DIMENSIONS ARE IN INCHES TOLERANCE UNLESS OTHERWISE SPECIFIED

FRACTION	DECIMAL
±1/64	.X ±.1
ANGLE	.XX ±.01
±.5°	.XXX ±.005

3RD ANGLE PROJ