

Antunes WATER

ANTUNES www.antuneswater.com 180 Kehoe Blvd., Carol Stream, Illinois 60188

TDS Monitor Instruction Kit (P/N 7010036)

⚠ CAUTION ⚠

To avoid possible personal injury and/or damage to the unit, all inspections, tests, and repair of electrical equipment should be performed by QUALIFIED SERVICE PERSONNEL. The unit MUST be completely shut down and unplugged before servicing.

TOOLS: Gloves

PARTS INCLUDED: Kit 7010036

- 1 TDS Monitor (P/N 4060580)
- 1 Instruction Sheet (P/N 1011622)

General

Total Dissolved Solids (TDS) are the total amount of inorganic elements, including minerals, salts or metals, dissolved in a given volume of water, other than the pure water molecules (H₂O) and suspended solids. TDS is expressed in parts per million (ppm). TDS affects everything that consumes, lives in or uses water. A lower TDS level in drinking water is preferred.

Instructions

NOTE: Never touch the sensor pins, as skin oils may adversely affect the TDS measurement. To clean the sensor pins, clean with rubbing alcohol and let air dry.

NOTE: If you notice the readings are off from what they should be, replace the batteries or re-calibrate.

To install the TDS Monitor to a water purification or filtration system, follow the steps below.

1. Ensure the white sensor is fully inserted into the T-fittings.
2. Orient the sensor pins so that they are perpendicular to the direction of the T. Both pins should be visible when looking through the fitting (Figure 3).

NOTE: Do not touch the sensor pins, as skin oils may adversely affect the TDS measurement.

3. Disconnect the water source.
4. Determine which water line to attach the Monitor to. Snip the water hose at a point between the tap and the filter to monitor the source water, OR at a point between the filter and a dispenser to monitor the product water.
5. Insert the two snipped ends of each water hose into the provided T-fitting.

NOTE: Ensure each end is fully inserted into the T-fitting.

6. The TDS Monitor should be attached as shown in Figure 3 above the RO system.
7. Reconnect the water source. Your monitor is now ready for use.

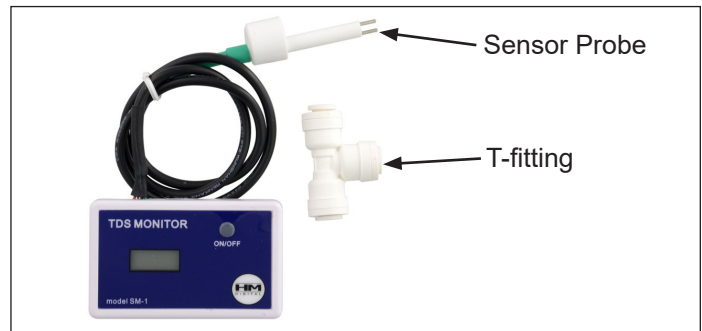

Figure 1. SM-1 TDS Monitor

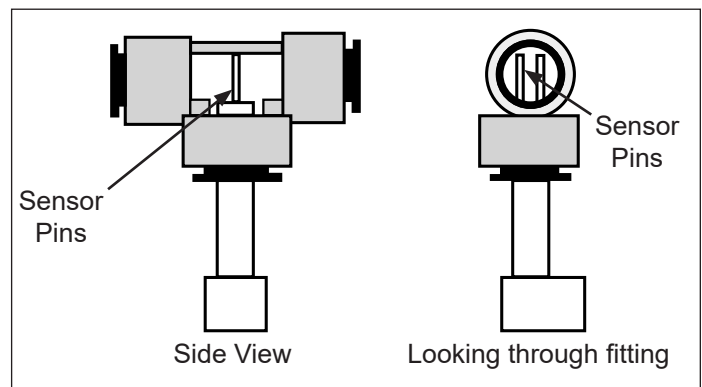

Figure 2. Sensor Pins in T-fitting

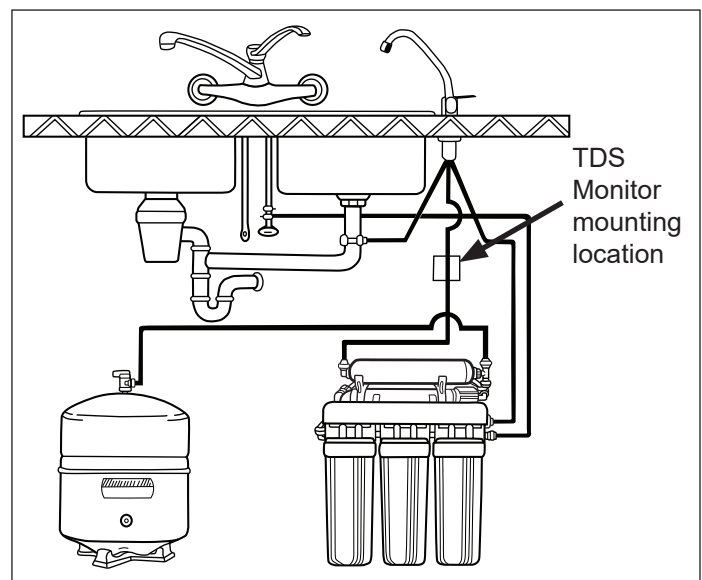

Figure 3. TDS Monitor Mounting Location

Antunes WATER

ANTUNES www.antuneswater.com 180 Kehoe Blvd., Carol Stream, Illinois 60188

TDS Monitor Instruction Kit (P/N 7010036)

Usage

1. Press the "ON/OFF" button.
2. The monitor will display the TDS level of the selected line.

NOTE: The displayed TDS will be most accurate after approximately 10 seconds.

3. Determining filter effectiveness depends on your particular system. For an RO system, compare the tap water TDS levels with the product water TDS.
4. Turn off the Monitor. It will automatically shut off after 10 minutes.

Changing Batteries

1. Unscrew the three metal screws on the rear of the unit and remove the back panel.

NOTE: Do not remove the orange plastic screw.

2. Remove the batteries.
3. Replace with new batteries (size 357-A). Ensure the polarity is correct.
4. Close the back panel and replace the screws.

Calibration

The monitor was factory calibrated to 342 ppm (NaCl). This level is suitable for most tap/water filtered water applications. However, you may need to re-calibrate based on your needs, as well as from time-to-time to ensure best results.

1. Purchase a calibration solution from your dealer that is correct for your needs.
2. Disconnect the T-Fitting from connected hoses.

NOTE: Do NOT remove the sensor from the T-fitting.

3. Ensure the orientation of the sensor to the fitting is correct (Figure 3).
4. Turn on the monitor and place the T-Fittings (with the sensor in it) into the calibration solution. You will get a reading.
5. If the reading on the monitor does not match the solution, adjust the reading up or down by gently turning the orange plastic screw on the rear of the monitor clockwise or counter-clockwise.
6. The monitor should read approximately 10% below the calibration solution. The monitor is designed for flowing water and this discrepancy will compensate for that.

NOTE: If you are calibrating with a flowing solution, ignore step 5.

7. Once the reading is correct, turn the monitor off and remove from the solution. Your monitor is now calibrated.